



**City of Phoenix
Water Services Department**

**DESIGN STANDARDS MANUAL FOR
WATER AND WASTEWATER SYSTEMS**

2026

**Water Services Department
200 West Washington Street
Phoenix, Arizona 85003-1697
Phone: (602) 495-5601
Fax: (602) 495-5461**

TABLE OF CONTENTS

TABLE OF CONTENTS	i
LIST OF FIGURES	v
LIST OF TABLES.....	v
I. INTRODUCTION	1
A. PURPOSE OF MANUAL	1
B. AUTHORITY	1
C. ORGANIZATION AND INTERPRETATION OF MANUAL	1
II. DEVELOPMENT COORDINATION BY DEPARTMENTS	1
A. WATER SERVICES DEPARTMENT (WSD).....	1
1. Role and Functions.....	1
B. PLANNING AND DEVELOPMENT DEPARTMENT (PDD).....	2
1. Role and Functions.....	2
III. GENERAL WATER AND SEWER DESIGN CRITERIA.....	3
A. GENERAL DESIGN CRITERIA/CONSIDERATIONS.....	3
1. Jurisdictional Agency Approvals.....	3
2. Standard Specifications and Details.....	3
3. Environmental and Cultural Regulatory Requirements	4
4. Community Notification and Involvement.....	5
5. Subsurface Investigations	5
B. LOCATION, ALIGNMENT, AND EASEMENT REQUIREMENTS FOR WATER AND SEWER MAINS 5	
1. Public Water and Sewer in the Public Right-of-Way	5
2. Public Water and Sewer within Private Accessways.....	6
3. Public Water and Sewer within all other Easements.....	8
4. Encroachments within an Easement	10
5. Encroachments Adjacent to Existing Water and Sewer Easements.....	10
6. Allowable Plants and Trees within an Easement	11
C. HORIZONTAL AND VERTICAL SEPARATION REQUIREMENTS.....	11
1. Separation Requirements from Water Supply System.....	14
2. Tree Separation Requirements	14
D. SUBMITTALS	17
1. Water and Sewer Master Plans, Reports, and Requirements	17
2. Design Reports.....	31
3. Checklists - Private Development and Capital Improvement Projects (CIP)	32
4. Construction Plans and Technical Specifications - CIP Projects/Projects with City Financial Participation	32
5. Record Drawings	33
6. Water Asset Management Information.....	33

E. WATER DEMAND AND SEWER DESIGN FLOWS	34
1. Water and Sewer Design Flows	34
2. Water Peak Flow	35
3. Sewer Peak Flow.....	35
F. WATER AND SEWER MAIN ABANDONMENT METHODS.....	35
G. WATER AND SEWER STUBS OR TAPS AHEAD OF PAVING.....	36
H. CROSS CONNECTIONS AND BACKFLOW PREVENTION	36
1. Cross Connection	36
2. Backflow Prevention	36
I. MAINTENANCE OF PLANT OPERATIONS (MOPO) PROCESS FOR CROSSING TRANSMISSION MAINS	36
1. Guidelines for Maintenance of Plant Operations (MOPO).....	36
IV. WATER DISTRIBUTION AND TRANSMISSION SYSTEMS	41
A. WATER SYSTEM OVERVIEW - PRESSURE ZONES.....	41
B. WATER MAIN DESIGN CRITERIA APPLICABLE TO BOTH DISTRIBUTION AND TRANSMISSION MAINS	42
1. Water Main Extensions.....	42
2. Water Requirements for City Defined Areas (Master Plan)	42
3. Water Main Classifications	43
4. Water Main Design	44
5. Fire Flow Demand	44
6. Hydraulic Requirements	44
7. Thrust Restraint for Distribution Mains	44
8. Corrosion Protection and Cathodic Protection	44
9. Shop Drawings	44
C. ADDITIONAL DESIGN CRITERIA ONLY APPLICABLE TO DISTRIBUTION MAINS	45
1. Acceptable Pipe Materials	45
2. Pipe Sizing for Distribution Mains.....	45
3. Distribution Main Cover	45
4. Line Valves	46
5. Service Connections (Taps) and Meters on Distribution Water Mains.....	46
6. Water Meters and Sizing Guidelines	49
D. ADDITIONAL DESIGN CRITERIA ONLY APPLICABLE TO TRANSMISSION MAINS	50
1. Acceptable Pipe Materials	50
2. Pipe Sizing.....	50
3. Transmission Main Cover.....	51
4. Line Valves	51
5. Restraint Systems	51
6. Corrosion Protection	52
7. Side Outlets	52
8. Bypass Assemblies	52
9. Air/Vacuum Valve Assemblies.....	52
10. Access Outlets for 42-inch Mains and Larger	52
11. Use of Fire Hydrants and Placement	52
12. Testing and Final Acceptance	53
13. Crossing of Transmission Mains	53
14. General Requirements for Working Around Prestressed Concrete Cylinder Pipe, Concrete Cylinder Pipe and Bar Wrapped Concrete Pipe.....	53

E. FIRE LINE SYSTEMS.....	55
1. Acceptable Pipe Materials.....	56
2. Design Requirements.....	56
F. IRRIGATION SYSTEMS.....	57
G. FIRE HYDRANT REQUIREMENTS.....	57
1. Location and Design Requirements.....	57
2. Coverage Requirements.....	58
3. Clearance Requirements.....	58
4. Specification Requirements.....	58
5. Maximum Fire Hydrant Spacing.....	58
6. Fire Hydrant Relocations.....	59
7. Private Fire Hydrants.....	59
V. WASTEWATER COLLECTION SYSTEM.....	59
A. GENERAL REQUIREMENTS.....	59
1. Arizona Aquifer Protection Permit Requirements.....	59
2. Sewer Main Extension.....	60
B. GRAVITY SANITARY SEWER MAINS.....	60
1. Acceptable Pipe Materials.....	60
2. Pipe Sizing.....	61
3. Slope.....	61
4. Cover.....	62
5. Sewer Main Connections at Manholes.....	62
6. Buoyancy.....	62
7. Depressed Sewers.....	63
C. MANHOLES.....	63
1. Manhole Locations.....	63
2. Manhole Spacing.....	63
3. Manhole Diameter.....	63
4. Metering Manholes.....	64
5. Clean Outs.....	64
6. Manhole Stub Outs and Knock Outs.....	64
7. Drop Sewer Connections.....	64
8. Water Tightness.....	64
9. Corrosion Protection for Manholes.....	64
10. Junction Structures.....	64
D. SERVICE CONNECTIONS.....	65
1. Service Connection Installation Requirements.....	65
2. Type of Developments Allowed to Share a Sewer Service Connection.....	66
3. Service Connection Sizes.....	66
4. Service Connections in Manholes.....	66
E. WASTEWATER LIFT STATIONS AND FORCE MAINS.....	67
F. INDUSTRIAL AND COMMERCIAL DISCHARGE PRETREATMENT REQUIREMENTS.....	67
1. Code Requirements.....	67
2. Industrial Facilities.....	67
3. Sampling Facility Requirements.....	68
4. Flow Monitoring Facility Requirements.....	69
5. Pretreatment By-pass Requests.....	69
6. Commercial Facilities.....	69

G. SEPTIC SYSTEMS WITHIN THE CITY OF PHOENIX	72
1. City Ordinances Which Apply to Septic Systems.....	72
2. When NEW Septic Systems May Be Allowed	72
3. When Existing Septic Systems May Remain In Use	73
VI. APPEAL PROCESS FOR WATER/SEWER REQUIREMENTS	73
A. PURPOSE OF TECHNICAL APPEALS.....	73
B. DEVELOPER AND HOMEOWNER APPEALS	74
D. SUBSEQUENT TECHNICAL APPEAL PROCESS.....	74
E. WSD DIRECTOR’S REPRESENTATIVE INTERPRETATION OF CITY CODE PROCESS	75
F. UTILITIES CROSSING PROPERTY LINES APPEALS	75
G. OTHER APPEALS.....	75
APPENDIX A - Website Links.....	A-1
APPENDIX B - Definitions and Terms	B-1
APPENDIX C - Acronyms	C-1
APPENDIX D - Requirements for Corrosion Protection Design Standards Development Report for Large Diameter Ductile Iron, Steel, CCP, and RCP Water Transmission Pipelines	D-1
APPENDIX E – Procedure for Water Tapping Services into Reinforced Concrete Pipe (RCP) and Concrete Cylinder Pipe (CCP)	E-1
APPENDIX F - Construction Specification for Ductile Iron Sanitary Sewer Lines	F-1
APPENDIX G – MOPO Examples	G-1

LIST OF FIGURES

Figure 1. Standard Private Accessway.....	6
Figure 2. SFI Accessway.....	7
Figure 3. Plant Root Barrier Detail.....	17
Figure 4. MOPO Requirements for Excavation Near a Water Transmission Main... 38	
Figure 5. MOPO Requirements for Excavation Near a Sewer Force Main or Sewer Main.....	40
Figure 6. Typical Major Water Pressure Zone Configuration (rounded to the nearest 10 psi).....	42
Figure 7. Boundary Map for Downtown Core Area.....	43
Figure 8. Excavations Near PCCP.....	54
Figure 9. Conceptual Detail for Structural Support of PCCP.....	55
Figure 10. Detail for ESD/IPP Laser Manhole Monitoring Compliance Sample Point Detail.....	71
Figure 11. Detail for ESD/IPP Standard Compliance Sampling Point.....	71
Figure 12. Typical Gravity/Solids Interceptor.....	72

LIST OF TABLES

Table 1. Minimum Easement Widths for Water Mains with 8 feet or less of Cover... 8	
Table 2. Minimum Easement / Clearance for Appurtenances.....	9
Table 3. Minimum Easements for Sewer Mains.....	9
Table 4. Water / Sewer Horizontal Separation Requirements.....	12
Table 5. Water / Sewer Vertical Separation Requirements.....	13
Table 6. List of Acceptable Plants and Trees.....	14
Table 7. Example Land Use Plan Data.....	19
Table 8. Example Projected Population Table [for Phase Number _____].....	20
Table 9. Example Water Demand Calculations [for Phase Number _____]... 20	
Table 10. Example Land Use Plan Data.....	26
Table 11. Example Projected Population Table ⁽¹⁾ [for Phase Number _____].....	26
Table 12. Example Wastewater Flow Calculations ⁽¹⁾ [for Phase Number _____]. 27	
Table 13. Sample WAM Information.....	33
Table 14. Water and Wastewater Design Flows.....	34
Table 15. Minimum Water Main Sizing within COP Grid Distribution System.....	45
Table 16. Valve Spacing.....	46
Table 17. Domestic Meter Sizes.....	47
Table 18. Water Meters and Sizing Guidelines.....	50
Table 19. Allowable Velocity and Headlosses.....	51

Table 20. Line Valve Spacing.....	51
Table 21. Fire Hydrant Spacing.....	58
Table 22. Design Slopes.....	61
Table 23. Connections to Existing Sewer System (applies to new connections only).	62
Table 24. Maximum Manhole Spacing.....	63
Table 25. Minimum Manhole Diameters.....	64
Table 26. Service Connection Sizes.....	66
Table 27. Industries Requiring Compliance Sampling and Monitoring Locations... 	68
Table 28. Commercial Facilities Requiring Interceptors.....	70

I. INTRODUCTION

A. PURPOSE OF MANUAL

The purpose of this manual is to provide guidelines and minimum design criteria for the design of water and wastewater piping systems for the City of Phoenix (COP), either as part of Capital Improvement Program (CIP), or as private development projects that will construct and dedicate the systems to the City. The manual applies to existing systems being expanded, modified, upgraded, and rehabilitated, as well as to the construction of new mains. The manual is not intended to be used as a construction specification. All units of measurement used in this manual are United States standard measures unless otherwise noted. The Water Services Department (WSD) has implemented a separate addendum to provide design standards for projects along existing and future METRO light rail corridors. In addition, WSD has design manuals available for other facilities (booster stations, lift stations, reservoirs, and pressure reducing valve stations). These additional design guidelines are located on our website. See **Appendix A** for reference.

B. AUTHORITY

The design standards set forth in this manual are adopted pursuant to the authority granted in ARS 9-276 and 48-572 and Sections 37-2, 37-3, 37-17, 28-3, and 28-16 of the Phoenix City Code (PCC).

C. ORGANIZATION AND INTERPRETATION OF MANUAL

This manual is composed of written engineering standards, references to established standards of other organizations and agencies, and standard details of WSD. The Director of WSD, whose interpretation shall be binding and controlling in its application, shall make the interpretation of any section or of differences between sections. NOTE: Any deviations from the standards in this manual shall require a Technical Appeal to the WSD Director's Representative. This appeal application is submitted to the Planning and Development Department (PDD) through the standard Technical Appeal process. The Technical Appeals Procedure (P-107) can be found in WSD's website. For website link, refer to **Appendix A**, page A-2.

II. DEVELOPMENT COORDINATION BY DEPARTMENTS

WSD and PDD are the two City departments that review and approve public water and sewer infrastructure plans. The following department descriptions provide an overview of the jurisdictional areas and services provided by each department.

A. WATER SERVICES DEPARTMENT (WSD)

WSD is empowered by the Phoenix City Code to ensure the proper administration and operation of the water and wastewater works of the City. WSD operates under a Deputy City Manager who reports to the Assistant City Manager. The Water Services Director is the general executive officer of WSD. The Director is in charge of all personnel and the entire operation, equipment and facilities of WSD. The Director also has general supervision over all charges for water and wastewater services, departmental policies, agreements, new connections, repairs, other operational works, and for all charges not explicitly provided for in the City Code, subject to approval of the City Manager.

1. Role and Functions

WSD is responsible for technical review, approval, inspection and coordination of all public infrastructure projects, which include the following:

- a. Booster pump stations¹

- b. Pressure reducing facilities¹
- c. Storage facilities¹
- d. Well sites
- e. Water transmission mains (16-inch diameter and larger)
- f. Sewer mains (15-inch diameter and larger)
- g. Sewer Connection Details (S-512, S-512D, S511) in sewer mains larger than 15 inches
- h. Sewage lift stations¹
- i. Water and sewer master plans
- j. Water and wastewater treatment facilities¹
- k. CIP projects for Aviation and Streets Departments
- l. Joint venture agency projects through Intergovernmental Agreement
- m. All plans outside city limits within the City's service area including:²
 - 1. All water mains
 - 2. All sewer mains
 - 3. Fire lines
 - 4. Fire hydrants
 - 5. Water and sewer main abandonments
 - 6. Water main vertical realignments
 - 7. S-512, S-512D, S-511 Details

¹ WSD and PDD will jointly review these types of plans. WSD will review a conceptual design plan prior to the review by PDD. PDD is responsible for the civil site review and the building code review. WSD is responsible for the review of the guide specifications and standards as per the Water Remote Facilities Design Guidance Manual and the Wastewater Lift Station Design Manual. These manuals can be found in WSD's website. For website link refer to **Appendix A**, page A-2.

² If any portion of a project falls outside the Phoenix city limits, the developer must also include the approval and processes of the prevailing jurisdictional agency.

B. PLANNING AND DEVELOPMENT DEPARTMENT (PDD)

1. Role and Functions

PDD is responsible for technical review, approval, inspection, and coordination of all public infrastructure projects, which include the following:

- a. Water mains smaller than 16 inches in diameter
- b. Sewer mains smaller than 15 inches in diameter
- c. Fire lines
- d. Fire hydrants
- e. Water and sewer main abandonments
- f. Water main vertical realignments
- g. Sewer Connection Details (S-512, S-512D, S-511) in sewer mains 15 inches and smaller
- h. Any other 8 ½ x 11 standard detail plans

Contact PDD for more detailed information describing the development review process. The general phone number is 602-262-7811 or refer to PDD's website. For website link refer to **Appendix A**, page A-3.

III. GENERAL WATER AND SEWER DESIGN CRITERIA

A. GENERAL DESIGN CRITERIA/CONSIDERATIONS

1. Jurisdictional Agency Approvals

All appropriate agency levels affected within the Federal, State, County, and City involvement need to be contacted for their individual design requirements. Additionally, utility owners and railroad companies may have additional requirements and permitting processes that all developments need to follow when working near or crossing their facilities. This includes the need to obtain a construction license or a "no conflict" document, which will be required at the time of purchasing a water or sewer service from utility owners like SRP.

These requirements will need to be addressed in a top-down priority to avoid approval conflicts. This includes areas that are outside the city limits but served by the COP water and sewer system.

NOTE: Any and all more stringent requirements by Federal, State, County or local codes or ordinances shall take precedence.

2. Standard Specifications and Details

The standard specifications and standard details relating to water and wastewater systems that are referenced in this manual include the following:

- a. Uniform Standard Details and Specifications for Public Works Construction sponsored and distributed by the Maricopa Association of Governments (MAG). These details and specifications are herein referred to as MAG Details and MAG Specifications. These details and specifications are revised and updated periodically and are available electronically through the MAG office in Phoenix. For website link refer to **Appendix A**, page A-2, Specifications and Details, Maricopa Association of Governments Specifications and Details.
- b. City of Phoenix Supplements to the Maricopa Association of Governments Uniform Standard Specifications and Details for Public Works Construction. These specifications and details are herein referred to as COP Supplement Specifications or COP Supplement Details. These specifications and details are updated and revised periodically and are available electronically through the Street Transportation Department (STR). For website link refer to **Appendix A**, page A-2, Specifications and Details, City of Phoenix Supplements.
- c. Uniform Standard Details developed by the City of Phoenix Water Services Department are herein referred to as WSD Details.
- d. Water Services Department's Design Manuals, Checklists, Engineering Details, Policies and Procedures.

DESIGN MANUALS

- Design Standards Manual for Water and Wastewater Systems
- Addendum for Water and Sewer in Light Rail Corridors
- Wastewater Lift Station Design Manual
- Water Remote Facilities Design Guidance Manual
- Wastewater Lift Station Design Manual
- Requirements for Corrosion Protection Design Standards

- Checklist Requirements for Water and Sewer Plans
- Water and Wastewater Engineering Details
- Water and Wastewater Engineering Policies

SPECIFICATIONS AND DETAILS

- Maricopa County Environmental Services Department (MCESD) – Environmental Forms
- Salt River Project – Water Construction and Engineering Standards

ARIZONA DEPARTMENT OF ENVIRONMENTAL QUALITY (ADEQ)

- Arizona Administrative Code Title 18, Water Pollution Control
- Arizona Pollutant Discharge Elimination System (**AZPDES**) Permit

CITY OF PHOENIX WATER AND SEWER CHAPTER CODES

- Chapter 19A: Residential Development Occupational Fee – Sewer
- Chapter 19B: Commercial and Industrial Development Occupational Fee – Sewer
- Chapter 19C: Residential Development Occupational Fee – Water
- Chapter 19D: Commercial and Industrial Development Occupational Fee – Water
- Chapter 28: Sewer
- Chapter 30: Water Resources Acquisition Fee
- Chapter 37: Water

PLANNING AND DEVELOPMENT DEPARTMENT WEBSITE

- A to Z Topics – All topics relating to development
- Civil Topics – Applications, checklists, forms, etc.
- Fee Schedule
- Boundary Map for City’s Infill Development District

STREET TRANSPORTATION DEPARTMENT WEBSITE

- City of Phoenix Standard Utility Locations Manual

3. Environmental and Cultural Regulatory Requirements

This section is not intended to be all encompassing; but is provided as an overview of environmental and cultural requirements and typical agency involvement. A thorough consideration of the environmental and cultural impact of the project at the project location or along the project route shall be evaluated to identify environmental and cultural requirements. Private developers shall be responsible for regulatory compliance and for obtaining the required permits for their projects.

The Environmental Assessment Declaration form can be obtained from PDD’s website link. Refer to **Appendix A**, page A-3, Planning and Development Department, A to Z Topics, Environmental Assessment Declaration Form.

Whenever a project impacts Waters of the United States, a Clean Water Act Section 404 permit will be required by the U.S. Army Corps of Engineers (Corps). Compliance is also required with the Arizona Pollutant Discharge Elimination System (AzPDES) general permit for storm water discharges from construction sites, and with the De Minimis General Permit (DMGP) for certain types of non-stormwater discharges. For more information visit ADEQ's website. Refer to **Appendix A**, page A-2, Arizona Department of Environmental Quality, AzPDES.

Projects shall not adversely impact threatened or endangered species or their habitat and shall comply with the Federal Endangered Species Act. To address any biological requirements, an assessment report of the project may be required by the U.S. Fish and Wildlife Service and the Arizona Game and Fish Department.

No project shall adversely impact historic or prehistoric properties. Projects shall comply with the National Historic Preservation Act, the City's Archaeological policy, the Arizona Antiquities Act, and the State Historic Preservation Act. As part of the cultural resource's consideration, the City of Phoenix Archaeologist and the City of Phoenix Historical Preservation Office may be contacted for additional information and direction.

4. Community Notification and Involvement

The City has made a commitment to early citizen notification and involvement. The goal of identifying neighborhood concerns has a high priority. Communication through printed notice, a public information phone number and public presentations could be a necessary element in construction plan approval.

5. Subsurface Investigations

A comprehensive investigation of all nearby existing and proposed utilities will need to be conducted in order to avoid possible conflicts. In areas with a large number of utilities, including the Downtown Core Area, additional quality levels of Subsurface Utility Engineering need to be considered to avoid issues arising during construction.

When requested by WSD, a geotechnical engineer shall perform a soil investigation to determine the soil bearing capacity, soil backfill suitability, presence of groundwater or bedrock, corrosion potential and other conditions, which may affect the construction of the water or sewer main. Test holes shall be located at a maximum spacing of not more than 1,000-feet and at railroad, highway, and canal crossings.

B. LOCATION, ALIGNMENT, AND EASEMENT REQUIREMENTS FOR WATER AND SEWER MAINS

A route study or alignment report shall be completed to assure a functional hydraulic gradient/grade as well as continuity of an accessible right-of-way (ROW) and/or easement corridor.

The WSD requires safe and quick access to all City water and sewer mains at all times in order to repair main breaks, install taps, and perform preventive maintenance. For this reason, City of Phoenix water and sewer mains shall be constructed within the public ROW as discussed below. Water and sewer mains that are not installed in the ROW may only be permitted within a dedicated water or sewer easement. The water and sewer easements are discussed later in this chapter.

1. Public Water and Sewer in the Public Right-of-Way

The location and alignment of all water and sewer mains in the ROW shall be per the latest edition of Standard Utility Locations Manual for the City of Phoenix. Design engineers can obtain a copy through the Street Transportation Department. The standard utility locations are presented with the realization that every case will not be covered, and there may be instances where the standards cannot be applied. Refer to the website link in **Appendix A**, page A-3, Street Transportation Department, *City of Phoenix Standard Utility Locations*.

When the developer is only required to dedicate ROW for half street improvements, the WSD will allow water and sewer main extensions to be constructed in non-standard locations within the half street. However, a technical appeal must be filed with WSD to approve the location of the proposed main(s) on a case-by-case basis.

2. Public Water and Sewer within Private Accessways

The location and alignment of water and sewer mains in private accessways can only be used for single-family residential developments with individual lots. A private accessway will only be permitted if it complies with options a. or b. as follows:

- a. Standard Private Accessway dedicated as shown in **Figure 1**, *Standard Private Accessway*.

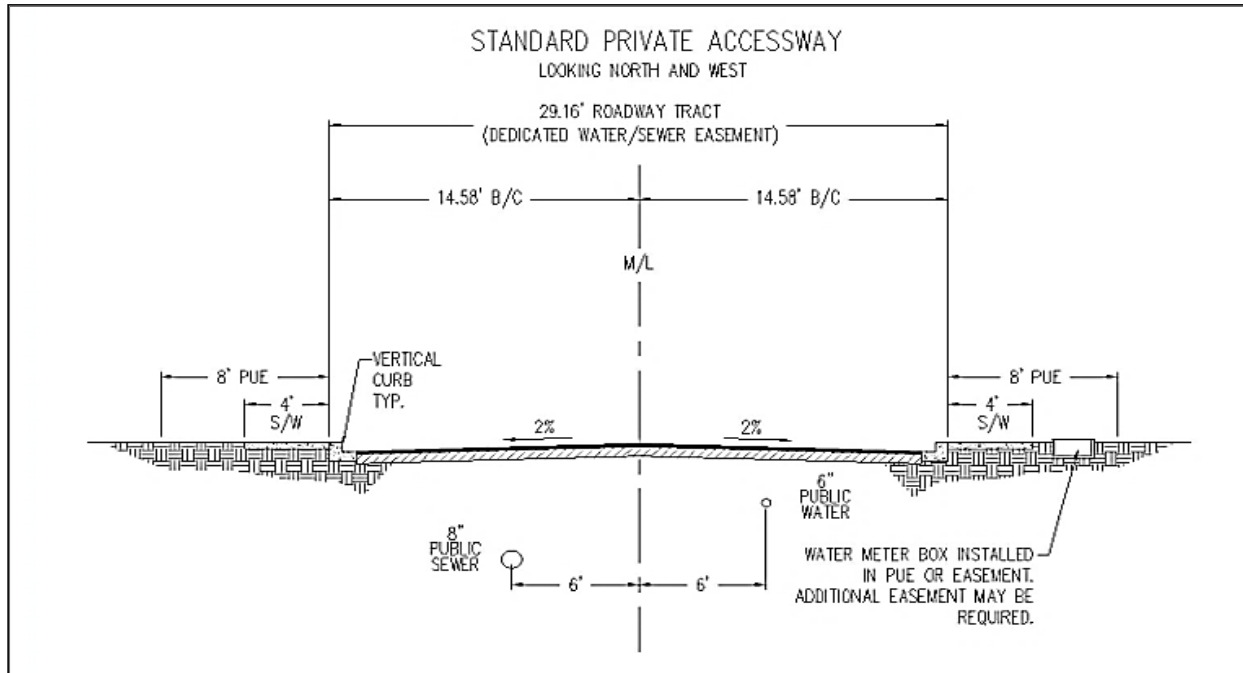

Figure 1. Standard Private Accessway.

- b. The development must meet the definition of Single-Family Infill (SFI) subdivisions as defined by the Phoenix Zoning Ordinance Section 202, and dedicate SFI private access way as shown in Figure 2, SFI Option Private Access Way.

The following additional requirements apply:

- a. Private Accessways shall be constructed per COP Supplement Detail P-1020-1 and P-1020-2 per Figures 1 or 2, whichever applies per options a. or b. mentioned above.
- b. The entire Private Accessway shall be dedicated as an exclusive public water/sewer easement within a dedicated tract to be owned and maintained by the Homeowner's Association (HOA).
- c. Gated communities shall provide dedicated access codes or keys to the Water Services Department. This access would be similar to the access granted to the Fire Department.
- d. Where possible, the private streets under which the City water and sewer mains are located shall have a minimum of two ingress/egress points. If dead-end streets must be used, the homebuilder shall make full disclosure to buyers that access in or out of their property may be denied without prior notice in order to perform maintenance or repair of the City water mains, sewer mains, or water meters.

- e. If the subdivision requires a private storm drain within the development, it shall be approved during the preliminary site plan review process. The water and sewer mains shall be required to maintain a minimum of 6 feet of horizontal separation from the storm drain measured from outside of pipe to outside of pipe. The instance where private storm drains are required, the water and sewer mains shall be installed 9 feet from the monument line. This alignment shall be required for the entire length of the street that contains the storm drain; for all streets not containing storm drains, water and sewer mains shall be installed at the required standard 6 feet from the monument line.

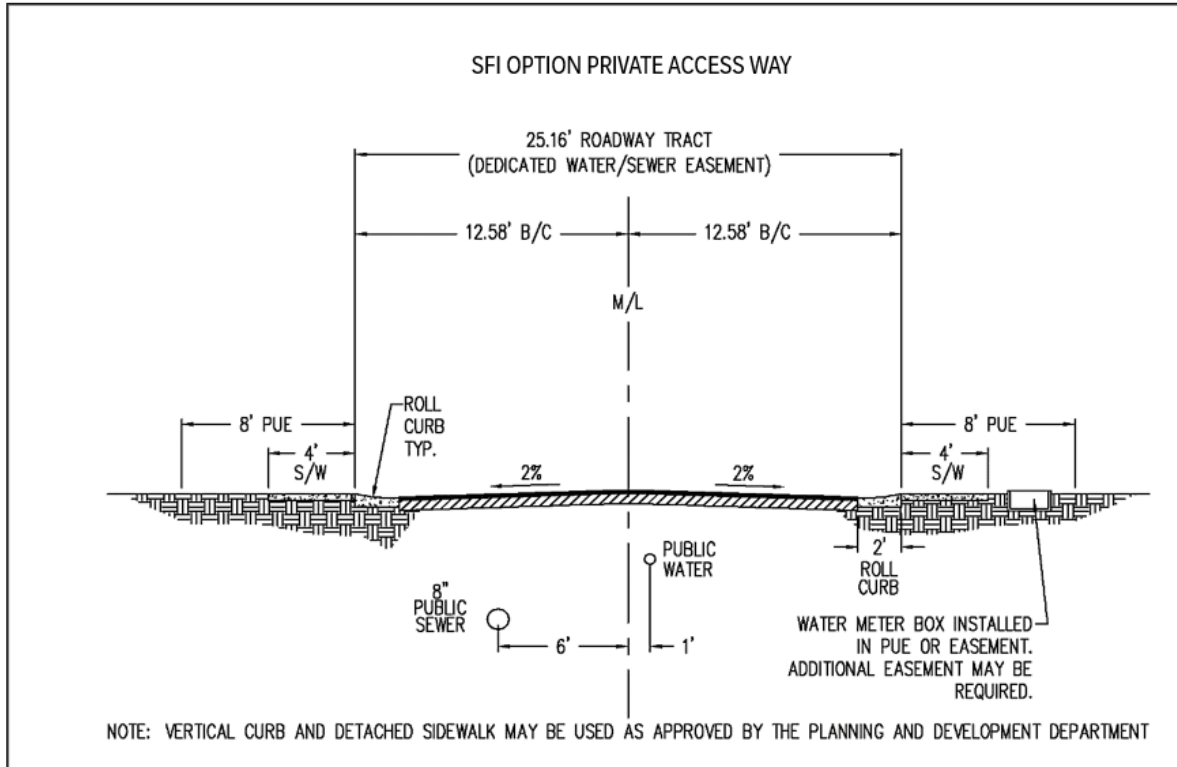

Figure 2. SFI Accessway.

Additional Items **f - h**, apply to SFI Option **ONLY**:

- f. The minimum clear distance between any portion of the building face, including overhangs but excluding roof eaves, across the private street is 32 feet. Roof eaves that project into the 32-foot clear distance shall have a minimum of 18 feet of vertical distance from the finished floor elevation and each shall have a maximum of 18 inches of horizontal projection into the 32-foot clear distance on each side.
- g. All water main joints, valves, fittings and bends in a reduced easement shall be restrained per MAG Standard Details 303-1 & 2 and City of Phoenix Supplement Specifications Section 750.3.
- h. In the event that water main distance to the edge of the building foundations is 15 feet or less, the foundations shall be designed to prevent a building collapse or damage by limiting the deflection of the foundation due to loss of soil beneath the foundation in the event of a water main break. A certified statement from a structural engineer registered in Arizona is required. At a minimum, one of the following alternatives shall be met:
 1. **Option 1 - Cutoff Wall:** Construct a cutoff wall around the perimeter foundation adjacent to the street. The cutoff wall shall be a minimum of 2 feet deep and 1 foot thick and shall be constructed of 500-psi (minimum) concrete. The cutoff wall is to be constructed along the front edge of the foundation and must wrap at least 10 feet along the structure's sides. The cutoff wall is intended to provide a barrier between the building and the water main in the event of a water or force main break, and thus reducing the potential damage to the

building. The cutoff wall shall be designed by the developer's structural engineer, based on the above requirements or soils report, whichever is more stringent.

2. **Option 2 - Reinforced Slab:** Design the foundation strong enough to resist sagging in the event of ground loss beneath the foundation caused by scouring from a water or force main break. The foundation along the side of the home facing the street shall be designed with a 5-foot cantilever. The allowable deflection at the free edge of the cantilever shall be calculated as $L/360$ for slabs with stucco, $L/240$ for other brittle finishes and $L/480$ for brick veneer exteriors. The distance L used in the equation should be taken as twice the length of the cantilever. Therefore, for a slab supporting stucco exterior housing, the post-tensioning and slab thickness shall be designed as required to limit the deflection at the free end of the overhang to be less than 0.33 inches of differential deflection between the edge of slab and 10 feet inward. The stresses in the slab and overhang shall be kept at or below the City's building code requirements. All other applicable design cases including center edge lift, etc., shall also be evaluated using the appropriate stress and deflection criteria.

3. Public Water and Sewer within all other Easements

- a. General - Easements will only be considered in the following cases:
 1. The project route falls in a future ROW alignment.
 2. A short segment of water or sewer main that is not technically feasible to design in the ROW and the proposed alignment results in a more efficient operation of the water or wastewater system.
 3. As approved by WSD through the Technical Appeal process.
 4. For projects requiring the installation of public water or sewer infrastructure within a property owned by the City of Phoenix, a temporary right-of-entry access agreement must be executed prior to construction. Contact WSD to initiate the process during the design review.
- b. Minimum Easement Widths for Water Mains:

The minimum widths for water mains with 8 feet of cover or less shall be as shown in **Table 1**, *Minimum Easement Widths for Water Mains*.

Table 1. Minimum Easement Widths for Water Mains with 8 feet or less of Cover.

Main Diameter (inches)	Minimum Easement Width (feet)
12 and Less	25
16 to 30	50
Greater than 30	80

- c. For water mains with greater than 8 feet of cover, easement width may be increased on a case-by-case basis to reflect the required construction and maintenance activities.
- d. All appurtenances shall have a contiguous easement/clearance as shown in **Table 2**, *Minimum Easement/Clearance for Appurtenances*. Additional easement may be required.
- e. The minimum widths for sewer mains shall be as shown in **Table 3**, *Minimum Easement Widths for Sewer Mains*.

Table 2. Minimum Easement / Clearance for Appurtenances.

Appurtenances	Minimum Clearance / Easement
Air Relief	3 feet on all sides of the metal cage
Fire Hydrant	6 feet clear from outside of hydrant
Meters 2 inches and smaller	3 feet on all sides
Meters 3 inches and larger	3 feet on all sides of meter vault
Miscellaneous	6 feet on all sides

Table 3. Minimum Easements for Sewer Mains.

Main Diameter (inches)	Cover Depth (feet)	Minimum Easement Width (feet)
15 and Less	< 10	35
15 and Less	10 - 15	40
15 and Less	> 16 - 20	45
15 and Less	> 20	50
16 to 30	< 10	40
16 to 30	10 - 20	50
16 to 30	> 20	60
Greater than 30	Any	80

f. Additional Easement and Main Requirements:

1. Easement Dedication - Easements shall be located in tracts. It shall be dedicated and restricted for COP water and sewer mains only. Public utility easements (PUEs) are not acceptable. Back lot or side lot easements will not be allowed. All other easements will be reviewed on a case-by-case basis by WSD.
2. Main Alignment - a single water or sewer main shall be centered within the easement. For multiple mains, water and/or sewer mains must maintain minimum separation requirements centered within the easement.
3. If parallel City water or sewer mains are to be located in the same easement, the adjusted minimum easement width for the overlapping easements shall be the greater of the water or the sewer easement width, based on size and depth of the mains, plus an additional 7 feet.
4. Easements within retention/detention basins are not allowed.
5. At wash crossings, pipe appurtenances (e.g., manholes, fire hydrants or valves) are not allowed within the 100-year flood plain limits.
6. Re-developed parcels having existing easements that do not meet the current minimum easement width requirements, will be reviewed on a case-by-case basis by WSD.

7. All Weather Access Road - water and sewer easements not in a Private Accessway require an all-weather access road. This allows the mains and all pipe appurtenances (e.g., valves, fire hydrants, and manholes) to be accessible at all times. The following requirements shall apply:
 - The access road shall have a minimum width of 12 feet and shall be paved or constructed of a minimum of 6-inch-thick stabilized decomposed granite or other material as approved by WSD.
 - The road shall be located 3 feet to the side of the main(s) or as approved by WSD through the Technical Appeal process.
 - Each end of the access road shall connect to a public street, private accessway or a turnaround easement.
 - The maintenance of access roads within water and sewer easements is the responsibility of the property owner or homeowner's association and shall be indicated as such in the Conditions, Covenants, and Restrictions (CC&Rs). A copy of the CC&Rs providing evidence of this maintenance responsibility by the homeowner's association or other ownership group shall be submitted to PDD for verification.
8. The easement shall be graded to convey drainage away from any existing vaults or assemblies within the easement to prevent flooding. Easement shall be accessible for maintenance and free of any trees, block walls, fences, and grades.

4. Encroachments within an Easement

Water and sewer easements shall be free of all obstructions and shall at all times be accessible to City service equipment. No buildings, sport courts, swimming pools, fences, shade structures, appurtenances, concrete pads, nor permanent structures of any kind shall be constructed upon, over or under any water or sewer easements.

No landscaping shall be placed within an easement that will render the easement inaccessible by equipment. WSD has the right to remove any obstruction without notice to the property owner, and all related costs shall be the property owner's responsibility. The maintenance of all landscaping in easements is the responsibility of the property owner or homeowner's association thereof and shall be indicated as such in the Conditions, Covenants, and Restrictions (CC&Rs). A copy of the CC&Rs providing evidence of this maintenance responsibility by the homeowner's association or other ownership group shall be submitted to the City of Phoenix, PDD for verification.

In general, all encroachments into water or/and sewer easements require approval from WSD, through technical appeal process.

5. Encroachments Adjacent to Existing Water and Sewer Easements

No buildings or permanent structures will be allowed to encroach on a water or sewer easement.

Regardless of the easement width, buildings shall have a sufficient setback from the water or sewer pipe such that buildings, building foundations or building slabs will not be undermined or damaged by a water or sewer main break or subsequent repair.

If the water or sewer easement does not meet the minimum width requirements as shown in **Table 1**, *Minimum Easement Widths for Water Mains*, and **Table 3**, *Minimum Easement Widths for Sewer Mains*, then clearances shall be as follows:

Sewer

Buildings, building slabs or structures proposed outside of the easement but parallel to a sewer main at a horizontal distance less than or equal to the depth (invert) of the sewer main, shall be required to submit structural analysis and a geotechnical soil survey report with each signed and sealed by an Arizona Registered Professional Engineer. These reports shall be submitted to the City for review and approval. The reports shall verify the integrity of the proposed structure under the condition of a sewer main failure,

as well as verifying that the proposed structure and its foundations will not compromise the structural integrity of the sewer main.

Water or Force Main

Buildings, building slabs or structures proposed outside of the easement but parallel to a water main or sewer force main within 12 feet, shall be required to submit structural analysis and a geotechnical soil survey report, with each signed and sealed by an Arizona Registered Professional Engineer. These reports shall be submitted to the City for review and approval. The reports shall verify the integrity of the proposed structure under the condition of a water/sewer force main failure, as well as verifying that the proposed structure and its foundations will not compromise the structural integrity of the water/sewer force main.

NOTE: *The horizontal distance is measured from the edge of the building foundation to the outside of the water or sewer pipe.*

Exceptions:

Pre-Built/Fabricated Woodshed-type Structures

Pre-Built/Fabricated Aluminum Shed-type Structures

Pre-Built/Fabricated Shade Structures

Free-Standing Barbecue Islands

Enclosures to Existing Garage/Carport/Patio where the existing concrete slab and roof will not be altered

6. Allowable Plants and Trees within an Easement

For WSD's list of acceptable plants that can be located within an easement, refer to **Table 6**, *List of Acceptable Plants and Trees*. For a list of approved trees that can be placed within an easement, refer to Section C, item 2, of this chapter. ***NOTE:*** If an allowable tree is placed in an easement, it shall also meet the minimum separation requirement from a water or sewer main.

C. HORIZONTAL AND VERTICAL SEPARATION REQUIREMENTS

To minimize the potential for cross-contamination, water and sewer mains shall maintain a minimum horizontal and vertical separation. Horizontal separations are summarized in **Table 4**, *Water / Sewer Horizontal Separation Requirements*, and vertical separations are summarized in **Table 5**, *Water / Sewer Vertical Separation Requirements*.

Table 4. Water / Sewer Horizontal Separation Requirements.

Water / Sewer Horizontal Separation Requirement Table		TYPE OF PARALLEL UTILITY								
		Water Service Connection	Distribution Water Main	Transmission Water Main ¹	Sewer Main / Reclaimed Main	Sewer Service Connection	Dry Utilities ²	Private Fireline Service	Storm Drains / Culverts & Irrigation ²	Force Main
TYPE OF WATER/SEWER UTILITY	Distribution Water Main	3-feet minimum	3-feet minimum	3-feet minimum	6-feet minimum	6-feet minimum	6-feet minimum	3-feet minimum	6-feet minimum	6-feet minimum
	Transmission Water Main ¹	3-feet minimum	3-feet minimum	3-feet minimum	6-feet minimum	6-feet minimum	6-feet minimum	3-feet minimum	6-feet minimum	6-feet minimum
	Water Service Connection	5-feet minimum	3-feet minimum	3-feet minimum	6-feet minimum	6-feet minimum	3-feet minimum	3-feet minimum	3-feet minimum	6-feet minimum
	Private Fireline Service	3-feet minimum	3-feet minimum	3-feet minimum	6-feet minimum	6-feet minimum	6-feet minimum	3-feet minimum	6-feet minimum	6-feet minimum
	Sewer Main / Reclaimed Main	6-feet minimum	6-feet minimum	6-feet minimum	3-feet minimum	3-feet minimum	6-feet minimum	6-feet minimum	3-feet minimum	6-feet minimum
	Sewer Service Connection	6-feet minimum	6-feet minimum	6-feet minimum	3-feet minimum	3-feet minimum	3-feet minimum	6-feet minimum	3-feet minimum	6-feet minimum
	Force Main	6-feet minimum	6-feet minimum	6-feet minimum	6-feet minimum	6-feet minimum	6-feet minimum	6-feet minimum	6-feet minimum	4-feet minimum

¹ When running parallel to a Prestressed Concrete Cylinder Pipe (PCCP), the General Requirements for Working Around Prestressed Concrete Cylinder Pipe must be followed. See Section IV(D)(14).

² Minimum separation required by WSD. Utility owner may require a greater separation. Refer to the link in Appendix A, page A-2, for SRP Irrigation Requirements.

NOTE: This table applies to all above ground or underground utilities/structures. Separations are measured from outside of pipe to outside of pipe.

Table 5. Water / Sewer Vertical Separation Requirements.

Water / Sewer Vertical Separation Requirement Table		TYPE OF VERTICAL UTILITY								
		Water Service Connection	Distribution Water Main	Transmission Water Main ¹	Sewer Main / Reclaimed Main	Sewer Service Connection	Dry Utilities ⁴	Private Fireline Service	Storm Drains / Culverts & Irrigation ^{4, 6}	Force Main ⁵
TYPE OF WATER / SEWER UTILITY	Distribution Water Main Above Utility ³	6-inch minimum	1-foot minimum	2-feet minimum	1-foot Minimum ²	6-inch Minimum ²	1-foot minimum	1-foot minimum	1-foot Minimum ²	2-feet minimum
	Distribution Water Main Below Utility	6-inch minimum	1-foot minimum	2-feet minimum	2-feet Minimum ²	2-feet Minimum ²	1-foot minimum	1-foot minimum	2-feet Minimum ²	2-feet Minimum ²
	Transmission Water Main Above Utility ¹	2-feet minimum	2-feet minimum	2-feet minimum	2-feet minimum	2-feet minimum	2-feet minimum	2-feet minimum	2-feet minimum	2-feet minimum
	Transmission Water Main Below Utility ¹	2-feet minimum	2-feet minimum	2-feet minimum	2-feet Minimum ²	2-feet Minimum ²	2-feet minimum	2-feet minimum	2-feet Minimum ²	2-feet Minimum ²
	Private Fireline Service Above Utility	6-inch minimum	1-foot minimum	2-feet minimum	1-foot Minimum ²	6-inch Minimum ²	1-foot minimum	1-foot minimum	1-foot Minimum ²	2-feet minimum
	Private Fireline Service Below Utility	6-inch minimum	1-foot minimum	2-feet minimum	2-feet Minimum ²	2-foot Minimum ²	1-foot minimum	1-foot minimum	2-feet Minimum ²	2-feet minimum
	Water Service Connection Above or Below Utility	6-inch minimum	6-inch minimum	2-feet minimum	6-inch minimum	6-inch minimum	6-inch minimum	6-inch minimum	1-foot Minimum	2-feet minimum
	Sewer Main / Reclaimed Main Above Utility	6-inch minimum	2-foot Minimum ²	2-feet Minimum ²	1-foot Minimum	6-inch Minimum	1-foot minimum	2-feet Minimum ²	1-foot Minimum ²	2-feet Minimum
	Sewer Main / Reclaimed Main Below Utility	6-inch minimum	1-foot Minimum ²	2-feet Minimum	1-foot Minimum	6-inch Minimum	1-foot minimum	1-foot Minimum ²	1-foot Minimum	2-feet Minimum
	Sewer Service Connection Above	6-inch Minimum	2-foot Minimum ²	2-feet Minimum ²	6-inch Minimum	6-inch Minimum	6-inch minimum	2-feet Minimum ²	1-foot Minimum	2-feet Minimum
	Sewer Service Connection Below Utility	6-inch Minimum	6-inch Minimum ²	2-feet Minimum ²	6-inch minimum	6-inch minimum	6-inch minimum	6-inch Minimum ²	1-foot Minimum	2-feet Minimum
	Force Main ⁵	2-feet minimum	2-feet minimum	2-feet minimum	2-feet minimum	2-feet minimum	2-feet minimum	2-feet minimum	2-feet minimum	2-feet minimum

¹ When crossing Prestressed Concrete Cylinder Pipe (PCCP), the General Requirements for Working Around Prestressed Concrete Cylinder Pipe must be followed. See Section IV(D)(14).

² Extra protection is required for water mains and private fire line service that are between 1 and 2 feet above sewer main, storm drain or irrigation line, and less than 1 foot above a sewer service. Extra protection is required when water mains and private fire lines services are installed below sewer main and force main, regardless of distance. Extra protection is also required when water mains and private fire lines services are installed below storm drain or irrigation line. Minimum Separation and extra protection shall be in accordance with the requirements set forth in Arizona Administrative Code AAC R18-5-502, MAG Specification 610.1, and MAG Standard Detail No. 404-1; or as approved by WSD.

³ Where trenching operation crossed under existing 12 inch or smaller ACP Waterlines, Section 601.2.10 of the City Supplements to MAG must be followed. If trenching operations "expose" the ACP main, the ACP main shall be replaced with DIP.

⁴ Minimum separations required by WSD. Utility owners require a greater separation. Refer to the link in Appendix A, page A-2, for SRP Irrigation requirements.

⁵ Bypass operations team must be present onsite when crossing a force main less than the minimum separation and to be reviewed by a City professional engineer.

⁶ Any new water / sewer mains crossing below any size box culverts at any clearance shall be steel encased for a minimum of 10-ft on each side of the crossing, or as approved by WSD.

⁷ For separation between water mains and sewer force mains, the minimum vertical separation is 2-ft (outside to outside) under all conditions. If sewer force mains cross above water mains (at any vertical distance), or sewer force mains cross below water mains with less than 6-ft vertical clearance, A.A.C. Article 5 Section RI 8-5-502 requires extra protection of sewer force mains. For public force mains (most of the time HDPE pipelines), please consult with WSD about preferred extra protection methods. For private DIP force mains, WSD usually requires concrete encasement of the private force mains for minimum 10-ft beyond the crossing at both directions or throughout the ROW, whichever is less.

Note:

Clearances are measured from outside of pipe to outside of pipe.
Concrete encasement of VCP sewer mains is not allowed.

Extra protection for VCP gravity sewer mains alone can be achieved by utilizing one of the following two methods:

1. Method One: Replacing VCP sewer main from MH to MH with DIP sewer main with CIPP lining. The DIP sewer main must be either restrained minimum 6 ft beyond the crossing location at both directions, or has no joints for minimum 10 ft beyond the crossing location at both directions.
2. Method Two: CIPP lines the VCP sewer main from MH to MH.
3. Concrete encasement of new or existing VCP sewer mains as extra protection method is not allowed.

1. Separation Requirements from Water Supply System

While no general statement can be made to cover all conditions, it is recognized that sewers shall meet the requirements of the appropriate reviewing agency with respect to minimum distances from public water supply wells or other water supply sources and structures.

All existing waterworks units, such as basins, wells or other treatment units within 200 feet of the proposed sewer shall be shown on the plans.

2. Tree Separation Requirements

To protect the public water and sewer infrastructure, all trees shall maintain 10 feet horizontal separation measured from outside of pipe to the tree trunk. WSD may allow less than 10 feet but not less than 6 feet, if it meets the following criteria:

The existing or proposed tree(s) MUST be on **Table 6, List of Acceptable Plants and Trees**, or lists approved by the Walkable Urban Code or Downtown Code Zoning Districts.

NOTE: Any COP approved trees are allowed if located more than 10 feet away from a water or sewer main.

Table 6. List of Acceptable Plants and Trees.

ACCENTS/CACTI			
Botanical Name	Common Name	Botanical Name	Common Name
Agaves spp.	Century plant, agave	Ferrocactus cylindraceus	Barrel
Aizoaceae	Ice plant family	Fouquieria splendens	Ocotillo
Aloe spp.	Aloe	Hesperaloe parviflora	Hesperaloe
Bacillus cereus	Cereus	Manfreda maculosa	Manfreda
Cactaceae	Cactus Family	Opuntia	Prickly pear
Carnegieia gigantean	Saguaro	Pachycereus schottii	Senita
Cylindropuntia	Cholla	Pedilanthus macrocarpus	Lady slipper
Dasyliirion spp.	Desert spoon	Stenocereus thurberi	Organ pipe
Echinocereus triglochidiatus	Hedgehog	Xerophyllum tenax	Bear grass
Echinopsis pachanoi	Trichocereus	Yucca glauca spp.	Yucca

GROUNDCOVER			
Botanical Name	Common Name	Botanical Name	Common Name
Acacia redolens	Desert carpet trailing acacia	Gazania rigens "Sun Gold"	Gold gazania
Aloe barbadensis	Medicinal aloe	Lantana spp. "New Gold"	Yellow lantana "New Gold"
Aloe saponaria	Tiger aloe	Oenothera berlandieri	Mexican evening primrose
Ambrosia deltoidea	Triangle leaf bur-sage	Oenothera caespitosa	Tufted evening primrose
Ambrosia dumosa	White bur-sage	Oenothera stubbei	Saltillo Primrose
Artemisia ludoviciana	White sage	Rosemarinus officinalis "Prostratus"	Trailing rosemary
Asparagus densiflorus "Sprengerii"	Sprenger asparagus	Salvia chamaedryoides	Blue sage
Baccharis spp. "Twin Peaks"	Twin peaks coyote brush	Salvia coccinea	Sage
Bulbine frutescens	Bulbine	Santolina chamaecyparissus	Lavender cotton
Convolvulus mauritanicus	Ground morning glory	Santolina virens	Green santolina

GROUNDCOVER			
Botanical Name	Common Name	Botanical Name	Common Name
Dalea Capitata "Sierra Gold"	Yellow flowered trailing dalea	Teucrium chamaedrys 'Prostrata"	Germander
Dalea greggii	Trailing indigo bush	Verbena peruviana	Peruvian verbena
Ericameria laricifolia	Turpentine bush	Verbena rigida	Sandpaper verbena
Eriogonum fasciculatum	California buckwheat	Zephyranthes candida	Rain lily
Eriogonum wrightii	Buckwheat	Zinnia grandiflora	Rocky mountain zinnia

TREE TYPES ALLOWABLE – MINIMUM 6 FEET FROM WATER/SEWER MAIN			
Botanical Name	Common Name	Botanical Name	Common Name
Acacia aneura	Mulga	Ebenopsis ebano	Texas Ebony
Acacia coriacea	Desert Oak	Erythrina bidwillii	Bidwell's Coral Tree
Acacia brachybotrya	Grey Mulga	Eucalyptus erythrocorys	Red-cap Gum
Acacia berlandieri	Guajillo	Eysenhardtia orthocarpa	Kidneywood
Acacia constricta	White Thorn Acacia	Fraxinus greggi	Little-leaf Ash
Acacia craspedocarpa	Leather-Leaf Acacia	Havardia pallens	Tenaza
Acacia jennearae	Coonavitra Wattle	Leucaena retusa	Golden Leadball Tree
Acacia notabilis	Notable Wattle	Ligustrum japonicum	Japanese Privet
Acacia rigidula	Blackbrush Acacia	Lysiloma watsonii v. thronberi	Feather Bush
Bauhinia lunarioides	Anacacho Orchid Tree	Mariosuosa willardiana	Palo Blanco
Bauhinia mexicana	Orchid Tree	Phoenix canariensis	Canary Island Date Palm
Brahea armata	Mexican Blue Palm	Pistacia lentiscus	Mastic Tree
Caesalpinia cacalaco	Cascalote	Pittosporum angustifolium	Willow Pittosporum
Caesalpinia mexicana	Mexican Bird of Paradise	Punica granatum	Pomegranate
Calio secundiflora	Texas Mountain Laurel	Ungnadia speciosa	Mexican Buckeye
Chamaerops humilis	Mediterranean Fan Palm	Vauquelinia californica	Arizona Rosewood
Chilopsis linearis 'Lucretia Hamilton'	Desert Willow	Washingtoniafilifera	California Fan Palm
Cordia boissieri	Texas Olive	Washingtonia robusta	Mexican Fan Palm

SHRUBS			
Botanical Name	Common Name	Botanical Name	Common Name
Abutilon palmeri	Superstition mallow	Krameria parvifolia	Ratany
Aloysia spp.	Bee brush	Lantana camera	Bush lantana
Ambrosia spp.	Bur-sage	Larrea tridentata	Creasote bush
Asclepias linaria	Pine leaf milkweed	Leucophyllum spp.	Texas sage
Asclepias subulata	Desert Milkweed	Lippia berlandieri	Mexican oregano
Atriplex spp.	Saltbush	Maytenus phyllanthoides	Mangle dulce
Berberis haematocarpa	Red barberry	Mimosa biuncifera	Catclaw mimosa
Berberis trifoliolata	Agarita	Mimosa dysocarpa	Velvet pod mimosa
Buddleia marrubifolia	Wooly butterfly bush	Myrtus communis	True myrtle
Caesalpinia spp.	Bird of paradise	Myrtus communis 'Boetica"	Twisted myrtle
Calliandra californica	Baja red fairy duster	Myrtus communis 'Compacta'	Dwarf myrtle
Calliandra eriophylla	Fairy duster	Nandina domestica	Heavenly bamboo
Calliandra peninsularis	Red fairy duster	Nerium oleander 'Dwarf'	Dwarf oleander
Callistemon phoeniceus	Salt resistant bottlebrush	Perovskia atriplicifolia 'Heavenly Blue'	Russian sage
Callistemon viminalis "Captain Cook"	Dwarf bottlebush	Plumbago scandens	Plumbago
Calothamnus spp.	Net bush	Punica granatum 'Dwaft'	Dwarf pomegranate
Cassia (Senna) spp.	Cassia	Pyracantha spp.	Firethorn (susceptible to fireblight)
Chrysothamnus mexicana	Damianita	Rhus choriophylla	Mearns sumac
Chrysothamnus nauseosus	Rabbit bush	Rhus microphylla	Desert sumac
Cistus spp.	Rockrose	Rhus ovata	Sugarbush
Condalia globosa	Bitter condalia	Rhus trilobata	Skunk bush
Convolvulus cneorum	Bush morning glory	Rhus virens	Evergreen sumac
Cordia boissieri	Anacahuita	Rosmarinus officinalis	Rosemary

SHRUBS			
Botanical Name	Common Name	Botanical Name	Common Name
Cordia parvifolia	Little leaf Cordia	Ruellia californica	Ruellia
Dalea spp.	Indigo bush	Reullia peninsularis	Ruellia
Encelia spp.	Brittle bush	Salvia spp.	Sage
Ephedra spp.	Mormon tea	Simmondsia chinensis	Jojoba
Eremophila spp.	Emu bush	Solanum xanti	Solanum
Ericameria linearifolia	Turpentine bush	Sophora arizonica	Arizona sophora
Erythrina flabelliformis	Southwest coralbean	Sophora formosa	Sophora
Euphorbia antisiphilitica	Wax plant, candelilla	Tecoma stans	Yellow bells
Euphorbia rigida	Euphorbia	Tecomaria capensis	Cape honeysuckle
Fraxinus greggii	Little leaf ash	Teucrium fruticans	Bush germander
Genista hispanica	Spanish broom (Self-propagating)	Thamnosma montana	Turpentine broom
Gutierrezia microcephala	Snakeweed	Trixis californica	Trixis
Hamela patens	Fire bush	Vauquelinia californica	Rosewood
Hyptis emoryi	Primrose jasmine	Viguiera deltoidea	Golden eye
Jatropha spp.	Limberbush	Vigueira tomentosa	Golden eye
Justicia spp.	Chuparosa	Westringia rosmarinaformis	Westringia

VINES			
Botanical Name	Common Name	Botanical Name	Common Name
Antigonon leptopus	Coral vine, queen's wreath	Mascagnia lilacina	Purple Mascagnia
Bougainvillea spp.	Bougainvillea	Maurandya antirrhinifolia	Snapdragon vine
Calleaum macropterum (Mascagnia macroptera)	Yellow orchid vine	Maurandya wislizeni	Snapdragon vine
Campsis radicans	Trumpet creeper	Merremia aurea	Yellow morning glory
Cissus trifoliata	Grape ivy	Podranea risasoliana	Pink trumpet vine
Clematis drummondii	Virgin's bower	Rhynchosia texana	Rosary bead vine
Hardenbergia comptoniana	Wild wisteria	Rosa banksiae	Lady bank's rose
Kennedia nigricans	Black yellow vine	Solanum jasminoides	Potato vine
Macfadyena unguis-cati	Cat's claw		

Once an approved tree is selected, it shall be planted between 6 and 10 feet from a water/sewer main and the developer shall install a root barrier between the tree roots and the water/sewer main. Refer to **Figure 3, Tree Root Barrier Detail**, for the installation.

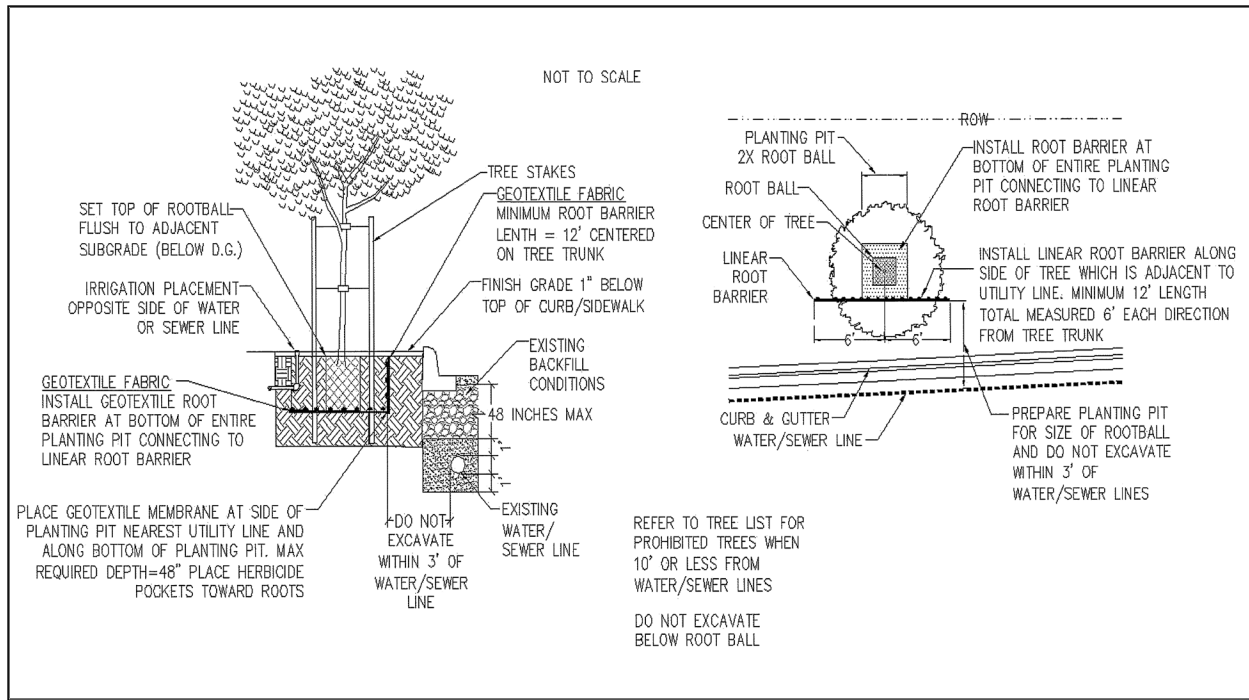

Figure 3. Plant Root Barrier Detail.

TREE ROOT BARRIER DETAIL NOTES:

Geotextile Fabric with Herbicide Nodules: Install per manufacturer's specifications. Length and depth per detail above. Root barriers to be installed from top of subgrade to a maximum depth 48-inches. Install at edge of trench with chemical pockets towards roots.

Geotextile fabric shall consist of long chain synthetic polyolefins (minimum 95% by weight) and contain a UV stabilizer. Herbicide nodules chemical composition that are attached to the geotextile fabric shall consist of time-released trifluralin (17.5% in total composite, minimum of 20% trifluralin in nodules).

DO NOT excavate below root ball depth in planting pit. If soil is disturbed below root ball depth in planting pit, then soil **SHALL** be tamped to 85% compaction.

D. SUBMITTALS

1. Water and Sewer Master Plans, Reports, and Requirements

Water and wastewater master plan and design reports play a critical role in evaluating the capacity and functionality of both existing and future water and wastewater systems within the Master Planned Area and its surrounding regions. These reports validate that proposed system upgrades are sufficient to meet the demands of future residents and businesses by providing adequate water supply and fire flow, or sewer capacity.

The reports typically include visual representations, such as maps or diagrams, detailing the types and locations of planned infrastructure improvements. Both Planned Community Districts (PCD) and Planned Unit Development (PUD) Districts must submit water and/or wastewater master plan and design reports. These master plans are essential to define the specific improvements required and the sequence in which they must be implemented prior to securing the vesting of PCD/PUD overlay zoning.

For guidance regarding PCD/PUD requirements, consult the PDD. However, it is important to note that the WSD may still mandate the submission of water and wastewater master plan reports for multi-phased, large-scale or complicated developments outside of the PCD/PUD framework. This is especially true for projects necessitating substantial off-site infrastructure, even in cases where PDD may not specifically request a master plan report.

Master plan design reports differ from water and wastewater design reports primarily due to the larger scale and greater complexity of master-planned communities. These communities typically include multiple land use zones, phased developments, and potentially more advanced infrastructure requirements, such as booster stations, reservoirs, lift stations, and/or treatment facilities. For commercial or residential developments that do not meet these conditions and are not PCD/PUD developments, consult with the WSD and PDD on whether your project requires master plan design reports or simply water and wastewater design reports. Refer to Section III.D.2, Design Reports, for guidelines on development of water and wastewater design reports.

- a. Requirements for water master plan and design reports: Water master plans and design reports should be prepared as 8.5" x 11" (PDF) documents. Exhibits and drawings may be printed on larger formats such as 11" x 17" or 24" x 36". The use of color in exhibits is strongly encouraged to enhance clarity. Gray-scale shading is discouraged, as it often reproduces poorly. If color cannot be used, cross-hatching is recommended as an alternative. The water master plan report must be sealed and signed by a Professional Civil Engineer licensed in the State of Arizona. At a minimum, the water master plan report must include:

Title Page

The title page should include:

- Name of the master plan.
- Rezoning application number (if applicable).
- Date the plan was prepared (and date of any revisions).
- Developer's name, address, phone number, and email.
- Engineer's name, address, phone number, and email.
- SDEV, KIVA, and PAPP numbers, if applicable.

Approval Page

The approvals page should be bound into the report and include space for the following approval signatures:

- Principal Engineer, with seal from an Arizona Registered Civil Engineer.
- Developer/Owner.

CITY OF PHOENIX APPROVAL	
<input type="checkbox"/> Original <input type="checkbox"/> Amendment _____	
_____ Water Services Director	_____ Date
_____ Planning & Development Director	_____ Date

CONSENT FOR REPRODUCTION	
I consent to the reproduction of this Master Plan for the purpose of future amendments, provided that if modifications are made the architects/engineers who make such changes assume full responsibility and liability for the changes made to the plan.	
_____ Name (printed) of copyright owner	
_____ Signature of copyright owner	_____ Date

Table of Contents

- Provide a table of contents for the report.
- Provide a list of tables and figures.
- Provide a list of appendices.

Introduction

The introduction should provide descriptions under the following headings:

- General Description - including description of the proposed development, proposed land uses, overall development phases and timeline, total number of phases, dwelling units and/or square footage under each phase, zoning approvals and dates, case numbers, and descriptions of all stipulations applied by the zoning case. Provide documentation of annexation if not presently within the City of Phoenix.
- Scope of work - describe the overall water system requirements for the development.
- Project location - provide project location information such as section, township, range, and major street corridors.

Vicinity Map

Vicinity maps should include the following information:

- Show all major streets or alignments on the development's perimeter.
- Describe major physical features as applicable, including canals, freeways, major washes, railroads, etc.
- Include a north arrow and scale bar.
- Shade development boundaries using color, cross-hatching, or other methods.
- Size maps as 8-1/2" x 11" documents, when possible.

Summary of Design Criteria

Provide a summary of the water system design criteria as well as the codes, standards, and guideline documents referenced to establish the minimum acceptable performance requirements for the Water Master Plan design.

Land Use/Population Projections

Provide a comprehensive land use table and a projected population table. Use **Table 7** and **Table 8** below as references, modifying the table headers as necessary to reflect the specific data requirements for each type of development unit (e.g., commercial land uses may require different categories of information than residential land uses). Include a detailed narrative explaining the methodology used to calculate population and/or employment growth for each development phase and the final buildout of the project.

Table 7. Example Land Use Plan Data.

Development Unit	Land Use	Zoning ¹	Dwelling Units/Lots per Acre ²	Gross Acres (Acres) ³	Number of Dwelling Units (DU) ⁴	Development Phase
TOTALS						

¹ Zoning is per City of Phoenix Ordinance and Project stipulations.

² The dwelling units per acre and/or lot coverage are based on the City of Phoenix Zoning Ordinance and other stipulations prepared for this project.

³ The areas shown in this column are based on the areas shown on the approved Master Development Plan or Land Use Plan and are estimated to the nearest acre.

⁴ The number of dwelling units is based on the areas as shown on the approved Land Use Plan (3) and the units per acre as defined by the City of Phoenix Zoning Ordinance (2).

Table 8. Example Projected Population Table [for Phase Number _____].

Development Unit	Land Use	Number of Dwelling Units (DU)	Density (People/DU)	Population (People)
TOTALS				

Water Demand Projections

Create a table summarizing the water demand for each phase of development. Refer to **Table 9** below for an example table for a single development phase. The table must incorporate the maximum day demand and peak hour demand as specified in Section III.E, Water Demand and Sewer Design Flows.

Include the fire flow requirements for each development unit and each phase of the development, complying with the current City of Phoenix Fire Code and this WSD Design Standards Manual for Water and Wastewater Systems.

Table 9. Example Water Demand Calculations [for Phase Number _____].

Dev. Unit	Zoning	Gross Acres (Acres)	Water Pressure Zone	Land Use	Unit ⁽¹⁾	Water Average Daily Flow/Unit ⁽²⁾ (gal)	Average Daily Demand (gpm)	Peak Daily Demand ⁽³⁾ (gpm)	Maximum Fire Flow ⁽⁴⁾ (gpm)	Peak Hour Demand (gpm)
TOTALS										

¹ Refer to the 2026 City of Phoenix Design Standards Manual (DSM 2026) **Table 8**. Example units include dwelling, 1000 ft², student, room, bed, acre.

² Values to be calculated using DSM 2026 **Table 8**.

³ Peak daily demand is calculated as 1.7 times the average daily demand.

⁴ For fire flow demands, refer to the currently adopted City of Phoenix Fire Code.

Existing Water System Descriptions and Locations

Provide the following information on the existing water system (only public system). This information may be provided in the report as well as shown on an exhibit or on the Water Master Plan Drawings (described below).

- Provide a detailed description and location of all existing water facilities in the vicinity of the development, with a specific focus on the infrastructure that will serve the project. Clearly identify facilities that have the capacity to meet the development's demands, as determined through the Engineers' computer modeling. This may include reservoirs, booster stations, pressure reducing valve (PRV) stations, as well as transmission and distribution lines.
- Pressure zone(s) in which the development will be located.
- Contour elevations throughout the development and the boundary of the City of Phoenix pressure zone(s).

Proposed Water System Improvements

The following system improvements should be shown or described in the report.

- Provide a narrative and description of all on and off-site water facility improvements serving the development in all phases. This may include narrative discussion of water source, water treatment, etc. Include any pertinent information related to the water improvements that impact phasing, construction, land use issues, dedications, facility sizing, utility and paving conflicts, etc.

- Include modeling results for the various phases of the project in narrative format. Text should address the impact on existing water systems as well as proposed improvements.
- Provide hydraulic calculations for water facilities such as reservoirs, pump stations, and pressure reducing valve stations. The WSD will determine if additional water facilities are needed based upon existing facility capacity. This determination will be established from the development's peak day water demands, fire flow requirements, and its location within the water service area.
- If the development falls into an area where the City has established a regional Water System Master Plan (WSMP), the development's water master plan must comply with the WSMP according to WSD's stipulations and may not need conduct detailed hydraulic modeling analysis. Provide location and sizes of all water facilities if applicable (e.g., booster pump stations, reservoirs, pressure reducing valve stations, production wells, recharge facilities, etc.).
- Provide sizes and preliminary alignments of water distribution mains and water transmission mains (if applicable).

Water infrastructure needs must be based on a phased approach and the ultimate water infrastructure needs must be based on the built-out scenario of the development. Water master plans should include all the local and regional water infrastructures needed inside and outside of the development boundary to support the build-out scenario.

NOTE: *In compliance with City of Phoenix Code §37-33, the developer is responsible for constructing all water mains, service connections, valves, fittings, and related appurtenances within the development boundaries and along the streets surrounding the entire development, in addition to those lines identified on the master plan. Furthermore, the developer must furnish and install all offsite water mains required to establish a looped connection to the existing water mains.*

Water System Modeling of Proposed Improvements

Unless approved by WSD, data and modeling results shall be included as an appendix with the report, and results summarized in the body of the report. At a minimum, this appendix should include:

- The scenarios to be modeled should include peak day demand plus fire flow and peak hour demand of the peak day. This guideline may not comprehensively address every development scenario. The WSD will provide further clarification for any identified special circumstances that may require additional scenario development and modeling.
- Copy of input data and output results for the simulations of each phase of the development. This should include information such as figures, input model parameters, output results, etc. Provide data within appendices.
- Model data should be arranged in tables that comprehensively detail the ID names and associated attributes for all components within the model. These components include, but are not limited to, pipes, nodes, pumps, tanks, valves, and similar elements. Attribute data should encompass pertinent details such as:
 - Pipes: ID, connection nodes IDs, diameters, roughness coefficients, hydraulic grade elevations, velocity, flow, head loss, water pressure zone, etc.
 - Nodes: ID, connection pipes, elevation, hydraulic grade line, residual pressure, water service node, water pressure zone, etc.
 - Reservoirs/Tanks: ID, flow, elevation, water pressure zone, etc.

- Pumps: ID, pump flow rates, pump settings, elevation, etc.
- Valves: valve statuses (open/closed), flow, hydraulic grade, valve setting, etc.
 - For node demands, clearly specify the flow scenario to which the demand applies.
 - The output results should present results for each flow scenario.
- Provide a brief description of any assumptions being made for each simulation.
- Modeling simulations for each phase of the development shall be designed to operate independently from each other, and each phase must meet Phoenix City Code, policies, and design criteria outlined in this WSD Design Standards Manual for Water and Wastewater Systems.
 - Modeling simulations shall not include any private water infrastructure.
- Residual Pressure and Velocity Requirements:
 - Phoenix City Code requires that:
 - A minimum of 50 psi and a maximum of 100 psi of residual pressure at the service meter and velocity of less than or equal to 5 fps be maintained during peak day conditions.
 - A minimum of 25 psi of residual pressure at the service meter and velocity of less than or equal to 10 fps be maintained during a fire flow event.
- Electronic copies of files used for simulations shall be provided upon WSD request.

Phasing Schedule

A phasing schedule shall be included in a table or a combination of table/map format. The table shall show individual phases in column headings and parcels in sequence in sub-column headings under each phase with the related water system components itemized in row headings. The table shall indicate when each water component will be built for the individual parcels and associated responsible party. A separate table shall be included summarizing both the initiation and completion of each phase. An overall map or maps showing all the phasing with the corresponding parcels and water infrastructures shall be provided.

Planning Level Cost Estimate

Provide a planning-level cost estimate of the proposed water system improvements and facilities for each phase of the development if specifically required by the zoning stipulation or by the City. The City publishes “Water and Wastewater Unit Cost Study” every five years, and the latest version is posted on the following website: [Planning and Development Proposed 2025 Infrastructure Financing Plan](#)

Summary and Conclusions

Provide a final summary and conclusions confirming the proposed improvement will maintain acceptable operational conditions for the existing and proposed water systems improvements for the required flow model conditions.

Water Master Plan Drawing(s)

A full-size copy of the Water Master Plan drawing(s) shall be included with the report. At a minimum, the drawing must include:

- Size shall be 24” x 36”.
- The use of color is highly encouraged. Shading using a grayscale is discouraged as it often does not show well when reproduced. In such cases where color cannot be used, cross-hatching is instead recommended.

- The preferred scale used for the Water Master Plan drawing shall be 1" = 200'. Depending on the size of the development, 1" = 300' or 1" = 400' may be appropriate as well. In any case, a standard scale should be used that shows the entire Master Planned Area on the cover sheet of the drawings. Any accompanying detail sheets shall utilize an appropriate and logical scale which clearly shows the proposed improvements for plan-view drawings.
- Each sheet shall be signed and sealed by a Professional Civil Engineer registered in the State of Arizona.
- Provide a vicinity map which shows the location of the development within the surrounding +/- 10 square miles, with clear and labeled references to the nearest arterial streets and freeways. Include a north arrow.
- Include a title block with the following information:
 - Name of the PCD/PUD/Development.
 - Zoning case number(s).
 - Development Services Department tracking numbers (when available).
 - Developer's name, address, phone number, and email address.
 - Name of engineer that prepared the plan including firm name, address, phone number, and email address.
 - Date the plan was prepared and dates of any revisions.
- Include the following approval/signature blocks in the lower-right hand corner of the drawing cover page.

CITY OF PHOENIX APPROVAL	
<input type="checkbox"/> Original <input type="checkbox"/> Amendment _____	
Water Services Director	Date
Planning & Development Director	Date

CONSENT FOR REPRODUCTION	
I consent to the reproduction of this Master Plan for the purpose of future amendments, provided that if modifications are made the architects/engineers who make such changes assume full responsibility and liability for the changes made to the plan.	
Name (printed) of copyright owner	
Signature of copyright owner	Date

- Provide a legend that accurately illustrates symbols utilized to illustrate the Water Master Plan. The following symbols should be provided, at a minimum:
 - Perimeter boundary lines of the Master Planned Area covered by this plan (i.e., PUD/PCD/Functional Segment Boundary).
 - Boundary lines of each development unit.
 - Right-of-way boundary lines.
 - Easement boundaries.
 - Monument lines.
 - Existing water lines.
 - Proposed new water lines.
- The following items, as a minimum, shall be included on a plan view of the Water Master Plan. **The intent of the plan view is to accurately illustrate the location(s) and type(s) of future water lines and facilities that shall be installed.**
 - Locations of everything stated under the legend above.

- A label for each development unit, i.e. "Parcel 2"; "Development Unit B", or similar.
- Arterial streets, with assumed (or suggested) names.
- Collector streets, with assumed (or suggested) names.
- Any existing water facilities.
- Any proposed improvements extending beyond the master planned area boundary.
- Other major features such as canals, major overhead power, bridge crossings, and major washes, etc.
- Contour elevations on 10-foot intervals for pressure zone determinations. Identify all pressure zone boundaries and label.
- Pipe segments and demand node data with labels corresponding to modeling simulations.
- Site locations of all water facility improvements such as reservoirs, pumping stations and/or pressure reducing stations.
- **Do NOT show any proposed subdivision lotting patterns or internal subdivision distribution lines.** Local street locations and the water distribution system and will be determined at the time of Preliminary Site Plan Approval for the specific Development Unit within the Master Planned Area.

Requirements for Wastewater Master Plan and Design Reports

Wastewater Master Plans and Design Reports should be prepared as 8.5" x 11" (pdf) documents. Exhibits and drawings may be printed on larger formats such as 11" x 17" or 24" x 36". The use of color in exhibits is strongly encouraged to enhance clarity. Gray-scale shading is discouraged, as it often reproduces poorly. If color cannot be used, cross-hatching is recommended as an alternative. The Wastewater Master Plan Report must be sealed and signed by a Professional Civil Engineer licensed in the State of Arizona.

At a minimum, the Wastewater Master Plan report must include:

Title Page

The title page should include:

- Name of the master plan.
- Rezoning application number (if applicable).
- Date the plan was prepared (and date of any revisions).
- Developer's name, address, phone number, and email.
- Engineer's name, address, phone number, and email.

Approval Page

The approvals page should be bound into the report and include space for the following approval signatures:

- Principal Engineer, with seal from an Arizona Registered Civil Engineer.
- Developer/Owner.

CITY OF PHOENIX APPROVAL	
<input type="checkbox"/> Original <input type="checkbox"/> Amendment _____	
<hr/>	
Water Services Director	Date
<hr/>	
Planning & Development Director	Date

CONSENT FOR REPRODUCTION	
I consent to the reproduction of this Master Plan for the purpose of future amendments, provided that if modifications are made the architects/engineers who make such changes assume full responsibility and liability for the changes made to the plan.	
<hr/>	
Name (printed) of copyright owner	
<hr/>	
Signature of copyright owner	Date

Table of Contents

Provide a table of contents for the report.

- Provide a table of figures.
 - Provide a list of Appendices.

Introduction

The introduction should provide descriptions under the following headings:

- General Description - including description of the proposed development, proposed land uses, overall development phases and timeline, total number of phases, dwelling units and/or square footage under each phase, zoning approvals and dates, case numbers, and descriptions of all stipulations applied by the zoning case. Provide documentation of annexation if not presently within the City of Phoenix.
- Scope of work - describe the overall wastewater system requirements.
- Project location - provide project location information such as section, township, range, and major street corridors.

Vicinity Map

- Vicinity maps should include the following information:
 - Show all major streets or alignments on the development's perimeter.
 - how major physical features if applicable, for example: canals, freeways, major washes, railroads, etc.
 - Include north arrow and scale.
 - Shade development boundaries using cross-hatching, color, or other methods.
 - Size map reasonably on an 8-1/2" x 11" size paper.

Summary of Design Criteria

Provide a summary of the design criteria as well as the codes, standards, and guideline documents referenced to establish the minimum acceptable performance requirements for the Wastewater Master Plan design.

Land Use/Population Projections

Provide a comprehensive land use table and a projected population table. Use **Table 10** and **Table 11** below as references, modifying the table headers as necessary to reflect the specific data requirements for each type of development unit (e.g., commercial land uses may require different categories of information than residential land uses). Include a detailed narrative explaining the methodology used to calculate population and/or employment growth for each development phase and the final buildout of the project.

Table 10. Example Land Use Plan Data.

Development Unit	Land Use	Zoning ⁽¹⁾	Dwelling Units/Lots per Acre ⁽²⁾	Gross Acres ⁽³⁾ (Acres)	Number of Dwelling Units ⁽⁴⁾ (DU)	Development Phase
TOTALS						

- ¹ Zoning is per City of Phoenix Ordinance and Project stipulations.
- ² The dwelling units per acre and/or lot coverage are based on the City of Phoenix Zoning Ordinance and other stipulations prepared for this project.
- ³ The areas shown in this column are based on the areas shown on the approved Master Development Plan or Land Use Plan and are estimated to the nearest acre.
- ⁴ The number of dwelling units is based on the areas as shown on the approved Land Use Plan (3) and the units per acre as defined by the City of Phoenix Zoning Ordinance (2).

Table 11. Example Projected Population Table⁽¹⁾ [for Phase Number _____].

Development Unit	Land Use	Number of Dwelling Units (DU)	Density (People/DU)	Population (People)
TOTALS				

- ¹ Provide table for each outfall, if there are more than one.

Wastewater Flow Projections

Prepare a table summarizing the unit flow rates for various land use types, as specified in Section III.E.1, Water and Sewer Design Flows. For any land use types that do not directly align with the categories defined in Section III.E.1, include a narrative explaining the rationale used to develop the corresponding flow rates.

Develop another table summarizing the projected wastewater flows for each phase of the development. Use **Table 12** as a reference for content. The flow projections shall conform to the wastewater design flow criteria outlined in Section III.E, Water Demand and Sewer Design Flows.

Table 12. Example Wastewater Flow Calculations⁽¹⁾ [for Phase Number _____].

Dev. Unit	Zoning	Gross Acres	Sewer Outfall	Land Use	Unit ²	Unit Wastewater Flow Unit ³ (gal)	Peaking Factor ⁴	Average Daily Flow (gpd)	Peak Flow ⁵ Flow (gpd)
TOTALS									

¹ Provide table to each outfall, if there are more than one.

² Refer to the DSM 2026 **Table 8**. Example units include dwelling, 1,000 ft², student, room, bed, acre.

³ Values to be calculated using DSM 2026 **Table 8**.

⁴ Peaking factors should be calculated from Harmon's formula: $[1 + 14/(4+P^{1/2})]$, where P = Population/1,000. For non-residential development, the Harmon's equation can be applied in some cases by assuming an 80 gallons per capita wastewater generation rate and converting the average daily flow to an equivalent population that can be used to calculate a peaking factor. In other cases, non-residential peaking factors should be based on performance data (i.e., estimated pool backwash or cooling tower blow down rates) and shall be confirmed with WSD staff prior to incorporating into the modeling and system analysis.

⁵ Peak flow is calculated as the product of the peaking factor and the average daily flow (unless otherwise noted).

Existing Wastewater System Description

Provide the following information on the existing wastewater system. This information may be shown on an exhibit or on the Wastewater Master Plan Drawings (described below).

- Provide a detailed description, location, and capacity of all existing wastewater facilities in the vicinity of the development, with a specific focus on the infrastructure that will serve the project. Clearly identify facilities that have the capacity to meet the development's demands, as determined through the Engineers' computer modeling. This may include gravity collection and interceptor pipes as well as wastewater force mains, manholes, lift stations, or treatment facilities.
 - Describe and identify the expected points of connection for the project using existing City of Phoenix manhole identification numbers.
- Contour elevations throughout the development.

Proposed Wastewater System Improvements

The following system improvements should be shown or described in the report.

- Provide a narrative and description of all on and off-site wastewater facility improvements serving the development in all phases. This may include wastewater treatment, wastewater reclaim, recharge and reuse plans, etc. Include any pertinent information related to the wastewater improvements that impact phasing, construction, land use issues, dedications, facility sizing, utility and paving conflicts, etc.
- Include a table of all manholes within the development that will be added to the City's system. The development manholes should have IDs that correlate to an exhibit (or exhibits) that are to be included in the report. The development manhole table should identify the average daily and peak flow applied at each manhole. If additional flows beyond average and peak are applied at a development manhole, these should also be identified in the development manhole table.
- Include a table of all pipes within the development that will be added to the City's system. The development pipes should have IDs that correlate to an exhibit (or exhibits) that are to be included in the report. For each development pipe, the cumulative average daily flow in the pipe shall be calculated and included in the table. The peak flow for each development pipe should be calculated and included

in the table. This calculated peak flow value shall be used to size each development pipe.

- Include modeling results for the various phases of the project in narrative format. Text should address the impact on existing wastewater systems as well as proposed improvements.
- Provide hydraulic calculations for wastewater facilities such as gravity pipes and lift stations.
- Describe the impact of the project on existing wastewater facilities.
- If the development falls into an area where the City has established a regional Wastewater System Master Plan (WWSMP), the development's wastewater master plan must comply with the WWSMP according to WSD's stipulations and may not need conduct detailed hydraulic modeling analysis.
- Provide location and sizes of all wastewater facilities if applicable (e.g., lift stations and recharge facilities, etc.).
- Provide sizes and preliminary alignments of wastewater collection mains, reclaimed water mains (if applicable), and wastewater interceptor mains (if applicable).

Wastewater infrastructure needs must be based on a phased approach and the ultimate wastewater infrastructure needs must be based on the built-out scenario of the development. Wastewater master plans should include all the local and regional wastewater infrastructures needed inside and outside of the development boundary to support the build-out scenario.

Wastewater System Modeling of Proposed Improvements

Unless approved by WSD, data and modeling results shall be included as an appendix with the report, and results summarized in the body of the report. At a minimum, this appendix should include:

- Modeling for the development shall be for peak day flow.
- Copy of input data and output results for the simulations of each phase of the development. This should include information such as figures, input model parameters, output results, etc. Provide data within appendices.
 - Model data should be organized in tables that comprehensively list the ID names and attributes for all components in the model, including pipes, manholes, lift stations, and similar elements. The attribute data should include relevant details such as start/end nodes (manholes), lengths, slopes, pipe diameters, manning coefficients, invert elevations, and wastewater service points/collection nodes.
 - The output results should be presented in the same tables, with pipe results detailing system model flow, velocities, d/D ratios, and pipe full flow capacity (when d/D=1.0) for gravity pipes. For pressurized force mains, pipe results should detail flow rates and velocities.
- Input and output files shall contain a brief description of assumptions being made for each simulation.
- Modeling simulations for each phase of the development shall be designed to operate independently from each other, and each phase must meet Phoenix City Code, policies, and design criteria outlined in this WSD Design Standards Manual for Water and Wastewater Systems.
- Electronic copies of files used for simulations shall be provided upon WSD request.

Phasing Schedule

A phasing schedule shall be included in a table or a combination of table and maps format. The table shall show individual phases in column headings and parcels in sequence in sub-column headings under each phase, with the related wastewater system components itemized in row headings. The table shall indicate when each wastewater component will be built for the individual parcels and the associated responsible party. A separate table shall be included summarizing both the initiation and completion of each phase. An overall map or maps showing all the phasing with the corresponding parcels and wastewater infrastructures shall be provided.

Planning Level Cost Estimate

Provide a planning level cost estimate of the proposed wastewater system improvements and facilities for each phase of the development if specially required by zoning stipulation or the City. The City publishes "Water and Wastewater Unit Cost Study" every five years and the latest version is posted on the following website: [Planning and Development Proposed 2025 Infrastructure Financing Plan](#).

Summary and Conclusions

Provide a final summary and conclusions confirming the proposed improvement will maintain acceptable operational conditions for the existing and proposed wastewater systems improvements for the required flow model conditions.

Wastewater Master Plan Drawing(s)

A full-size copy of the Wastewater Master Plan drawing(s) shall be included in the report. At a minimum, the drawing must include:

- Size shall be 24" x 36".
- The use of color is highly encouraged. Shading using a grayscale is discouraged as it often does not show well when reproduced. In such cases where color cannot be used, cross-hatching is instead recommended.
- The preferred scale used for the Wastewater Master Plan drawing shall be 1" = 200'. Depending on the size of the development, 1" = 300' or 1" = 400' may be appropriate as well. In any case, a standard scale should be used that shows the entire Master Planned Area on the cover sheet of the drawings. Any accompanying detail sheets shall utilize an appropriate and logical scale which clearly shows the proposed improvements for plan-view drawings.
- Each sheet shall be signed and sealed by a Professional Civil Engineer registered in the State of Arizona.
- Provide a vicinity map which shows the location of the development within the surrounding +/- 10 square miles, with clear and labeled references to the nearest arterial streets and freeways. Include a north arrow.
- Include a title block with the following information:
 - Name of the PCD/PUD/Development.
 - Zoning case number(s).
 - Development Services Department tracking numbers (when available).
 - Developer's name, address, phone number, and email address.
 - Name of engineer that prepared the plan including firm name, address, phone number, and email address.
 - Date the plan was prepared and dates of any revisions.

- Include the following approval/signature blocks in the lower-right hand corner of the drawing cover page.

CITY OF PHOENIX APPROVAL	
<input type="checkbox"/> Original <input type="checkbox"/> Amendment _____	
_____ Water Services Director	_____ Date
_____ Planning & Development Director	_____ Date

CONSENT FOR REPRODUCTION	
I consent to the reproduction of this Master Plan for the purpose of future amendments, provided that if modifications are made the architects/engineers who make such changes assume full responsibility and liability for the changes made to the plan.	
_____ Name (printed) of copyright owner	
_____ Signature of copyright owner	_____ Date

- Provide a legend that accurately illustrates symbols utilized to illustrate the Wastewater Master Plan. The following symbols should be provided, at a minimum:
 - Perimeter boundary lines of the Master Planned Area covered by this plan (i.e., PUD/PCD/Functional Segment Boundary)
 - Boundary lines of each development unit.
 - Right-of-way boundary lines.
 - Easement boundaries.
 - Monument lines.
 - Existing wastewater pipes (with direction of flow).
 - Proposed new wastewater pipes (with direction of flow).
- The following items, as a minimum, shall be included on a plan view of the Wastewater Master Plan. **The intent of the plan view is to accurately illustrate the location(s) and type(s) of future wastewater lines and facilities that shall be installed.**
 - Locations of everything stated under the legend above.
 - A label for each development unit, i.e., "Parcel 2"; "Development Unit B", or similar.
 - Arterial streets, with assumed (or suggested) names.
 - Collector streets, with assumed (or suggested) names.
 - Any existing wastewater facilities.
 - Any proposed improvements extending beyond the master planned area boundary.
 - Other major features such as canals, major overhead power, bridge crossings, and major washes, etc.
 - Contour elevations on 10-foot intervals. Include wastewater basin delineation boundaries (if applicable).
 - Pipe segments and flow input node data with labels corresponding to modeling simulations.
 - Site locations of all wastewater facility improvements such as manholes, cleanouts, lift stations, force mains, and/or diversion structures.
 - **Do NOT show any proposed subdivision lotting patterns or internal subdivision distribution lines.** Local street locations and the wastewater distribution system and will be determined at the time of Preliminary Site Plan Approval for the specific Development Unit within the Master Planned Area.

2. Design Reports

The objective of a water and sewer design report is to verify the design demands of the proposed development. All developments requiring public water and sewer main extensions must provide a design report along with the design plan submittal. Design reports shall provide calculations for the projected wastewater flows and water demand, describe the proposed development and basis of design; provide design data and hydraulic calculations that demonstrate the adequacy of the design to meet water and wastewater design standards. Design reports shall be signed and sealed by an Arizona registered professional engineer.

The design reports should include the following:

a. **Project Description**

1. Type of land use - e.g., commercial, residential, mixed use.
2. Provide the number of lots or units.
3. Provide a site map/location of the development showing major (arterial) streets and physical features such as canals, floodplains, railroads, washes, water and sewer infrastructure, and any information needed to gain a clear understanding of the project.
4. Phasing – identify the phase lines if applicable.

b. **Design Flows/Modeling**

Flow projections shall be based on **Table 14, Water and Wastewater Design Flows**.

Sewer:

1. Provide the design average and design peak flows for the sewage collection system. The basis of the projection of initial and future flows shall be included and must be based upon the initial service area and the ultimate upstream service area that can be served by gravity even if it is outside a development's project area.
2. Provide the basis of design for the sewage collection system including pipe sizes and slopes. Include the sizing calculations and calculations showing that there is sufficient hydraulic capacity to transport the design flows at the proposed sizes and slopes.
3. Must maintain d/D ratio of less than 0.75 at the peak flow condition for gravity sewer pipes and meet all gravity sanitary sewer main requirements in Chapter V, Wastewater Collection System.

Water:

1. Peak flow + fire flow. See page 27 for calculating peak flow.
2. Must maintain a pressure between 50 and 100 psi during peak day conditions and a velocity of less than or equal to 5 fps.
3. Must maintain a pressure above 25 psi during a fire flow event and a velocity not to exceed 10 fps.
4. The engineer shall provide flow calculations and any necessary computer models for the items listed above in order to provide documentation for the basis of design. The engineer shall provide a clear, understandable schematic of the system showing the junction nodes, pipes, etc., for any computer modeling. The engineer shall also provide input data which shows the pipe diameter, pipe lengths, system demands, pipe flows, AND output data that show pressures, velocities, head loss, and flow rates.

NOTE: *These design parameters supersede the minimum requirements in Chapter IV, Pipe Sizing for Distribution Mains, that states the prescribed minimum requirement of 12-inch mains in major (arterial) streets, 8-inch mains in collector streets, and 6-inch mains in local streets in case of conflict regarding design minimums.*

c. **Conformance with Master Plan**

The engineering report shall show that the proposed collection system conforms to the City's master plan for the area and the development's specific master plan if applicable, or as stipulated by the City.

d. **Environmental Issues**

The report shall address potential compliance issues with Clean Water Act Section 404, cultural resources, or any other environmental requirements.

e. **Signed/Sealed**

The design report shall be signed and sealed by an Arizona Registered Professional Civil Engineer. A full design report documenting the requirements above may not be required if a main is to be installed to meet City Code Section 37-33 or needs to be upsized in accordance with the Downtown Master plan. For these types of projects, a signed and sealed memo stating the purpose of the improvements may be adequate for the submittal requirements for plan review, as approved by WSD.

3. Checklists - Private Development and Capital Improvement Projects (CIP)

All technical and engineering plans relating to CIP and private developer projects subject to the development review process shall be submitted to PDD or WSD for review and approval. Refer to Chapter II to determine which department is responsible for the plan review.

For preparation of private development and CIP water/sewer main extensions that will become a part of the Phoenix system, refer to the checklists and guidelines available on PDD and WSD websites. For website links refer to **Appendix A**, pages A-2 and A-3.

4. Construction Plans and Technical Specifications - CIP Projects/Projects with City Financial Participation

a. **Design Plans**

For CIP projects and private development projects where the City participates financially, signed and sealed design plans shall conform to the requirements of the Maricopa County Environmental Health Code. The design plans (water, sewer, and reclaimed water) must be submitted to Maricopa County Environmental Services Department (MCESD) to receive the certificates of approval and verifications of general permit conformance. Approval from MCESD is required prior to City Approval.

b. **Technical Specifications**

Signed and sealed technical specifications shall accompany the design plans for the construction of water/sewer mains and all other appurtenances. The specifications shall include but not be limited to the following:

1. Specifications for the approved procedures of operation during construction.
2. All construction information not shown on the drawings that is necessary to inform the builder in detail of design requirements for the quality of materials, workmanship and fabrication of the project.
3. Technical specifications shall conform to the MAG and COP Supplements and Specifications.

c. **Identification Information**

The MCESD approval forms request the following identification information for the COP's Water and Sewer systems:

1. Potable water system # 0407-025.
2. Sewage Collection System Name: City of Phoenix.

3. Sewage Treatment Facility Name: 91st Avenue Wastewater Treatment Plant.

For additional information on MCESD go to the following link:

<http://www.maricopa.gov/ENVSVC/>

5. Record Drawings

Three sets of construction plans shall be submitted to the city inspector as record drawings. The record drawings shall be sealed and signed by an Arizona Registered Professional Civil Engineer. The record drawings shall meet the requirements of WSD policies P-68/69 for private development projects and policy P-85 for CIP projects. For CIP projects, a CD of the sealed record drawings is also required to be submitted to the City. For private development projects, electronic copies are desired, but not required.

WSD Policies P-68/69, and P-85 are available on WSD website. For website link refer to **Appendix A**, page A-2.

6. Water Asset Management Information

WSD utilizes a comprehensive asset management program to provide maintenance for all water assets, such as hydrants, valves, water service line tap, and others.

For private developments, wherein there is a transfer of assets to the Water Service Department that includes water main facilities, minimal asset information will need to be provided. **Table 13, Sample WAM Information**, shows a sample table that will need to be completed as part of the Record Drawings cover page. Information for items marked with an "X" on this table does not need to be provided. The cost per unit column is an estimated material cost and can be taken from the Planning and Development Department's Engineer's Cost Estimate form. As an alternative to adding this information on the cover sheet, the developer may create an Excel spreadsheet to be submitted with the Record Drawings.

Table 13. Sample WAM Information.

PHASE 1 - WATER QUANTITIES (ESTIMATED)	NUMBER	UNITS	Manufacture	Cost per unit	Model
8" DIP WATER PIPE	3325	LF			X
6" DIP WATER PIPE	1176	LF			X
8" VALVE BOX & COVER	10	EA			
6" VALVE BOX & COVER	4	EA	MUELLER		
6" FIRE HYDRANT ASSEMBLY	10	EA	AMERICAN DARLING		
1" WATER SERVICE WITH 3/4" METER	103	EA	X	X	X
1" LANDSCAPE WATER SERVICE WITH 3/4" METER	1	EA	X	X	X

For Capital Improvement Projects, the design process will need to be coordinated internally with the GIS & Asset Management Team to identify the assets that will need to be inventoried during construction. A detailed Asset Management spreadsheet will be created as part of the final design of the project. For some assets, GPS coordinates will need to be provided. This information must meet the requirements of WSD guide specification 01782 - RECORD DOCUMENTS.

E. WATER DEMAND AND SEWER DESIGN FLOWS

Included in this section are basic water demands and sewer flow criteria established by WSD. The minimum water main pipe sizes established in **Table 15, Minimum Water Main Sizing within COP Grid System** (found in Chapter IV, Section C), are not always adequate to meet water demands. For some projects, a detailed analysis of domestic and fire flow demands may be required to properly define requirements for system design.

1. Water and Sewer Design Flows

The following **Table 14, Water and Wastewater Design Flows** shall be used to calculate both water and sewer design flows utilized in the preparation of engineering design reports, plans, and specifications.

Table 14. Water and Wastewater Design Flows.

Land Use	Unit	Water Average Daily Flow/Unit (gal)	Wastewater Average Daily flow/Unit (gal)
Single Family Residential	Dwelling	360	240
Multi-family	Dwelling	240	180
Commercial (retail/mall)	1000 ft ²	125	75
Commercial (office)	1000 ft ²	115	90
Warehousing/Big Box Retail	1000 ft ²	30	25
Industrial	1000 ft ²	65	50
Schools	Student	25	20
Hotel (no restaurant)	Room	140	100
Hotel (with restaurant)	Room	200	150
Resort	Room	300	210
Hospital (all flows)	Bed	500	300
Landscape Water Requirements			
General Landscaping	Acre	4,374	N/A
Public Right of Way or Streetscape	Acre	1,339	N/A
Surface Water	Acre	5,335	N/A

NOTES: The following italicized notes are for Table 14, Water and Wastewater Design Flows

Complete design flows are not provided for **industrial and hospital facilities** because case-by-case evaluation is necessary due to varying water demands observed for these use types. Some industrial uses such as data warehouses, food processing, bottling plants, and semi-conductor manufacturing can use more than ten times as much water as compared to warehousing or dry assembly manufacturing with no cooling tower use. Water use in hospitals varies greatly depending upon cooling tower and boiler use, the extent to which the hospital is used as a research and teaching facility, the amount of out-patient versus in-patient services provided, and the types of equipment used. Estimates of anticipated water use and wastewater generation must be produced for each new development or major expansion using projections of demands taking into account the following types of categories:

- ***Water for cooling towers:*** Cooling towers use can make up more than fifty percent of water demand at industrial facilities having large refrigeration units or cooling of servers. In most cases, cooling towers use twenty to forty percent of the water requirements for industrial operations and hospitals.
- ***Water used as an input for production:*** In some manufacturing operations, water is used as an input in the manufacturing process and must be included in demand projections because of the large volumes used. Examples include ice-making, soft-drink or water bottling operations, and food manufacturing such as industrial bakeries.

- **Water used in production/activities:** In many manufacturing operations water is used for cooling, cleaning, or other operational activities and must be included in demand projections. Examples include metal forming and finishing, semi-conductor wafer production, and aerospace parts manufacturing. Processes employing newer technologies tend to use less water than older technologies, but estimates must be made on a location and process-specific basis. Some medical facilities are now using the newer medical imaging techniques and sterilization processes that use little or no water, while some medical equipment still requires significant amounts of water.
- **Bed to space ratios and mix of services:** Bed to space ratios and services provided in hospitals can vary greatly. These variations depend upon the proportion of space necessary to provide 24/7 nursing care, full linen service, and full food service to patients staying overnight. Furthermore, some hospitals are highly specialized and focus on particular types of treatment and/or research while others provide general and emergency services only. Water use on a per-square-foot or per-bed-basis can even vary significantly between different parts of hospitals, so large expansions will require an individual analysis.

2. Water Peak Flow

Peak Flow shall be calculated as 1.7 times the average daily flow.

NOTE: For clarification, the following example characterizes the calculations performed to determine the design flows and quantities involved in a hypothetical facility.

EXAMPLE: Hypothetical water demand/flow evaluation (not including fire flows).

ASSUME: A 1000 dwelling unit multi-family development.

CRITERIA: From **Table 14, Water and Wastewater Design Flows.**

Average daily flow = 240 gallons per unit per day (gpupd)

Average total daily flow = 1,000 x 240 = 240,000 gallons per day (GPD)

Peak daily flow = 240,000 GPD x 1.7 (peaking factor)

Peak daily flow = 408,000 GPD

A Hazen-Williams pipe roughness coefficient, C-value, of 120 shall be used for all pipe diameters and materials.

3. Sewer Peak Flow

All gravity sewer mains shall be designed for peak flow conditions. Peak flow is calculated as the product of the peaking factor and the average daily flow. The peaking factor should be calculated from Harmon's formula.

Design Flow = Peak Flow = Q Peak = Q avg [1+14/ (4+ P^{1/2})], Where P = Population/1,000

F. WATER AND SEWER MAIN ABANDONMENT METHODS

There are three approved methods of abandoning water and sewer mains in public ROW and easements:

- Total removal of pipe.
- Crush pipe in place by mechanical means. This cannot be applied to asbestos cement pipe.
- Leave pipe in place and fill with low strength grout.

No other methods are acceptable.

NOTE: If developers are stipulated to upsize or replace any existing water/sewer mains, existing water/sewer mains shall be abandoned pursuant to this section, and all the existing lateral water/sewer service connections shall be transferred to the new mains.

G. WATER AND SEWER STUBS OR TAPS AHEAD OF PAVING

This section only applies to water and sewer taps off new mains constructed by private developments. This section does not apply to water and sewer taps off existing mains. For water and sewer taps off existing mains, developments must acquire a City issued plumbing permit to request tap services, and all taps will be installed by the City according to City Code 37-42, 37-44, 28-27 and 28-32.

City of Phoenix does not allow new stubs or taps ahead of paving unless the property owner can provide a conceptual design report (e.g. Water/Wastewater Master Plans, Functional Segment Water /Wastewater Master Plans, etc.) and a preliminary site plan demonstrating the appropriate sizing and location of the mains or stubs for the specific parcel, usually at preliminary site plan approval stage. This applies to connections, such as water/sewer stubs, water/sewer mains, and service taps for fire lines and/or domestic use, to a proposed new main. The request for taps ahead of paving shall be approved by WSD, through technical appeal process.

If the City approves the request for taps ahead of paving, and the size or location of service taps (including sewer, domestic water, fire line and/or landscape connection taps) changes after the installation due to design changes, or for any other reason, it shall be the property owner's responsibility to remove and replace the entire tap to the correct size/location and remove any unused infrastructure at the property owner's expense.

H. CROSS CONNECTIONS AND BACKFLOW PREVENTION

1. Cross Connection

No physical connection shall be allowed between a potable and a non-potable water supply system. Any connection is considered a cross connection. In addition, there shall be no physical connections between a potable water supply system and a wastewater system which would permit the passage of any wastewater or polluted water into the potable supply.

2. Backflow Prevention

To protect the public water system, a backflow preventer shall be installed and located on private property outside of the right-of-way or public utility easement. All maintenance of the backflow preventer is the responsibility of the property owner. Specific provisions regarding cross connections and backflow prevention are available through PDD, Backflow Prevention Program. Also refer to the City of Phoenix Adopted Plumbing Code as well as City Code, Chapter 37, Article XII.

I. MAINTENANCE OF PLANT OPERATIONS (MOPO) PROCESS FOR CROSSING TRANSMISSION MAINS

1. Guidelines for Maintenance of Plant Operations (MOPO)

1. Introduction

The purpose of this section is to provide comprehensive guidelines for the preparation and implementation of a MOPO plan for the City of Phoenix's Water Services Department. Ensuring the continuous and safe operation of our water and wastewater system's services is paramount. This section outlines what a MOPO is, when it should be prepared, the essential information it must contain, and the appropriate stages during a project for its submission and review.

2. What is a MOPO?

A Maintenance of Plant Operations (MOPO) is a detailed plan designed to ensure that the essential functions of the City of Phoenix's water and wastewater systems continue uninterrupted during maintenance, construction, or any activities that could potentially disrupt normal operations. It outlines key activities, schedule of events, assets involved, and personnel, to serve as a proactive

approach to identify risks, outline mitigation strategies, and coordinate efforts among various stakeholders to maintain service reliability and compliance with regulatory standards.

3. What Projects Require an Approved MOPO?

A MOPO should be prepared in any situation where planned activities might impact the normal operations of the City's critical water or wastewater systems. The Water Services Department generally defines critical infrastructure within the right of way as large water transmission mains (24 inches in diameter or larger), large sewer trunk mains (24 inches in diameter or larger), sewer interceptor (large-diameter regional sewer mains that collect and convey flows from multiple sewer trunk mains into a treatment plant), and large sewer force mains (8 inches in diameter or larger). Private utility and development projects working near any of these critical water or wastewater systems are subject to the requirements of this section and may require a MOPO.

MOPOs for work within the City's water or wastewater treatment plants and remote facility sites require additional coordination and an in-depth understanding of the facility, including its operations, staff, and schedule—details not covered in this section. Engineers and contractors working on plant projects or remote facility sites should coordinate with their City of Phoenix project manager for Plant or remote facility site specific MOPO considerations and requirements.

A list of frequent water and sewer project activities encountered within the right of way that require an approved MOPO is found below:

- a. Example activities near water transmission (24 inches in diameter or larger) pipes that require a MOPO:
 1. Connecting to existing water transmission mains 24 inches in diameter or larger.
 2. Isolating any valves connected to or depressurizing 24 inches in diameter or larger water transmission main. This applies to in-line isolation valves, branch valves connected directly to a transmission pipe, or bypass assembly valves.
 3. Be aware that WSD must test any large transmission main valves to ensure proper isolation at least two weeks before any scheduled MOPO activities. Be sure to account for this additional timeframe when submitting a MOPO for review.
 4. Excavating or utility work near an existing water transmission main (24 inches in diameter or larger). See Figure below for illustrative conditions that require a MOPO. Please note the dimensions below are measured from the edge of proposed excavation/trench limits, not to the center or edge of a proposed utility.
 - The bottom of the proposed trench is within 4 feet of the crown of the water transmission main.
 - The horizontal distance from the edge of transmission main to edge of a proposed trench is less than 10 feet, or centerline of pipe is less than 2.5 times the diameter of the transmission main away from the edge of the trench. Whichever distance is greater shall govern.
 - A utility is crossing below transmission main (24 in diameter or larger) at any clearance.
 - Any trenchless construction methods (horizontal direction drilling, jack & bore, tunneling, etc.) crossing a transmission main below or above at any clearance. Horizontal direction drilling (HDD) and Jack & Bore must maintain minimum 3-ft clearance in Zone A.

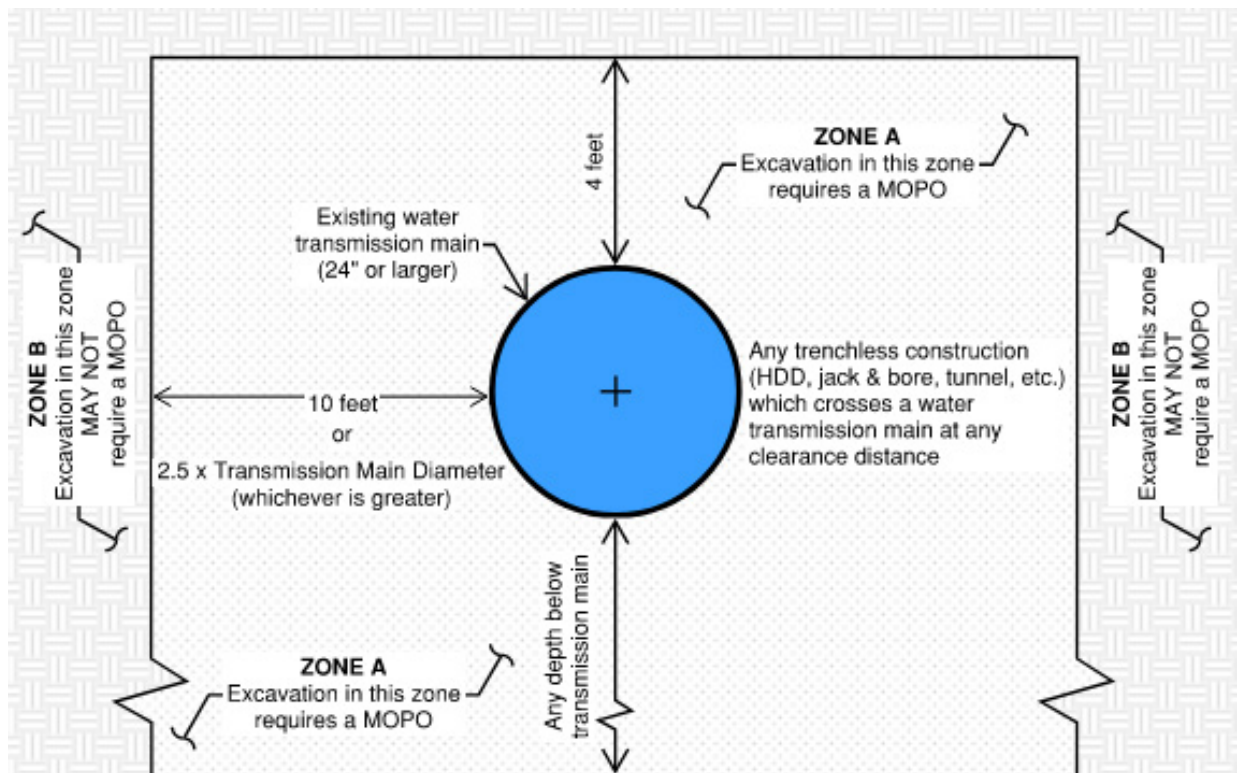

Figure 4. MOPO Requirements for Excavation Near a Water Transmission Main.

5. Shut down of existing impressed current cathodic protection rectifier units attached to 24 inches in diameter or larger transmission main.
 6. Interconnection sites and connection between City of Phoenix and an adjacent municipality (when allowed by an IGA) or private water company.
 7. Extra protection (MAG Standard Detail 404) on a water transmission main 24 inches in diameter or larger due to sewer, force main, storm drain, or non-potable waterline separation.
 - For sewer service pipes crossing a transmission main, please review the requirements in Section III.C for extra protection, horizontal & vertical separation requirements, and preferred alternatives.
 8. Any work or outage on an existing 24 inches in diameter or larger transmission main appurtenance (fire hydrant, ARV, access manway, etc.).
 - Note, this does not apply to City of Phoenix ARV or Fire Hydrant inspection program work.
 9. Geotechnical borings conducted within 10 feet of an existing water transmission pipe that is 24 inches in diameter or larger.
 10. Soil nails or other buried slope stability measures that extend into Zone A (as shown in Figure 4 above) near an existing water transmission pipe 24 inches in diameter or larger.
- b. Common activities near large sewer mains (24 inches in diameter or larger) and sewer force mains (8 inches in diameter or larger) that require a MOPO.
1. Isolating any valves or appurtenances (e.g., combination air valves) on a sewer force main 8 inches in diameter or larger.
 2. If bypass pumping is required on a sewer pipe of any size.

3. New sewer force mains 8 inches in diameter or larger which discharge into an existing gravity sewer manhole. Note, new force mains 6 inches in diameter or smaller into an existing manhole are covered by WSD Standard Detail S-511.
4. Extra protection (MAG Standard Detail 404) on a sewer main 24 inches in diameter or larger or a sewer force main 8 inches in diameter or larger due to water/sewer separation requirements.
5. Geotechnical borings conducted within 10 feet of an existing sewer main pipe that is 24 inches diameter or larger, or within 10 feet of a sewer force main that is 8 inches in diameter or larger.
6. Soil nails or other buried slope stability measures that extend into Zone A (as shown in Figure above) near an existing sewer main pipe with a diameter of 24 inches or larger, or near a sewer force main with a diameter of 8 inches or larger.
7. Excavating or utility work near existing large sewer mains (24 inches in diameter or larger) and sewer force main (8 inches in diameter or larger). See Figure below for illustrative conditions that require a MOPO. Please note the dimensions below are measured from the edge of proposed excavation/trench limits, not to the center or edge of a proposed utility.
 - The bottom of the proposed trench is within 4 feet of the crown of the sewer force main or sewer main.
 - The horizontal distance from the edge of force main/sewer main to edge of a proposed trench is less than 10 feet, or the distance from the center of force main/sewer main to the edge of a proposed trench is less than 2.5 times the diameter of the sewer force main/sewer main; whichever distance is greater shall govern.
 - A utility is crossing below a force main/sewer main at any clearance.
 - Any trenchless construction methods (horizontal direction drilling, jack & bore, tunneling, etc.) crossing a force main below or above at any clearance. HDD and Jack & Bore must maintain minimum 3-ft clearance in Zone A.

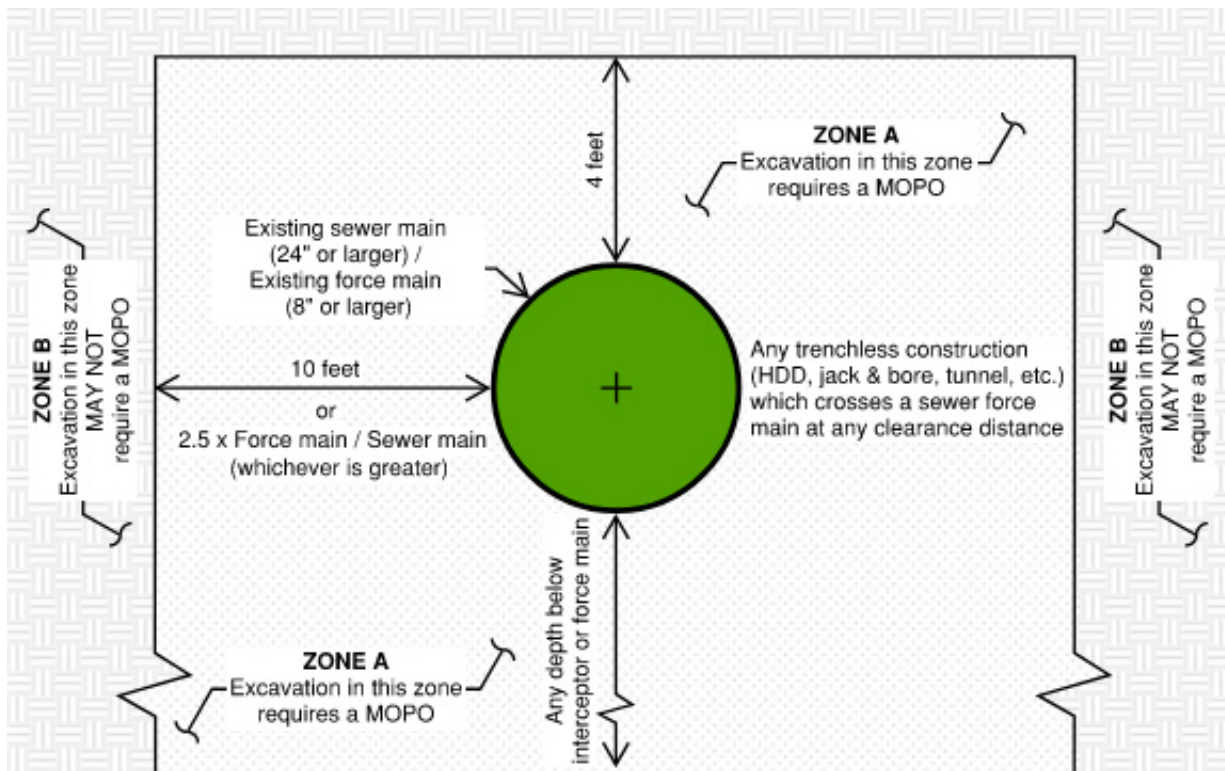

Figure 5. MOPO Requirements for Excavation Near a Sewer Force Main or Sewer Main

c. MOPO Requirements for Excavation Near a Sewer Force Main/sewer main.

- An approved bypass plan and all necessary equipment shall be present onsite whenever excavation activities fall below the minimum separation requirements.
- A comprehensive mitigation plan addressing potential Sanitary Sewer Overflows (SSOs) and pipe damage, along with specified replacement materials, is required.
- A detailed, photo-supported report for each individual crossing segment shall be provided.

4. What Information Must Be Included in a MOPO?

The list below summarizes the minimum information that must be included on a MOPO. Several example MOPO plans and exhibits are included in **Appendix G** at the end of this manual.

- a. Project name, project number, site name, and location.
- b. Date written, author, and revision number.
- c. Anticipated start date, end date, and total MOPO duration in days.
- d. A list of pre-MOPO activities and their schedule (e.g., temporarily close isolation valve #12345 and test for leaks).
- e. A list of MOPO activities and their schedule (e.g., isolate valve #12345 and lock out/tag out).
- f. A list of post-MOPO activities or additional items that may need to be addressed and their schedule.
- g. A list of emergency contacts for individuals associated with the MOPO including name, company, phone number, and role/title on the project. At a minimum this should include representatives from the City, Contractor, Engineer, and inspectors, but should may also include any subcontractors or specialty inspectors associated with the proposed work.
- h. An exhibit showing any applicable information such as: plan and profile of transmission main crossings or connections, bypass pumping manhole locations, isolation valve locations and numbers for transmission main shutdowns, etc.

- i. Completed utility pothole data. Note, this must be completed before a MOPO will be approved and cannot be part of the pre-MOPO activities. Utility pothole locations and elevations should be shown on the exhibit.
5. What Information Should Be Included on the Construction Drawings When a MOPO is Required?

For projects planning to do work which would require a MOPO, engineers must include the following general note on the construction drawings:

PORTIONS OF THE WORK NEAR OR CROSSING CITY OF PHOENIX WATER TRANSMISSION MAINS, SEWER MAINS, OR SEWER FORCE MAINS SHALL FOLLOW THE CITY OF PHOENIX WATER SERVICE DEPARTMENT (WSD) DESIGN STANDARDS MANUAL FOR WATER AND WASTEWATER SYSTEMS SECTION III.I AND BE COORDINATED WITH WSD.

6. When should a MOPO be submitted and How Should It Be Submitted?

Private development projects shall submit a draft copy of the MOPO to WSD.MOPO@Phoenix.gov. If the project has an assigned inspector from PDD, please copy them as well when submitting a MOPO for review. The City's CIP projects shall work with their City Project Manager or Liaison to submit the MOPO for review.

Draft MOPO plans should be submitted at least 4 weeks before any scheduled MOPO activities. However, since MOPO work depends on other ongoing projects within the City's water and wastewater systems, it's recommended to submit and schedule your MOPO as early as possible to avoid potential conflicts. Additionally, more complex shutdowns may require extra coordination or equipment testing beforehand, so these should also be submitted early to ensure enough time for review, coordination, and testing.

MOPO documents should be sent in the original Microsoft Excel format (xls or .xlsx), not as a PDF or any other document format. Please contact WSD.MOPO@Phoenix.gov or your City of Phoenix Project Manager for a template copy of the MOPO Excel spreadsheet.

After a draft copy of the MOPO has been submitted and reviewed, a coordination meeting may be scheduled to discuss work activities, potential restrictions, or schedule impacts before finalizing the MOPO. Once the MOPO has been approved, a confirmation email will be sent to the person who submitted it. This confirmation email must be received prior to commencing any MOPO-related work.

IV. WATER DISTRIBUTION AND TRANSMISSION SYSTEMS

A. WATER SYSTEM OVERVIEW - PRESSURE ZONES

Approximately 72 operating pressure zones serve the municipal water distribution system for the COP. These zones operate nominally within a static pressure range between 50 to 100 psi and provides a minimum of 40 psi at the customer's meter, in accordance with the City's Code. This 40 psi minimum applies only if the property elevation is within the pressure zone elevation range; otherwise, the developer/owner is required to install a private booster facility. With regards to typically high seasonal water demand variations among pressure zones with elevated storage, operating pressure fluctuations are normal. Information on pressure zones serving the various areas of the City can be obtained from the WSD. **Figure 5, Typical Major Pressure Zone Configuration**, schematically shows a major pressure zone representing elevated storage. Not all pressure zones include elevated storage. Therefore, individual development design requirements may vary.

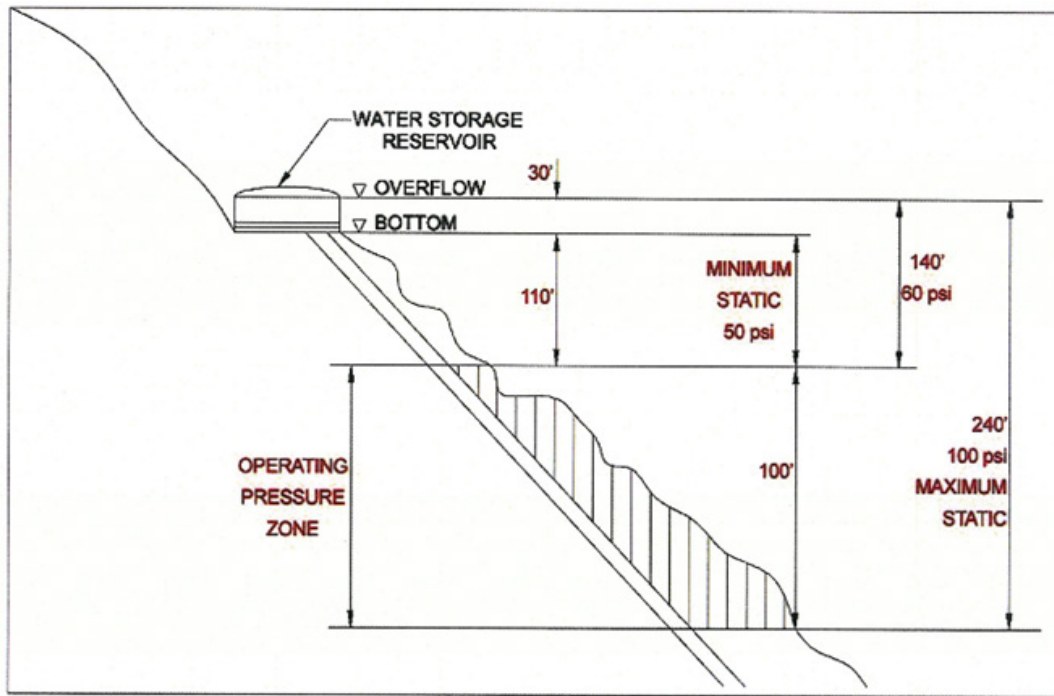

Figure 6. Typical Major Water Pressure Zone Configuration (rounded to the nearest 10 psi).

B. WATER MAIN DESIGN CRITERIA APPLICABLE TO BOTH DISTRIBUTION AND TRANSMISSION MAINS

1. Water Main Extensions

The water main extension policy of the COP is contained in Article II of Chapter 37 of the Phoenix City Code. As set forth in the Code, developers must pay all costs for constructing water mains necessary to afford adequate service during peak demands, including fire flow. Per section 37-33 water mains must be installed in all streets bounding an entire development regardless of whether it does or does not directly service the property being developed. Under certain circumstances, as described in Section 37-35 of the Code, repayment of the cost of “off-site” water mains (approach mains) may be available. For procedures on water repayments, refer to WSD Policy P-77, which is available on WSD’s website. For website link refer to **Appendix A**, page A-2.

2. Water Requirements for City Defined Areas (Master Plan)

Downtown Core Area: This area is defined as between 7th Street to 7th Avenue and Jackson Street to the I-10 Freeway. Refer to **Figure 7, Boundary Map for Downtown Core Area**, for the boundaries of the Downtown Master Plan. All new developments that occur within these boundaries require 12-inch water mains. Existing mains 6 inches in diameter and smaller are considered substandard within the Downtown Core Area and shall be replaced with 12-inch mains. Water mains that are 8 and 10 inches in diameter may remain in service if it can be demonstrated that they can adequately meet the project's total water needs, including fire flow. All substandard mains shall be abandoned, left in place, or removed as directed by WSD.

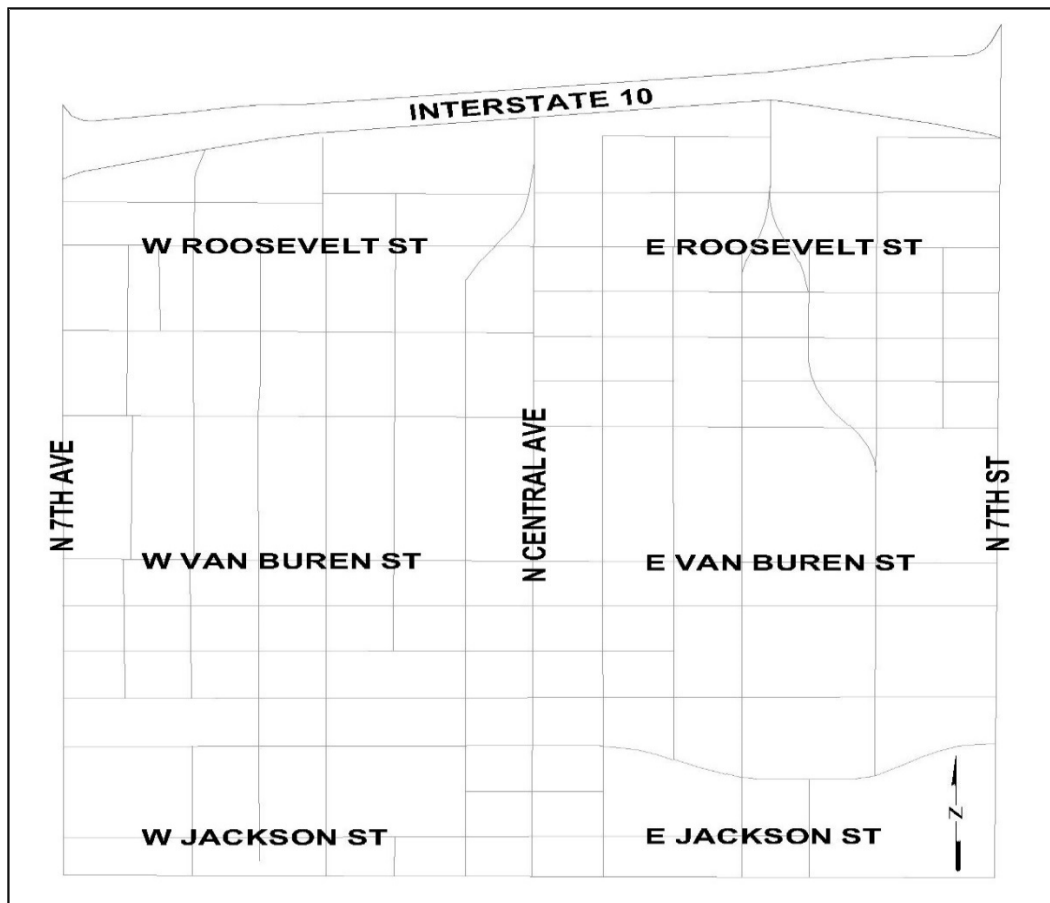

Figure 7. Boundary Map for Downtown Core Area.

EXCEPTION: Adaptive Reuse Developments

Adaptive reuse projects that are within the Downtown Core Area may not be required to upsize 6-inch substandard mains. The developer or design engineer shall demonstrate the existing main is capable of meeting the project's total water needs as categorized below:

- a. Domestic water demand.
- b. Fire flow requirements.
- c. Fire sprinkler suppression system demand (if needed).

3. Water Main Classifications

For the purposes of this manual, all water mains in the COP system that are 16 inches and larger in diameter are classified as transmission mains. All water mains 12 inches and smaller in diameter are classified as distribution mains.

Exception:

Occasionally water mains 16 inches in diameter can be either type depending on the design application. In some cases, development water demands including fire flow may exceed the minimum pipe sizes outlined in Chapter 37 of the Code. In the cases where the existing grid is not capable of providing adequate source water, a larger 16-inch main may be stipulated and then configured as a distribution main. WSD will make this determination.

4. Water Main Design

Generally, water main design shall be based on peak flow plus fire flow demands (not to exceed 3,000 gpm). In some circumstances, WSD may determine that larger or smaller water mains are required. Water mains shall be designed to maintain a pressure greater than or equal to 25 psi at a point of maximum fire draft, at a velocity of less than or equal to 10 fps. Furthermore, water mains shall be designed to maintain between 50 to 100 psi during peak flow at a flow velocity of less than or equal to 5 fps.

5. Fire Flow Demand

For fire flow demands, please refer to the current adopted City of Phoenix Fire Code. If the Fire Department requires more than 3,000 gpm, the engineer shall design the water system to minimize water age.

6. Hydraulic Requirements

WSD may require a hydraulic modeling analysis for a project to evaluate and properly develop the available water source.

NOTE: Modeling may identify a requirement for a booster station, pressure-reducing facility, etc. WSD will make this determination.

7. Thrust Restraint for Distribution Mains

Joint restraint shall be used at all bends and fittings or where joint restraint devices are specified by the approved construction plan. Refer to MAG Standard Detail 303 and the COP Supplement Specifications 610 and 750.3.

Thrust blocks are not allowed in place of approved restrained joint systems. Thrust blocks can be used in addition to the approved restrained joint systems where a specific COP Supplement Detail calls out for thrust blocking, such as current COP Supplement Details P-1343, P-1351, and P-1360, or when otherwise approved by WSD through the Technical Appeal process.

The following MAG Details are specifically **not** approved:

- 302-1 Joint Restraint with Tie Rods
- 302-2 Joint Restraint with Tie Rods- Anchor Blocks

8. Corrosion Protection and Cathodic Protection

All ductile iron pipe (DIP) mains shall be protected from exterior corrosion. This protection shall consist of encasement in a polyethylene protective wrapping or other approved methods. Refer to COP Supplement Specification 750.2 and MAG Specifications Section 610.6.2 and 620.6.3.

For distribution and transmission mains 16 inches and larger, the need for cathodic protection and pipe material selection shall be evaluated and designed based on the City of Phoenix document, "Requirements for Corrosion Protection Design Standards Development Report for Large Diameter Ductile Iron, Steel, CCP and RCP Water Transmission Pipelines" found in **Appendix D**.

For more information on corrosivity charts, refer to the American Water Works Association.

9. Shop Drawings

For pipe and appurtenances larger than 12 inches, shop drawings and technical data are required for approval. After engineer's review and recommendation, shop drawings shall be submitted to WSD for review and approval. A minimum of three copies of each shop drawing and product data shall be provided.

C. ADDITIONAL DESIGN CRITERIA ONLY APPLICABLE TO DISTRIBUTION MAINS

Distribution mains are 6, 8, or 12 inches in diameter. As described in Chapter IV, Section B, 16-inch mains are occasionally considered distribution mains. No other pipe sizes are allowed to be constructed within the Phoenix water distribution grid. Project designs shall make every effort to loop water mains throughout the development to limit dead ends.

1. Acceptable Pipe Materials

Distribution mains 6 through 16 inches in diameter shall be ductile iron pipe (DIP). The pipe shall conform to the MAG and COP Supplements and Specifications.

2. Pipe Sizing for Distribution Mains

The design engineer shall size all distribution system pipes and appurtenances in accordance with the provisions of this manual. Additionally, City Code 37-33(A) establishes a minimum water distribution master grid system for residential type development as indicated by **Table 15, Minimum Water Main Sizing within COP Distribution Grid System**. For all other types of development, water mains are sized to meet fire flow requirements or approved master plans, whichever is greater.

NOTE: For all developments, with the exception of a single-family residence on a single lot, mains 4 inches or smaller within the streets bounding the entire development shall be removed and replaced pursuant to PCC 37-33.

Table 15. Minimum Water Main Sizing within COP Grid Distribution System.

Location	Pipe Size (inches)
Section line streets or grid arterials	12
Mid-section line streets or mid-grid feeders	8
All other streets (see exceptions below)	6
Downtown Core Area **	12

The following four bullet points refer to Table 15, Minimum Water Main Sizing within COP Grid System

Refer to **Figure 7 for the Boundary Map for Downtown Core area.

- Distribution mains that are single-feed (dead-end) systems and include fire hydrants shall be at least 8 inches in diameter.
- A 6-inch diameter distribution main configured as a system with two feeds (a looped system) can serve up to six fire hydrants. Additional hydrants can be served if the design provides for more feed points. A design analysis may be required by WSD for acceptance of such a system.
- This is a generalized pipe size guideline, which is subject to refinement in design analysis.

3. Distribution Main Cover

In accordance with MAG Specification 610, all distribution mains in major (arterial) streets shall have a minimum cover of 4 feet over the top of the pipe from finished grade. Distribution mains in other locations shall have a minimum cover over the top of the pipe as follows:

- a. Three (3) feet for distribution mains smaller than 12 inches in diameter, unless located in an easement or major (arterial) street, where 4 feet will be the minimum required.
- b. Four (4) feet for distribution mains 12 to 16 inches in diameter.

- c. Water mains constructed in washes and floodways shall have their crowns at least 2 feet below the 100-year storm scour depth and shall be constructed with restrained DIP. The restrained DIP shall extend a minimum of 10 feet on each side of the 100-year storm scouring.
- d. If finished grade cannot be identified, increased depth may be required.

4. Line Valves

Table 16, Valve Spacing, shows the maximum spacing for line valves on distribution mains.

Table 16. Valve Spacing.

Land Use	Maximum Valve Spacing (feet)
Residential	800
Commercial and Industrial	600

In residential developments, valves shall be located so that a maximum of 30 single-family dwelling units or a maximum of five valves are involved in a waterline shutdown. Additional valves may be required at tapping sleeves, valves, and/or tee intersections.

- a. A valve shall be located on each side of a canal, wash, railroad, and freeway crossing.
- b. Valves shall not be located in curbs, sidewalks, driveways, and valley gutters.
- c. All valves shall conform to MAG Specification 610.6 and 630, including the COP Supplements thereto.
- d. Valves shall be located at the point of curvature (PC) or point of tangency (PT) of the curb return at street intersections and aligned with a property or lot line in mid-block.
- e. Valve boxes and covers shall be provided for all valves.
- f. An additional line valve shall be installed on dead-end lines, exclusive of mains that dead-end in a cul-de-sac, within 20 feet of the end of pipe to remove the necessity of shutting down residences and businesses should the main be extended in the future.

5. Service Connections (Taps) and Meters on Distribution Water Mains

a. New Mains

Where new mains are being installed by a developer, service connections and meter boxes/vaults will be installed by the developer's contractor.

b. Existing Mains

All new service connections on an existing City water main shall be installed by WSD after all fees have been paid. Contact PDD at 602-262-6551 for more information.

1. When multiple distribution mains in the same pressure zone are adjacent to a development, all service connections shall be taken from the largest diameter main or as approved by WSD.
2. The service connections shall be limited in size to 50% of the service main diameter. On looped mains, there shall be a limited number of service connections comparable to the equivalent existing main capacity. On a dead-end main, service connections shall be limited to half that of the looped main. A new water main extension may be required when it has been determined that the existing main capacity has been exceeded.

Substandard Mains - (mains smaller than 6 inches in diameter) new service connections will only be allowed for a single-family residence on a single lot. Adequate Fire Protection

may not be available due to the size of the main and submitting a Non-Fire Service Acknowledgement form may be required prior to purchasing the service. Contact a Fire Protection Engineer with the Planning and Development Department to determine fire protection requirements for a single-family residence.

3. When service connections are allowed to be made from a Reinforced Concrete Pipe or a Concrete Cylinder Pipe distribution main, those connections will be in accordance with the guidance document "Procedure for Water Tapping Services into Reinforced Concrete Pipe (RCP) or Concrete Cylinder Pipe (CCP)" found in **Appendix E**.

c. Service Connection Requirements

1. Meter Boxes / Vaults - All meters shall be installed in a meter box or vault. The box or vault shall be located within the public ROW, water easement, or PUE. In addition, each meter must be located out of a driveway, paved area, or sidewalk. If a meter box must be located in a paved area, a traffic-rated meter box and separation pavers or expansion joints shall be required around the box. The meter shall be installed in accordance with COP Supplement Detail P-1363. 3 inch and larger meters require a meter vault per Detail W-500 on WSD’s website. For the website link, refer to **Appendix A**, page A-2.
2. Pipe Material - Materials and installation for service lines from the main to the meter shall conform to MAG Specification 631 and the COP Supplement 610. All service lines for meters 3 inches and larger shall be DIP. Service lines for meters less than 3 inches shall be Type K copper tubing.
3. Domestic Meter Service Connection Size - All new domestic meter service connections (taps) on existing or new mains for buildings including all single-family residential lots shall be a minimum of 1-inch in size.

For existing domestic meter service connections (taps) of 1.5, 2, and 4 inches in diameter, meter size may be reduced one size with a reducer. For all other existing domestic meter service connections (taps), the meter size shall match the tap size and reducers on taps are not allowed. See **Table 17** below for more detail.

For new domestic meter service connections (taps), installation of reducers is not allowed. All tap sizes must match the meter sizes. The only exception for new domestic connection requirements is that for new 3-inch meters, a 4-inch tap may be provided with a reducer with WSD’s approval. See **Table 17** below for more detail.

Table 17. Domestic Meter Sizes.

Domestic Meter Service Connection (Tap) Size	Domestic Meter Size
1-inch	1-inch meter. No reducer is allowed.
1.5-inch	New accounts: <ul style="list-style-type: none"> • 1.5-inch meter. • Existing accounts: <ul style="list-style-type: none"> • 1.5-inch meter, or, • 1-inch meter with a reducer.
2-inch	New accounts: <ul style="list-style-type: none"> • 2-inch meter. Existing accounts: <ul style="list-style-type: none"> • 2-inch meter, or, • 1.5-inch meter with a reducer.
3-inch	<ul style="list-style-type: none"> • 3-inch meter. No reducer is allowed.
4-inch or larger	<ul style="list-style-type: none"> • 4-inch meter, or, • 3-inch meter with a reducer if approved by WSD.
6-inch or larger	Meter must be the same size as the tap size. No reducer is allowed.

Note:

When a house remodel triggers a Plumbing Code Review, existing residential accounts with a 3/4 inch service tap and a 5/8 inch meter may upgrade the meter to a 3/4 inch meter while retaining the existing 3/4 inch tap, provided a 3/4-inch meter is deemed adequate per the City’s Plumbing Code.

4. Spacing and Cover - A minimum 5 feet of separation is required between water service connections. Meter service connections shall maintain a 30-inch minimum cover per COP Supplement Detail P-1342.
5. A minimum 5 feet of separation is required between the water service connections and fire and/or valve laterals. Refer to DSM Section IV.G.3.
6. A minimum 2 feet of separation is required between the water service connections and any bell and/or fittings.
7. Static Water Pressure - Where local static water pressure exceeds 80 psi or as per the COP Plumbing Code, a private pressure regulating or reducing valve shall be required on the customer side of the service meter.
8. Separate Service for Each Demand - A combination of fire, domestic and landscape meters is prohibited. Each demand requires a separate service connection. A combination of domestic and landscape meter is allowed except for landscape areas noted in section d.3. below. A combination of a fire line and domestic service cannot be combined except for single family residential homes on single lot (excluding subdivisions) as approved by WSD or qualified Adaptive Reuse projects as outlined in TRT00518.
9. Backflow Preventer - A backflow prevention assembly may be required. Refer to Chapter III for more backflow prevention information.
10. Domestic Meter Service Connection Location – A domestic meter service connection goes up to the end of right-of-way and ends at property line.
11. Service Connections shall be installed perpendicular to the water main within the right of way or easement. Refer to DSM Section IV.C.5.c.3 for meter size and corresponding meter service connection (tap) size.
12. Domestic Service Connection for Accessory Dwelling Unit (ADU) and Middle Housing Unit - All units shall fall under the following billing code for multiple dwelling units on a single lot:
 - ADUs – Type User 20
 - Duplex – Type User 10
 - Two Family Residences – Type User 20
 - Triplexes – Type User 21
 - Fourplexes – Type User 26
 - Townhouses – Type User 26
 - Three Family Residence – Type User 30

All above user types are required to have one combined (domestic water, landscape and fire) meter service connection to the City's water system. Separate water connection service for fire lines may be allowed through technical appeal process.

Customers shall provide ADU/Middle Housing Unit related plans and submittals to PDD for site, civil, fire and building code review and approval, as required by the City. The sizing of the meter connections shall meet the minimum requirements of the City Code, building code, fire code, and this design standard manual.

d. Type of Uses

1. Master Meters - A single service line and a master meter can be used as described below:
 - Two or more (Attached and/or Unattached) buildings located on the same lot (e.g., duplex, triplex, multi-family, manufactured home communities, or similar projects covering one lot).

- For single-family residential attached (hybrid type developments) that do not comply with the City's Private Accessway and/or right-of-way requirements.
 - Developments using master meters must have a separate fire line connection, and no more than 2 meters can be manifolded. If the property owner wants to use sub-meters beyond the city meter, they will remain as private and shall be the responsibility of the developer/property owner.
2. Mixed Use Developments - (residential and commercial) require a separate meter and separate onsite plumbing for each type of use. Refer to WSD Procedure P-106 for additional information.
 3. Landscape - A separate landscape irrigation tap and meter is required for landscape watering of all landscaped areas over 10,000 square feet, or for all water features having a daily consumptive use 1,000 gallons or more per day (PCC Section 37-53(B)). For commercial developments, it is recommended to consider a separate landscape meter beyond those required by City Code to reduce Development Occupational Fees (DOF) and wastewater treatment fee that can result from having a combined meter.
 4. Golf Courses/Lakes - Water meters servicing golf courses, lakes or any other continuous maximum flow uses terminating at atmospheric pressure, require special approval from WSD. These installations require a flow control valve and/or a flow restriction device and may be limited to the use of reclaimed water.
 5. Auto Court Cluster (Cluster) - In a Cluster development (a development with maximum six (6) detached single-family lots with only one point of access), the meter boxes and service lines do not front a water main due to shared or common access drive between single-family detached lots. The meter boxes and service lines shall comply with the following:
 - a. Must be located in common tracts deeded to the Homeowner's Association (HOA) for common purposes from the meter until such point as the service enters an individual lot. Water service lines shall not be permitted to cross adjacent lots, even if a Public Utility Easement exists on that lot.
 - b. The CC&Rs shall require the HOA to be responsible for the maintenance and repair beyond the meter.
 - c. The service line shall have a minimum horizontal separation of 5 feet at the connection to the main. Water service lines shall be installed ensuring they do not cross each other.
 - d. Water service lines in common tracts shall have an identifier indicating which lot it serves. The identifier shall be located at the meter and every 10 feet of pipe along the service alignment. The service line shall be constructed per the City of Phoenix Plumbing Code.
 - e. To minimize congestion, equal numbers of water meters should be placed on each side of a shared driveway.

NOTE: *Additional provisions for service connections and meters are contained in Article III and Article IV, Chapter 37 of the PCC.*

6. Water Meters and Sizing Guidelines

Water meters shall be sized in accordance with the **Table 18** below. The columns list the maximum allowable gallons per minute (gpm) allowed for any given meter size and type. Project designs which exceed the listed gpm unit values shall be upsized to the next larger meter.

Table 18. Water Meters and Sizing Guidelines.

Domestic Meters	
Meter Size	Maximum Allowable Flow Rate (gpm)
1"	50
1-1/2"	100
2"	160
3"	320
4"	500
6"	1,000
8"	1,600
10"	3,000
12"	5,000

Fire Line Meters	
2"	97
3"	220
4"	391
6"	881
8"	1,566
10"	2,447
12"	3,524

Notes:

- (1) – 10 and 12-inch domestic meters require a technical appeal to WSD.
- (2) - Fire line velocity is not allowed to exceed 10 ft/sec.
- (3) - Reducers on 1.5 and 2-inch taps may be allowed for existing domestic meters as outlined in IV.C.5.c.3.
- (4) - Reducers on 4-inch taps may be allowed for 3-inch meters if approved by WSD.
- (5) - Reducers on taps are not allowed for all other new or existing domestic meters.
- (6) - Reducers on taps are not allowed for all fire meters.

D. ADDITIONAL DESIGN CRITERIA ONLY APPLICABLE TO TRANSMISSION MAINS

1. Acceptable Pipe Materials

Transmission mains up to 24 inches in diameter shall be DIP. Transmission mains over 24 inches through 42 inches in diameter, regardless of location, shall be DIP, CCP, or steel cylinder pipe. Mains 48 inches in diameter and larger shall be DIP or steel cylinder pipe. The pipe shall conform to the applicable MAG Specifications and the COP Supplements thereto.

NOTE: *Service connections will not be allowed on transmission mains.*

2. Pipe Sizing

Transmission mains shall be sized to carry the designed peak flow required including fire flow without exceeding the velocities or head losses shown on **Table 19, Allowable Velocity and Headlosses**, which shows specific requirements for transmission mains.

Table 19. Allowable Velocity and Headlosses.

Pipe Size (inches)	Maximum Allowable Velocity (fps)	Maximum Allowable Headloss (ft/1000 ft)
16	5	6.06
20	5	4.66
24 and larger	5	Varies*

**To be determined by WSD*

NOTE: The above table is based on a Hazen-Williams pipe roughness coefficient of $C = 120$.

3. Transmission Main Cover

Minimum cover from finished grade to the top of the exterior surface of the pipe shall be 6.5 feet for 16-inch water mains and larger. Water mains constructed in washes and floodways shall have their crowns at least 2 feet below the 100-year storm scour depth and shall be constructed with restrained DIP. The restrained DIP shall extend a minimum of 10 feet on each side of the 100-year storm scouring. If finished grade cannot be identified, increased depth may be required.

4. Line Valves

Table 20, Line Valve Spacing, shows the maximum spacing for line valves on transmission mains.

An isolation valve shall be placed at the main between the water main and each fire hydrant, and a second maintenance valve at the fire hydrant when installed on a transmission main.

Table 20. Line Valve Spacing.

Pipe Size (inches)	Maximum Spacing (feet)
16 to 30	2,640
Greater than 30	5,280

All valves shall conform to MAG Specifications 610, COP Supplements 610 and 630. Also refer to COP Supplement Detail P-1391.

Line valves on transmission mains up to 36 inches may be gate valves or butterfly valves. A typical valve installation is shown in WSD's Large Pipe Details. For a copy of the typical valve installation details, contact WSD.

Line valves on transmission mains shall be installed a minimum of 150 feet away from any intersection to keep maintenance crews out of traffic.

If WSD requires the installation of electronic monitoring and remote operation equipment, the line valve shall be a butterfly valve with a rectangular vault, housing the valve operator and telemetry equipment. Each installation will require individual details. The design engineer shall check with WSD on acceptable equipment and the specific design requirements.

5. Restraint Systems

All bends, fittings, line valves, and bulkheads shall be restrained by using a joint restraint system compatible with the type of pipe. WSD will review all restraint systems prior to approval. The length of the restraint system shall be shown on the construction plans, and complete supporting data on the restraint system

design shall be submitted to WSD for review and approval. Concrete thrust blocks will not be accepted in lieu of restrained joints, but may be used in conjunction with restrained joint systems as approved or required by WSD.

6. Corrosion Protection

Where indicated by soil testing or as directed by WSD, mains shall be protected from exterior corrosion. This protection may consist of encasement in a polyethylene protective wrapping or other approved methods. Refer to the American Water Works Association Corrosivity charts and DSM **Appendix D** for more information.

7. Side Outlets

Flanged side outlets are provided to integrate parallel or crossing distribution lines. A minimum 12-inch flanged side outlet with a flanged side valve shall be provided at 1,320-foot intervals along the alignment. When connecting a transmission main to a distribution main, a maintenance valve at the connection to the distribution main shall be installed in addition to the flanged side valve from the transmission main. Prior to approval, WSD must review the location of outlets and tie-in connections to any existing or proposed facility, including the bulkheads at the end of transmission mains.

8. Bypass Assemblies

Bypass assemblies shall be provided at valves on transmission mains 16 inches and larger in diameter. A typical assembly is shown schematically in WSD's Large Pipe Details. For a copy of the bypass assembly detail, contact WSD.

Bypass assemblies shall be installed a minimum of 150 feet away from any intersection to keep maintenance crews out of traffic.

Transmission mains between valves shall be treated as an independent unit with provisions for dewatering, filling, removing air, and adding air as appropriate for the transmission main construction and maintenance. A bottom tangent flanged outlet shall be provided at all profile low points and a top tangent flanged outlet shall be provided at all profile high points in all transmission mains.

9. Air/Vacuum Valve Assemblies

All air/vacuum valve assemblies for transmission mains require individual approval by WSD. Air/vacuum relief valve assemblies shall be installed at high points in the transmission main at locations approved by WSD. Air/Vacuum valve assemblies are to be used only when it is determined that a fire hydrant is not appropriate. Air/vacuum valve assemblies are shown in WSD's Large Pipe Details. For a copy of these details, please visit [Water/Sewer Engineering Details | City of Phoenix](#)

10. Access Outlets for 42-inch Mains and Larger

Access outlet with manhole as shown in WSD's Large Pipe Details shall be installed on 42-inch and larger transmission mains on each side of a line valve and shall not exceed 2,600 feet unless otherwise approved by WSD through the Technical Appeal process. For a copy of the access outlet detail, contact WSD.

11. Use of Fire Hydrants and Placement

In water mains 16 inches and larger a fire hydrant shall be placed at the high point and/or low point of the profile to permit air release, de-watering and maintenance purposes when applicable. The bonnets on these hydrants are to be painted black.

12. Testing and Final Acceptance

The construction project is functional only after demonstrating the completion of pressure testing, bacteriological testing, and final inspections. Then an acceptable flushing schedule and chlorine residual monitoring plan shall be prepared by the design engineer to maintain and demonstrate an acceptable level of turnover during the early period of new project operation. Upon substantial completion, the start-up and commissioning period is ready to begin. The start-up details and duration of commissioning shall be identified early on and listed in the project scope of work by the design engineer.

13. Crossing of Transmission Mains

Whenever a utility crosses perpendicular over or under a transmission main, a minimum of 2-foot vertical clearance as measured from the outside of the pipe to the outside of the crossing utility, must be maintained. When crossing transmission mains, a shutdown and de-energizing, following WSD procedure and with WSD approval, may be required. Refer to DSM Section III.I.

14. General Requirements for Working Around Prestressed Concrete Cylinder Pipe, Concrete Cylinder Pipe and Bar Wrapped Concrete Pipe

NOTE: This section provides general requirements for work performed around Prestressed Concrete Cylinder Pipe (PCCP). These requirements also apply to Concrete Cylinder Pipe (CCP) and Bar-Wrapped Concrete Pipe (BWCP). All references and notes within this section shall be modified as necessary to reflect the specific pipe material being used on the project.

General Requirements

Prestressed concrete cylinder pipe (PCCP) is custom designed for installation and service conditions specific to each project. The overall goals in working around PCCP are to maintain the integrity of the original trench, limit construction equipment passing over the pipe, and consider integrity of the pipe during nearby construction to protect the pipe and provide a safe work area around the pipe.

For projects planning to cross or work parallel to PCCP, the Engineer shall add a general note to the plans:

PORTIONS OF THE WORK NEAR OR CROSSING PCCP SHALL FOLLOW THE CITY OF PHOENIX WATER SERVICES DEPARTMENT (WSD) DESIGN STANDARDS MANUAL FOR WATER AND WASTEWATER SYSTEMS (SECTIONS APPLICABLE TO PCCP AND TRANSMISSION MAINS) AND BE COORDINATED WITH WSD.

PCCP receives support from the soil around it. For PCCP remaining in service while work occurs nearby, no excavation shall be allowed adjacent or parallel to the PCCP within a distance of 2.5 times the diameter of the PCCP (see **Figure 8, Excavation Near PCCP**) unless the depth of said excavation is above the crown of the existing PCCP. A minimum of 2 feet of cover shall remain at all times.

Variances for Pipe Depressurized During Construction

This section describes variances to the General Requirements above if PCCP is removed from service and depressurized during construction. If a vertical trench with a shoring system is used, a 5-foot minimum clearance shall be maintained between the outside of the pipe and edge of trench. Sloped excavations near depressurized PCCP also require a 5-foot minimum clearance between pipe and edge of trench.

Other Variances

Variances from the above requirements may be considered. Any such variances must be requested by the Contractor and approved by the Water Services Department prior to any excavations. A qualified pipe engineer must evaluate the specific conditions and variance to determine if the work can be completed as proposed by the Contractor safely and without damaging the pipe or existing trench.

Construction Equipment and Methods

Pothole PCCP using soft dig or vacuum methods prior to excavation to determine the depth and location of the pipe in excavation area. Other methods, such as ground penetrating radar may also be used.

Modifying the loading on the pipe by addition or removal of cover or heavy equipment loading (cranes, large excavators, scrapers, etc.) over the pipe may change the loading and compromise the pipe integrity. Use of non-highway vehicles over the pipe requires engineer design review and load calculations to be provided to the City WSD for approval. Do not add additional earth loads (embankment, fill, spoils, etc.) above the pipe because this may overburden the pipe, particularly in non-paved areas. If possible, the pipe alignment should be roped off to prevent access to the construction zone area.

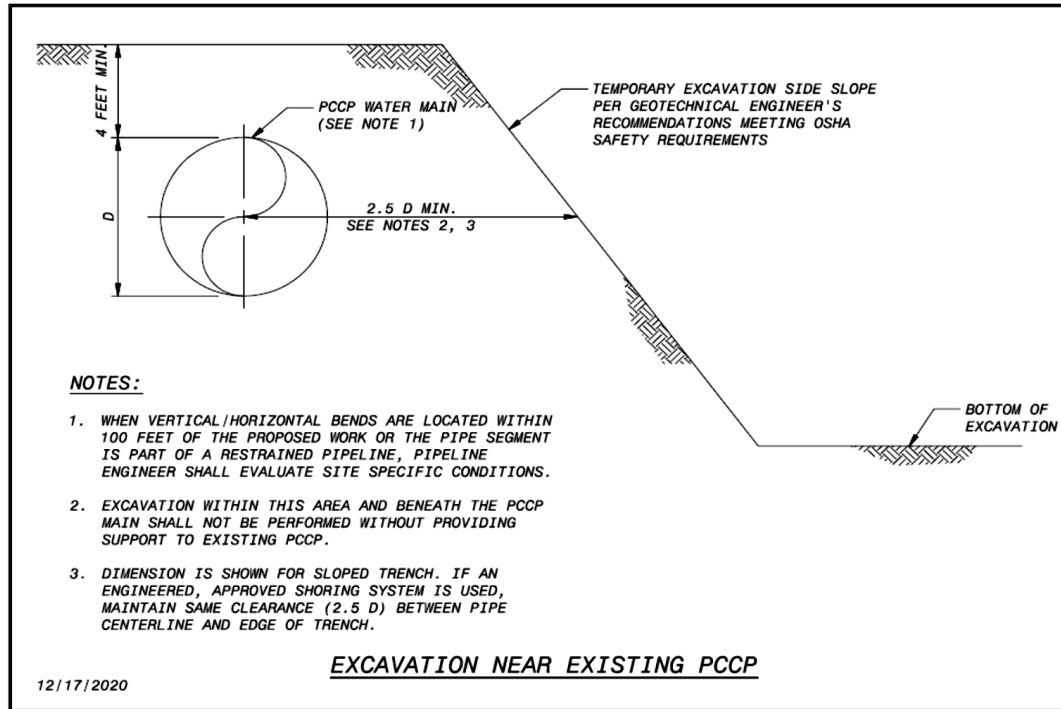

Figure 8. Excavations Near PCCP.

Whenever construction equipment is passing over the PCCP, 4 feet of undisturbed soil is required to remain in place above the pipe at all times to help distribute live loads to the area around the existing pipe and minimize equipment/traffic loading on the existing pipe. If excavation is allowed near the pipe, extreme care shall be taken in both the excavation to prevent damage to the pipe and placement of equipment to not overburden the pipe.

Considerations if PCCP is Exposed During Construction

PCCP exposed during construction must be removed from service and depressurized. If removal of backfill or bedding surrounding PCCP is allowed, nylon strap support system with I-beam structural support spanning the excavation is required to support the spanning PCCP pipe. The support system shall be designed by an engineer based on the specific requirements of the pipe and excavation. The engineer must also evaluate whether the pipe must be fully dewatered while the pipe is excavated. If possible, the pipe joints should not be part of the spanning/unsupported section of pipe. A survey of the pipe crown on either side of the excavation must be completed by the contractor with the City's inspector on-site before removing bedding and prior to placing backfill around pipe to ensure deflection of pipe did not occur during construction. See **Figure 9, Conceptual Detail for Structural Support of Existing PCCP**, for a conceptual schematic.

The contractor should not make contact with the pipe with machinery (rollers, excavating buckets, heavy equipment, compactors, etc.). Excavation within 1 foot of the pipe shall be completed by hand digging using hand tools (shovel, pick, crowbar, etc.) to expose the crown and outside diameter of pipe. The contractor shall notify the City if mortar coating is scraped, chipped, or otherwise damaged during construction.

Backfill of any structures or pipe below the PCCP should be completed using controlled low-strength material (CLSM)/flowable fill to ensure proper compacting and minimize settling of PCCP. PCCP should also be backfilled with CLSM from the bottom of the excavation to at least the 3 and 9 o'clock positions (spring line) of pipe, but preferably to the crown of pipe.

Backfill over the top of PCCP shall be engineered fill, compacted with jumping jacks compactors in lifts that are acceptable for the material and conditions of the backfill. If larger equipment is requested for compaction of backfill over the top of pipe, Contractor must provide equipment information and justification for use to WSD.

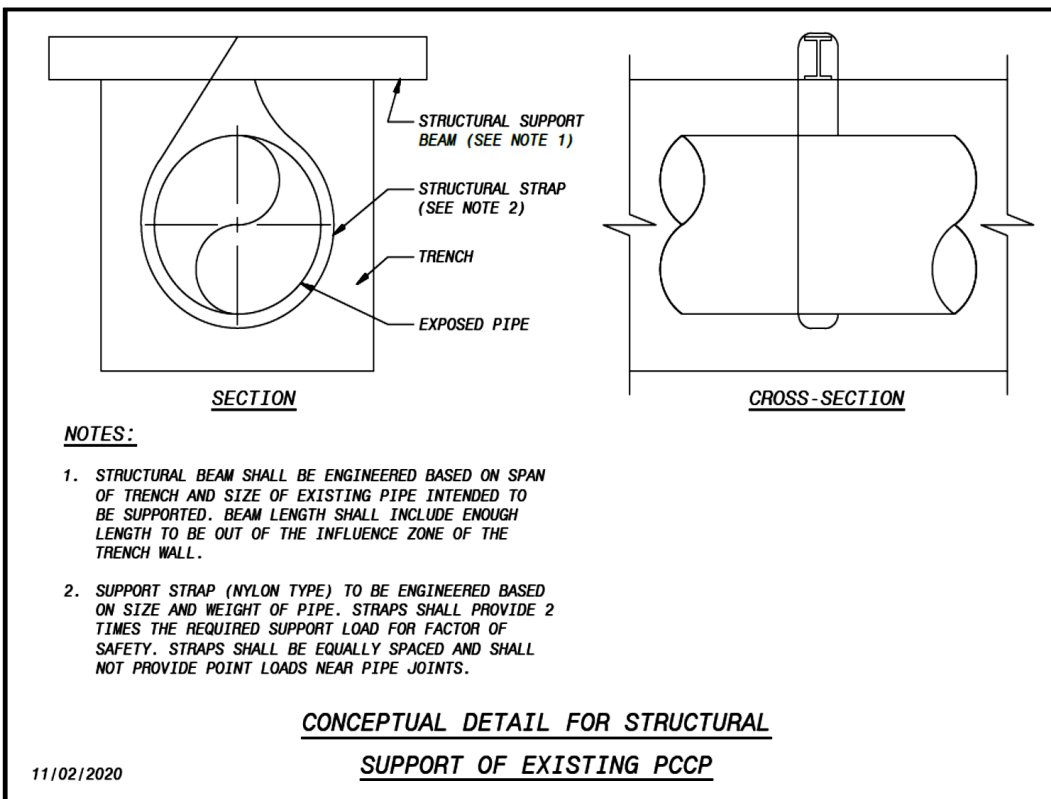

Figure 9. Conceptual Detail for Structural Support of PCCP.

Drilling Near PCCP

No geotechnical drilling is allowed within 10 feet of PCCP. Any other type of drilling (e.g., pile, foundation, drilled shaft) must be at least 20 feet from the pipe. Variance requests may be approved and shall be submitted to WSD with a mitigation plan and be approved prior to the start of work.

WSD Coordination and Inspections

WSD shall be notified prior to PCCP being exposed. While the PCCP is exposed, WSD will perform visual inspection and/or non-destructive test of the exposed pipe section when the pipe is first exposed and prior to backfill.

E. FIRE LINE SYSTEMS

A fire line is a private pipe system connected directly to the City water system. All maintenance of the private fire line is the responsibility of the property owner and begins at the control valve located within the public right-of-way or water easement. A fire line, by the nature of its function and use, is susceptible to backflow. Consequently, it is subject to the requirements for backflow prevention. Above ground installation of backflow prevention devices shall conform to the requirements as written in City Code, Chapter 37, Article XII.

A fire line shall be utilized for fire protection only and shall serve only a single property. Typically, a fire line is a connection for on-site private hydrants or an interior fire sprinkler system for a building. WSD's review and approval interest is limited only to that portion to be constructed in the ROW or water easement.

1. Acceptable Pipe Materials

All fire line installations shall conform to the applicable MAG Specifications and Details and the COP Supplements thereto. A fire line sized 4 inches or larger shall be constructed of DIP from the control valve at the water main to the property line, backflow prevention device or detector check valve.

2. Design Requirements

All fire line installations shall be approved and permitted collectively by the Fire Department, PDD and WSD. Fire lines shall conform to the City Fire Code and the following WSD requirements:

- a. The standard size for fire line connections shall be 4 inches or larger. Fire lines smaller than 4 inches will require a meter. The meter will be installed by the City with an approved application and will be locked in the open position. Meters on fire lines shall be sized to deliver the required fire flow. Refer to meter size table and riser fire flow requirements.
- b. Every fire line shall connect perpendicular to the public water main with a control valve. Fire lines cannot be installed at the end of a dead-end main.
- c. If the Fire Department determines that a fire pump system is needed requiring a redundant water source (i.e., two fire line connections), the water supply shall be provided from multiple water mains serving the same pressure zone. If two water mains are not available and the fire lines shall connect from a single source, WSD must review the proposed connections prior to PDD approval (I.F.C 2018, Code 914.3.1.2.).
- d. Backflow prevention devices are required per the City of Phoenix Adopted Plumbing Code and the City Code, Chapter 37, Article XII. The backflow preventer shall be installed on private property and outside of the right-of-way or outside of the public utility easement. For additional requirements on backflow prevention, refer to Chapter III.
- e. Properties may require a detector check assembly with a bypass meter assembly when one or more of the following conditions exists or may exist:
 - There are hose connections on the on-site water system other than hose cabinets or racks.
 - There are fire hydrants or yard hydrants on the on-site water system, which are not equipped with a locking device approved by WSD. The keys to such locks shall be delivered to the Fire Department.
 - The on-site water system includes outlets for future connections.
 - The on-site water system allows fire demand flow rates to occur without activating an alarm.
 - There will be an obvious means by which water from the on-site fire system might be used for purposes other than firefighting.
 - Minimum cover over the fire line shall be determined by the City of Phoenix adopted Plumbing Codes.

NOTE: *The design engineer shall check with PDD as to the need for a detector check device in these cases.*

- f. The public water system can fluctuate 20 psi higher or lower than the average system pressure. The fire line shall be designed to accommodate the increase or decrease of pressure fluctuations.

- g. When fire line connections are allowed to be made from an RCP or a CCP distribution main, those connections will be in accordance with the guidance document “Procedure for Water Tapping Services into Reinforced Concrete Pipe (RCP) or Concrete Cylinder Pipe (CCP)” in **Appendix E**.

F. IRRIGATION SYSTEMS

In accordance with Section 37-110 and 37-112 of the PCC, a Landscape Water Permit is required for irrigation of turf-related facilities. A turf-related facility is defined as a site that has 10 or more acres of turf or high-water-use landscaping. Schools, parks, cemeteries, and golf courses typically fall into this category.

A permit application must be obtained from WSD Water Resources - Water Conservation Office. WSD shall make the determination of when potable or non-potable water is acceptable for use per PCC and State requirements. The developer will need to enter into a contract for the sale and use of non-potable water before the service connection can be approved.

G. FIRE HYDRANT REQUIREMENTS

Public fire hydrants shall be located where they can be quickly found and easily used by fire engines arriving at an incident. Standardized location criteria is based on predictability, visibility, unobstructed accessibility, the type of development, Fire Department tactical needs, and the expected route fire engines will travel to the site.

Determining proper fire hydrant location requires the application of engineering judgment and common sense to the specific conditions found in each project. Minor variances in the locations or spacing of individual hydrants may be approved provided the functional intent of these design standards is achieved.

1. Location and Design Requirements

- a. Shall be installed in the public right-of-way or a dedicated water easement.
- b. Located on the right hand (passenger) side of streets, intersections, driveways, entrances to a development and fire lanes within 6 feet of the curb. This location matches the hose connections on fire pumpers and allows the hydrant to be connected in the quickest, most efficient manner.
- c. When designing a fire hydrant layout, the first hydrant is to be located at street intersections and at the main entrance into a subdivision, apartment complex or commercial development. Additional hydrants shall then be spaced approximately evenly between these points at a distance not to exceed the maximum spacing between hydrants as shown in **Table 21, Fire Hydrant Spacing**. Spacing is measured along the route of travel of a fire engine.
- d. Located not less than 1 foot and not more than 6 feet from the back of curb along streets in accordance with the COP Supplement Detail P-1362.
- e. Place hydrant within 10 feet at the end of a dead-end water main that is greater than 100 feet in length to facilitate flushing and maintenance of the water main. However, a fire hydrant and valve may be placed directly at the end of a dead end main only if the hydrant is public and it's apparent that the water main cannot be extended any further, for example in cul-de-sacs or at the end of a water pressure zone.
- f. No hydrant will be required on a cul-de-sac if all houses are within 350 feet of a hydrant and the dead-end water main is less than 100 feet. The water main shall end with a tapped cap and a corporation stop, with a valve box and lock as approved by WSD.
- g. Do not obscure or obstruct hydrants behind fences, gates, walls or landscaping.

2. Coverage Requirements

- a. Existing fire hydrants on major (arterial) streets, collector streets or any other streets not divided by raised median islands or light rail tracks can be included in the coverage analysis. If those street classes are divided by raised median islands or light rail tracks, then the existing hydrant can only be included in the coverage analysis if it is located on the same side as the new development.
- b. Existing fire hydrants determined to be on a transmission main are intended for air relief, dewatering, and maintenance purposes and can be scheduled out of service periodically. Therefore, these fire hydrants shall not be included in the total count to meet a developer's fire hydrant coverage requirement. The bonnets on these hydrants are painted black.
- c. Fire hydrants separated from a subdivision, building or other development by a continuous fence, wall or other obstruction cannot be counted as providing protection to that subdivision or development. For example, where a residential subdivision is separated from its perimeter street by a continuous fence, fire hydrants shall be installed along the perimeter street (City Code Section 37-33) and internally along the streets within the subdivision, with hydrant spacing measured along the route of travel of the fire engine, not over the fence.

3. Clearance Requirements

All fire hydrants shall maintain a 6-foot horizontal clearance from any utility and above ground structures. Refer to COP Supplement Detail P-1359 for Hydrant Guards.

4. Specification Requirements

All fire hydrants shall be dry barrel type conforming to MAG Specifications 610, 756, COP Supplement 756 and COP Supplement Details P-1359, P-1360, P-1361 and P-1362.

5. Maximum Fire Hydrant Spacing

Table 21, *Fire Hydrant Spacing*, shows the maximum spacing for fire hydrants. Spacing distance shall be measured along the centerline of the street or route, which the fire truck will most likely travel.

Fire hydrant spacing requirements apply to all new developments, including those that do not need to install new public water mains. New developments adjacent to existing water infrastructure shall install the necessary hydrants to meet the spacing requirements. Deviation on public fire hydrants spacing of distribution mains must be submitted as a technical appeal to the City's Fire Marshall for approval.

Table 21. Fire Hydrant Spacing.

Development Type	Maximum Spacing (feet)
Single Family Residential	500
Townhouses and Apartments	300
Commercial and Industrial (including Shopping Centers) ¹	300

¹ A fire hydrant is required within 400 feet of the most remote building corner or the most remote hazard on site, measured as the hose lays along designated fire lanes or other clear access routes (within 600 feet of the most remote corner of fire sprinkled buildings).

6. Fire Hydrant Relocations

In the design phase of projects, every attempt should be made to locate driveways outside of existing fire hydrant locations. In the event that a hydrant must be relocated, the relocation shall be in accordance with COP Supplement Detail P-1344, which requires the existing service line and valve be cut and removed from the existing water main and a new section of pipe installed with a flexible coupling. A new fire hydrant service line shall be installed perpendicular to the new hydrant location.

In circumstances where the relocation of the existing hydrant would be 5 feet or less in either side-to-side direction, WSD will allow a 90 degree bend to be placed on the existing hydrant service line and the hydrant to be relocated (not applicable for black top hydrants). Hydrant relocations with a 90 degree bend will only be allowed up to a maximum distance of 5 feet (not applicable for black top hydrants).

Exceptions:

Black-top fire hydrants installed on the City's water transmission mains are intended primarily for system flushing and air-release maintenance at designated locations. Any request to relocate a black-top fire hydrant connected to a transmission main must be submitted to the Water Services Division (WSD) for review and approval through the Technical Appeal process

7. Private Fire Hydrants

Private hydrants are those hydrants located on private property and/or connected to any water line not owned and maintained by WSD. Private fire hydrants shall have their bonnets painted reflective white to identify them as privately owned and maintained. The property owner is responsible for maintaining all private fire lines and private fire hydrants.

V. WASTEWATER COLLECTION SYSTEM

A. GENERAL REQUIREMENTS

NOTE: Any and all more stringent requirements by Federal, State, County or local codes or ordinances shall take precedence.

1. Arizona Aquifer Protection Permit Requirements

The design of sewage collection systems shall conform to the requirements of the Aquifer Protection Permit General Permit rules in the Arizona Administrative Code, Title 18, and Article 5-505. An application for *Approval to Construct* and/or *Notice of Intent to Discharge* shall be submitted in accordance with AAC R18-9-A301(B) and E301(C). An *Approval to Construct* and/or *Provisional Verification of General Permit Conformance* shall be issued prior to commencing construction. *Approval to Construct* and/or *Provisional Verification of General Permit Conformance* include, but are not limited to, the following requirements:

- Engineer's Design Report.
- Complete construction-ready design plans.
- Specifications (CIP projects).
- All other relevant information to verify that the facility conforms to the terms of the Type 4.01 General Permit.

The design report, plans, and specifications shall be signed and sealed by an Arizona Registered Professional Civil Engineer.

The sewage collection system shall not be placed in service until an Approval of Construction and/or Verification of General Permit Conformance has been issued. Approval of Construction and/or Verification of General Permit Conformance includes, but is not limited to, the following requirements:

- An Engineer's Certificate of Completion sealed and signed by an Arizona Registered Professional Civil Engineer, attesting that the sewers have been constructed to the requirements of AAC R18-9-A301.
- As-built drawings, with each changed sheet sealed and signed by an Arizona Registered Professional Civil Engineer, are submitted to the WSD. Satisfactory test results from deflection, leakage, and uniform slope testing are confirmed by the COP.
- All other relevant information to verify that the facility conforms to the terms of the Type 4.01 General Permit.

2. Sewer Main Extension

Sewage collection systems shall comply with the requirements of Chapter 28 of the PCC. The sewer main extension policy of the COP is contained in Article III of Chapter 28 of the PCC. Developers shall pay all costs for constructing all elements of the public wastewater system authorized by the City. Under certain circumstances as described in Section 28-23 of the PCC, repayment of the cost of "off-site" sewer mains may be available. For procedures related to sewer repayment, refer to WSD Policy P-77, which is available on WSD's website. For website link refer to **Appendix A**, page A-2.

For developments that are located outside the City of Phoenix limits and are seeking to connect to the City's sewer system, refer to WSD's Policy P-105. For website link refer to **Appendix A**, page A-2.

Sewer extensions shall be designed for projected flows even when the diameter of the receiving sewer is less than the diameter of the proposed extension at a manhole with special consideration of an appropriate flow channel to minimize turbulence when there is a change in sewer size. A relief sewer may be planned in the future. All new sewer mains shall be extended to the point of need.

Sewers shall be laid with straight alignments between manholes. Curvilinear sewers are not permitted. Sewer alignment shall not meander across the street centerline.

B. GRAVITY SANITARY SEWER MAINS

1. Acceptable Pipe Materials

Gravity sewer mains shall be vitrified clay pipe (VCP), RCP or DIP as indicated below. For pipes 15 inches and smaller, WSD requires VCP to be used unless DIP is necessary for extra protection per MAG Specification 610.5.5, MAG Detail 404, and A.A.C. R18-5-502(c). Other materials may be used as approved by WSD through the Technical Appeal process. The pipe shall conform to the applicable specifications as follows:

- a. **VCP and Fittings:** MAG Specifications and the COP Supplement Section 743. VCP may be used for sewer mains 8 through 42 inches in diameter.
- b. **RCP and fittings:** MAG Specifications and the COP Supplement Sections 735 and 741. RCP shall be Polyvinyl Chloride Pipe (PVC) lined. RCP may be used for sewer mains 30 inches in diameter and larger.
- c. **DIP and fittings:** Per MAG Specifications and the COP Supplement Section 750, DIP may be used for sewer mains 8 inches through 54 inches in diameter. When DIP is used, it shall have Cured-in-Place Pipe (CIPP) lining in accordance with the proposed COP Supplement Section 751 - Ductile Iron Sanitary Sewer Lines. A copy of the specification is included in **Appendix F**.

Acceptable pipe materials for sewer service connections are listed in Section D.1.C.

2. Pipe Sizing

Gravity sewer mains shall be sized to accommodate the peak design flow subject to the following limitations:

- a. The d/D ratio for gravity sewer pipes shall be no greater than 0.75 at the peak flow condition.
- b. Minimum pipe size shall be 8 inches.

3. Slope

Gravity sewers shall be designed and constructed to provide velocities of not less than the velocities shown in **Table 22, Design Slopes**, based on Manning's formula, flowing full, and using an "n" value of 0.013. The minimum slopes required to maintain the minimum velocity are shown the table.

Designers shall minimize grade changes to be uniform throughout the entire pipeline project as well as from manhole to manhole. WSD will not permit the use of larger pipe diameters than required to carry the peak flow to reduce the slope.

Table 22. Design Slopes.

Pipe Sizing (inches)	*Minimum Design Velocity (feet/second)	Minimum Design Slopes (%)	Maximum Design Slopes (%)
8	2.1	0.380	6.980
10	2.2	0.306	5.121
12	2.3	0.256	3.919
15	2.4	0.205	2.880
18	2.4	0.140	2.390
21	2.5	0.146	1.890
24	2.6	0.127	1.520
27	2.6	0.115	1.378
30	2.7	0.102	1.113
36	2.7	0.085	0.945
42	2.8	0.073	0.754
48	2.9	0.064	0.616
54	3.0	0.058	0.522
60	3.0	0.051	0.430
66	3.1	0.047	0.396
72	3.1	0.043	0.362
78	3.2	0.040	0.316
84	3.2	0.037	0.293
96	3.3	0.032	0.238
108	3.3	0.028	0.208
120	3.4	0.026	0.182

** The velocities are based on the minimum required design shear stress recommendations provided in the American Society of Civil Engineers Manual of Practice No. 69 (MOP 69). These velocities will provide the design shear stress required to transport fine sand and grit particles less than 0.2 mm in diameter.*

4. Cover

Generally, all sewer mains shall have a minimum 7 feet of cover or a sufficient depth to serve the ultimate drainage area to include serviceable areas outside of the development project.

Sewer gravity mains installed with less than 4 feet of cover or sewer force mains installed with less than 6 feet of cover require approval by WSD through the Technical Appeals process. Sewer mains constructed in washes and floodways shall have their crowns at least 2 feet below the 100-year storm scour depth and shall be constructed with DIP with CIPP lining. The DIP shall extend a minimum of 10 feet on each side of the 100-year storm scouring, which would be manhole to manhole.

5. Sewer Main Connections at Manholes

There shall be no more than four connections at a manhole or structure, including the outlet sewer. Requirements for new connections at manholes are shown in **Table 22**.

At manhole connections, the angle between the upstream pipe and the downstream pipe shall conform to the following guidelines:

- Sewer mains 15 inches and larger in diameter shall not change flow direction more than 45 degrees in one manhole. Two manholes shall be constructed to change flow direction more than 45 degrees and up to 90 degrees.
- Sewer mains smaller than 15 inches in diameter shall intersect with manholes, maintaining a minimum of 90 degrees to the downstream pipe.
- The upstream pipe shall be the same or smaller diameter than the downstream pipe. Inverts through manholes and junction boxes shall be designed to maintain the energy gradient across the structure. Manholes and junction boxes having sewer mains intersecting at 45 to 90 degrees shall have a minimum 0.10-foot drop across the structure.

Table 23. Connections to Existing Sewer System (applies to new connections only).

CONNECTIONS TO EXISTING SEWER SYSTEM			
Existing Pipe Diameter	Proposed Pipe Connection Size	CONNECTION REQUIREMENT	
		Connecting to END Manhole	Connecting to THROUGH Manhole
Less than 15-inches	Same	Crown to Crown	Invert to Springline ¹
	Smaller than the existing pipe	Crown to Crown	Invert to Springline ¹
15-inches and Larger	Same	Crown to Crown	Invert to Springline ¹
	Smaller than existing pipe and less than 15-inches	Invert to Crown	Invert to Crown
	Smaller than existing pipe and \geq 15-inches	Crown to Crown	Crown to Crown

¹ For new systems.
NOTE: END manhole is a manhole that there is no upstream pipe connected to the manhole.
 THROUGH manhole is a manhole that there is an upstream pipe connected to the manhole.

6. Buoyancy

Buoyancy of sewers shall be considered, and flotation of the pipe shall be prevented with appropriate construction where high groundwater conditions are anticipated and within the 100-year floodplain where trenches could become saturated due to flooding.

7. Depressed Sewers

Depressed sewers, inverted siphons or sag pipes are not permitted.

C. MANHOLES

All manhole construction shall conform to MAG Specifications and Details and the COP Supplements to the MAG Specifications and Details except as detailed below:

- a. Aluminum manhole frames and covers are not permitted.
- b. Steps are not permitted in manholes.
- c. A manhole shall not discharge flows in more than one downstream direction unless approved by WSD.

1. Manhole Locations

Manholes shall be installed at the following locations:

- a. Changes of grade or slope.
- b. Changes of pipe size.
- c. Changes of horizontal or vertical alignment.
- d. Changes in pipe material.
- e. Service connections 8 inches in diameter and larger.
- f. The end of each public sewer main.

2. Manhole Spacing

The maximum spacing for manholes on sewer mains are shown in **Table 24, Maximum Manhole Spacing**. Spacing greater than shown in the table may be approved by WSD through the Technical Appeal process.

Table 24. Maximum Manhole Spacing.

Pipe Size (inches)	Maximum Manhole Spacing (feet)
Less than 15	400
15 to 24	500
Greater than 24	600

3. Manhole Diameter

The minimum manhole diameters and standard frame and cover sizes for various pipe sizes are shown in **Table 25, Minimum Manhole Diameters**.

Table 25. Minimum Manhole Diameters.

Pipe Diameter (inches)	Manhole Depth (feet)	Minimum Manhole Diameter (inches)	Minimum Frame and Cover Diameter (inches)
12 and Less	12 and Less	48	24
12 and Less	Greater than 12	60	30
15 and Greater	Any	60	30

4. Metering Manholes

Sewer main extensions or sewer taps will not be allowed into a metered manhole. Furthermore, no service connections will be allowed into the sewer main 100 feet upstream and 25 feet downstream of the metering manhole.

5. Clean Outs

Clean outs are not permitted. If the property owner/developer chooses to connect to an existing clean out at the end of a sewer main, the clean out shall be removed and replaced with a manhole.

6. Manhole Stub Outs and Knock Outs

Manhole stub outs and knockouts are not allowed. However, knock outs shall be provided in manholes for future main extensions when requested by WSD.

7. Drop Sewer Connections

Drop sewer connections for public sewer mains into a manhole shall conform to MAG Standard Detail 426 with the invert connection in compliance with the City's Standard Detail S-512D. Sewer connections with 5-foot or more drops create increased structural and maintenance risks for the City. Therefore, any request to use a MAG Type B drop manhole must be submitted to the Water Services Division (WSD) for review and approval through the Technical Appeal process.

8. Water Tightness

Manhole lift holes and grade adjustment rings shall be sealed with non-shrinking mortar.

Watertight manhole covers are to be used wherever the manhole tops may be flooded by street runoff or high water. Locked manhole covers may be required in isolated easement locations or where vandalism may be a problem.

9. Corrosion Protection for Manholes

All manholes for sewers 15 inches in diameter and larger, shall be coated in conformance with COP Supplement Section 626. Any disturbance of existing coatings shall be repaired in accordance with the manufacturer's recommendations.

10. Junction Structures

Junction structures shall be required on all sewer mains 33 inches and larger unless otherwise approved by WSD through the Technical Appeal process.

D. SERVICE CONNECTIONS

Service connections to the City of Phoenix Wastewater system shall conform to Article IV of Chapter 28 of the PCC, MAG Specification 615, COP Supplement Section 615.7, COP Supplement Details P-1431 and P-1440, and WSD Standard Details S-511, S-512, and S-512D.

Service connections are privately owned and maintained unless it is a single-family residential lot within a public right-of-way. Refer to WSD's Policy P-51, Service Lateral Maintenance Policy. The policy can be found on WSD's website: refer to **Appendix A**, page A-2 for WSD's website link.

1. Service Connection Installation Requirements

- a. Service connections to the sewer main shall be watertight and not protrude into the sewer. Saddle type connections shall not be used. All materials used to make service connections shall be compatible with each other and with the pipe materials to be joined and shall be corrosion proof.
- b. The design engineer shall note that WSD's procedures do not permit a contractor to set a service saddle connection on an existing sewer main. The contractor shall not connect to a City public main.
- c. The portion of the sewer tap located within the ROW shall be designed in accordance with the slopes set forth in the City's currently adopted plumbing code (IPC/UPC). Only VCP or DIP service connections are allowed within the ROW.
- d. Service connections shall extend perpendicular to the main. The invert of the service connection shall be at or above the crown of the sewer main, but no more than 12 inches above.
- e. Service Connection goes up to the end of right-of-way and ends at property line. For commercial development, the pipe needs to be the same size of the service tap.
- f. Accessory Dwelling Unit (ADU) and Middle Housing Unit Sewer Tap:

ADU and Middle Housing units must discharge sewer into the City's wastewater collection system.

ADU and Middle Housing Unit shall share sewer services with the property lot. Shared sewer service tap from the existing single-family home and ADU/Middle Housing Unit is still considered as a single-family residential tap.

If not technically feasible, ADU and Middle Housing may be allowed to have separate sewer taps connecting to the City's wastewater system through technical appeal process. The separate sewer tap for ADU/Middle Housing Unit is considered as privately owned and shall be maintained by the property owner. The size of the separate sewer tap for ADU/Middle Housing Unit shall follow "Residential Lots" Development Type in the DSM.

Per City Code 28-25 & 28-26, on-site private sewer disposal system is not allowed. If the existing property has a functioning septic tank and the tank has capacity to receive additional flow from the ADU/Middle Housing Unit as determined by the Maricopa County, the City may allow the sewer from the ADU/Middle Housing Unit discharge into the existing on-site septic tank through technical appeal process. Waterless toilets, on-site waste incinerators, or other similar systems are not allowed for ADU/Middle Housing Unit.

Customers shall provide ADU/Middle Housing Unit related plans and submittals to PDD for site, civil, fire and building review and approval, as required by the City. The sizing of the sewer taps shall meet the minimum requirements of the City Code, building code and this design standard manual.

2. Type of Developments Allowed to Share a Sewer Service Connection

WSD allows sharing a sewer service connection for different type of uses after written approval from WSD through the Technical Appeal process. For residential developments, the service connection must be located within a common tract deeded to the HOA. A commercial development may require a Developer Maintenance Agreement and a Building Code Modification, as approved by PDD.

- a. Two or more buildings located on the same lot (e.g., multi-family, manufactured home communities, or similar projects covering one lot).
- b. Single family residential attached (hybrid type developments) that do not comply with the City's Private Accessway and/or right-of-way requirements.
- c. Mixed Use Developments (residential and commercial) have the option to share or separate the sewer service connection for each use.
- d. Auto Court Cluster Developments (Cluster).
- e. Any single subdivision or development that cannot be served through a gravity sewer system and requires a lift station with a capacity less than 1 million gallons per day (MGD). The entire sewer system upstream of the service connection at the public gravity sewer will remain privately owned and maintained. Private sewers within a subdivision will be subject to approval of the PDD's Subdivision Committee by means of a Technical Appeal. Any encroachment of the private system into public ROW will require a revocable permit as dictated by the Street Transportation Department.

3. Service Connection Sizes

Table 26, *Service Connection Sizes*, shows the requirements based upon the development type:

Table 26. Service Connection Sizes.

Development Type	Services Connection Size (inches)
Residential Lots	4 or 6
Commercial Lots	Minimum 6
Multiple Lots	Minimum 6

4. Service Connections in Manholes

Service connections shall connect to existing sewer mains or manholes. Service connections into an existing manhole require a plan submittal of an S-511, S-512 or S-512D detail. The details are available on WSD's website. For website link refer to **Appendix A**, page A-2. Service connections on new sewer mains or manholes can be shown on the construction drawings and do not need a separate detail, provided they contain all the required information.

- a. Service connections 4 to 6 inches in diameter do not require a manhole connection unless the main size is 15 to industrial d30 inches in diameter.
- b. Service connections 8 inches in diameter and larger connecting into 8-inch to 30-inch diameter mains shall be installed directly into an existing or new manhole.
- c. Service connections of any size shall not connect directly into sewer mains that are 33 inches and larger. Such connections shall require a minimum 8-inch public sewer main extension, which shall be constructed from the nearest existing downstream manhole to the point of service unless otherwise approved by WSD through the Technical Appeal process.

- d. Service connections may be installed at an angle less than 90 degrees to the main, providing the installation does not restrict flow.

E. WASTEWATER LIFT STATIONS AND FORCE MAINS

Wastewater pumping stations and force mains shall conform to the City of Phoenix Lift Station Design Guidance Manual. This manual is available on WSD's website. For website link refer to **Appendix A**, page A-1.

Force mains connecting to an existing sewer main, shall submit an S-511 Sewer Detail and follow the S-511 (Manhole - Pressure Tap) Checklist. For website link refer to **Appendix A**, page A-1.

F. INDUSTRIAL AND COMMERCIAL DISCHARGE PRETREATMENT REQUIREMENTS

1. Code Requirements

In accordance with City Code Chapter 28, Article II and VI and when required by the Director, commercial and industrial users of the Publicly Owned Treatment Works (POTW) shall be required to install pretreatment systems, devices, and facilities as may be necessary to comply with EPA, State, and City requirements to ensure that discharges to the POTW do not have pass-through, exceedances of the permitted discharges, and any other negative impacts to the POTW infrastructure, POTW personnel, or the discharges from the POTW.

City Code Chapter 28, Article II, identifies pollutants, substances or wastewater that are prohibited to be discharged into the POTW without prior implementation of pretreatment technologies and compliance with monitoring and sampling as authorized by the Director. The owner must submit detailed design drawings for pretreatment technologies and compliance points that must be approved by the Director before construction can proceed. Access to commercial or industrial discharge points connecting to the POTW, pretreatment technologies, monitoring and sampling compliance points must be maintained to allow a Department representative to verify compliance with the requirements outlined in City Code Chapter 28.

The owner is responsible for identifying the characteristics of their discharge and coordinating appropriate pretreatment technologies that treat the discharge to the permit requirements, as outlined in City Code Chapter 28.

City Code Chapter 28, Article VI, mandates that industrial users maintain a minimum of three years of monitoring and sampling compliance data. Industrial users are also required, at their own expense, to install, calibrate, and maintain convenient and adequate monitoring and sampling points as specified by the Director. All monitoring and sampling locations must be accessible and safely situated to allow access by a Department representative and must be constructed in accordance with plans approved by the Director. Failure to keep monitoring facilities in good working order does not justify a user's claim that monitoring or sampling results are not representative of their discharges. Wastewater sampling equipment must utilize a 24-hour flow-proportional composite sampling technique unless an alternative method is approved by the Director. Wastewater flow monitoring equipment must continuously record average daily flow and maximum daily flow values, in gallons, unless otherwise approved by the Director.

2. Industrial Facilities

A Preliminary Survey (<https://www.phoenix.gov/waterservicessite/Documents/Industrial%20WW%20Survey.pdf>) is required to be submitted to IPP.PlanReview@phoenix.gov. All industrial facilities are required to submit a Preliminary Survey. Facilities that are determined to have processes listed in the *United States Code of Federal Regulations* Title 40 (40 CFR Part 400 through 40 CFR Part 471) will be required to apply for an Industrial Wastewater Discharge Permit, including Prohibited Discharge processes. All other facilities that are determined by the City as a Significant Industrial User or Industrial User of Concern will be required to apply for an Industrial Wastewater Discharge Permit. A full Industrial Wastewater Permit Application will

be required to be completed and submitted for review at this time. Additionally, any user of any property served by the City of Phoenix POTW carrying potentially harmful or industrial wastes with the intent to discharge to the POTW must install an approved compliance sampling point along with required infrastructure and monitoring equipment to facilitate observation, measurement, and sampling of the wastes to ensure discharged wastewater is within maximum permit limits.

Industries requiring compliance sampling and monitoring locations include, but are not limited to, the industries listed in **Table 27**. Additional, industry specific information can be found in the U.S. Environmental Protection Agency, Introduction to the National Pretreatment Program, Chapter 3.

Table 27. Industries Requiring Compliance Sampling and Monitoring Locations.

Adhesives Manufacturing	Food Processing	Paint Formulating
Aluminum Forming	Foundries (Metal and Molding Casting)	Pesticide Chemical Manufacturing
Any Industry Requiring Pretreatment	Glass Manufacturing	Petroleum Refining
Asbestos Manufacturing	Grain Mills	Pharmaceutical Manufacturing
Battery Manufacturing	Hospital	Porcelain Enameling
Carbon Black Manufacturing	Ink Formulation	Printing and Publishing
Coil Coating	Inorganic Chemical Manufacturing	Pulp, Paper, and Paperboard Manufacturing
Copper Forming	Iron and Steel Manufacturing	Rubber Manufacturing
Dye Manufacturing or Processing	Laboratories	Soap and Detergent Manufacturing
Electrical and Electronic Components Manufacturing	Laundries	Steam Electric Power Generation
Electroplating	Leather Tanning and Finishing	Sugar Processing
Feedlots	Mechanical Product Manufacturing	Semiconductor Wafer Manufacturing Facility
Ferroalloy Manufacturing	Metal Finishing	Tars and Asphalt Paving and Roof Material Manufacturing
Fertilizer Manufacturing	Nonferrous Metal Manufacturing	Textile Mills

See City Code Chapter 28, Article VI, for more information on these requirements.

Note: An Industrial Wastewater (IW) Permit Application is required to be submitted prior to or concurrently with the normal construction plan review and construction permit application process via the Planning and Development Department. Additionally, IIW Permit Application approval from the Environmental & Safety Division of the Water Services Department is required for pretreatment facilities and may be required for other facilities prior to issuance of building permits and before construction of those facilities can occur. Approval and issuance of the Industrial Wastewater Discharge Permit cannot be construed as a waiver of the City's right to enforce federal, state and the City's law and regulations in the field. Wastewater flow into the City's public sewer may not commence until all required wastewater treatment and compliance equipment has been installed and approved by the City.

For more information, go to: <https://www.phoenix.gov/waterservices/envservices/indpretreatmentprog>.

3. Sampling Facility Requirements

All compliance sampling point installations shall be in accordance with City Code Chapter 28, Article VI, Sec 28-44.2. The compliance sampling point shall be located as close as practicable to the property line between the public right of way and the discharger's property, downstream of any pretreatment

technologies. The location shall be accessible to City staff for inspections and collecting compliance samples.

The primary compliance sampling point shall be operated and maintained by the discharger and the sampling location shall be designed to facilitate City staff temporarily installing and operating equipment for the purposes of collecting independent verification samples. Detail 1 presents a typical detail outlining the minimum requirements for the sampling facility. The discharger shall prepare a site-specific detail for the compliance sampling point showing actual sewer invert and ground elevation data and location for City staff access and parking.

4. Flow Monitoring Facility Requirements

All compliance flow monitoring facility installations shall be in accordance with City Code Chapter 28, Article VI, Sec 28-44.2. Drawings and specifications detailing sampling and monitoring locations and devices must be submitted and approved by the Director. The location shall be accessible to City staff for inspections and downloading historical flow metering data from the compliance flow meter.

The flow measurement system may be an open-channel pipe design with an ISCO Laser (or comparable manufacturer) Flowmeter installed per Detail 1, or if the installation of a laser is not practical, an appropriately selected open channel flow device (i.e., flume or weir) can be constructed, per Detail 2, to monitor discharges. Closed-pipe flow measurement systems will only be accepted if an open-channel flow measurement system is physically impractical to install, with approval from the Director. The compliance flow meter shall be operated and maintained by the discharger, and the flow metering installation shall be designed in accordance with the flow meter manufacturer's requirements to facilitate optimum accuracy for the recorded flow measurement. The discharger shall prepare a site-specific detail for the compliance flow metering facility showing actual sewer invert and ground elevation data and location for City staff access and parking.

5. Pretreatment By-pass Requests

All pre-treatment by-pass requests under Section 28-11.1.(d) must be submitted to the City through WSD technical appeal process for review and approval.

6. Commercial Facilities

Food Service Establishments (including commissaries), Automotive Repair, Carwashes, Dental, Hospitals, Laundromats, People and Pet Grooming Facilities, Bakeries, Butcher Shops, Breweries, Coffee Houses, RV and all other sediment/solids, fats, oils, or grease producing operations will be required to install a COP approved pretreatment interceptor device for the proper handling of liquid wastes containing grease, oil, any flammable wastes, sand, or other harmful ingredients in excessive amounts. Hair traps are required for grooming facilities. Dump Stations will require signage prohibiting dumping of harmful pollutants - only domestic RV wastes are allowed. The plumbing drawings shall include the location of all exterior pretreatment devices and the engineering calculations for size determination. Additionally, reference to the location of pretreatment devices and dump stations is required on the site plan.

Interceptors are required, but not necessarily limited to, the following commercial facilities listed in **Table 28**. Interceptor sizing and capacity shall be per calculations by an Engineer registered in the State of Arizona and approved by the Director. Interceptors shall be 24-hour accessible for cleaning and inspection. Grease and oil interceptors shall be constructed of impervious materials capable of withstanding abrupt and extreme changes in temperature. Maintenance shall be performed at a minimum of every 90 days or as determined by the Director. All photo processing facilities, dental offices, and x-ray processing facilities shall be equipped with a metals recovery unit, as approved by the Director.

Table 28. Commercial Facilities Requiring Interceptors.

Restaurants	All Types, Fast Food Chains, Pizza Delivery, Sandwich Shops, Bakeries
Service Stations	Auto Repair, Car Washes, Fuel Stations
Hair Trap Required Business	Pet Grooming, Salons, Laundry Facilities
Other	Any Other Facility Deemed Necessary For Potential Discharge by the City of Phoenix.

For more information, go to:

<https://www.phoenix.gov/waterservices/envservices/comminsp>

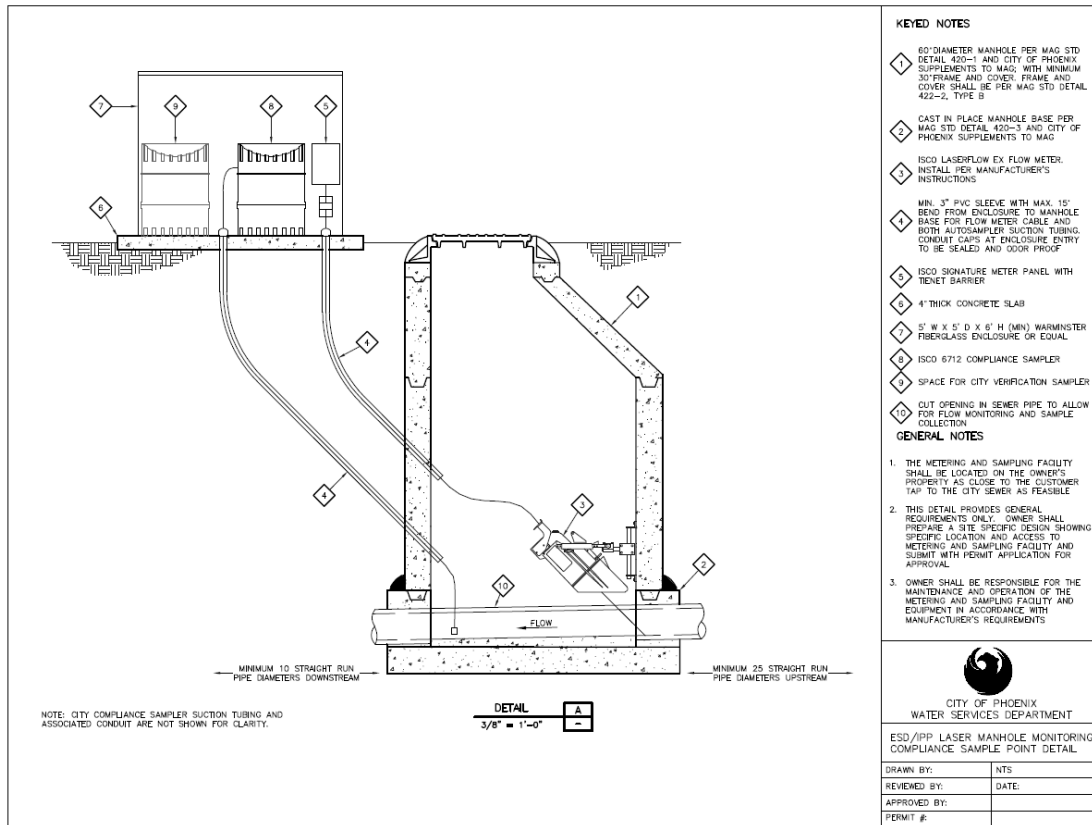

Figure 10. Detail for ESD/IPP Laser Manhole Monitoring Compliance Sample Point Detail

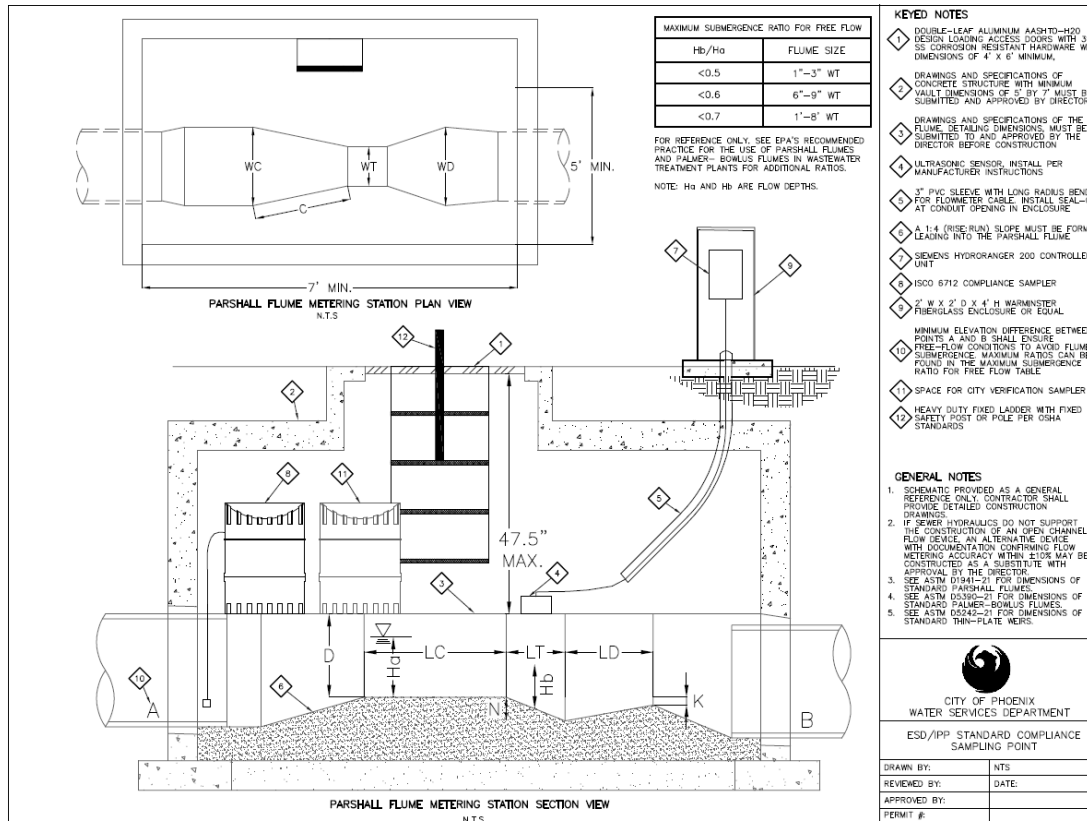

Figure 11. Detail for ESD/IPP Standard Compliance Sampling Point

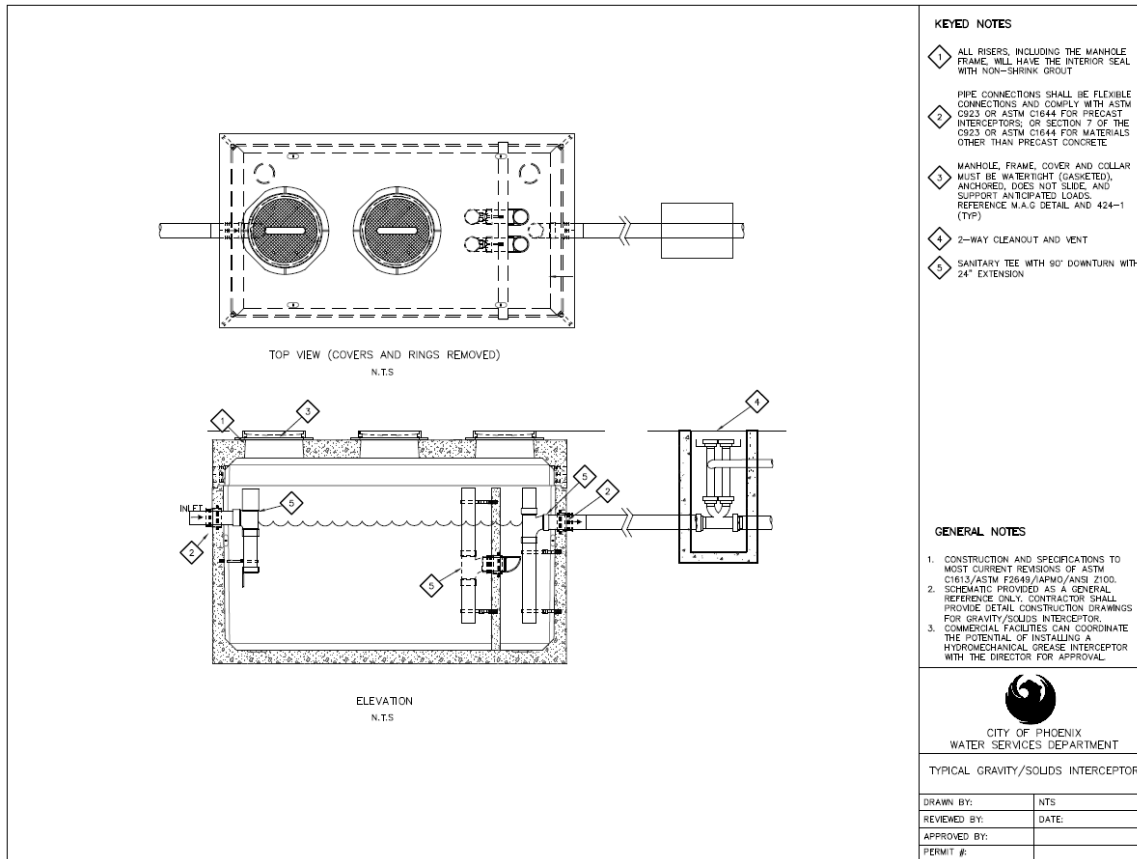

Figure 12. Typical Gravity/Solids Interceptor

G. SEPTIC SYSTEMS WITHIN THE CITY OF PHOENIX

1. City Ordinances Which Apply to Septic Systems

City Code 28-25, Private Sewage Systems - Construction and maintenance within the City prohibited generally, states the following: *“Except as expressly provided in this chapter, it is unlawful to construct or maintain within the City or an area of the City jurisdiction a private sewer system, including any privy, privy vault, septic tank, cesspool, onsite wastewater treatment system, or other facility intended or used for the disposal of sewage..”*

City Code 28-26, Private Sewage Systems - Limited instances permitted; to be constructed and maintained in sanitary manner, states the following: *“Only in those limited instances in which there is no public sewer available to connect to may a home or building located within the City or an area of the City’s jurisdiction connect to a private sewer system. The private sewer system must be designed, installed, maintained, and operated or used at all times in strict conformance with State and County private sewer system requirements. When a public sewer becomes available for connection, the home or building must discontinue its use of the private sewer disposal system and connect to the public sewer.”*

2. When NEW Septic Systems May Be Allowed

COP does not allow private sewer systems. Therefore, COP will require that all properties within the service area connect to the public sewage system. However, if a property falls into one of the following exceptions, the sewer main extension will not be required:

- a. A new single residence on a single lot whose closest lot line is more than 250 feet from an existing public sanitary sewer main.

- b. A new commercial or residential development that is provided COP water but is outside COP limits. Septic requirements for properties outside of COP limits are ultimately determined by the property's jurisdiction (i.e., County, Town of Cave Creek, or Paradise Valley).

If one of these exceptions is met, the property owner may then contact the MCDES for approval of an on-site private sewage treatment system.

3. When Existing Septic Systems May Remain In Use

Existing residential or commercial septic systems that are properly permitted, operational, and have been deemed adequate by the County to continue serving the site, are allowed to remain. In addition, if a single residence or commercial development increases the calculated sewer flows to the system (per approved plumbing code), and the existing septic system has capacity to accept the increase in flows, the developments may remain on the existing septic system.

Any development on an existing septic system shall be required to connect to COP's public sewer system if one of the following occurs:

- a. The existing septic system needs major repairs.
- b. The existing septic system needs to be upgraded/increased in size in order to accept an increase in calculated sewer flows (per approved plumbing code).
- c. The existing septic system needs to be relocated on the property.

VI. APPEAL PROCESS FOR WATER/SEWER REQUIREMENTS

A. PURPOSE OF TECHNICAL APPEALS

The purpose of this section is to provide customers with a description of the COP's WSD and PDD appeal processes relating to all water and wastewater requirements.

WSD, in coordination with PDD, both stipulate water and wastewater infrastructure requirements for all developments within the City of Phoenix.

- If the customer does not agree or cannot meet the water/sewer stipulations or the requirements of this design standards manual or Phoenix City Code, they may file a Technical Appeal (Appeal) to the Water and Sewer Technical Appeal Review Committee (Committee) through WSD.Appeals@phoenix.gov (see below for the process).
- Appeal packages must provide a written narrative, exhibit, and any other materials related to the appeal. All Appeals must include a technical basis for the deviation request. Cost and convenience are not considered technical basis. Examples of acceptable technical basis include:
 - A code section that is being misinterpreted or incorrectly applied to the project.
 - Engineering analysis demonstrates that existing site constraints (such as topography, existing utilities, structural limitations, or safety risks) cannot be reasonably modified, making strict compliance infeasible.
 - An alternative design approach that provides equal or greater safety, performance, or capacity compared to the code requirement.
 - Field verified physical site conditions that make the standard installation or configuration infeasible to implement.

- Situations where compliance would negatively impact the performance of the City's water or wastewater system.
- In any appeal where the Applicant believes that a "takings" has occurred, the Applicant has the option to pursue the City's Proportionality Appeal Process. This type of appeal is submitted through PDD.
- For appeal fees, refer to PDD's current fee schedule or page two of the Appeal application.

NOTE: The approval for a technical appeal is valid for 5 years starting from the issued date of approval. Technical appeals that are five years or older are considered invalid and null. In addition, for technical appeals that are still valid, if the appealing section gets updated or changed during this 5-yr period, a re-submittal of the technical appeal may be required, as determined by the WSD.

B. DEVELOPER AND HOMEOWNER APPEALS

Developer and Homeowner Technical Appeals to the Water and Sewer Technical Appeal Review Committee (Committee): A Technical Appeal application is submitted to WSD, through WSD.Appeals@phoenix.gov for prescreening and approval sign off, where an appeal fee is charged per appealable item. A reduced appeal fee is applied to the Homeowner appeals. The signed appeal application will need to be submitted through ProjectDox.

The appeal is reviewed by the Committee, which is comprised of a minimum of two (2) WSD professional engineers and two (2) PDD professional engineers. The Committee reviews the appeal to determine the type of appeal.

- If the applicant is appealing WSD design standards:
 - The appeal will be either approved as is; approved with stipulations or changes; or denied.
 - For these types of appeals denied by the Committee, the applicant may submit a subsequent appeal package with the WSD Director's Representative. Refer to Subsequent Technical Appeal Process section.
- If the applicant is appealing City Code chapters 28 or 37 (water and sewer):
 - The WSD Director's Representative has delegated authority to the Committee to render decisions on appeals where the requirements are established in both DSM and City Code.
 - For appeals involving requirements found exclusively in City Code, the WSD Director's Representative will evaluate the complete appeal package and issue their determination.

The Committee will typically hear cases within ten business days after a complete application is received, and fees are paid. A response letter will be provided typically within ten business days after a final decision is made.

D. SUBSEQUENT TECHNICAL APPEAL PROCESS

If an appeal was denied at the committee level and the applicant wants to appeal to WSD Director's Representative level, a subsequent appeal application must be submitted to WSD, through WSD.Appeals@phoenix.gov for prescreening and approval sign off, where an appeal fee is charged per appealable item. The subsequent and signed appeal application will need to be submitted through ProjectDox. The WSD's Representative will then evaluate the complete appeal package and issue their determination, with or without a formal hearing. A response letter will be provided typically within ten working days after a decision is made.

E. WSD DIRECTOR'S REPRESENTATIVE INTERPRETATION OF CITY CODE PROCESS

As stated above, City Code chapters 28 and 37 (water and sewer) cannot be waived and only WSD Director's Representative has the authority to interpret the Code. It is the responsibility of the applicant to propose to the representative what can be done differently to still meet the intent of the Code. If the appeal is denied, the applicant may pursue further appeal to DAB or legal recourse with the Maricopa County Superior Court.

F. UTILITIES CROSSING PROPERTY LINES APPEALS

City Code 37-48 and 28-29 does not allow water, fire and sewer services connections crossing property lines. All such appeals may be reviewed and approved/denied at the Committee level, and shall follow the following procedure:

a. Fire Service Connections Crossing Property Lines:

For fire service line crossing property line appeals, applicants must first file a technical appeal to the City's Fire Marshall. If the appeal is approved by the Fire Marshall, applicants may then file a technical appeal to WSD with the approved fire appeal attached in the submittal.

b. Water and Sewer Service Connections Crossing Property Lines:

For water and sewer service lines crossing property line appeals, applicants must first file a technical appeal with WSD.

G. OTHER APPEALS

City Code 13.12.320, 28-1 and 28-8 requires separation of storm water collection system and the City's sanitary sewer collection system. No development shall discharge storm water into the City's sanitary sewer system, unless approved by the City's Water Services Department through a water/sewer technical appeal process.

APPENDIX A - Website Links

WEBSITE LINKS

The following is a list of useful website links that are references in the design manual and other related items to water and sewer.

WATER SERVICES DEPARTMENT'S MAIN WEBSITE

<https://www.phoenix.gov/waterservices>

WATER SERVICES DEPARTMENT'S WATER AND WASTEWATER DEVELOPMENT INFORMATION

<https://www.phoenix.gov/waterservices/devinfo>

WATER SERVICES DEPARTMENT'S DESIGN MANUALS, CHECKLISTS, ENGINEERING DETAILS, POLICIES AND PROCEDURES

Design Manuals

- Design Standards Manual for Water and Wastewater Systems
- Addendum for Water and Sewer in Light Rail Corridors
- Wastewater Lift Station Design Manual
- Water Remote Facilities Design Guidance Manual
- Wastewater Lift Station Design Manual

Requirements for Corrosion Protection Design Standards

Checklist Requirements for Water and Sewer Plans

Water and Wastewater Engineering Details

Water and Wastewater Engineering Polices

<https://www.phoenix.gov/waterservices/publications>

SPECIFICATIONS AND DETAILS

Maricopa Association of Governments (**MAG**) Specifications and Details

<https://www.azmag.gov/Newsroom/Publications>

City of Phoenix Supplement Standards, Specifications

<https://www.phoenix.gov/streets/reference-material/autocad>

Maricopa County Environmental Services Department (**MCESD**) – Environmental Forms

<http://www.maricopa.gov/ENVSVC/>

Salt River Project – Water Construction and Engineering Standards

<https://www.srpnet.com/water/services/WE/default.aspx>

ARIZONA DEPARTMENT OF ENVIRONMENTAL QUALITY (ADEQ)

Arizona Administrative Code Title 18, Water Pollution Control

<http://www.azsos.gov/rules/arizona-administrative-code>

Arizona Pollutant Discharge Elimination System (**AzPDES**) Permit

<https://azdeq.gov/Permits/Listing>

CITY OF PHOENIX WATER AND SEWER CHAPTER CODES

Chapter 19A: Residential Development Occupational Fee – Sewer
Chapter 19B: Commercial and Industrial Development Occupational Fee – Sewer
Chapter 19C: Residential Development Occupational Fee – Water
Chapter 19D: Commercial and Industrial Development Occupational Fee – Water
Chapter 28: Sewer
Chapter 30: Water Resources Acquisition Fee
Chapter 37: Water

<http://www.codepublishing.com/az/phoenix/>

PLANNING AND DEVELOPMENT DEPARTMENT WEBSITE

A to Z Topics – All topics relating to development

<https://www.phoenix.gov/pdd/topics-a-to-z>

Civil Topics – Applications, checklists, forms, etc.

<https://www.phoenix.gov/pddsite/Pages/civilindex.aspx>

Fee Schedule

https://www.phoenix.gov/pddsite/Documents/TRT/dsd_trt_pdf_00042.pdf

Boundary Map for City's Infill Development District

https://www.phoenix.gov/pddsite/Documents/infill_gpa_map_r-21189.pdf

STREET TRANSPORTATION DEPARTMENT WEBSITE

City of Phoenix Standard Utility Locations Manual

<https://www.phoenix.gov/streets/utility-coordination>

APPENDIX B - Definitions and Terms

DEFINITIONS and TERMS

Whenever in this manual the following terms are used, the intent and meaning shall be interpreted as follows:

ADEQ: The Arizona Department of Environmental Quality.

Auto Court Cluster (Cluster): A single-family detached development with lots having a shared or common access drive between single-family detached lots. The lotting configuration for Clusters development shall not exceed six (6) lots with only one point of access unless approved by the PDD. Where detached single-family lots exceed 6 lots or single-family lots are not detached, the development does not fall into this category.

AzPDES Permit: An Arizona Pollutant Discharge Elimination System permit, issued to the City or other operating entity by the ADEQ, which imposes federal standards governing the quality of the treated effluent discharged from the Publicly Owned Treatment Works (POTW).

Backfill: Material placed in an excavated space to fill such space. For trenches, this space will be the area from one (1) foot above the top of the pipe or conduit to the existing or proposed finished grade of pavement.

Backflow: The flow of water or other liquids, mixtures, gases, or other substances into the distributing pipes of a potable supply of water, from any source or sources other than the City potable water system.

Backflow Prevention Device - Approved: An air gap, double check valve assembly, reduced pressure principle backflow prevention device or other backflow prevention device or method approved by the Building Official of the City of Phoenix.

Bedding: The material placed in the area from the bottom of the trench to one (1) foot above the top of the pipe or conduit.

Building: Any structure built for the support, shelter or enclosure of persons, animals or movable property.

Building Code: A regulation adopted by the Phoenix City Council establishing minimum standards of construction for the protection of the public health, safety, and welfare in terms of measured performance rather than in terms of rigid specification of materials and methods.

Building Official: The Assistant Director of the Planning & Development Services Department in charge of the Building Service Branch, or their authorized representative.

Building Sewer: The extension from the building drain to the building connection or other place of disposal.

City: The City of Phoenix.

Council: The City of Phoenix City Council.

County: Maricopa County.

Cross Connection: Any physical connection or arrangement between two otherwise separate piping systems, one of which contains potable water and the other water of unknown or questionable safety or steam, gas or chemical whereby it is possible there may be a flow from one system to the other, the direction of flow depending on the pressure differential between the two systems.

De Minimis General Permit: (DGMP): A general permit issued by ADEQ designed to cover discharges from potable or reclaimed water systems, subterranean dewatering, well development, aquifer testing, hydrostatic testing of pipelines and tanks, residential cooling water, charitable car washes, building and street washing, and dechlorinated freshwater swimming pool drainage.

Developer: Any person engaged in the organizing and financing of an improvement or addition to a water, reclaimed water or wastewater system forming a part of the City of Phoenix systems. A Developer may be a landowner, subdivider or legally constituted improvement district.

Director: The Director of the Water Services Department or their authorized deputy, agent or representative.

Discharge: The disposal of sewage, water or any other liquid or liquid/solids mixture by any sewer user into the sanitary sewer system.

Distribution Mains: Water mains 16 inches and smaller in diameter.

Distribution System: Water mains under 16 inches in diameter together with all appurtenant and necessary valves, fire hydrants, taps, meters, service pipes, and associated materials, property, and equipment receiving potable water from transmission mains and distributing it to individual consumers.

Engineer: The person appointed as City or County Engineer by the Council or the Board of Supervisors, acting directly or through their duly authorized representative. Also, the design engineer of the improvements, whether or not this person is the City or County Engineer.

Fire Line: A fire line is a private pipe system connected directly to the City water system. A fire line shall be utilized for fire protection only and shall serve only a single property.

Force Main: Wastewater main operating under pressure induced by mechanical pumping.

Irrigation System: An irrigation system is a private pipe system connected directly to the Phoenix water system through a metered service connection. An irrigation line is utilized for irrigation only.

Interceptor Sewer: Sanitary sewers 15 inches and larger usually at the lowest elevations in the wastewater system into which tributary sewers discharge. Interceptors usually transport the wastewater to the treatment facilities.

Maintenance: Keeping the water and wastewater works in a state of repair, including expenditures necessary to maintain the capacity and capability for which said works were designed and constructed.

MAG: The Maricopa Association of Governments.

Manhole: A means of access to utilities such as sewer mains for the main purpose of inspection and cleaning.

Permit: The license to do construction in public rights-of-way and/or easements issued by an Agency to a Contractor working for another party.

Person: Any individual, partnership, firm, company, corporation, association, joint stock company, trust, state, municipality, Indian tribe, political subdivision of the state or federal governmental agency or any other legal entity, including their legal representatives, agents or assigns.

Plans: All approved drawings or reproductions thereof pertaining to the work and details therefore.

Private Accessway: A private street within a development built to City standards with a homeowner's association established for maintenance primarily for single family residential use.

Private Sewer and Lift Station: A privately owned piping system designed expressly for the purpose of collecting wastewater generated within a private development site and transporting it to the public sanitary sewer system.

Project: A specific coordinated construction or similar undertaking identified by a single project number and bid and awarded as one contract. On occasion, two or more projects may be bid and awarded as a single contract.

Public Sewer: A sanitary sewer controlled and maintained by the City of Phoenix.

Reclaimed Water: Water that has been treated or processed by a wastewater treatment plant or an on-site wastewater treatment facility (A.R.S. 49-201). Reclaimed water is further defined in ADEQ Regulation R18-11 by Classes based upon the degree of treatment.

Relief Sewer: A sewer built to carry the excess flows of an existing sewer with inadequate capacity.

Right-of-way: A general term denoting land, property or interest therein, usually in a strip, acquired for or devoted to a street, highway or other public improvement.

Roadway: The portion of the right-of-way intended primarily for vehicular traffic and including all appurtenant structures and other features necessary for proper drainage and protection. Where curbs exist, it is that portion of roadway between the faces of the curbs.

Service Connection: A private connection to the public water or sewer system. For domestic/landscape water, the meter is the point of connection. For a fire line, the point of connection is the fire line valve nearest to the public water main. For sewer, the point of connection is at the public sewer main/manhole. A meter water service connection goes up to the end of right-of-way and ends at the meter. The pipe needs to be the same size of the tap in the right of way; and meet the applicable code.

Sewage: Any liquid or water carried pollutant or waste including industrial discharge, which is introduced into the POTW from any dwelling, commercial building, industrial facility, or institution together with such inflow as, may be present. Also known as sanitary sewage.

Sewer: A pipe or other conduit, that carries wastewater (sewage). Sewers are classified by function rather than size.

Sewer Tap: The wye, saddle or other device placed on a public sewer to receive a building connection.

Shop Drawings: Drawings or reproductions depicting detailing, fabrication and erection of structural elements, false work and forming for structures, fabrication of reinforcing steel, equipment and installation of such equipment or other supplementary plans or similar data for specified construction that the Contractor is required to submit for approval prior to fabrication, installation or construction.

Sidewalk: That portion of the roadway primarily constructed for the use of pedestrians.

Specifications: The descriptions, directions, provisions, and requirements for performing the work as contained in the Contract Documents.

Standard Details: Uniform detail drawings of structures or devices adopted as Standard Details by the Department.

Standard Specifications: Uniform general specifications adopted as Standard Specifications by the Department.

Storm Sewer: A sewer that carries storm runoff, other surface water, street wash, other wash waters or drainage, but excludes domestic wastewater and industrial wastes. Also called storm drain.

Street: Streets, avenues, alleys, highways, crossings, lanes, intersections, courts, places, and grounds now open or dedicated or hereafter opened or dedicated to public use and public ways.

Structures: Bridges, culverts, catch basins, drop inlets, retaining walls, cribbing, manholes, end walls, sewers, service pipes, under drains, foundation drains, fences, swimming pools, and other features, which may be encountered in the work and not otherwise classed.

Substandard Main: An existing main determined to be unsuitable for use based on its size

System Design Capacity: The system capacity for normal operation as established by accepted engineering standards.

Transmission Main: A water main 16-inches and larger in diameter.

Transmission System: The system of water mains generally larger than 16 inches in diameter together with all necessary valves and other equipment required for delivering potable water to the Distribution System.

Utility: Pipe lines, conduits, ducts, transmission mains, overhead or underground wires, railroads, storm drains, sanitary sewers, irrigation facilities, street lighting, traffic signals, and fire alarm systems, and appurtenances of public utilities and those of private industry, businesses or individuals solely for their own use or use of their customers which are operated or maintained in, on, under, over or across public right-of-way or public or private easement.

Water System: Consumer's Potable: That portion of the privately owned potable water system lying between the service connection to the public potable water system and the point of use. This system includes all pipes, conduits, tanks, receptacles, fixtures, equipment and appurtenances used to produce, convey, store or use potable water.

Wastewater (Sewage): The combination of the liquid and water-carried wastes from residences, commercial buildings, industrial plants and institutions together with any inflow that may be present.

Waterworks System (Water Supply System): The reservoirs, pipelines, wells, pumping equipment, purification works, mains, service pipes, and all related appliances and appurtenances utilized in the procurement, transportation and delivery of an adequate, safe, and palatable water supply for the City.

Wastewater System: The pipelines, manholes, junction structures, lift stations, force mains, and appurtenances utilized in the collection, transport, and delivery of wastewater (sewage) to wastewater treatment facilities.

APPENDIX C - Acronyms

ACRONYMS

The following is a listing of primary acronyms used in this manual. All references to documents, manuals, standards or specifications of other agencies or organizations (i.e., AWWA C400) refer to the latest edition or revision thereof unless specifically annotated to the contrary.

AAC	Arizona Administrative Code
ABC	Aggregate Base Course
ADEQ	Arizona Department of Environmental Quality
ADP	Asset and Development Planning
APP	Aquifer Protection Permit
ARS	Arizona Revised Statutes
AWWA	American Water Works Association
AzPDES	Arizona Pollutant Discharge Elimination System
CCP	Concrete Cylinder Pipe
CC&Rs	Conditions, Covenants, and Restrictions
CIP	Cast Iron Pipe or Capital Improvement Project or Program
COP	City of Phoenix
DOF	Development Occupation Fees
DIP	Ductile Iron Pipe
FPS	Feet per Second
FT	Foot or Feet
GIS	Geographical Information System
GPM	Gallons per Minute
GPD	Gallons per Day
IPC	International Plumbing Code
MAG	Maricopa Association of Governments
MCESD	Maricopa County Environmental Services Department
OD	Outside Diameter
PC	Point of Curvature
PCC	Phoenix City Code
PCCP	Pre-stressed Concrete Cylinder (Steel) Pipe
PDD	Planning and Development Department
PRV	Pressure Regulating or Reducing Valve
PSI	Pounds per Square Inch
PT	Point of Tangency
PVC	Polyvinyl Chloride Pipe
Q	Rate of Flow
RCP	Reinforced Concrete Pipe
ROW	Right-of-Way
STR	Street Transportation Department
SFA	Single-Family Attached (Dwelling)
UPC	Uniform Plumbing Code
VCP	Vitrified Clay Pipe
WRA	Water Resource Acquisition Fee
WSD	Water Services Department

APPENDIX D - Requirements for Corrosion Protection Design Standards Development Report for Large Diameter Ductile Iron, Steel, CCP, and RCP Water Transmission Pipelines

**PROPOSED REQUIREMENTS
FOR
CORROSION PROTECTION
DESIGN STANDARDS DEVELOPMENT REPORT
FOR
LARGE DIAMETER DUCTILE IRON, STEEL, CCP
AND RCP WATER TRANSMISSION PIPELINES**

Prepared For:

**THE CITY OF PHOENIX
Water Services Department**

Prepared by:

**BROWN AND CALDWELL
and
CORROSION PROBE, INC.**

Revision 2: 12 September 2012

BROWN AND CALDWELL, INC.
201 EAST WASHINGTON STREET • SUITE 500 • PHOENIX, AZ 85004
PHONE: (602) 567-4000 • FAX: (602) 567-4001 www.browncaldwell.com

CORROSION PROBE, INC.
Corporate Headquarters:
12 INDUSTRIAL PARK ROAD • P.O. BOX 178 • CENTERBROOK, CT 06409-0178
PHONE: (860) 767-4402 • FAX: (860) 767-4407 www.cpiengineering.com



*The Complete Engineering Approach —
From Detection to Correction.*

TABLE OF CONTENTS

SECTION	PAGE NO.
1.0 Introduction	1
2.0 Corrosivity Assessment Grading For Selecting Corrosion Protection Methods	3
3.0 Corrosion Protection Methods Matrices	7
4.0 Major Corrosion Protection Options By Large Diameter Pipe Material Of Construction – Background Information	10
5.0 Recommendations For Corrosion Protection Methods For Large Diameter Pipe By Materials of Construction	17
Appendices A and B	27

1.0 INTRODUCTION

This report documents the completion of Task 4 of the Large Diameter Metallic Pipe Corrosion Protection Design Standards Development. The City's relevant existing drawings and specifications have been carefully reviewed and supplemented for corrosion control and cathodic protection. In addition, this document provides a corrosion control requirements matrix based on varied soil conditions and other factors related to expected corrosivity for buried large diameter metallic pipes to be installed by the City of Phoenix in the future. This matrix has been closely coordinated with the Corrosion Protection Method Evaluation report previously received and accepted by the Water Services Department.

The first step in using the Corrosion Control requirements matrix is to have the pertinent soils tested for soil corrosivity parameters. These parameters should include the following:

- Resistivity (ohm-cm) – do both Wenner 4-Pin and saturated soil box tests.
- Soil Moisture Content (Percentage)
- Redox Potential (mV)
- Chloride Ion Concentration (ppm) in soil or ground water
- Sulfate Ion Concentration (ppm) in soil or ground water
- The presence of sulfides (positive or negative)
- Will new pipe be exposed to ground water constantly or intermittently? Will or could this change in the future?
- pH – of soil and ground water
- Will new pipe cross or parallel source of possible DC current leakage?

These tests and evaluations should be performed at least once for every 2,500 LF of the proposed pipeline route and more often should soil conditions vary widely. For instance, if the new pipe will cross a water course or river bed or pass through an agricultural run-off area, landfill, or old industrial site, more frequent sampling and analysis should be conducted to ensure that potentially more aggressive conditions are identified and documented. Once all of this data has been reported, informed decisions can be made regarding corrosion protection method requirements. Making the right corrosion protection method decisions should follow this sequence:

Corrosion Protection Design Standards Development Report
For Large Diameter Ductile Iron, Steel, CCP and RCP
Water Transmission Pipelines
Prepared for: The City of Phoenix – Water Services Department

Prepared by: Brown and Caldwell
and Corrosion Probe, Inc.
15 September 2012
Page 1

2.0 CORROSION ASSESSMENT GRADING FOR SELECTING CORROSION PROTECTION METHODS

Various soil conditions and other exposure conditions such as stray current effects, and pipe connections to other metallic structures or pipelines are known to affect the corrosivity or potential corrosivity of soils and pipes buried in soils. Below a description of various levels of corrosivity for large diameter pipelines (non PCCP) is presented for use with the Corrosion Protection Matrix (presented herein) for selecting specific corrosion protection methods for various pipe materials for specific projects.

METALLIC PIPE: STEEL AND DUCTILE IRON

Aggressively Corrosive:

- Soil resistivity is less than 500 ohm-cm.
- Soil is shown to be high in chloride ion concentration (> 300 ppm) or pH is below 5.5.
- Soil resistivity is above 2,000 ohm-cm, but shows the presence of sulfides, has anaerobic conditions conducive to the biological activity of sulfate reducing bacteria, and has a lower or negative redox potential (negative to +100 mV) and/or has a water table condition in which the pipeline invert will be intermittently or continually within the ground water.
- The new pipe will run parallel to or cross a DC current transit system track or other pipeline that is protected by an impressed current cathodic protection system where stray current leakage is possible.
- The new pipe crosses or parallels a large high voltage overhead or buried cable AC traction/transmission system.

Moderately Corrosive:

- Soil resistivity is 1,000 to 2,000 ohm-cm.
- Soil resistivity is between 2,000 and 3,000 ohm-cm and there is no evidence of sulfides, sulfate reducing bacterial redox potential is above +100 mV, and the water table is typically below new pipe invert elevation.
- Pipe does not parallel or cross DC current sources such as transit systems or other pipelines protected with impressed current cathodic protection systems.

Corrosion Protection Design Standards Development Report
For Large Diameter Ductile Iron, Steel, CCP and RCP
Water Transmission Pipelines
Prepared for: The City of Phoenix – Water Services Department

Prepared by: Brown and Caldwell
and Corrosion Probe, Inc.
15 September 2012
Page 3

- Soil resistivity is above 2,000 ohm-cm, but pipe will be exposed to fluctuating ground water levels annually.

Potentially Corrosive:

- Soil resistivity is 2,000 to 10,000 ohm-cm.
- New pipeline will pass through an area where future DC current transit system may be expanded or where a new gas or oil transmission pipelines to be cathodically protected with ICCP are planned in the future.
- New pipeline may be exposed to high ground water in the future due to changes in drainage in an area.

Non-Corrosive:

- Soil resistivities are 10,000 ohm-cm or greater.
- Pipeline is not near existing cathodically protected pipelines (with ICCP) or DC current transit systems or large AC transmission systems.
- Soil shows no evidence of anaerobic biological activity and water table is well below buried pipe elevation all year round.

**CORROSIVITY ASSESSMENT GRADING FOR SELECTING
CORROSION PROTECTION METHODS**

CONCRETE CYLINDER PIPE (CCP) AND REINFORCED CONCRETE PIPE (RCP)

Aggressively or Moderately Corrosive:

- Soils or ground water have pH of 5.5 or lower.
- Soils or ground water have sulfate concentrations of 2,000 ppm or higher.
- Soils or ground water have chloride concentrations of 150 ppm or higher and ground water will be present and ground water levels will fluctuate.
- Soils have chloride ion concentrations of 300 ppm or greater and soils have <20% moisture content and/or ground water is not present at pipe burial depth.
- Buried pipeline will be crossing or parallel to ICCP protected existing pipelines or DC current transit systems where DC stray current leakage could cause corrosion.

Potentially Corrosive:

- Soil or ground water have a pH of higher than 5.5, but the pH could become lower in the future due to industrial or agricultural effects on the environment.
- Soil or ground water have sulfate concentrations of less than 2,000 ppm, but concentration effects could increase those concentrations over time.
- Soil or ground water chloride ion concentrations are below 150 ppm, but could increase due to concentration effects over time and fluctuating ground water fluctuation is expected.
- Future plans call for expansion of the DC transit rail system or the installation of a new pipeline to be protected by ICCP in the path of the subject pipeline.

Non-Corrosive:

- No ground water will be present at buried pipe elevation.
- Soil pH will be 7.0 or higher.

Corrosion Protection Design Standards Development Report
For Large Diameter Ductile Iron, Steel, CCP and RCP
Water Transmission Pipelines
Prepared for: The City of Phoenix – Water Services Department

Prepared by: Brown and Caldwell
and Corrosion Probe, Inc.
15 September 2012
Page 5

- Soil sulfate concentrations will be less than 1,000 ppm and soil moisture content will be less than 20%.
- Soil chloride concentrations will be 150 ppm or less and soil moisture content will be <20%.
- New pipeline will not cross or parallel DC transit rail systems or other pipelines protected with ICCP.

Corrosion Protection Design Standards Development Report
For Large Diameter Ductile Iron, Steel, CCP and RCP
Water Transmission Pipelines
Prepared for: The City of Phoenix – Water Services Department

Prepared by: Brown and Caldwell
and Corrosion Probe, Inc.
15 September 2012
Page 6

3.0 CORROSION PROTECTION METHODS MATRICES

Corrosion Protection Design Standards Development Report
For Large Diameter Ductile Iron, Steel, CCP and RCP
Water Transmission Pipelines
Prepared for: The City of Phoenix – Water Services Department

Prepared by: Brown and Caldwell
and Corrosion Probe, Inc.
15 September 2012
Page 7

CORROSION PROTECTION METHOD MATRICES

CORROSION ASSESSMENT GRADE

Pipe Material	Aggressively Corrosive	Moderately Corrosive	Potentially Corrosive (Future)	Non-Corrosive
Ductile Iron	ICCP or galvanic cathodic protection and/or polyethylene encasement. Note 1	ICCP or galvanic cathodic protection and/or polyethylene encasement. Note 1	Bond pipe joints. Isolate as required. Install test stations and monitor and consider polyethylene encasement also.	Polyethylene encasement only.
Steel	Bonded pipeline coating and galvanic cathodic protection or ICCP. Notes 1, 2	Bonded pipeline coating and galvanic cathodic protection or ICCP. Notes 1, 2	Bonded pipeline coating and galvanic cathodic protection or ICCP. Notes 1, 2,	Bonded coating or tape coating systems or cement mortar coating and cathodic protection connections and test stations. Monitor in future. Notes 1, 2, 4
Concrete Cylinder Pipe (CCP) 3	DO NOT USE Or if other materials not appropriate, protect with external coating plus polyethylene encasement and bond all joints and install test stations for monitoring. And use improved cement mortar coating mix design and install galvanic cathodic protection.	DO NOT USE Or if other materials not appropriate, protect with external coating plus polyethylene encasement and bond all joints and install test stations for monitoring. And use improved cement mortar coating mix design and install galvanic cathodic protection.	DO NOT USE Or if other materials not appropriate, protect with external coating plus polyethylene encasement and bond all joints and install test stations for monitoring. And use improved cement mortar coating mix design. Galvanic cathodic protection can be installed in the future if needed.	Rely on cement mortar coating. Improve mix design. Possibly include polyethylene encasement.
ICCP = Impressed Current Cathodic Protection				

Corrosion Protection Design Standards Development Report
For Large Diameter Ductile Iron, Steel, CCP and RCP
Water Transmission Pipelines
Prepared for: The City of Phoenix – Water Services Department

Prepared by: Brown and Caldwell
and Corrosion Probe, Inc.
15 September 2012
Page 8

Pipe Material	Aggressively Corrosive	Moderately Corrosive	Potentially Corrosive (Future)	Non-Corrosive
Reinforced Concrete Pipe (RCP) Cylinder Type 3	DO NOT USE Or if other materials not appropriate, protect with external coating plus polyethylene encasement and bond all joints and install test stations for monitoring. And use improved cement mortar coating mix design and install galvanic cathodic protection.	DO NOT USE Or if other materials not appropriate, protect with external coating plus polyethylene encasement and bond all joints and install test stations for monitoring. And use improved cement mortar coating mix design and install galvanic cathodic protection.	DO NOT USE Or if other materials not appropriate, protect with external coating plus polyethylene encasement and bond all joints and install test stations for monitoring. And use improved cement mortar coating mix design.	Use as is. No special treatment required.
Reinforced Concrete Pipe (RCP) Non-Cylinder Type 3	DO NOT USE Unless compelling structural or hydraulic reasons not to use other materials. If used, rely on improved mix design for concrete and include exterior protective coating and polyethylene encasement. Do not bond joints or consider cathodic protection.	DO NOT USE Unless compelling structural or hydraulic reasons not to use other materials. If used, rely on improved mix design for concrete and include exterior protective coating and polyethylene encasement. Do not bond joints or consider cathodic protection.	DO NOT USE Unless compelling structural or hydraulic reasons not to use other materials. If used, rely on improved mix design for concrete and include exterior protective coating and polyethylene encasement. Do not bond joints or consider cathodic protection.	Use as is. No special treatment required.

1. The decision to use galvanic cathodic protection vs. ICCP is based on the parameters given in Part 4.0 of this Corrosion Protection Design Standards Report.
2. The choice of bonded pipe coatings is given in Part 4.0 of this Corrosion Protection Design Standards Report.
3. Improvement recommendations for cement mortar coatings and concrete for CCP and RCP are provided in Part 5.0 of this report.
4. Cement mortar coatings alone should never be used when the soil or ground water pH is below 5.5 or where chloride concentrations are above 150 ppm.

Corrosion Protection Design Standards Development Report
For Large Diameter Ductile Iron, Steel, CCP and RCP
Water Transmission Pipelines
Prepared for: The City of Phoenix – Water Services Department

Prepared by: Brown and Caldwell
and Corrosion Probe, Inc.
15 September 2012
Page 9

4.0 MAJOR CORROSION PROTECTION OPTIONS BY LARGE DIAMETER PIPE MATERIAL OF CONSTRUCTION – BACKGROUND INFORMATION

4.1 Ductile Iron Pipe

Corrosion Protection options include:

- Polyethylene Encasement in accordance with AWWA C105 1A21.5.
- Protective Coatings (however, the DI pipe manufacturers in the United States will not condone the use of coatings. Indian DI pipe manufacturers provide DI pipe with well bonded external coating systems.)

The only external coating system for DI pipe approved by the United States DI Pipe Manufacturers for push-on joint piping is the 1 mil thick bituminous coating specified in AWWA C151. This coating does virtually nothing to prevent external pipe corrosion once pipe is buried. However, these same manufacturers support the use of petrolatum based tape wrapping of buried flanged joints in DI pipe.

In the future, it is believed that the DI pipe industry will adopt the use of bonded dielectric coatings for corrosion protection of the exterior of DI pipe and fittings.

- Sacrificial or galvanic cathodic protection which requires electrical bonding across all pipe joints, electrical isolation of above ground piping that is connected, electrical bonding at restraint couplings, and the installation of test stations provides excellent corrosion protection where soils are more aggressive or will become aggressive over time.

Today, most large water utilities in the United States including the City of Phoenix require electrical bonding of all pipe joints for DI pipelines which are 16 inches or larger in diameter. This permits the option of either monitoring pipe to soil potentials in the future such that cathodic protection can be easily installed later or cathodic protection can be provided during installation.

- Impressed Current Cathodic Protection (ICCP): The major components of ICCP systems are the rectifier power unit, the anode groundbed and the cables and junction boxes connecting the components to the structure to be protected.

Corrosion Protection Design Standards Development Report
For Large Diameter Ductile Iron, Steel, CCP and RCP
Water Transmission Pipelines
Prepared for: The City of Phoenix – Water Services Department

Prepared by: Brown and Caldwell
and Corrosion Probe, Inc.
15 September 2012
Page 10

Rectifiers are the power source for ICCP and these must be maintained and monitored to ensure the systems are operating as designed. Transformer rectifiers convert AC power to lower voltage direct current. For pipelines, most rectifiers are set at a constant output voltage setting and the current output varies based on the conditions in the ground, including moisture level due to precipitation. The DC negative output circuit is connected by black cables to the pipe and the DC positive circuit is connected by red cables to an anode circuit which normally includes a multi-circuit junction box that allows measuring individual anode currents. The anodes are made from alloys that can discharge currents while remaining dimensionally stable and operational for over 20 years. Common anode types are high silicon tubular cast iron, mixed metal oxide tubular and graphite rod type anodes. The buried DC positive cable circuit is vulnerable to excavation damage and must be protected and marked and sometimes backfilled with colored Controlled Low-Strength Material (CLSM). Anode groundbed configuration can be either distributed in multiple shallow (20 ft deep) excavations or arranged vertically in a deep 12-inch diameter hole up to 300 feet deep. ICCP requires electrical bonding across all pipe joints, electrical isolation of above ground piping that is connected, electrical bonding at restraint couplings, and the installation of test stations provides excellent corrosion protection where soils are more aggressive or will become aggressive over time.

Today, most large water utilities in the United States including the City of Phoenix require electrical bonding of all pipe joints for DI pipelines which are 16 inches or larger in diameter. This permits the option of either monitoring pipe to soil potentials in the future such that cathodic protection can be easily installed later or cathodic protection can be provided during installation.

- If Stray Current exposure is deemed likely, special cathodic protection provisions, special test station measures, and other factors used to be considered. Refer to 3.6 of this document.

4.2 Steel Pipe

Carbon steel pipe corrosion protection includes the following options:

- Protective Coatings which are well bonded and provide good film quality to isolate the pipe surfaces from the soil environment provide very good corrosion protection except at pinholes, holidays, or small breach areas on the pipe's surfaces due to mechanical damage during handling, installation, and backfilling, etc.

Coating systems for the exterior of steel pipe typically include the following:

- Polyurethane coatings applied in accordance with AWWA C222.
- Liquid applied epoxy coatings applied in accordance with AWWA C210.
- Fusion bonded epoxy coatings applied in accordance with AWWA C213.

The City of Phoenix specifications currently recognize only the polyurethane coating option or tape coatings in accordance with AWWA C209 and C214.

- Polyethylene and PVC Tape Wrapping is also an option that provides good isolation type barrier protection. Tape wrapping is typically utilized in conjunction with liquid applied protective coating primers.

Prefabricated, cold applied multi-layer pipeline tape coating systems generally consist of polyethylene tape systems which include heat shrinkable sleeves for fittings.

Polyolefin Tape Wrapping Systems are also available for external steel pipe protection and are specified in accordance with AWWA C209.

- Petrolatum or Wax Tape Wrapping are alternative tape wrap materials which provide good barrier protection to steel pipe and are typically used either with protective coatings or where high quality surface preparation cannot be performed due to the presence of ground water or where poor weather conditions prevail or where urban location prevents such work.
- Cement mortar coatings for the exterior of steel pipe provide good alkaline maintenance of the natural passive protection of steel pipe. The cement mortar coating keeps the steel in a high pH environment in which under non-aggressive soils corrosion is not initiated. Cement mortar coatings also provide a hard, abrasion resistant skin on the pipe during backfilling and can help prevent damage (“Rock Guard”) to other corrosion resistant coatings applied beneath the cement mortar coating. Cement mortar coatings alone are a viable option for steel pipe corrosion protection where soils are non-aggressive.

Cement mortar coatings are also beneficial in that they provide stiffening of steel pipe for handling, transporting, and installation. Cement mortar coatings are covered in AWWA C205-07. Where cement mortar coatings are to be used alone for steel pipe corrosion protection, the cement mortar mix design should be improved by one of several ways:

Corrosion Protection Design Standards Development Report
For Large Diameter Ductile Iron, Steel, CCP and RCP
Water Transmission Pipelines
Prepared for: The City of Phoenix – Water Services Department

Prepared by: Brown and Caldwell
and Corrosion Probe, Inc.
15 September 2012
Page 12

- Use a lower water to cement ratio, but not so low that workability is adversely affected. Consider using a super plasticizer or high range water reducer for this purpose as the workability can be increased without so much water. Start with a water to cementitious materials ratio of 0.40 and use the super plasticizer to increase workability.
- Add pozzolans in the mix design such as Type F fly ash and Type II Portland cement to enhance sulfate resistance of cement mortar coatings.
- Consider the use of corrosion inhibitors such as calcium nitrite in the mix design for the cement mortar coating.

If and when cement mortar coatings are to be used as armor protection for dielectric bonded coatings, “mortar diapers” will need to be installed where such cathodically protected systems terminate at buried isolation joints.

- Galvanic or sacrificial cathodic protection is invariably used for steel pipe corrosion protection in concert with well bonded protective coatings. This combination is the most common and most successful approach for steel pipe corrosion protection because the high quality coating systems do most of the work while the cathodic protection current prevents localized, accelerated corrosion at any small breaks or holidays in the coating. The great advantage with this method is the cost of the cathodic protection is very low for a long timeframe as very little current density is required due to so little bare steel surface area. Hence, the depletion rate of the sacrificial anodes is very low providing protection for many years. Sacrificial cathode protection requires the installation of test stations, bonding across any joints where electrical continuity is in question (not often with welded steel pipe), and electrical isolation of connected above-ground piping. Also, special considerations need to be given to the design where the risk of exposure to stray current is deemed likely.
- Impressed Current Cathodic Protection (ICCP) is also a very viable corrosion protection method for steel pipe similarly for DI pipe as described in 2.1 above. ICCP is generally selected in lieu of galvanic CP when the following conditions exist:
 - Corrosion protection is needed where soil resistivities along the pipeline vary widely with areas of very high resistivity.
 - Areas where soil resistivity is very high, but stray current exchange is expected to cause pipe corrosion.

- The pipe system to be protected is connected to a lot of branch piping or above-ground piping and electrical isolation is very difficult or cost prohibitive.
- Where current requirements are quite high and AC power can be used and installed efficiently.
- Where current requirements are relatively high due to a poorly coated pipeline.
- Where limited access in a right-of-way results in many miles of pipe can be protected with a single ICCP system.

Galvanic or Sacrificial Cathodic Protection Systems are used when:

- Structures with relatively low current requirements are necessary such as for well coated pipelines.
- Right-of-way anodes can be installed in areas of low soil resistivity to optimize current output per anode.
- Pipeline is in a remote area where external power sources are not available.
- Where the low maintenance advantage of galvanic systems is desired.
- Where in close proximity to other pipes or structures where minimizing stray current from our pipeline on those other structures is desirable.

The downsides to ICCP over Sacrificial CP are higher initial costs, higher energy costs over time, and they are far more maintenance and operation intensive. Also, the rectifier and associated equipment has to be installed somewhere at which it can be protected and maintained.

- Stray Current Mitigation, where deemed necessary, requires special measures. See Part 3.6 of this document.
- Properly installed – bonded pipeline coatings along with supplemental cathodic protection comprise the best method for corrosion protection of steel pipelines for corrosive soils and where stray current is a problem. The bonded pipeline coatings can include the following:
 - Liquid Applied Epoxy Coatings – AWWA C210.

- Coal-Tar Enamel and Wrap – AWWA C203.
- Cold Applied Tape Systems – AWWA C209.
- Mill Applied Tape Systems – AWWA C214.
- Polyurethane Coatings – AWWA C222.
- Extruded Polyolefin Coatings – AWWA C215.

4.3 Concrete Cylinder Pipe (CCP) for Pressure Service

This pipe consists of a welded steel cylinder with sized steel rings welded to its ends, and internal concrete or cement mortar lining that is centrifugally applied and joint rings, and a dense cement mortar coating over its exterior non-prestressed reinforcement. The steel rod reinforcement is continuous and is tightly wound helically around the outside of the steel cylinder. This reinforcement is also welded to the steel joint rings.

This pipe is required to be manufactured in accordance with AWWA C303.

Corrosion Protection methods for CCP generally consist of one of three options:

- Reliance on the cement mortar coating. In this case, the mortar mix design including cement type and water to cementitious materials ratio can be modified to improve resistance to sulfate reactions and chloride ion prevention. Cement mortar coatings should not be relied upon when soil conditions are acidic having a pH of 5.5 or lower.
- The application of coal – tar epoxy coatings on the exterior of the CCP.
- The installation of a sacrificial or galvanic cathodic protection system provided good electrical continuity is provided for the reinforcing steel, the steel cylinder, and the joints. Joint bonding should always be required at all CCP joints. This is typically achieved via steel bonding clips welded to the joint rings during installation. A minimum of two bonding clips is required at each joint. Ensuring electrical continuity gives the owner the option of installing cathodic protection initially or later following monitoring of the pipeline. The use of cathodic protection would apply to stray current areas as well as high chloride areas of soil. However, cathodic protection will not mitigate sulfate attack or acidic attack of concrete pipe.

4.4 Reinforced Concrete Pipe or RCP (For Gravity or Low Pressure Service) consist of conventionally reinforced concrete with or without an inner welded steel cylinder. RCP should conform to AWWA C300 or C302 respectively. Like CCP, RCP is vulnerable to three types of corrosive attack including acidic attack, chloride ion intrusion, or sulfate reactions. Corrosion protection for RCP includes the use of improved concrete mix designs such as the use of Type V Portland Cement for improved sulfate resistance or lower water to cementitious materials ratios to reduce permeation rates by chlorides. Alternatively, coal tar epoxy coatings can be applied to the exterior of the RCP. Another option is the use of corrosion inhibitors such as calcium nitrate in the concrete mix design to inhibit the corrosion of the reinforcing steel. Also, epoxy coated reinforcing steel can be considered depending on the soil conditions.

The use of cathodic protection would be unusual for RCP due to concerns over electrical continuity in the reinforcing steel.

5.0 RECOMMENDATIONS FOR CORROSION PROTECTION METHODS FOR LARGE DIAMETER PIPE BY MATERIALS OF CONSTRUCTION

5.1 Key Consideration Factors

When evaluating the recommendations for corrosion protection methods for each major pipe material of construction for this project, we have considered the following key factors affecting corrosion of each specific pipe material:

A. Soil Corrosivity for Ferrous Metal

Piping including ductile iron and steel pipe involved the evaluation of several soil parameters including resistivity, soil chemistry parameters such as soluble salt concentrations e.g. chlorides and sulfates, redox potential, the present and location of ground water, soil pH, the presence of sulfides, and other factors. Some of the other factors include soil stratification, soil contamination from external sources, and soil type, etc.

Ductile iron and steel pipe will corrode electrolytically based on those soil parameters, galvanically if electrically connected to more noble metals, or due to microbiologically influenced corrosion (MIC).

In addition, metallic pipes will corrode due to stray current effects when stray current leaves these pipeline surfaces.

B. Soil Chemistry Effects on Concrete Pipe Materials including CCP and RCP are also an important consideration. High chloride concentrations and sulfate concentrations in ground water and soil cause degradation of concrete pipe materials. Chloride intrusion through concrete or cement mortar coatings cause depassivation of reinforcing steel and promote higher corrosion rates by raising conductivity while high sulfates cause sulfate reactions with the concrete causing expansive deterioration of the hydrated cement paste. Also, acidic soils cause acidic breakdown of the alkaline cement paste and promote reinforcing steel corrosion in concrete pipe materials.

C. Stray Current Corrosion Risks are a significant consideration for large diameter water transmission pipelines especially where cities like Phoenix have a light rail commuter train system that operates on DC current. Stray current corrosion can be problematic for both metallic and concrete piping materials. See Part 3.6 of this document.

5.2 Ductile Iron Pipe Corrosion Protection

For large diameter ductile iron pipelines, one of two options is recommended:

- A. If the soil resistivity is below 2000 ohm-cm, the pipe should be electrically bonded and protected with cathodic protection. The use of galvanic cathodic protection versus impressed current cathodic protection based on other parameters are discussed in Parts 2.0 and 4.0 of this document. Also, refer to the Cathodic Protection Decision Trees in Appendix A to this document. In addition if the soil resistivity is above 2000 ohm-cm but shows the presence of sulfides, has anaerobic conditions conducive to the activity of sulfate reducing bacterial, has a lower or negative redox potential (negative to +100mv, and/or has a water table condition in which the pipeline invert will be intermittently or continually within ground water, the pipeline should be protected by cathodic protection.
- The use of cathodic protection will include the electrical bonding of all joints, the installation of test stations (typically one every 500 to 1,000 LF plus one at all major pipe crossings and to detect stray currents near light rail locations), electrical isolation where appropriate, and all other measures delineated in the cathodic protection standards for the City of Phoenix.
- B. If the soil resistivity is above 2000 ohm-cm and none of the other uniquely severe conditions defined above exist, the pipe should be electrically bonded at all joints as specified by the City of Phoenix standard specifications for ductile iron pipe and installed in all other ways as though cathodic protection will be installed in the future. This will allow monitoring of the pipeline and facilitate low cost ease of cathodic protection installation in the future.

The referenced standards for cathodic protection of metallic pipelines are:

- NACE SP0169 – Control of External Corrosion on Underground or Submerged Metallic Piping System.
- NACE SP0286 – Electrical Isolation of Cathodically Protected Pipelines.
- NACE TM0497 – Measurement Techniques Related to Criteria for Cathodic Protection on Underground or Submerged Metallic Piping Systems.

Corrosion Protection Design Standards Development Report
For Large Diameter Ductile Iron, Steel, CCP and RCP
Water Transmission Pipelines
Prepared for: The City of Phoenix – Water Services Department

Prepared by: Brown and Caldwell
and Corrosion Probe, Inc.
15 September 2012
Page 18

Cathodic Protection System Surveys for each pipeline should be performed once annually and should consist of the following activities:

- Inspect and test all galvanic anode CP test stations. Record individual anode current and open circuit potentials.
- Measure the structure-to-earth potentials to verify adequate levels of CP for the entire pipeline.
- Inspect and test all other CP test stations connected to the pipelines. Measure the structure-to-earth potentials. This includes test stations at other pipe crossings, etc. If an Impressed Current Cathodic Protection System (ICCP) is selected and installed, the monitoring program has to include the annual survey as outlined above plus a monthly survey as outlined below. The system rectifiers must be inspected and the CP technician or technologist must measure and record the ICCP rectifiers operating levels along with notes and observations of deficiencies, damage, or vandalism.

5.3 Steel Pipe Corrosion Protection

For large diameter steel pipelines, the following options are recommended:

- A. Under most soil conditions, the use of bonded pipeline coatings and supplemental cathodic protection is recommended for all large diameter steel pipelines.

The recommended bonded pipeline coating systems are:

Polyurethane coating per AWWA C222

or

Cold Applied Tape Systems per AWWA C214 for pipe and C209 for fittings

and

Heat shrinkable sleeves per AWWA C216

The selection of galvanic CP versus ICCP protection will be based on the factors discussed in Parts 2.0 and 4.0 of this document. Also, refer to the Cathodic Protection Decision Trees in Appendix A to this document.

The selection of which bonded pipeline coating system should be made based on the following factors:

- The system providing the best adhesion and resistance to damage by soil stress.
- If ICCP is used, the system with the best cathodic disbondment resistance should be chosen.
- The system with the best chemical and water permeation resistance for the soil conditions.
- Flexibility to resist cracking or breakage during handling, installation, and backfilling.
- The decision regarding which protective coating system is best should be made using the selection criteria and Decision Tree in Appendix B to this document.
- The use of cathodic protection will include the electrical bonding of all joints, the installation of test stations (typically one every 500 to 1,000 LF plus one at all major pipe crossings and to detect stray currents near light rail locations), electrical isolation where appropriate, and all other measures delineated in the cathodic protection standards for the City of Phoenix.

The referenced standards for cathodic protection of metallic pipelines are:

- NACE SP0169 – Control of External Corrosion on Underground or Submerged Metallic Piping System.
- NACE SP0286 – Electrical Isolation of Cathodically Protected Pipelines.
- NACE TM0497 – Measurement Techniques Related to Criteria for Cathodic Protection on Underground or Submerged Metallic Piping Systems.

Cathodic Protection System Surveys for each pipeline should be performed once annually and should consist of the following activities:

- Inspect and test all galvanic anode CP test stations. Record individual anode current and open circuit potentials.
- Measure the structure-to-earth potentials to verify adequate levels of CP for the entire pipeline.

Corrosion Protection Design Standards Development Report
For Large Diameter Ductile Iron, Steel, CCP and RCP
Water Transmission Pipelines
Prepared for: The City of Phoenix – Water Services Department

Prepared by: Brown and Caldwell
and Corrosion Probe, Inc.
15 September 2012
Page 20

- Inspect and test all other CP test stations connected to the pipelines. Measure the structure-to-earth potentials. This includes test stations at other pipe crossings, etc. If an Impressed Current Cathodic Protection System (ICCP) is selected and installed, the monitoring program has to include the annual survey as outlined above plus a monthly survey as outlined below. The system rectifiers must be inspected and the CP technician or technologist must measure and record the ICCP rectifiers operating levels along with notes and observations of deficiencies, damage, or vandalism.

5.4 Concrete Cylinder Pipe Corrosion Protection

The following corrosion protection methods are commended for CCP:

- A. Do not use CCP in soils having a pH of 5.5 or lower.
- B. Do not use CCP in soils having sulfate concentrations of 2000 ppm or higher.
- C. Do not use CCP in soils having about 300 ppm chloride concentrations and low moisture contents.
- D. Do not use CCP in soils where fluctuating ground water conditions exist and chloride ion concentrations are as low as 150 ppm.
- E. If any of the conditions given above in items A., B., C., or D. and other pipeline materials do not seem appropriate, consider using CCP with an exterior protective coal tar epoxy coating plus a protective polyethylene encasement. In addition if sulfate levels are high, be certain Type V Portland Cement plus pozzolanic fly ash supplemental cementing materials are used in the concrete mix design for the pipe. Also, a low water to cementitious materials ratio (less than 0.40) should be used.
- F. Be certain to bond all joints with bonding clips despite the soil conditions for all CCP installations such that the pipeline is electrically continuous. This will permit future monitoring. This also requires that test stations be installed at least every 1000 LF and at all major pipe crossings as well.
- G. If none of the conditions described above exist, the use of CCP is recommended with no special treatment with the exception of bonding for future monitoring.

The referenced standards for CCP are as follows:

- AWWA C303 – Concrete Pressure Pipe – Bar Wrapped, Steel Cylinder Type.
- AWWA Manual M9 – Concrete Pressure Pipe.
- NACE SP0169 – Control of External Corrosion of Underground or Submerged Metallic Piping Systems.

Monitoring corrosion of CCP pipelines includes annual inspection and testing at all test stations to perform pipe to soil potentials including foreign pipe crossing test stations.

5.5 Reinforced Concrete Pipe Corrosion Protection

The following corrosion protection methods are recommended for RCP.

- A. Do not use RCP in soils having a pH of 5.5 or lower.
- B. Do not use RCP in soils having sulfate concentrations of 2000 ppm or higher.
- C. Do not use RCP in soils having about 300 ppm chloride concentrations and low moisture contents.
- D. Do not use RCP in soils where fluctuating ground water conditions exist and chloride ion concentrations are as low as 150 ppm.
- E. If any of the conditions given above in items A., B., C., or D. and other pipeline materials do not seem appropriate, consider using RCP with an exterior protective coal tar epoxy coating plus a protective polyethylene encasement. In addition if sulfate levels are high, be certain Type V Portland Cement plus pozzolanic fly ash supplemental cementing materials are used in the concrete mix design for the pipe. Also, a low water to cementitious materials ratio (less than 0.40) should be used.
- F. If the RCP has a steel cylinder, be certain to bond all joints with bonding clips despite the soil conditions for all RCP installations such that the pipeline is electrically continuous. This will permit future monitoring. This also requires that test stations be installed at least every 1000 LF and at all major pipe crossings as well.

- G. If it is RCP with no cylinder, electrical bonding is neither practical nor necessary. This applied to RCP conforming to AWWA C302. If none of the conditions described above exist, the use of RCP is recommended with no special treatment.

The referenced standards for RCP are as follows:

- AWWA C300 – Reinforced Concrete Pressure Pipe – Steel Cylinder Type.
- AWWA C302 – Concrete Pressure Pipe, Non Cylinder Type for Water and Other Liquids.
- AWWA Manual M9 – Concrete Pressure Pipe.

Monitoring corrosion of RCP pipelines includes annual inspection and testing at all test stations to perform pipe to soil potentials including foreign pipe crossing test stations.

5.6 Stray Current Mitigation

Stray current, which is current through paths other than the intended circuit, can cause corrosion problems. Electrical Interference is any electrical disturbance on a metallic structure in contact with an electrolyte caused by stray current(s). When occurring together, Stray Current and Electrical Interference is often referred to as Stray Current Interference (SCI).

Corrosion of metal water pipes can be exacerbated by SCI. Susceptible pipe materials include ductile iron pipe (DIP), cast iron pipe (CIP), concrete pipe with steel linings (PCCP) and welded metal pipe. When the conditions are suitable for SCI and mitigation factors are not employed then you can have accelerated corrosion of buried metallic structures.

Stray current occasionally has been designated as the cause of corrosion when another cause is not readily apparent. However, verification is fairly easily accomplished by trained CP experts.

NEW PIPELINES

When designing a metallic pipeline, the corrosion control design must consider stray current affects from surrounding sources of DC current. Sources of DC current include ICCP systems on other pipelines or structures and DC traction transit systems. Mitigation methods include the following:

- Design corrosion control using a combination of protective coatings and cathodic protection.
- Route the new pipeline such that it is not near anode groundbeds of foreign ICCP systems.
- Provide adequate space between the new pipe and existing foreign pipelines.
- Install four wire CP test stations on both pipelines at the crossing point.
- Install a dielectric blanket between pipelines at the crossing point.
- During pipeline commissioning, perform testing to evaluate the level of current exchange between existing ICCP systems and the new pipeline.

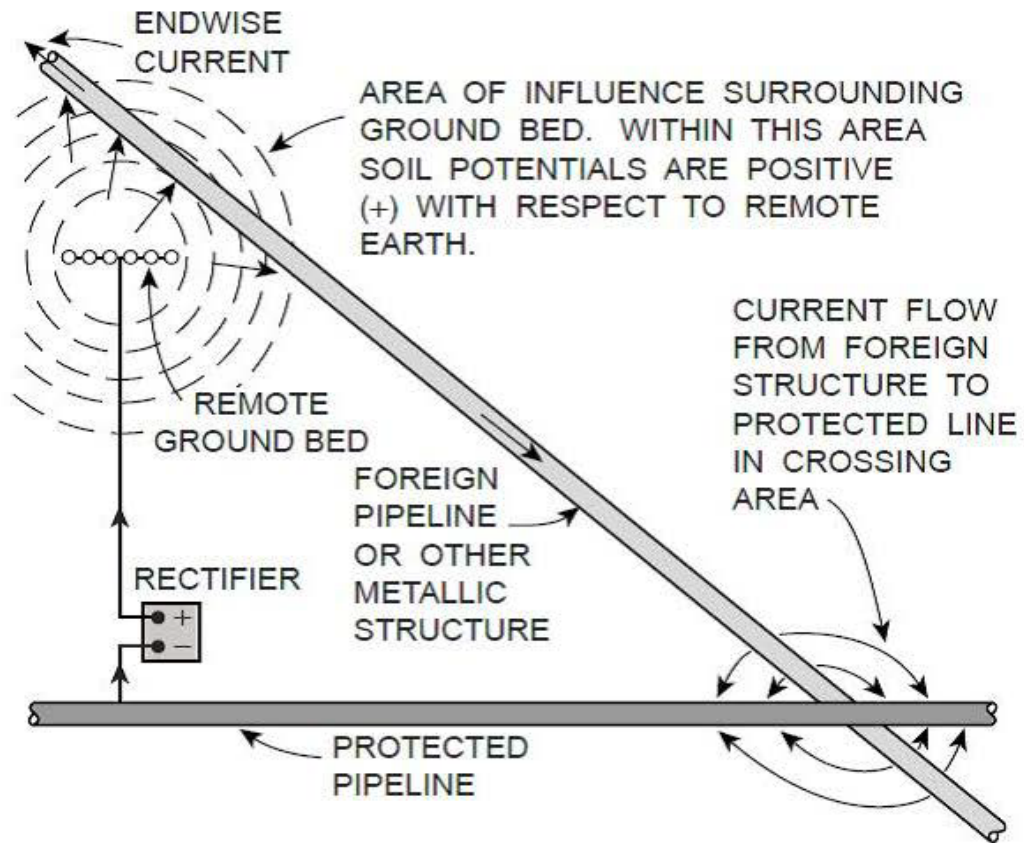

Figure 1 Stray Current Interference from Peabody's Control of Pipeline Corrosion

NEW ICCP AND DC TRACTION POWER SYSTEMS

Stray current on other buried utilities and structures should be considered as a part of the design and operation of CP system and traction power transit systems. Design features to minimize the risk of stray current interference including carefully selecting anode bed location and installing additional CP test stations at the crossing points. For traction power systems, the track-to-earth resistance should be maintained above a set minimum. In Phoenix, AZ, track-to-earth resistance is in the agreement that granted the transit authority the track right-of-way.

The high voltage overhead transmission wires can induce AC corrosion on buried structures. Buried AC lines cause AC corrosion less frequently.

AC induced corrosion by high voltage overhead transmission wires is less common and requires more specialized design and testing. Many papers on the topic are published by NACE International. Pipeline AC voltage must be kept below 15 VAC to prevent touch shock hazard and sometimes this requires professional technical design and testing. AC induced corrosion phenomenon is strongly correlated with lower soil resistivity along with increased pipeline AC voltage. Research has indicated that AC induced corrosion can occur when conditions are right and the pipe AC potential is below 15 VAC.

Appendices

The appendices will include the Decision Trees for coatings and cathodic protection systems, standard protective coatings, tape wrap, cathodic protection specifications, and the standard drawings.

Corrosion Protection Design Standards Development Report
For Large Diameter Ductile Iron, Steel, CCP and RCP
Water Transmission Pipelines
Prepared for: The City of Phoenix – Water Services Department

Prepared by: Brown and Caldwell
and Corrosion Probe, Inc.
15 September 2012
Page 27

APPENDIX A

Cathodic Protection

Decision Trees

DECISION TREE STEEL PIPE

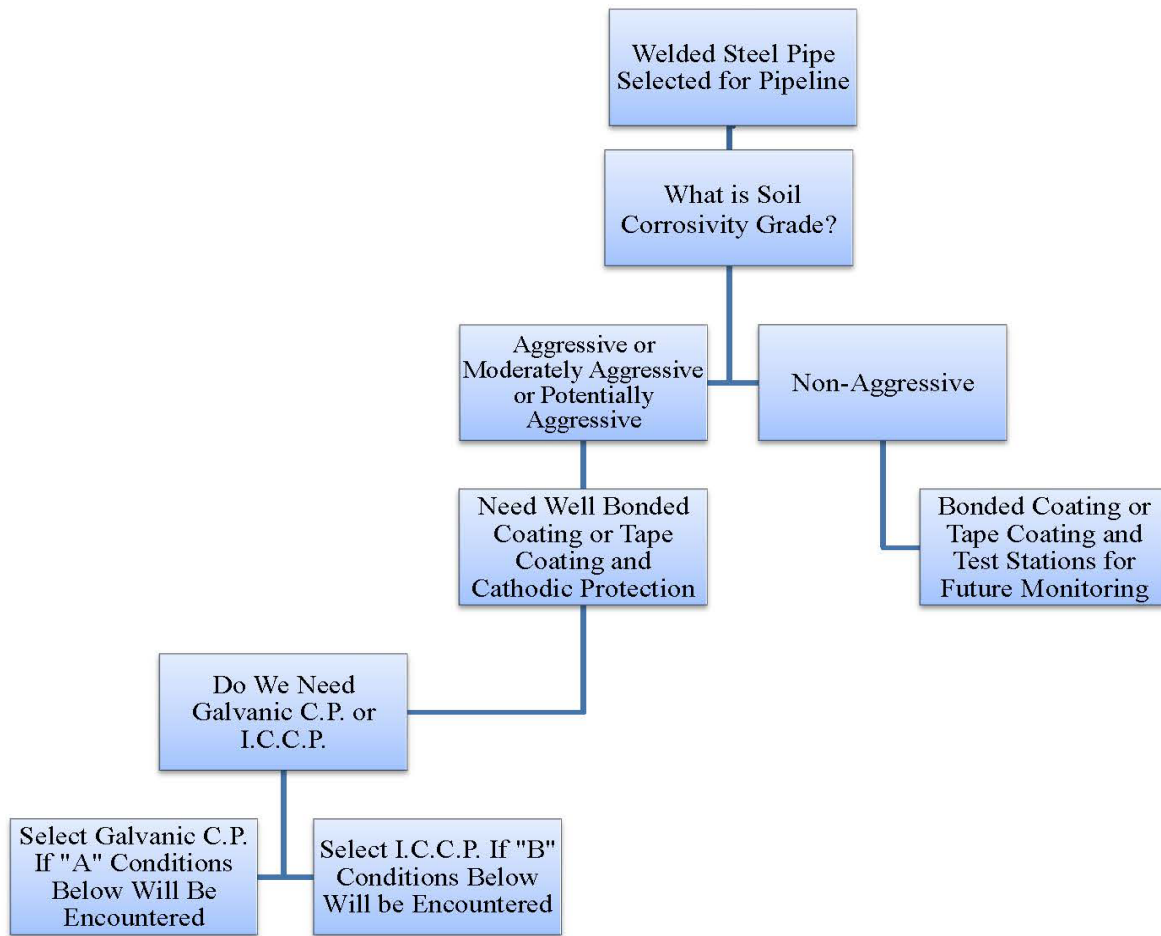

In all cases where C.P. is provided, proper electrical isolation of structures not to be protected and good electrical continuity along the pipeline to be protected must be ensured.

DECISION TREE DUCTILE IRON PIPE

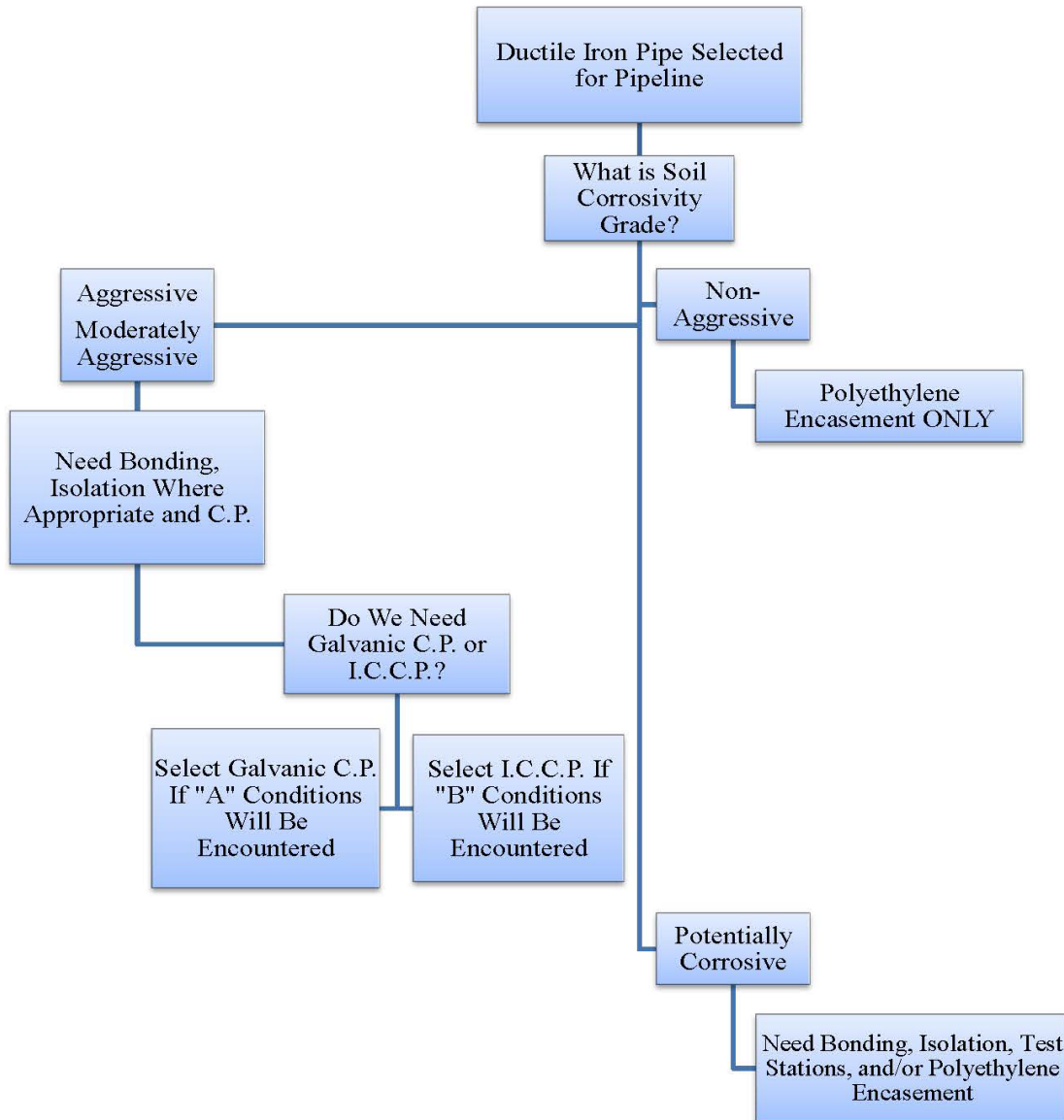

If C.P. is needed for DIP, all joints must be bonded, proper isolation of structures not to be protected must occur, and test stations will be necessary.

“A” Conditions

(*critical initial factors)

- *Pipeline will have relatively low cathodic protection current requirements such as where the pipe will be well coated. (Generally less than 0.5 ampere per mile of pipeline.)
- *Soil resistivities are relatively low and mostly consistent.
- Pipeline will be in a remote area where access to AC power source is not present or difficult and expensive to achieve. (Again provided current requirement is low.)
- Access to the pipeline for cathodic protection system upkeep and maintenance will be difficult due to urban congestion, hazardous conditions (traffic), or due to remote location.
- There are adjacent pipelines and buried structures in the path of the proposed pipeline and we want to minimize stray current effects on those other pipelines or structures.
- Anodes for right of ways can be installed in low resistivity soil to optimize current output.
- There will be minimal easement or right of way space such that anode placement is best accomplished close to the pipe.
- Where cathodic protection system monitoring costs need to be minimized, (rectifier and power monitoring costs are higher for I.C.C.P.) Galvanic cathodic protection systems require less frequent monitoring than I.C.C.P. systems.
- Survey costs for galvanic systems are lower as they can be performed on an annual basis.
- Where concerns regarding security and vandalism of AC power sources, rectifiers, and junction boxes are significant.

“B” Conditions

(*critical initial factors)

- *Pipeline will have relatively high cathodic protection current requirements (greater than 2 amperes for every mile of pipeline) such as where soil resistivity is high or where a pipeline will be poorly coated (poorly coated pipe is not recommended). If the current requirements are between 0.5 and 2 amperes per miles of pipeline, consider the other factors described herein.
- *Soil resistivities are high along the pipeline. These higher resistivities result in less current output per anode for galvanic cathodic protection systems.
- Pipeline will be installed along a path in which right of way access is limited and several miles of pipe can be protected with one I.C.C.P. system.
- Pipeline will be built where good access to AC power is present and can be installed economically.
- On large, long pipeline projects where one I.C.C.P. system can provide protection and numerous anode installations for galvanic cathodic protection systems would result in higher overall project costs.
- There is ample right of way or easement access for the installation of anode ground beds. For example, deep anodes could be installed 50 to 100 feet away from the pipeline.
- Access for pipeline and cathodic protection system upkeep and monitoring, i.e. test stations, rectifiers, junction boxes, and cathodic protection test stations is good.
- There are no or very few adjacent pipelines or structures present so concerns about stray current leakage are low.
- Cathodic protection system components can be installed where security is not a problem.
- The pipeline will be connected to non-electrically isolated structures such as above ground piping and equipment in pump stations or other reinforced concrete structures or to buried grounding mats, etc.
- The pipeline will be built where multiple anode installation costs are too high because of difficult excavation conditions or soil conditions for drilling.
- The pipeline to be protected will have changing current requirements which can exceed the output of sacrificial anodes.

**DECISION TREE
CONCRETE CYLINDER PIPE**

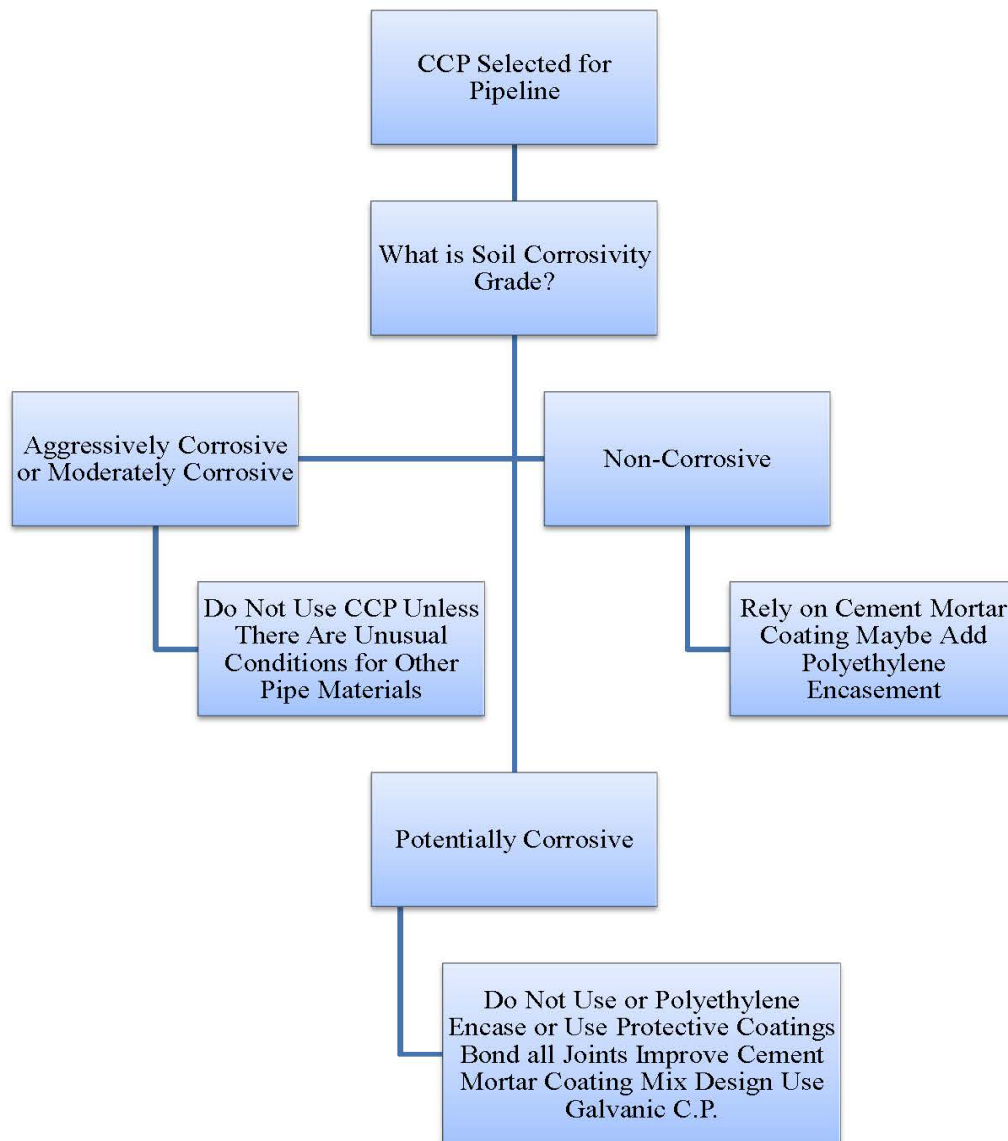

Note 1 – Here I.C.C.P would not be considered.

Note 2 – C.P. is generally not recommended for RCP except as noted in the Matrix. I.C.C.P. is not used for RCP.

APPENDIX B

Steel Pipeline Protective Coating

Decision Tree

Major Selection Criteria for Steel Pipeline Coatings

The major success criteria for the selection of protective coating systems for new steel pipelines are as follows:

- A. Coating provides excellent adhesion to properly prepared steel substrate.
- B. Coating provides excellent cohesive strength. (Adheres well to itself or between coats or applications and has good internal film strength.)
- C. Coating has low permeability properties meaning it is resistant to water penetration and moisture transfer.
- D. Coating provides the necessary chemical resistant to the soil and ground water conditions.
- E. Coating has adequate thickness and strength to resist soil stresses once installed.
- F. Coating provides excellent resistance to cathodic disbondment if I.C.C.P. is also provided for the pipeline.
- G. Coating system provides ease of good application and performance at field joints and for repairs made at damaged areas associated with handling, installation, and backfilling.
- H. Coating system provides sufficient resistance to damage from backfilling operations. This can be achieved through flexibility or abrasion resistance associated with hardness.
- I. Cost is also a consideration.

Protective Coatings Decision Tree
Steel Pipe
(Open Cut Applications)

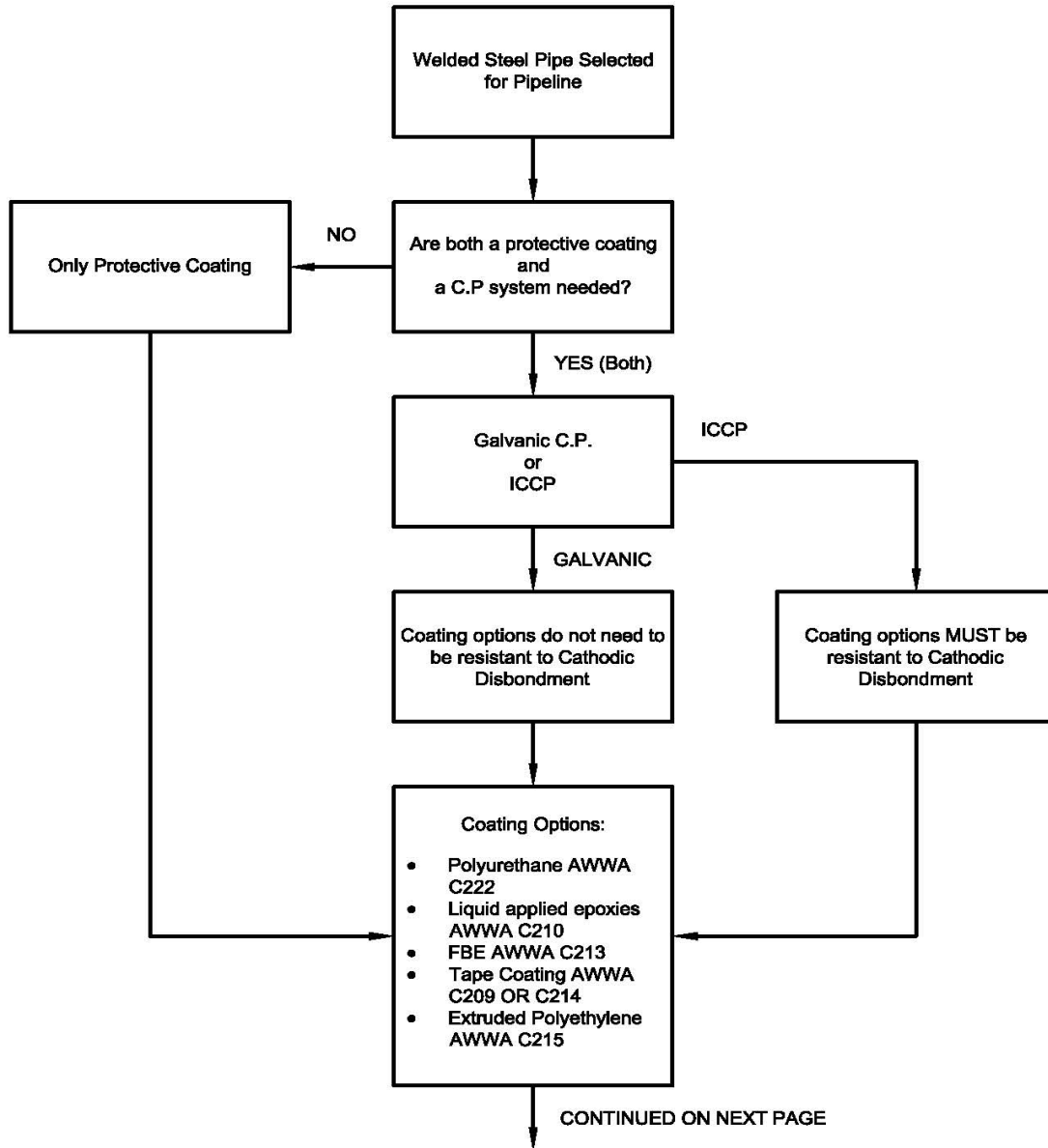

**Protective Coatings Decision Tree
Steel Pipe
(Open Cut Applications)**

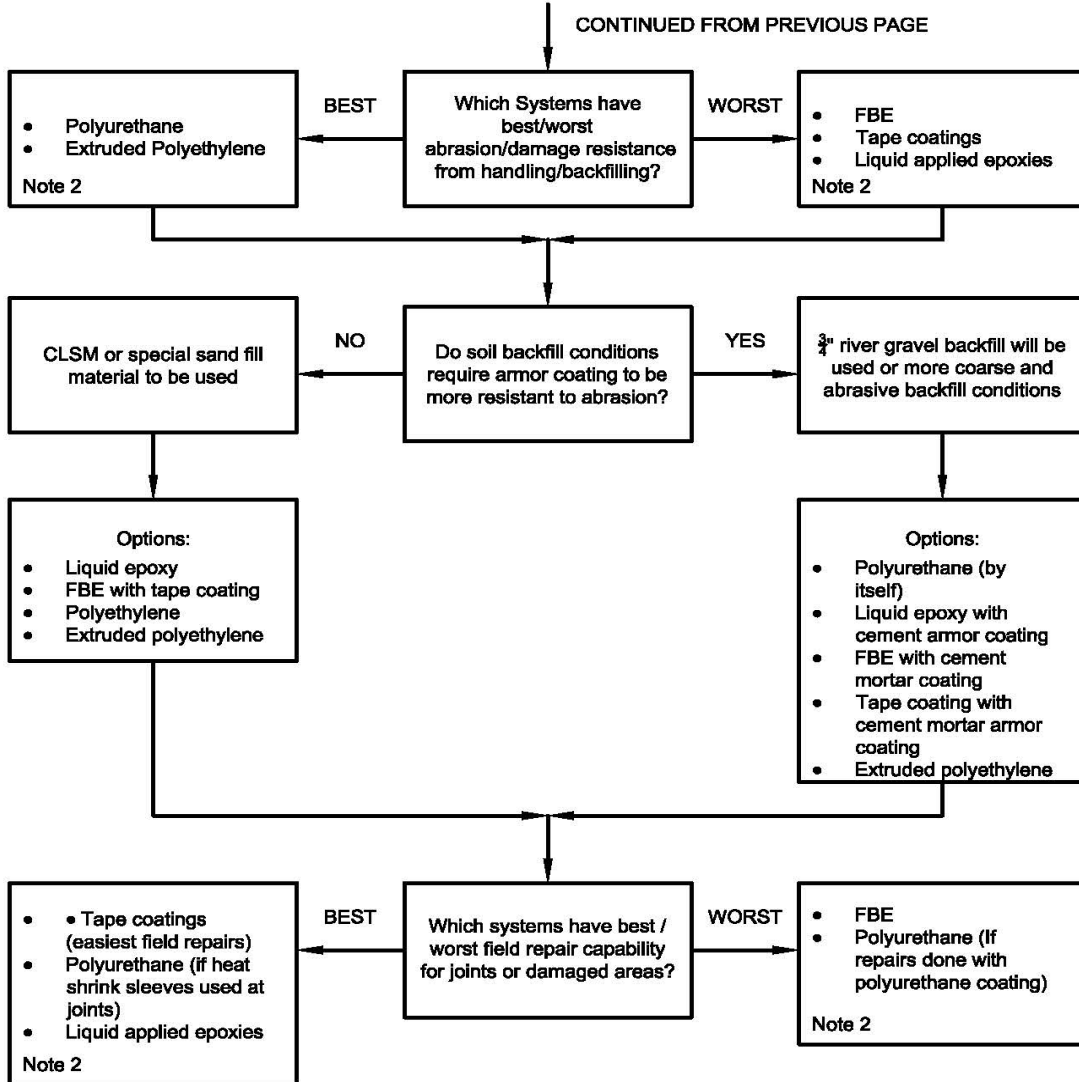

Notes:

1. For HDD applications, the use of Armor Coatings (epoxy based) over Polyurethane Coatings or FBE or Tape Coatings should be considered, and a test pull back should be performed to confirm good results. The epoxy polymer concrete armor coating will serve to protect the corrosion protection coating from damage during the pull back installation of the new pipeline. Also, for HDD applications, the coating system must provide sufficient flexibility or strength or both in order to not disbond from the pipe during pull back through bends in the hole.
2. Protective coating systems listed are in order of best or worst categories.
3. If ICCP is selected, be certain there is good test data provided demonstrating cathodic disbondment resistance for the coatings selected.
4. This decision tree assumes that all of the protective coating systems listed above provide appropriate adhesion, cohesive strength, permeability properties, chemical resistance, thickness and strength, and cathodic disbondment resistance.

APPENDIX E – Procedure for Water Tapping Services into Reinforced Concrete Pipe (RCP) and Concrete Cylinder Pipe (CCP)



City of Phoenix
WATER SERVICES
DEPARTMENT

PROCEDURE FOR WATER TAPPING SERVICES INTO REINFORCED CONCRETE PIPE (RCP) OR CONCRETE CYLINDER PIPE (CCP)

I. PURPOSE

This procedure is to clarify and streamline the requirements of water service taps made on Reinforced Concrete Pipe (RCP) or Concrete Cylinder Pipe (CCP).

II. APPLICABILITY

This procedure applies to all water service taps made on an RCP or CCP water main, including domestic water service taps, fire line taps and water main extension tapping connections.

III. WSD PERMIT TAPPING SERVICES PROCEDURE

When the Water Services Department (WSD) receives a request for a domestic water service connection on a RCP or a CCP water main, the following steps shall be followed:

1. WSD Development Planning Division (DP) will verify that the main is RCP/CCP either by as-built review, if the pipe type is shown, or through field verification by Water Distribution.
 - a. If the main is smaller than 16 inches, the main may be mislabeled in GIS.
 - b. If the main is 16 inches, verify with Water Modeling that the main is “acting” as a distribution main not a transmission main.
2. Once ADP confirms that the main is RCP/CCP, the developer or its contractor must select a tapping contractor approved by Water Services Department to tap into an RCP main. For CCP mains, a field evaluation will be needed to verify if an approved tapping contractor will need to be selected or if the tapping can be completed by City crews.
3. The developer or its contractor shall coordinate with WSD ADP staff on when the tap will be installed and if a shutdown will be necessary. A shut-down is only needed if tapping into mains that are larger than 12 inches. If a shutdown is necessary, a Water Main Shutdown request form shall be submitted to WSD through ADP staff. If a water transmission main is allowed to be tapped, a Maintenance of Plant Operation (MOPO) form may also be required to be submitted to the WSD Shutdown Committee.
4. Prior to the tap being made, ADP staff will witness a pressure test of the tapping sleeve and valve. A Water Distribution representative will be notified when the tap sleeve passes the pressure test.
5. After the tap is complete, the developer or its contractor shall coordinate with ADP staff to install the service line and set the water meter and vault, if required. ADP staff will

coordinate with Water Distribution and Water Meter divisions to facilitate the construction.

IV. PDD PERMIT TAPPING SERVICES PROCEDURE

When the Planning and Development Department (PDD) receives a request for a fire line connection or a water main extension connection on a RCP or a CCP water main, the following steps shall be followed:

6. PDD civil inspectors shall notify WSD ADP staff the fire line/water main tap request. ADP staff will verify that the main is RCP/CCP either by as-built review, if the pipe type is shown, or through field verification by Water Distribution.
 - a. If the main is smaller than 16 inches, the main may be mislabeled in GIS.
 - b. If the main is 16 inches, verify with Water Modeling that the main is “acting” as a distribution main not a transmission main.
7. Once ADP confirms that the main is RCP/CCP, ADP staff shall notify PDD civil inspectors of the findings. PDD civil inspectors will then notify the developer or its contractor that they must select a tapping contractor approved by WSD to tap into the RCP main. For CCP mains, a field evaluation will be needed to verify if an approved tapping contractor will need to be selected or if the tapping can be completed by City crews.
8. WSD ADP staff will coordinate with PDD civil inspectors on when the tap will be installed and if a shutdown will be necessary. A shut-down is only needed if tapping into mains that are larger than 12 inches. If a shutdown is necessary, a Water Main Shutdown request form shall be submitted to WSD through ADP staff. If a water transmission main is allowed to be tapped, a Maintenance of Plant Operation (MOPO) form may also be required to be submitted to WSD Shutdown Committee.
9. Prior to the tap being made, PDD civil inspectors will witness a pressure test of the tapping sleeve and valve. A Water Distribution representative will be notified when the tap sleeve will be installed.
10. PDD civil inspectors will inspect the installation of the tapping sleeve and the service line to the property line.

APPENDIX F - Construction Specification for Ductile Iron Sanitary Sewer Lines

SECTION 751

DUCTILE IRON SANITARY SEWER LINES

751.1 DESCRIPTION

Newly installed sanitary sewer lines constructed of ductile iron pipe (DIP) materials, typically used in residential, non-industrial sanitary sewer applications, operating under gravity flow conditions, shall include a cured-in-place-pipe (CIPP) protective lining conforming to applicable standard specifications and details, except as otherwise required on the plans or as modified in the special provisions.

751.2 SANITARY SEWER PIPE LINING

Ductile iron gravity sewer pipe shall be installed in accordance MAG Section 750 and American Society for Testing and Materials (ASTM) A746. All newly installed ductile iron pipe shall be lined using a Cured-in-Place Pipe (CIPP) conforming to the requirements of Section 751.4.

Cured-in-place-pipe (CIPP) liner shall be provided in accordance with ASTM D5813 – Standard Specification for Cured-in-Place Thermosetting Resin Sewer Piping Systems (Type III - Fully Deteriorated Host Pipe). Acceptable CIPP lining systems include isophthalic polyester resin, epoxy vinyl ester resin, reinforced fiberglass liner, or approved equal.

CIPP liner shall be installed per ASTM F1216 – Standard Practice for Rehabilitation of Existing Pipelines and Conduits by the Inversion and Curing of Resin-Impregnated Tube or ASTM F2019 – Standard Practice for Rehabilitation of Existing Pipelines and Conduits by the Pulled in Place Installation of Glass Reinforced Plastic Cured-in-Place (GRP-CIPP) Using the UV-Light Curing Method, or ASTM F1743 – Standard Practice for Rehabilitation of Existing Pipelines and Conduits by Pulled-in-Place Installation of Cured-in-Place Thermosetting Resin Pipe (CIPP).

751.2.1 SUBMITTALS

The following submittals shall be provided to the City or City's Representative a minimum of ten (10) working days prior to ordering CIPP lining materials for approval:

1. Shop drawings which detail short- and long-term properties (providing all supporting test data) of all component materials.
2. Representative cured liner sample (1-foot in length) for each diameter size of the same resin and felt/fiberglass liner proposed for the project depicting all material components and final quality of workmanship that can be expected on this project.
3. Structural calculations of CIPP liner thickness, displaying the Professional Seal of a Civil Engineer in the State of Arizona for each CIPP liner not depicted in Section 751.4.
4. 10,000-hour third party, 50-year Flexural Creep Modulus test data. Test shall be in accordance with ASTM D2990 at 10,000 hours. If approved 10,000-hour tests are not available, a minimum 50% reduction (50% retention) of Flexural Modulus of Elasticity (per ASTM F1216) shall be used for all design calculations.
5. Detailed description of method for quality control test sampling.

SECTION 751

6. Independent laboratory test reports of CIPP sample(s) and tests as specified in Section 1.06.
7. Remote visual inspection video and reports as specified in Section 751.6
8. Liner manufacturer's recommended installation procedures per ASTM F1216, ASTM F1743, or ASTM F2019. Recommendations for material storage and temperature control, CIPP liner handling, insertion, curing, trimming, and finishing.
9. Liner manufacturer's recommended maximum pulling force to be applied to the liner (if pulled-in-place method employed) or maximum inflation pressure (if inversion method employed).
10. Resin manufacturer's proposed rate of cure temperature change (heating and cooling) and the target temperature and duration for cure of resin along with the maximum rate and target temperature for cool down prior to the termination of the cure process.
11. Resin manufacturer's proposed exposure time to ultraviolet (UV) light and recommended travel speed of UV light train for wattage of light bulbs used.
12. Certification obtained within the previous six (6) months of the Contractor UV Light bulbs wattage output.
13. Certification showing the Contractor is currently licensed by the appropriate licensor to perform CIPP installation. Certification shall be given to the City or City Representative before any materials are delivered to the job site.
14. A certified affidavit, signed by an officer of the installation Company, shall be provided stating that the on-site superintendent has received proper training in the manufacturer's recommendations for CIPP liner installation methods and procedures.
15. Certification stating CIPP tube and resin have been manufactured in accordance with ASTM F1216, ASTM F2019, ASTM D578, and ASTM D5813 and is suitable for its intended use.
16. Test results for chemical resistance performed on a previously prepared sample of the finished product proposed for this project. Contractor shall submit a certified affidavit, signed by an officer of the Company, stating that the resin the tests apply to and the resin submitted for this project are the same.
17. Contractor shall submit method of measuring defects and an outline of specific repair or replacement procedures as recommended by the tube manufacturer for potential defects removal that may occur in the installed CIPP. Potential defects within the CIPP that cannot be repaired shall be clearly defined by the Contractor based on the manufacturer's recommendations, accompanied by a proposal for compensation to the City.
18. Manhole connection (liner termination) detail and material proposed to seal annular space between the liner and host pipe.
19. Lateral connection detail and material proposed to seal the interface between the lateral opening and CIPP liner.
20. Warranty information and certificates.
21. Safety Data Sheets (SDS) for all hazardous chemicals used or expected to be on-site. At a minimum, sheets for the resin, catalyst, cleaners, and repair agents should be submitted.

751.3 - CIPP LINER QUALITY ASSURANCE

1. Sample shall be cut from a section of cured CIPP at an intermediate manhole or at the termination point that has been inverted through a similar diameter pipe or other restraining system which will be held in place by a suitable heat sink, such as sandbags per ASTM F1216 or ASTM F2019.

Rev 2021

SECTION 751

2. CIPP liner samples taken shall be sent to an independent laboratory for quality control testing, accompanied by FORM A – CHAIN OF CUSTODY.
3. Samples taken for testing shall be individually labeled and logged to record the following:
 - a. Sanitary Sewer Owner's name.
 - b. Project title.
 - c. Unique sample number.
 - d. Pipe segment number (Upstream / Downstream manhole number).
 - e. Date and time sample was taken.
 - f. Name of Contractor.
 - g. Date, location, and name of person by whom the sample was taken.
4. SAMPLE TESTING: The cured sample shall be tested by an independent testing laboratory approved by the City or City's Representative. Project approval will not be made until acceptable test results are received by the City or City's Representative. The Contractor shall be responsible for any deviation from the specified physical properties and those evaluated through testing. Failure to meet the specified physical properties will result in the CIPP liner being considered defective work which will be handled in accordance with MAG Section 106. The Contractor shall be responsible for all costs associated with the testing of the liner physical properties and repair of any defective work.
5. SAMPLING FREQUENCY: The above-stated sampling shall be performed for each manufacturing lot of CIPP liner materials (per diameter size). A sample shall be taken every 3,000 linear feet or one (1) delivery load of liner whichever is less. City or City's Representative reserves the right to request one (1) additional test for every 3,000 linear feet or one (1) semi-trailer load of CIPP liner delivered whichever is less.
6. Grounds for rejection of installed CIPP liner include, but not limited to the following:
 - a. CIPP sample sent to a testing laboratory that is missing City or City Representative signature.
 - b. CIPP sample sent to a testing laboratory that is missing the return of the completed Chain of Custody form.
 - c. Chain of Custody form missing information or signatures of all those who handled or processed the sample, including the signature of the laboratory technician performing the testing.
 - d. Laboratory test results not meeting minimum specification requirements.
7. Rejected length of liner is defined as the entire liner segment from upstream manhole to downstream manhole.
8. Contractor shall pay all costs and fees associated with the sampling, shipping, and independent laboratory testing.

Rev 2021

SECTION 751

9. Each liner shall be labeled of the liner manufacturer with a permanent unique identification number that is referenced to accompanying documentation. Accompanying documentation shall include the following:
1. CIPP liner manufacturer's company name.
 2. Location the CIPP liner was manufactured.
 3. CIPP liner felt or fiberglass supplier.
 4. Resin manufacturer and supplier.
 5. Date of resin impregnation into CIPP liner.
 6. Unique identification number of CIPP liner.
 7. Resin identification number.
 8. Resin weight – lbs/ft.
 9. Resin and felt weight – lbs/ft.
 10. Manufactured CIPP liner lengths both “dry” and resin impregnated “wet”.
 11. CIPP liner thickness – mm.
 12. CIPP liner outside diameter – inches.
10. PERFORMANCE REQUIREMENTS: Diameter and wall thickness of liner shall be manufactured to size such that when installed, it shall provide at least the minimum wall thickness as determined according Section 751.4.

Proposed liner material shall be inert to attack by domestic sewage and suitable for use in underground sanitary sewer environments. The chemical resistance tests should be completed in accordance with Test Method ASTM D543. Exposure should be for a minimum of one (1) month at 73.4 degrees Fahrenheit. During this period, the CIPP test specimens should lose no more than 20 percent of their initial flexural strength and flexural modulus when tested in accordance with ASTM F1216 Appendix X2 when subjected to the following solutions:

Chemical Solution	Concentration (%)
Tap Water (pH 6-9)	100
Nitric Acid	5
Phosphoric Acid	10
Sulfuric Acid	10
Gasoline	100
Vegetable Oil	100
Detergent	0.1
Soap	0.1

Liner material shall be manufactured in such manner as to result in tight-fitting liner after installation. There shall be no measurable continuous annular space between outside diameter of the liner and existing host pipe. Measurable annular space will result in the CIPP liner being considered defective work which will be handled in accordance with MAG Section 106.

Rev 2021

SECTION 751

CIPP liner shall meet minimum liner tube length requirements. Excessive shrinkage or short CIPP liner is considered to be defective work and will be handled in accordance with MAG Section 106.

If any damage occurs to the host or lined pipe caused by construction activities, the Contractor shall perform repairs as recommended by the City or liner manufacturer as applicable at no additional cost to the City. Damage to the pipe will include but not be limited to gouging, marring, and scratching that forms a clear depression in the pipe.

751.4 - CIPP LINING

Newly installed ductile iron pipe shall be CIPP lined to provide corrosion protection. Installed liner thickness shall be provided per to the following tables according to the materials proposed. Depth of pipe shall take into consideration intermediate elevated areas (i.e. elevated road surfaces, hills) requiring adjustment of the reported depth of manhole closest to the raised elevation and adding the total elevated height to establish the new design minimum pipe depth at invert criteria.

751.4.1 – FELT LINING MATERIAL

The minimum nominal CIPP thickness to be supplied for felt liner installed in pipes with inside diameter 15-inches and less per ASTM F1216 are as follows:

H-20 Loading		
Pipe Diameter	Pipe Depth at Invert (ft)	Nominal CIPP thickness to be supplied (mm)
8	4 to 13.5	4.5
8	13.5 to 20	6
10	4 to 8	4.5
10	8 to 15.5	6
10	15.5 to 20	7.5
12	4 to 10	6
12	10 to 17	7.5
12	17 to 20	9
15	4 to 5.5	6
15	5.5 to 10	7.5
15	10 to 15.5	9
15	15.5 to 20	10.5

Rev 2021

SECTION 751

E-80 (Railroad) Loading		
Pipe Diameter	Pipe Depth at Invert (ft)	Nominal CIPP thickness to be supplied (mm)
8	4 to 20	6
10	4 to 20	7.5
12	4 to 20	9
15	4	12
15	4 to 19	10.5
15	19 to 20	12

751.4.2 – FIBERGLASS LINING MATERIAL

The minimum nominal CIPP thickness to be supplied for fiberglass liner installed in pipes with inside diameter 15-inches and less per ASTM F2019 are as follows:

H-20 Loading		
Pipe Diameter	Pipe Depth at Invert (ft)	Nominal CIPP thickness to be supplied (mm)
8	4 to 10.5	3
8	10.5 to 20	4.5
10	4 to 5.5	3
10	5.5 to 16	4.5
10	16 to 20	6
12	4 to 10.5	4.5
12	10.5 to 20	6
15	4 to 5.5	4.5
15	5.5 to 12	6
15	12 to 20	7.5
E-80 (Railroad) Loading		
Pipe Diameter	Pipe Depth at Invert (ft)	Nominal CIPP thickness to be supplied (mm)
8	4 to 20	4.5
10	4 to 20	6
12	4 to 20	7.5
15	4 to 5.5	9
15	5.5 to 15.5	7.5
15	15.5 to 20	9

Rev 2021

SECTION 751

751.4.3 – LINING OF PIPES WITH DIAMETER LARGER THAN 15-INCHES

The minimum nominal CIPP thickness to be supplied for liners installed in pipes with inside diameter greater than 15-inches shall be designed according to the materials proposed and in accordance with the procedures of ASTM F1216 Appendix X1 or ASTM D3567 or ASTM F2019 Appendix X1 and the following parameters.

All material properties used in design calculations shall be long-term (time-corrected) values. Contractor shall familiarize itself with site conditions when preparing liner thickness design.

The following minimum parameters shall be assumed for the liner thickness design calculations.

1. Modulus of soil reaction, $E'_s = 1,000$ psi (**Type III fully deteriorated host pipe**)
2. Unit weight of soil = 140 pcf
3. The minimum ovality shall be 2.0 %
4. Groundwater to ground surface elevation
5. AASHTO H20 Traffic loads or E80 (Railway Load)
6. Safety Factor = 2.0
7. Pipe depth at invert = Actual Depth

Design thickness calculations shall be professionally sealed by an Arizona Registered Professional Civil Engineer.

751.5 - FINISHED AND CURED CIPP LINER PROPERTIES

The physical properties of the cured CIPP shall have minimum initial test values as given below for resin. Properties for these or any other enhanced resins shall be substantiated with test data.

Standard Resin			
Test Property	Test Value Felt Liner	Test Value Fiberglass Liner	Test Method
Flexural strength	4,500 psi	6,500 psi	ASTM D790
Flexural modulus	300,000 psi	725,000 psi	ASTM D790
50-year flexural creep modulus	150,000 psi	362,500 psi	ASTM D2990

The Contractor shall provide CIPP liner terminations. If the CIPP liner fails to make a tight seal at the manhole walls, a seal consisting of a resin mixture compatible with the liner/resin system shall be applied in accordance with manufacturer specifications and approved by the City or City's Representative.

Rev 2021

SECTION 751

751.6 – SERVICE LATERAL CONNECTION AND SEALING SYSTEM

- a. After the CIPP liner curing in the main is complete, lateral connections shall be re-established internally using robotic cutters guided via closed circuit television (CCTV) or computer aided mapping. The cut CIPP liner shall have no jagged edges or obstructions that prevent proper installation of lateral connection seal and creates a smooth transition from lateral to main.
- b. The Contractor shall connect all service laterals installed in DIP pipe or as directed by the CITY. Edges of the lateral connection penetrations to the sewer main shall be sealed to minimize infiltration, ex-filtration, and root intrusion.
- c. Lateral connection shall be sealed using a resin impregnated laminate manufactured by “Cosmic Top Hat™” system or approved equal. Liner shall extend four to six inches beyond the first lateral joint.
- d. The Contractor shall be responsible for ensuring lateral connection material proposed is compatible with materials installed to rehabilitate the sewer main and conducive to installation into the existing lateral material, connection geometry, and diameter.

751.7 - REMOTE CCTV INSPECTION OF LINED SEWERS

The sewer interior shall be inspected using a camera capable of producing a color image for permanent record of inspection in digital format (mpeg or jpeg format). CCTV documentation shall be performed according to National Association of Sanitary Service Company (NASSCO) standards. The pipe shall be dewatered during CCTV inspection recording.

CCTV equipment shall be digital, Panaramo 360 or approved equal for post liner installation inspection. The CCTV cameras shall be capable of providing a 360-degree view of the pipe interior. A footage counter device, which measures the distance traveled by the camera in the sewer, shall be accurate to plus or minus 2 feet in 1,000 feet. Video recording of all sewer line inspections shall be transferred on digital thumb drives or portable hard drives formatted to be compatible with Microsoft products.

Project name, date, pipe diameter, and footage shall be permanently recorded on the inspection video. The camera image shall be down the center axis of the pipe when the camera is in motion. Points of interest shall also be documented and shall include, but not be limited to, defects, improper liner installation, or defects in the liner (including, but not limited to, bumps, folds, tears, dimples, etc.). Final documentation shall be submitted after all repairs (if necessary) are completed as a record and approval of work performed.

Rev 2021

SECTION 751

FORM A CHAIN OF CUSTODY

PROJECT:	CITY:
CITY CONTRACT NUMBER:	
PROJECT NUMBER:	

OWNERS REPRESENTATIVE:	
COMPANY NAME:	
ADDRESS	
CONTACT PHONE NUMBER:	
CONTACT NAME:	

CONTRACTOR:	
COMPANY NAME:	
ADDRESS	
CONTACT PHONE NUMBER:	
CONTACT NAME:	

TESTING LABORATORY:	
LABORATORY NAME:	
ADDRESS	
CONTACT PHONE NUMBER:	
FAX NUMBER	
CONTACT NAME:	

Date Sample Taken:		Pipe Segment No.	
Sample Number:		Pipe Diameter	
Quarter Section No.		Liner Design Thickness:	
Upstream Manhole No.		Resign Type:	
		Downstream Manhole No.	

SAMPLE TAKEN BY:	SIGNATURE:	
		DATE
	PRINT NAME:	

ENGINEER, RECEIVED BY:	SIGNATURE:	
		DATE
	PRINT NAME:	

LABORATORY RECEIVED BY:	SIGNATURE:	
		DATE
	PRINT NAME:	

TEST RESULTS, RECEIVED BY:	SIGNATURE:	
		DATE
	PRINT NAME:	

**** End of Section ****

Rev 2021

APPENDIX G – MOPO Examples

	Name of Project		
	Date MOPO submitted:		
	Start Date		
	Approx Duration		

		MOPO written by:		
Site Location		Cell Phone:		
Project		Project Manager		
		Cell Phone:		
Detailed Work Description				

Pre-work Items		
Item	Activity / Job Preparations	Departments / Section / Contractor
a	POTHOLE REQUIRED PRIOR TO MOPO SUBMITTAL	
b		
c		
d		
e		
f		
g		
h		
i		

Project Organization Details		
Organization	Lead Person	Responsibilities

Work Activities				
Item	Activity	Start Time	Tentative work Dates	Departments / Section / Contractor
1	List out activities working around transmission mains. SOFT DIG METHOD REQUIRED WITHIN 10' OF TRANSMISSION MAIN		Start Date	
2				
3				
7				
8				

Item	Activity	Start Time	Tentative work Dates	Departments / Section / Contractor
9				
10				
11				
12				
13	Large Valves: INFO FILLED OUT BY WSD			

14

Additional items that will need to be addressed			
Activity	Start Time	Date	Departments / Section / Contractor
Safety			
Safety protocols met before work to commence			All Parties
EMERGENCY / 24-HR CONTACT LIST			
WSD Emergency Phone Number		602-261-8000	