



City of Phoenix
 PLANNING AND DEVELOPMENT DEPARTMENT

Staff Report Z-51-20-2
March 5, 2021

Deer Valley Village Planning Committee Meeting Date: March 11, 2021

Planning Commission Hearing Date: April 1, 2021

Request From: S-1 (Ranch or Farm Residence) (20.08 acres)

Request To: R-3A (Multifamily Residential) (20.08 acres)

Proposed Use: Single-family residential

Location: Approximately 4,000 feet north of the northeast corner of Black Canyon Highway and Jomax Road

Owner: Fred Bishop, et al

Applicant: Chuck Chisholm, K Hovnanian Homes

Representative: Nick Wood, Esq. Snell & Wilmer, LLP

Staff Recommendation: Approval, subject to stipulations

<u>General Plan Conformity</u>			
<u>General Plan Land Use Map Designation</u>		Mixed Use (Commerce/Business Park or 15+ dwelling units per acre)	
<u>Street Map Classification</u>	Black Canyon Highway	Existing Freeway	Approximately 210 feet east half, including frontage roads
<p><i>CELEBRATE OUR DIVERSE COMMUNITIES AND NEIGHBORHOODS CORE VALUE; CERTAINTY AND CHARACTER; LAND USE PRINCIPLE: New development and expansion or redevelopment of existing development in or near residential areas should be compatible with existing uses and consistent with adopted plans.</i></p> <p>As stipulated, the proposed development is compatible with existing nearby uses by employing compatibility measures such as increased setbacks and enhanced landscape</p>			

standards.

CELEBRATE OUR DIVERSE COMMUNITIES AND NEIGHBORHOODS CORE VALUE; CERTAINTY AND CHARACTER; DESIGN PRINCIPLE: Protect and enhance the character of each neighborhood and its various housing lifestyles through new development that is compatible in scale, design, and appearance.

The proposal promotes the expansion of residential land uses in the area. As stipulated, the proposed development is consistent with the scale, design, and zoning which has been approved in the surrounding area.

CONNECT PEOPLE & PLACES; OPPORTUNITY SITES; LAND USE PRINCIPLE; Promote and encourage compatible development and redevelopment with a mix of housing types in neighborhoods close to employment centers, commercial areas, and where transit or transportation alternatives exist.

The subject site is located within the boundaries of the Phoenix Designated Employment Center of North Black Canyon and located in close proximity to the Black Canyon Highway where higher density and intensity uses are encouraged.

Applicable Plans, Overlays, and Initiatives

[North Black Canyon Major Employment Center](#) – See Background Item No. 6

[Phoenix Housing Plan](#) – See Background Item No. 7

[Tree and Shade Master Plan](#) – See Background Item No. 8

[Zero Waste PHX](#) – See Background Item No. 9

Surrounding Land Uses/Zoning

	<u>Land Use</u>	<u>Zoning</u>
On Site	Single-Family residences	S-1 (Ranch or Farm Residence)
North	Multifamily Residential and vacant single-family (pending multifamily)	R-3A PCD (Multifamily Residence District, Planned Community District) and R-3A
South	Vacant	R-3 (Multifamily Residential)
East	Drainage/Wash Area	S-1 (Ranch or Farm Residence)
West	Black Canyon Freeway and Single-Family Residences (across the Black Canyon Freeway) and vacant single-	R1-6 (Single-Family Residence District) and R-3A (Multifamily Residential)

	family (pending multifamily)	
--	------------------------------	--

R-3A Multifamily Residence District (Planned Residential Development Option)		
<u>Standards</u>	<u>Requirements</u>	<u>Provisions on the Proposed Site Plan</u>
Gross Acreage	No minimum	20.08 acres
Maximum Number of Units	464 maximum, 5530 with bonus	285 units, maximum
Maximum Dwelling Unit Density (units/gross acre)	23.1; 26.4 dwelling units per acre with bonus	Met – 14.19 dwelling units per acre
Minimum Perimeter Building Setbacks	20 feet adjacent to a public street 15 feet adjacent to property lines	West: 25 feet on frontage road - Met North: 15 feet along private drive - Met East: 15 feet - Met South: 20 feet - Met (as stipulated)
Minimum Landscape Setbacks	20 feet adjacent to a public street 5 feet adjacent to property lines	West: 25 feet - Met North: 25 feet - Met East: 15 feet - Met South: 20 feet - Met (as stipulated)
Maximum Lot Coverage	45%	Met - 31%
Maximum Building Height	3 stories or 40 feet for first 150 feet; 1 foot in 1 foot increase to 48 feet height, 4-story maximum	Met - 2 stories and 30 feet
Minimum Common Areas	Minimum 5% of gross area	Met - 28%, minimum

Background / Issues / Analysis

1. SUBJECT SITE

This request is to rezone a 20.08-acre site, located approximately 4,000 feet north of the northeast corner of Black Canyon Highway and Jomax Road from S-1 (Farm or Ranch Residence) to R-3A (Multifamily Residence District) to allow a single-family residential townhomes.

The subject site was annexed into the City of Phoenix from Maricopa County in 1989. The site is comprised of eight lots. Three are large lots with single-family homes on each. There is also a small lot with a small home or trailer. The remainder of the lots are vacant.

Access to the site is limited with the only access from the Black Canyon Freeway frontage road. The frontage road is located west of the site and is north bound only. To access the site, vehicles must exit from Black Canyon Freeway at Jomax Road and travel north along the frontage road approximately 4/5th (0.8) of a mile.

2. ZONING AND LAND USE

Subject Site:

The subject site is zoned S-1 (Ranch or Farm Residence) and contains three single-family residences on 20.08 acres.

North and Northwest:

The parcel abutting the subject site on the easternmost portion is included in the Dynamite Mountain Planned Community District (PCD) which rezoned the site from S-1 (Ranch or Farm Residence) to R-3A (Multifamily Residence District, Planned Community District) PCD with a specified density up to 22 dwelling units per acre through Rezoning Case No. Z-109-97. The property developed as multifamily in 2010 to a height of three stories. The parcel abutting to the north and west of the subject site was recently rezoned from S-1 (Ranch or Farm Residence) to R-3A (Multifamily Residence District) through Rezoning Case No. Z-42-20-2.

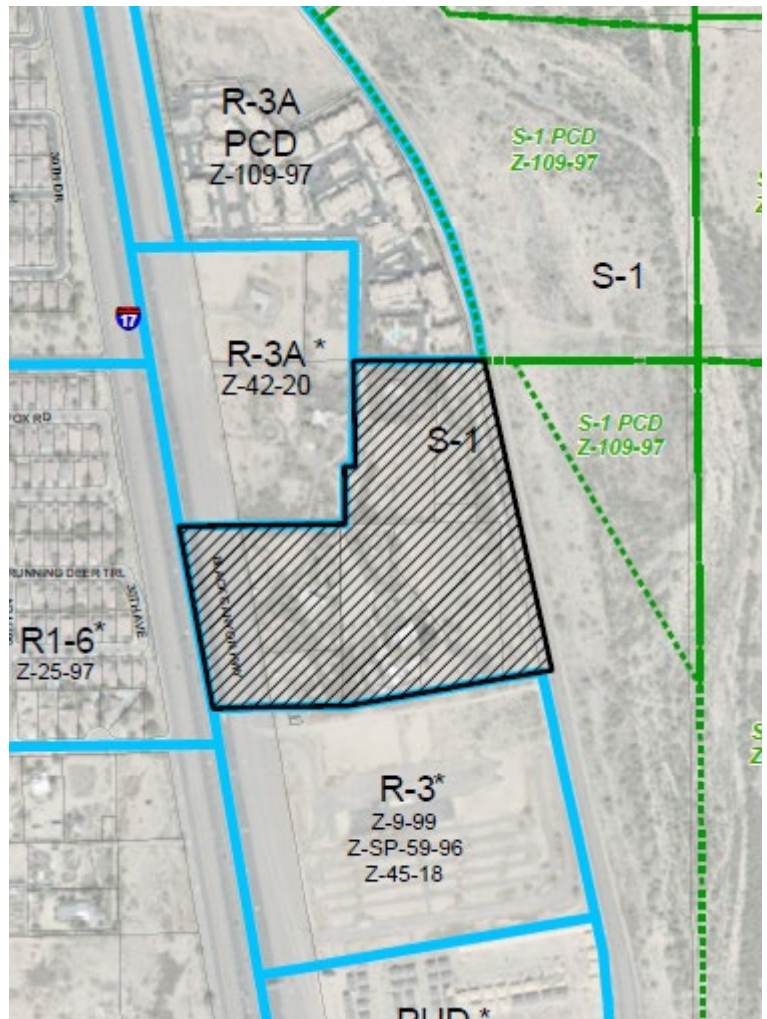

Surrounding Zoning, Source: Planning and Development Department

South:

The parcel to the south of the subject site is zoned R-3 (Multifamily Residence District)

through Rezoning Case No. Z-46-18 and is currently vacant.

West:

Immediately west of the subject site is the Black Canyon Freeway and its frontage roads. Beyond the Black Canyon Freeway (approximately 375 feet), is a single-family residential neighborhood zoned R1-6, approved through Rezoning Case No. Z-25-97.

3. GENERAL PLAN

Subject Site:

The General Plan Land Use Map designation for the subject site is Mixed Use (Commerce/Business Park or 15+ dwelling units per acre). The proposed use and zoning classification are consistent with the General Plan Land Use Map designation.

North and Northeast East:

The General Plan Land Use Map designation for the properties to the north and northeast are Mixed Use (Commerce/Business Park or 15+ dwelling units per acre) and Residential 5 to 15 dwelling units per acre.

East:

Floodplain

South:

The General Plan Land Use Map designation for the property to the south is Residential 5 to 15 dwelling units per acre.

West (Across Black Canyon Freeway).

The General Plan Land Use Map designation for the areas immediately west of the site across the Black Canyon Freeway is Residential 2 to 5 dwelling units per acre.

4. SITE PLAN

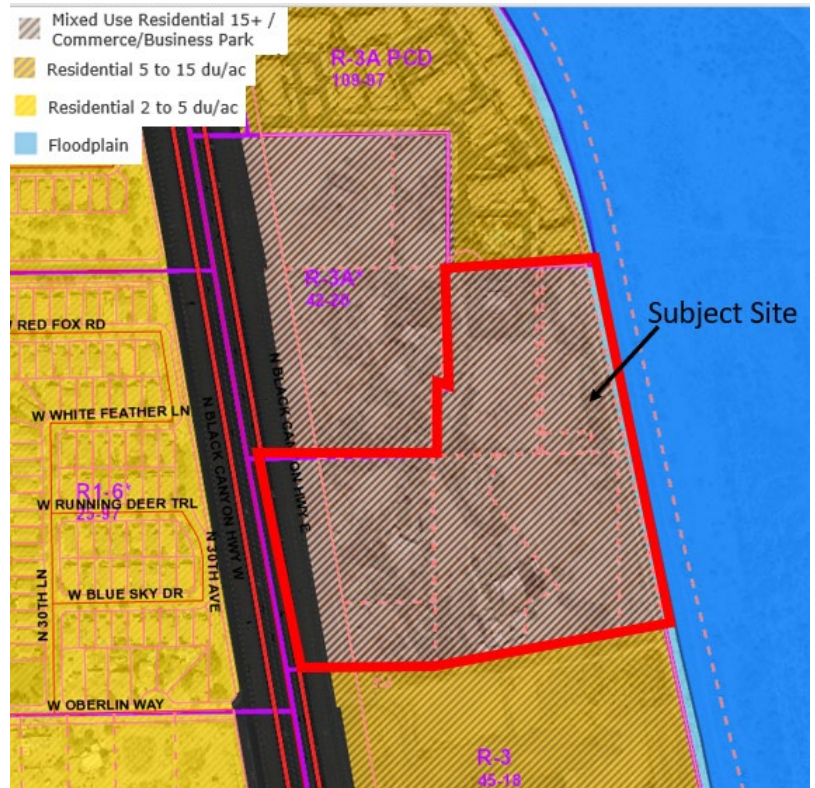

General Plan Land Use Map, Source: City of Phoenix Development and Development Department

The conceptual site plan depicts a single-family residential townhome development. The site plan indicates a single main point of entry from the frontage road just north of the Oberlin Way alignment on the west side Interstate 17 and a secondary ingress/egress point along Oberlin Way just south of the Dynamite Boulevard alignment, which is a private drive, along the north end of the site. The main point of entry along the frontage road will include enhanced landscaping as recommended in Stipulation No. 5.

Due to its location immediately adjacent to the Black Canyon Freeway, staff is recommending a series of stipulations to enhance the perimeter treatment of the site to mitigate any potential impact from the freeway.

To achieve consistency with other developments in the surrounding area staff is requesting several enhancements. Enhanced separation between the subject site and the Black Canyon Freeway frontage road will help to mitigate traffic noise. An enhanced landscape setback is also proposed along the southern site boundary.

These are addressed in Stipulation Nos. 6 and 7.



Conceptual Site Plan, Source: K Hovnanian Homes

The proposal for 285 units limits the number of dwellings allowed under the R-3A zoning district, which is consistent with other developments in the area. To ensure the site develops with no more than 285 units staff is recommending Stipulation No. 2.

The conceptual site plan includes two open space areas containing a minimum of two amenities in each area. Amenities in the open space areas will help to create a sense of community. Staff is recommending Stipulation No. 8 to ensure the site develops as

proposed.

For visual continuity with the multifamily project to the north, staff has stipulated to design standards for the perimeter wall. This is addressed in Stipulation No. 9.

5. ELEVATIONS

The proposal includes conceptual elevations that illustrate variations in roofline, window shapes and sizes, architectural embellishments and textural changes.

The building height is capped at two stories and below 30 feet. To ensure the elevations include architectural details and the proposed building height, staff is recommending Stipulation Nos. 1 and 3.



Conceptual Elevations, Source: K Hovnanian

6. **NORTH BLACK CANYON MAJOR EMPLOYMENT CENTER**

The subject site is located within the North Black Canyon Freeway and near the Deer Valley Major Employment Centers. The proposal adds housing options within the employment centers.

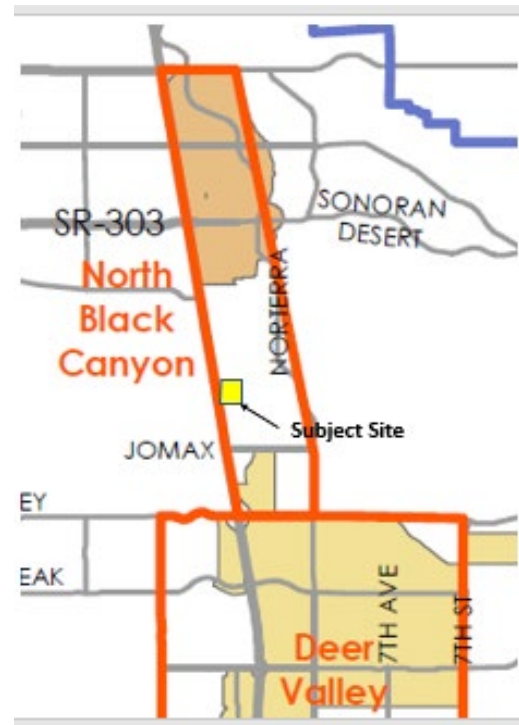

Figure 5: Source: City of Phoenix Planning and Development Department

7. **Housing Phoenix PLAN**

In June 2020, the Phoenix City Council approved the Housing Phoenix Plan. This Plan contains policy initiatives for the development and preservation of housing with vision of creating a stronger and more vibrant Phoenix through increased housing options for residents at all income levels and family sizes. Phoenix's rapid population growth and housing underproduction has led to a need for over 163,000 new housing units. Current shortages of housing supply relative to demand are a primary reason why housing costs are increasing.

The proposed development supports the Plan's goal of preserving or creating 50,000 housing units by 2030 by contributing to a variety housing types that will address the supply shortage at a more rapid pace while using vacant land in a more sustainable fashion.

8. **Tree and Shade Master Plan**

The Tree and Shade Master Plan encourages treating the urban forest as infrastructure to ensure the trees are an integral part of the City's planning and development process. Sidewalks on the street frontages should be detached from the curbs to allow trees to be planted on both sides of the sidewalk to provide thermal comfort for pedestrians and

to reduce the urban heat island effect. Staff is recommending several stipulations designed to provide trees and enhance shade within and adjacent to the development. Staff is recommending stipulations for a shaded sidewalk along the Black Canyon Freeway frontage road, per ADOT standards, in addition to enhanced tree and landscape areas and planting standards along the south and west property lines. These are addressed in Stipulation Nos. 4,5, 6 and 7.

9. [Zero Waste PHX](#)

The City of Phoenix is committed to its waste diversion efforts and has set a goal to become a zero-waste city, as part of the city's overall 2050 Environmental Sustainability Goals. One of the ways Phoenix can achieve this is to improve and expand its recycling and other waste diversion programs. Section 716 of the Phoenix Zoning Ordinance establishes standards to encourage the provision of recycling containers for multifamily, commercial and mixed-use developments meeting certain criteria. The proposed conceptual site plan does not show recycling facilities, but the applicant's materials mention that recycling bins will be provided for this development.

COMMUNITY INPUT SUMMARY

10. At the time the staff report was written no community correspondence had been received.

INTERDEPARTMENTAL COMMENTS

11. The Arizona Department of Transportation (ADOT) commented that the developer shall install detached sidewalks along the Black Canyon Freeway frontage road as well as an at grade concrete cap or berm to contain the asphalt roadway. This is addressed in Stipulation No. 4.
12. The Street Transportation Department commented that the developer submit a cross access agreement prior to preliminary site plan approval for Oberlin Way, all frontage road improvements shall go through ADOT and the developer shall construct all roadway infrastructure to code standards. These are addressed in Stipulation Nos. 10, 11 and 12.
13. The Aviation Department commented the site is located within the Phoenix Deer Valley Airport (DVT) traffic pattern airspace. The Aviation Department is requesting a Notice to future owners or tenants of proximity to disclose the existence and operational characteristics of the Phoenix Deer Valley Airport (DVT) to future owners or tenants of the property. The developer must file FAA Form 7460 as well and record an avigation easement over the site. These are addressed in Stipulation Nos. 13, 14 and 15.

14. The site is located in a larger area identified as being archaeologically sensitive. If further review by the City of Phoenix Archaeology Office determines the site and immediate area to be archaeologically sensitive, and if no previous archaeological projects have been conducted within this project area, it is recommended that archaeological Phase I data testing of this area be conducted. Phase II archaeological data recovery excavations may be necessary based upon the results of the testing. A qualified archaeologist must make this determination in consultation with the City of Phoenix Archaeologist. In the event archaeological materials are encountered during construction, all ground disturbing activities must cease within a 33-foot radius of the discovery and the City of Phoenix Archaeology Office must be notified immediately and allowed time to properly assess the materials. These are addressed in Stipulation Nos. 16, 17 and 18.
15. The Floodplain Management Division of the Public Works Department commented It has been determined that this parcel is not in a Special Flood Hazard Area (SFHA), but located in an Unshaded Zone X, on panel 1280 L of the Flood Insurance Rate Maps (FIRM) dated January 29, 2018.

The developer shall provide a hydraulic/hydrologic analysis of offsite storm water flows, when present, at the time of preliminary site plan submittal for verification of required infrastructure in regard to lot space and density.
16. The City of Phoenix Fire Department does not anticipate any problems with this case. However, they noted that there appears to be decorative pavers on the emergency service access road on the west side. All emergency service access roads will need to meet the specifications in Section 503.2 (2018 PFC). They also noted that the site and/or buildings shall comply with the Phoenix Fire Code and requested additional detail be provided on future site plan submittals.
17. The Water Services Department indicated that the site is surrounded with existing water and sewer mains that can potentially serve the development.
18. Development and use of the site is subject to all applicable codes and ordinances. Zoning approval does not negate other ordinance requirements. Other formal actions such as, but not limited to, zoning adjustments and abandonments, may be required.

Findings

1. The request is consistent with the General Plan Land Use Map designation of Mixed Use (Commerce/Business Park or 15+ dwelling units per acre).
2. As stipulated, the proposed development is compatible with the existing zoning and uses in the surrounding area.
3. The proposal will help achieve the goals of the Housing Phoenix Plan.

Stipulations

1. The maximum building height shall be 30 feet.
2. The development shall be limited to a maximum of 285 units.
3. All elevations of the buildings shall contain architectural embellishments and detailing such as textural changes, pilasters, offsets, recesses, variation in window size and location, and/or overhang canopies, as approved by the Planning and Development Department.
4. A sidewalk and landscaping strip shall be provided along the Black Canyon Freeway Frontage Road and shall be detached with a minimum five-foot-wide landscape area located between the sidewalk and back of curb and planted to the following standards, as approved by the Planning and Development Department.
 - a. Minimum 3-inch caliper large canopy, single-trunk, shade trees placed a minimum of 25 feet on center or equivalent groupings to provide a minimum of 75 percent shade on adjacent sidewalks.
 - b. Drought tolerant shrubs and vegetative groundcovers.
5. An enhanced landscaped entry shall be provided at the main entryway into the development off of the frontage road with a minimum 300 square feet of landscaped area on each side of the entrance. The landscaped areas shall be planted and maintained with a variety of at least three different plant materials, as approved by the Planning and Development Department.
6. A minimum landscape setback of 20 feet shall be required along the west property line and along the frontage road. These landscape setbacks shall include minimum 3-inch caliper large canopy shade trees planted a minimum of 20 feet on center or in equivalent groupings, as approved by the Planning and Development Department.

7. A minimum landscape setback of 20 feet shall be required along the south property line and shall include minimum 2-inch caliper trees planted a minimum of 20 feet on center or in equivalent groupings, as approved by the Planning and Development Department.
8. There shall be a minimum of two private open space amenity areas. Each area shall provide, at a minimum, two of the following active amenity elements or other similar elements, as approved by the Planning and Development Department:
 - a. Swimming Pool
 - b. Fire Pit
 - c. Pavilion or Ramada
 - d. Barbecue and Picnic Area
9. Perimeter walls adjacent to the frontage road and private drive to the north shall incorporate stone veneer, stonework, integral color CMU block or faux stone, and be compatible with the existing wall on the property line to the north, as approved by the Planning and Development Department.
10. The developer shall submit a cross-access agreement prior to preliminary site plan approval for APN 204-23-001A to support future cross-access of Oberlin Way.
11. All frontage improvements, access control and location of driveways shall be permitted and approved through ADOT.
12. The developer shall construct all streets within and adjacent to the development with paving, curb, gutter, sidewalk, curb ramps, streetlights, median islands, landscaping and other incidentals as per plans approved by the Planning and Development Department. All improvements shall comply with all ADA accessibility standards.
13. The property owner shall record documents that disclose the existence, and operational characteristics of Phoenix Deer Valley Airport (DVT) to future owners or tenants of the property. The form and content of such documents shall be according to the templates and instructions provided which have been reviewed and approved by the City Attorney.
14. The developer must file FAA Form 7460 and provide City FAA's no hazard

determination prior to construction permit approval, as per plans approved by the Planning and Development Department.

15. The developer shall grant and record an avigation easement to the City of Phoenix Aviation Department for the site, per the content and form prescribed by the City Attorney prior to final site plan approval.
16. If determined necessary by the Phoenix Archaeology Office, the applicant shall conduct Phase I data testing and submit an archaeological survey report of the development area for review and approval by the City Archaeologist prior to clearing and grubbing, landscape salvage, and/or grading approval.
17. If Phase I data testing is required, and if, upon review of the results from the Phase I data testing, the City Archaeologist, in consultation with a qualified archaeologist, determines such data recovery excavations are necessary, the applicant shall conduct Phase II archaeological data recovery excavations.
18. In the event archaeological materials are encountered during construction, the developer shall immediately cease all ground-disturbing activities within a 33-foot radius of the discovery, notify the City Archaeologist, and allow time for the Archaeology Office to properly assess the materials.

Writer

David Simmons

March 5, 2021

Team Leader

Samantha Keating

Exhibits

Zoning sketch map

Aerial sketch map

Site plan date stamped February 11, 2021

Elevations date stamped September 24, 2020 (7 pages)

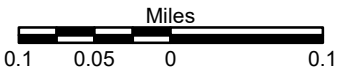
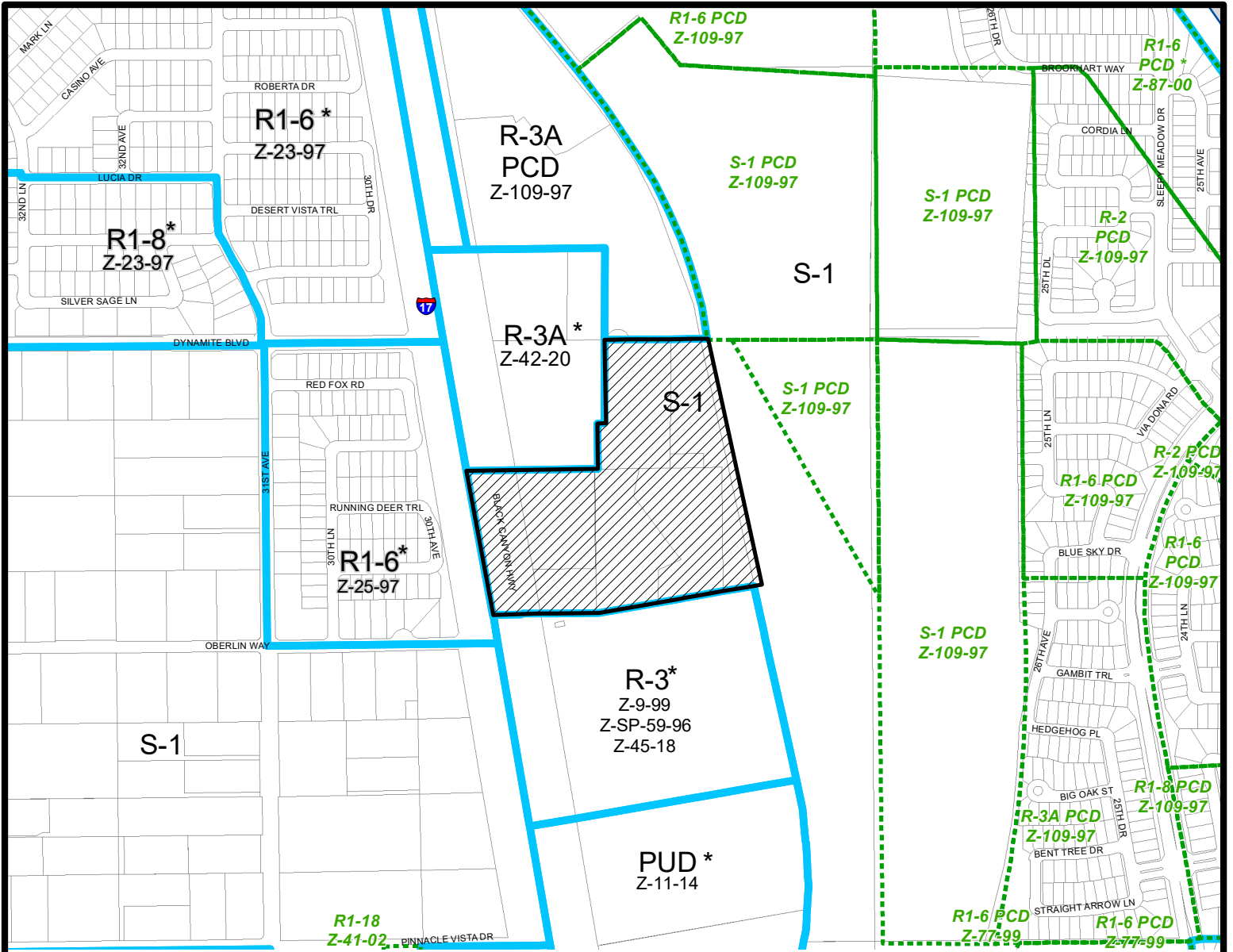

DEER VALLEY VILLAGE
CITY COUNCIL DISTRICT: 2

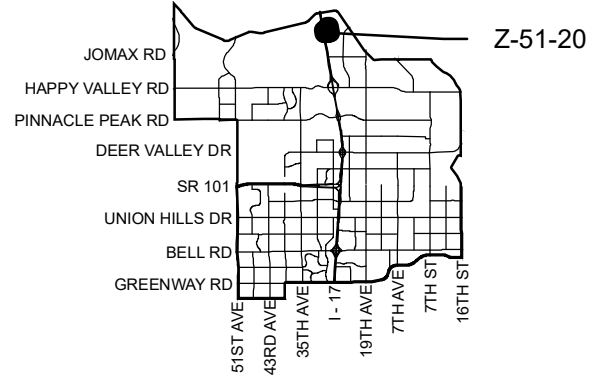

APPLICANT'S NAME: Chuck Chisholm, K Hovnanian Homes		REQUESTED CHANGE:	
APPLICATION NO. Z-51-20		FROM: S-1 (20.08 a.c.)	
DATE: 11/19/2020 REVISION DATES:		TO: R-3A (20.08 a.c.)	
GROSS AREA INCLUDING 1/2 STREET AND ALLEY DEDICATION IS APPROX. 20.08 Acres		AERIAL PHOTO & QUARTER SEC. NO. QS 50-22	
		ZONING MAP P-7	
MULTIPLES PERMITTED		CONVENTIONAL OPTION	
S-1		20	
R-3A		442	
		* UNITS P.R.D. OPTION	
		N/A	
		530	

* Maximum Units Allowed with P.R.D. Bonus

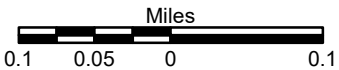
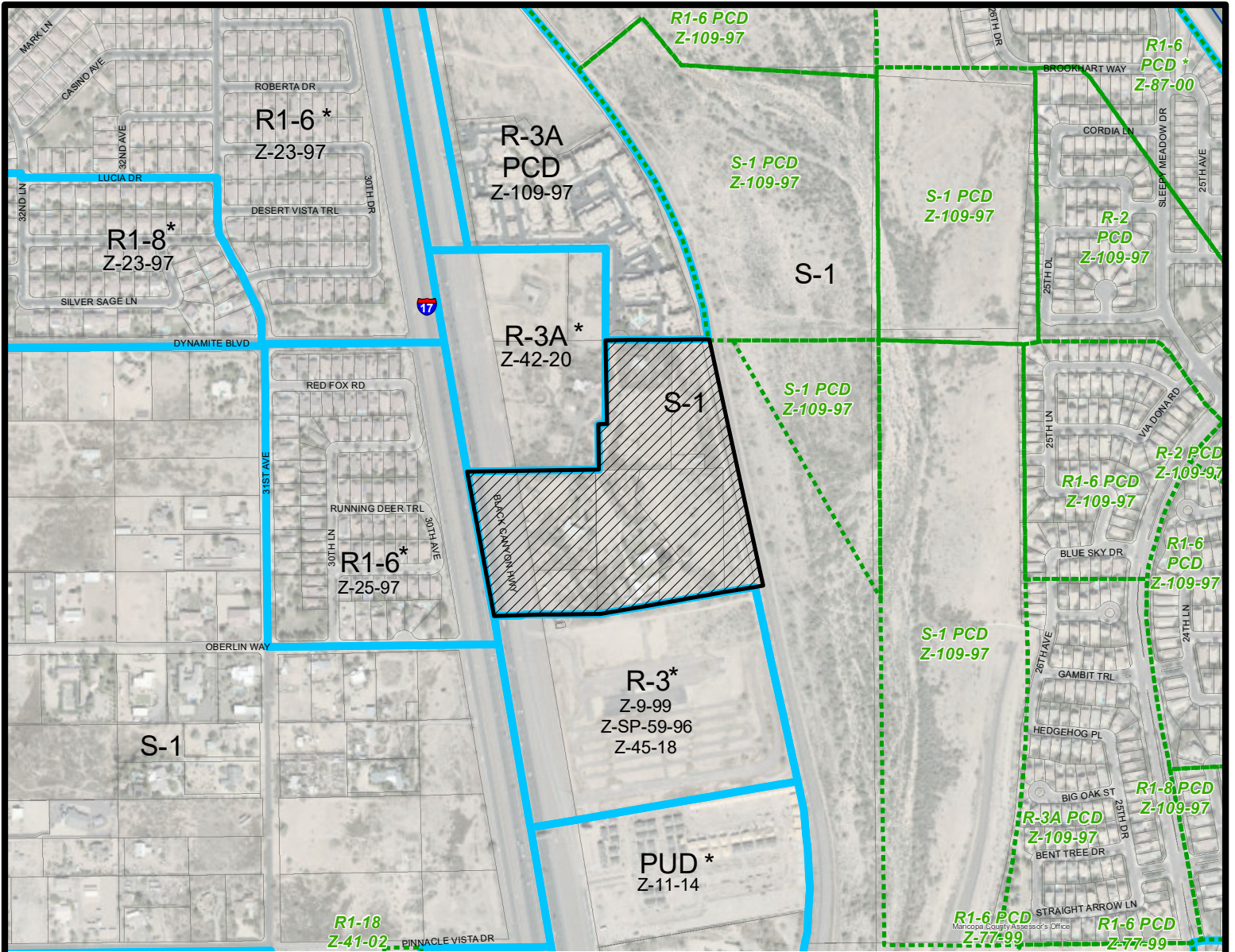

DEER VALLEY VILLAGE
CITY COUNCIL DISTRICT: 2

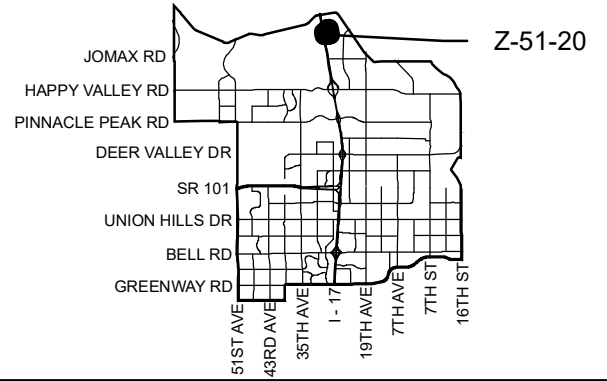

APPLICANT'S NAME: **Chuck Chisholm, K Hovnanian Homes**

REQUESTED CHANGE:

FROM: **S-1 (20.08 a.c.)**

APPLICATION NO. **Z-51-20**

DATE: **11/19/2020**
REVISION DATES:

GROSS AREA INCLUDING 1/2 STREET AND ALLEY DEDICATION IS APPROX.

20.08 Acres

AERIAL PHOTO & QUARTER SEC. NO. **QS 50-22**
ZONING MAP **P-7**

TO: **R-3A (20.08 a.c.)**

MULTIPLES PERMITTED

S-1

R-3A

CONVENTIONAL OPTION

20

442

*** UNITS P.R.D. OPTION**

N/A

530

* **Maximum Units Allowed with P.R.D. Bonus**

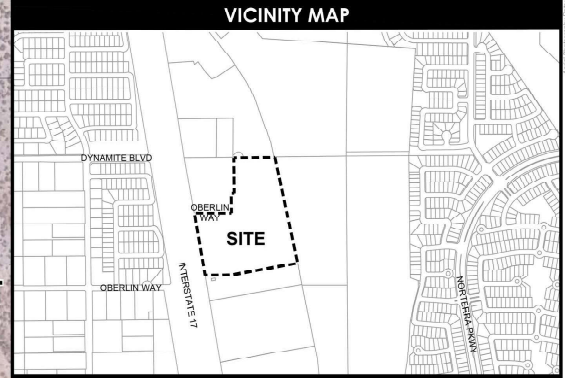

PROJECT TEAM

DEVELOPER K. HOVNIANIAN HOMES CHUCK CHISHOLM 20830 N. TATUM BLVD. SUITE 200 PHOENIX, AZ 85050 PHONE: (480) 824-4175 CCHISHOLM@KHUV.COM	PLANNER RVI PLANNING ALEX STEDMAN 120 S. ASH AVE SUITE 200 TEMPE, AZ 85281 PHONE: (480)994-0994 ASTEDMAN@RVIPLANNING.COM	ATTORNEY SNELL & WILMER NICK WOOD ONE ARIZONA CENTER 400 EAST VAN BUREN ST SUITE 1900 PHOENIX, AZ 85004-2202 PHONE: (602) 382-2202 NWOOD@SWLAW.COM
--	--	---

SITE DATA

--- (dashed line)	SITE BOUNDARY
--- (dashed line)	TRASH ROUTE
APNs:	205-01-011R, 205-01-011S, 205-01-011X, 205-01-011H, 205-01-011K, 205-01-012A, 205-01-011W, 205-01-011V
EXISTING ZONING:	S 1
PROPOSED ZONING:	R-3A (PRD)
GROSS AREA:	17.6 AC
PROPOSED USE:	10W/HOMES (3, 4, & 5 PACKS)
MAXIMUM BUILDING HEIGHT:	30' / TWO-STORIES
MINIMUM LOT SIZE:	20'x60'
MINIMUM PRODUCT SIZE:	20'x44'
BACKYARD DEPTH:	10'
MAXIMUM NUMBER OF UNITS:	285
MAXIMUM DENSITY:	14.5 DU/AC
PERCENT OPEN SPACE:	28%
PERIMETER SETBACKS:	
ADJ. TO PROPERTY LINE	=15'
ADJ. TO PUBLIC STREET	=20'
ADJ. TO I17 FRONTAGE	=25'
BUILDING SETBACK:	=10'

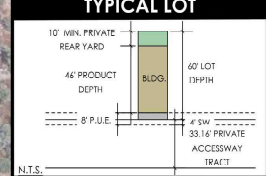
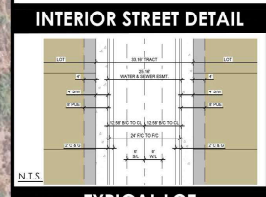

APPROVALS

CITY OF PHOENIX

FEB 12 2021

Planning & Development Department

Information furnished regarding this project is for informational purposes only. It is not intended to constitute an offer of any financial product or service. RVI Planning, Inc. makes no representation, investigation of, or warranty of any kind, in connection with this information. RVI Planning, Inc. is not responsible for any errors or omissions in this information. This information is subject to change, and does not represent any regulatory approval.

17 NORTH • SITE PLAN



BUILDING 4 - (4-PLEX B)

BUILDING 1 - (3-PLEX A)

BUILDING 6 - (5-PLEX B)

STREET SCENE



SERIES WIDTH
20'

LIV. SF: N/A
PLAN WIDTH: N/A
BUILDING: 1 (3-PLEX A)
MODERN FARMHOUSE

'MODERN FARMHOUSE'
FRONT VIEW: N.T.S.

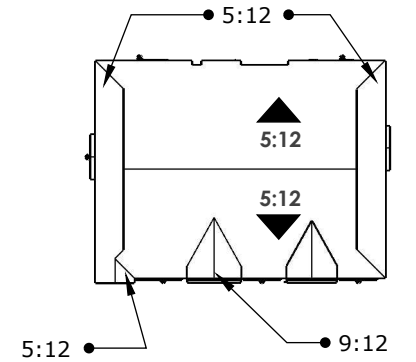

ROOF PLAN
SCALE: N.T.S.

STYLE LEGEND:

- 1 PROMINENT GABLES
- 2 ARCHITECTURAL SHINGLES
- 3 2" RAKES AND EAVES
- 4 STUCCO CONTROL JOINTS
- 5 BOARD AND BATTEN ACCENTS
- 6 WOOD FASCIA

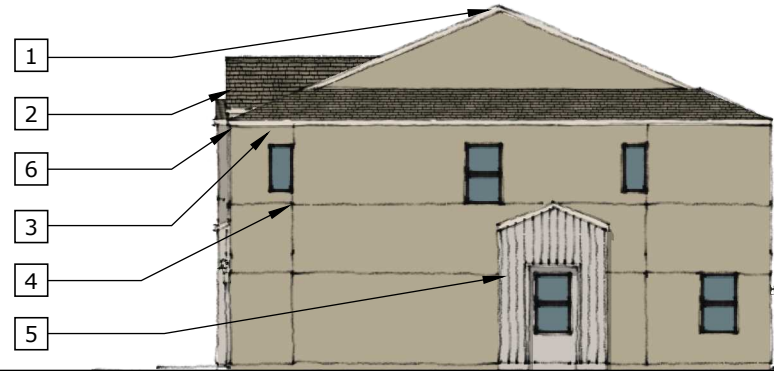

RIGHT ELEVATION
SCALE: 1/16" = 1'-0"

UNIT 4
(PLAN #1219)



REAR ELEVATION
SCALE: 1/16" = 1'-0"

UNIT 4 (PLAN #1219) UNIT 2A (PLAN #1216) UNIT 1 (PLAN #1215)

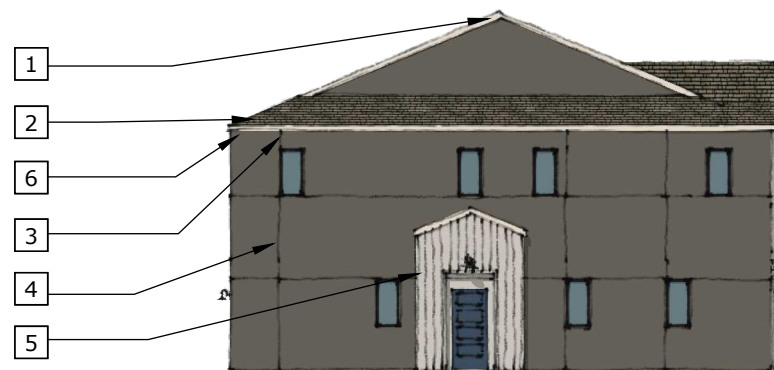

LEFT ELEVATION
SCALE: 1/16" = 1'-0"

UNIT 1
(PLAN #1215)

- T.O. RIDGE
29'-6"
- T.O. PLATE
9'-1" A.S.F.F.
- T.O. PLATE
9'-1" A.F.F.F.



FRONT ELEVATION
SCALE: 1/16" = 1'-0"

UNIT 1 (PLAN #1215) UNIT 2A (PLAN #1216) UNIT 4 (PLAN #1219)

SERIES WIDTH
20'

LIV. SF: N/A
PLAN WIDTH: N/A
BUILDING: 2 (3-PLEX B)
MODERN FARMHOUSE



'MODERN FARMHOUSE'
FRONT VIEW: N.T.S.

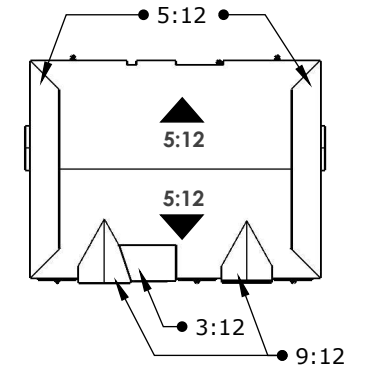

ROOF PLAN
SCALE: N.T.S.

STYLE LEGEND:

- 1 PROMINENT GABLES
- 2 ARCHITECTURAL SHINGLES
- 3 0"/12" RAKES AND 14" EAVES
- 4 STUCCO CONTROL JOINTS
- 5 BOARD AND BATTEN ACCENTS
- 6 WOOD FASCIA

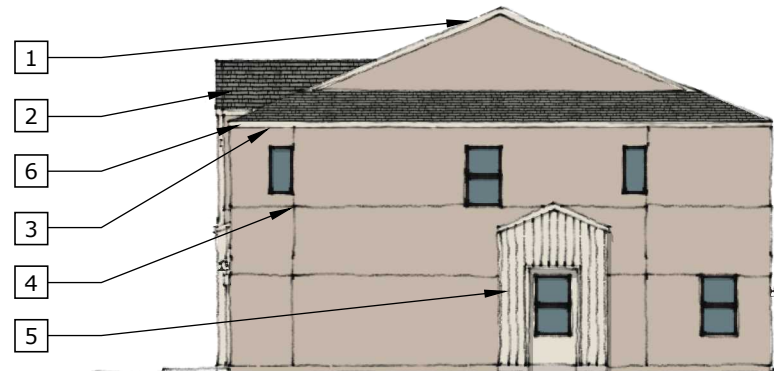

RIGHT ELEVATION
SCALE: 1/16" = 1'-0"

UNIT 4
(PLAN #1219)



REAR ELEVATION
SCALE: 1/16" = 1'-0"

UNIT 4 (PLAN #1219) UNIT 2A (PLAN #1216) UNIT 4 (PLAN #1219)

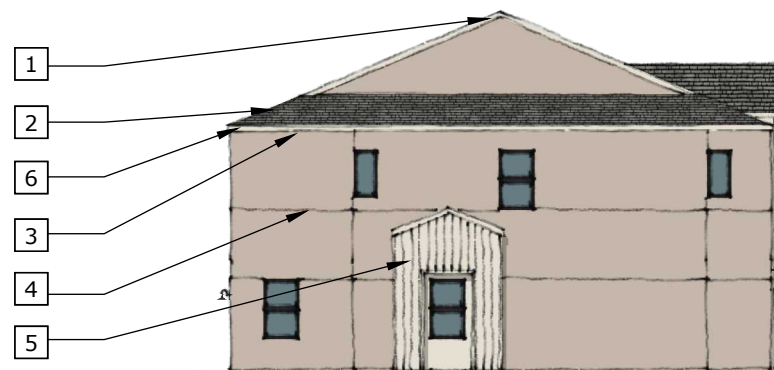

LEFT ELEVATION
SCALE: 1/16" = 1'-0"

UNIT 4
(PLAN #1219)



FRONT ELEVATION
SCALE: 1/16" = 1'-0"

UNIT 4 (PLAN #1219) UNIT 2A (PLAN #1216) UNIT 4 (PLAN #1219)

SERIES WIDTH
20'

LIV. SF: N/A
PLAN WIDTH: N/A
BUILDING: 3 (4-PLEX A)
MODERN FARMHOUSE



'MODERN FARMHOUSE'
FRONT VIEW: N.T.S.

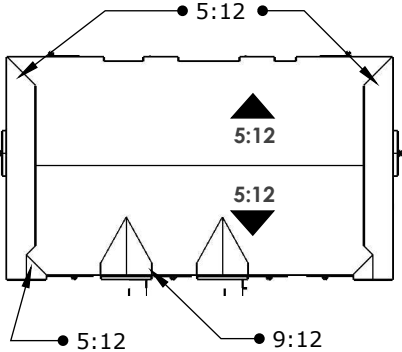

ROOF PLAN
SCALE: N.T.S.

- STYLE LEGEND:**
- 1 PROMINENT GABLES
 - 2 ARCHITECTURAL SHINGLES
 - 3 2" RAKES AND EAVES
 - 4 STUCCO CONTROL JOINTS
 - 5 BOARD AND BATTEN ACCENTS
 - 6 WOOD FASCIA

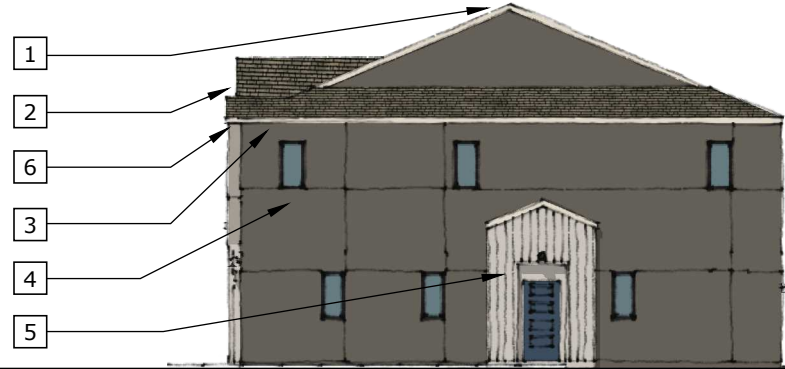

UNIT 1
(PLAN #1215)

RIGHT ELEVATION
SCALE: 1/16" = 1'-0"



UNIT 1 (PLAN #1215) UNIT 3 (PLAN #1218) UNIT 3 (PLAN #1218) UNIT 1 (PLAN #1215)

REAR ELEVATION
SCALE: 1/16" = 1'-0"

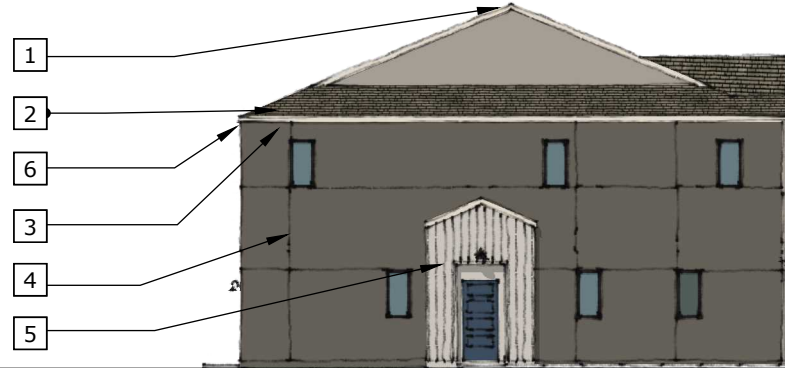

UNIT 1
(PLAN #1215)

LEFT ELEVATION
SCALE: 1/16" = 1'-0"

- T.O. RIDGE
29'-6"
- T.O. PLATE
9'-1" A.S.F.F.
- T.O. PLATE
9'-1" A.F.F.F.



UNIT 1 (PLAN #1215) UNIT 3 (PLAN #1218) UNIT 3 (PLAN #1218) UNIT 1 (PLAN #1215)

FRONT ELEVATION
SCALE: 1/16" = 1'-0"

SERIES WIDTH
20'

LIV. SF: N/A
PLAN WIDTH: N/A
BUILDING: 4 (4-PLEX B)
MODERN FARMHOUSE



'MODERN FARMHOUSE'
FRONT VIEW: N.T.S.

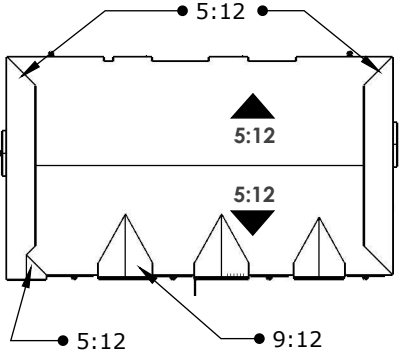

ROOF PLAN
SCALE: N.T.S.

STYLE LEGEND:

- 1 PROMINENT GABLES
- 2 ARCHITECTURAL SHINGLES
- 3 0"/12" RAKES AND 14" EAVES
- 4 STUCCO CONTROL JOINTS
- 5 BOARD AND BATTEN ACCENTS
- 6 WOOD FASCIA

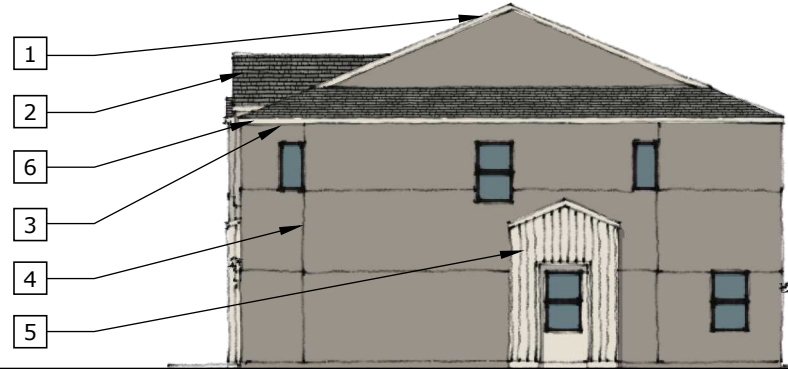

RIGHT ELEVATION
SCALE: 1/16" = 1'-0"

UNIT 4
(PLAN #1219)



REAR ELEVATION
SCALE: 1/16" = 1'-0"

UNIT 4 (PLAN #1219) UNIT 2A (PLAN #1216) UNIT 2A (PLAN #1216) UNIT 1 (PLAN #1215)

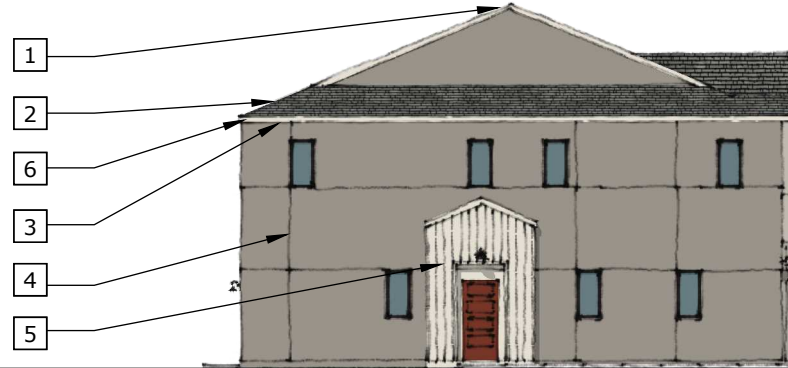

LEFT ELEVATION
SCALE: 1/16" = 1'-0"

UNIT 1
(PLAN #1215)

- T.O. RIDGE
29'-6"
- T.O. PLATE
9'-1" A.S.F.F.
- T.O. PLATE
9'-1" A.F.F.F.



FRONT ELEVATION
SCALE: 1/16" = 1'-0"

UNIT 1 (PLAN #1215) UNIT 2A (PLAN #1216) UNIT 2A (PLAN #1216) UNIT 4 (PLAN #1219)

SERIES WIDTH
20'

LIV. SF: N/A
PLAN WIDTH: N/A
BUILDING: 5 (5-PLEX A)
MODERN FARMHOUSE

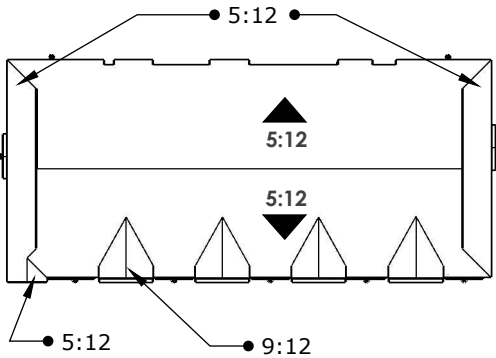

ROOF PLAN
SCALE: N.T.S.

STYLE LEGEND:

- 1 PROMINENT GABLES
- 2 ARCHITECTURAL SHINGLES
- 3 2" RAKES AND EAVES
- 4 STUCCO CONTROL JOINTS
- 5 BOARD AND BATTEN ACCENTS
- 6 WOOD FASCIA

'MODERN FARMHOUSE'
FRONT VIEW: N.T.S.

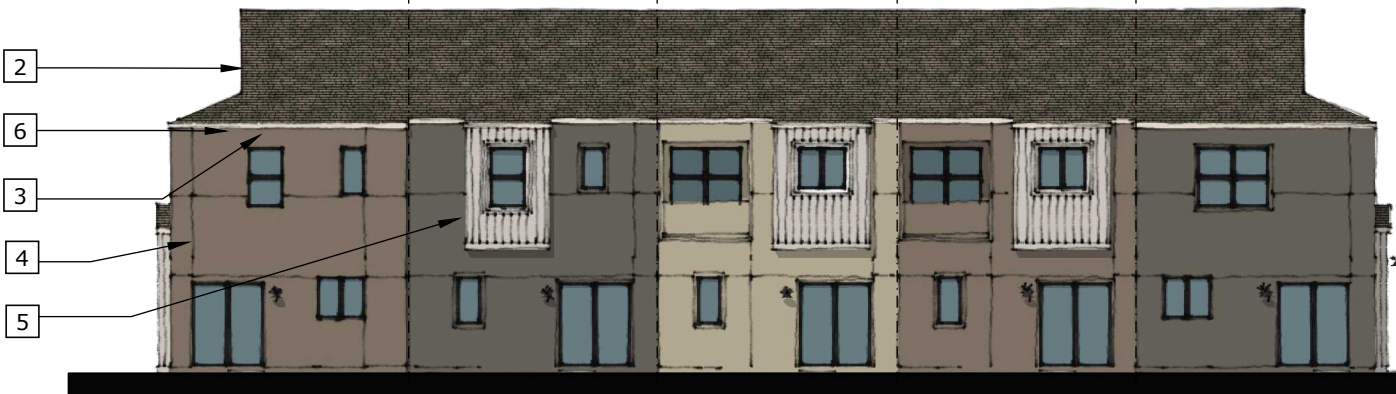

REAR ELEVATION
SCALE: 1/16" = 1'-0"

UNIT 4 (PLAN #1219) UNIT 3 (PLAN #1218) UNIT 2A (PLAN #1216) UNIT 2B (PLAN #1217) UNIT 1 (PLAN #1215)

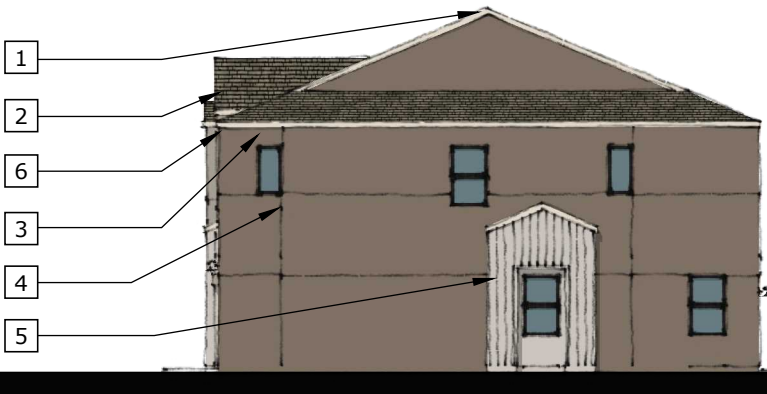

RIGHT ELEVATION
SCALE: 1/16" = 1'-0"

UNIT 4
(PLAN #1219)

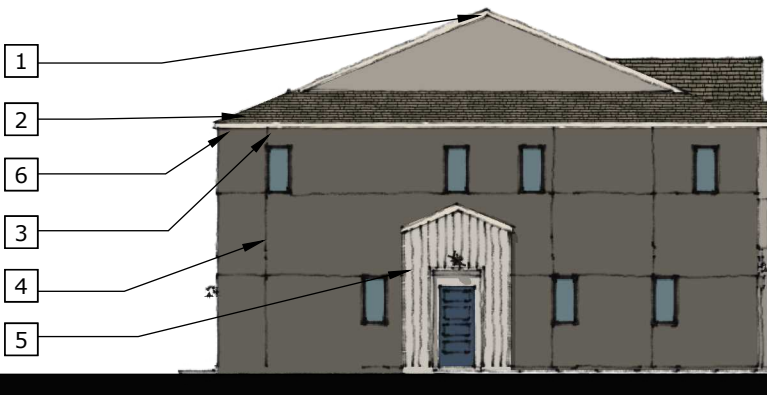

LEFT ELEVATION
SCALE: 1/16" = 1'-0"

UNIT 1
(PLAN #1215)

- T.O. RIDGE 29'-6"
- T.O. PLATE 9'-1" A.S.F.F.
- T.O. PLATE 9'-1" A.F.F.F.



FRONT ELEVATION
SCALE: 1/16" = 1'-0"

UNIT 1 (PLAN #1215) UNIT 2B (PLAN #1217) UNIT 2A (PLAN #1216) UNIT 3 (PLAN #1218) UNIT 4 (PLAN #1219)

SERIES WIDTH
20'

LIV. SF: N/A
PLAN WIDTH: N/A
BUILDING: 6 (5-PLEX B)
MODERN FARMHOUSE

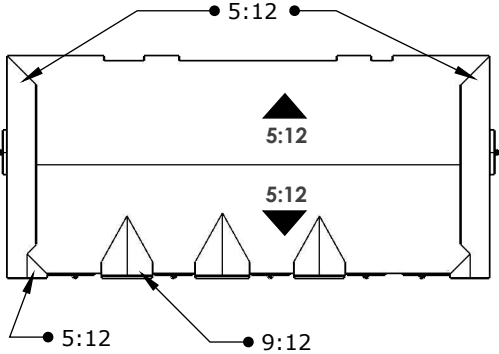

ROOF PLAN
SCALE: N.T.S.

STYLE LEGEND:

- 1 PROMINENT GABLES
- 2 ARCHITECTURAL SHINGLES
- 3 0"/12" RAKES AND 14" EAVES
- 4 STUCCO CONTROL JOINTS
- 5 BOARD AND BATTEN ACCENTS
- 6 WOOD FASCIA

'MODERN FARMHOUSE'
FRONT VIEW: N.T.S.



RIGHT ELEVATION
SCALE: 1/16" = 1'-0"

UNIT 1
(PLAN #1215)



REAR ELEVATION
SCALE: 1/16" = 1'-0"

UNIT 1 (PLAN #1215) UNIT 3 (PLAN #1218) UNIT 2A (PLAN #1216) UNIT 3 (PLAN #1218) UNIT 1 (PLAN #1215)

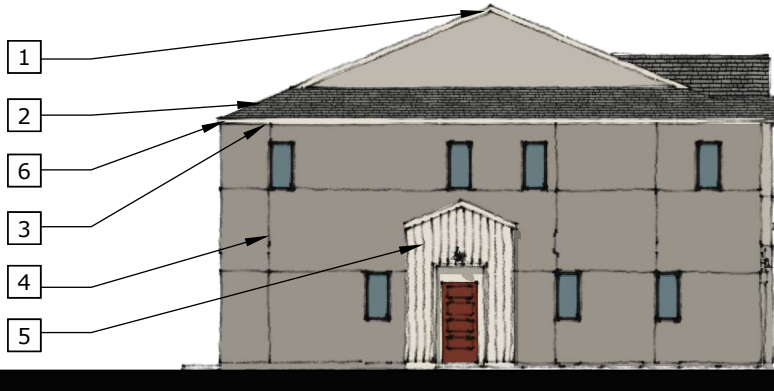

LEFT ELEVATION
SCALE: 1/16" = 1'-0"

UNIT 1
(PLAN #1215)



FRONT ELEVATION
SCALE: 1/16" = 1'-0"

UNIT 1 (PLAN #1215) UNIT 3 (PLAN #1218) UNIT 2A (PLAN #1216) UNIT 3 (PLAN #1218) UNIT 1 (PLAN #1215)

- T.O. RIDGE
29'-6"
- T.O. PLATE
9'-1" A.S.F.F.
- T.O. PLATE
9'-1" A.F.F.F.