



City of Phoenix

PLANNING AND DEVELOPMENT SERVICES

Staff Report Z-TA-8-09 **Zoning Ordinance Text Amendment** February, 23, 2015

Application Z-TA-8-09: Request to amend the Phoenix Zoning Ordinance to create a new Chapter 13 (Walkable Urban Code) to implement the visions and goals and policies of the Gateway, Eastlake-Garfield, Midtown, Uptown and Solano Transit Oriented District Policy Plans.

Staff Recommendation: Staff recommends approval of Z-TA-8-09 as shown in the recommended text in Attachment A of the staff report.

Village Planning Committee Recommendations

Encanto, March 2, 2015 -
Central City, March 9, 2015 -
Alhambra, March 24, 2015 –
Camelback East, April 7, 2105 -

Design Standards Committee Recommendation

March 26, 2015 -

BACKGROUND

In order to address the visions, goals and policies contained in the five Transit Oriented District Policy Plans, to the extent possible within our current regulatory environment, a new zoning code has been developed that establishes a comprehensive set of standards and guidelines designed for the urban environment.

The Walkable Urban (WU Code) has been drafted to address Proposition 207 which states that new zoning cannot diminish the value of private property. Existing entitlements have been preserved and while new standards and guidelines to promote a vibrant urban environment are being proposed, the total package of land use and development standards will ensure equal or greater development capacity compared to that which currently exists.

The City of Phoenix Zoning Map will adopt, through the public hearing process, transect districts for properties located within the boundaries of the five Transit Oriented District Policy Plans and will replace the Interim Transit Oriented Development Overlay Districts (TOD-1 and TOD-2). The mapping process will outreach to neighborhood groups and property owners, as part of the public hearing process in the Fall of 2015. The WU code will not be mapped with this text amendment or with any of the five Transit Oriented District Policy Plans.

WALKABLE URBAN CODE SUMMARY

The WU Code is a new form-based zoning code – the implementation zoning tool that will guide development, shape future growth, and help realize the city’s vision for sustainable transit and pedestrian-oriented development along the Light Rail Corridor within the Reivent Phx area.

The WU Code has been developed as a Transect-based code which is designed for the urban environment, and can better address the relationship between building facades and the public realm by providing standards and guidelines that encourage and reinforce the development of vibrant and walkable urban neighborhoods.

The code’s individual sections provide guidance for all standards, while specifically addressing frontage, shade, land uses, reduced parking requirements, and alternative design options, as described below.

CODE ADMINISTRATION

This section provides the purpose and intent for the code and the language that ensures that land uses and all current entitlement, non-conformities, and Historic Preservation provisions are addressed.

TRANSECT DISTRICTS AND STANDARDS

The Transect Districts included in the WU Code are T3, T4, T5 and T6. Each district identifies the intensity level of development, ranging from a low-intensity and more residential fabric (T3, T4), to a medium and high intensity mixed use fabric (T5, T6). A Height Waiver transect (T6:HWR) will address existing high intensity development or sites with additional height to respect existing property entitlements.

An additional transect, the Special District (SD), will be assigned to projects that are regulated by special plans, or that by their nature, function, entitlements or size, cannot conform to the requirements of any transect or combinations of transects. There are 12 Transect Districts and one Special District included in the WU Code.

The Lot Standards Section provides requirements for building placement, setbacks, maximum height, frontage types and glazing. It also includes additional setback and stepback requirements for higher intensity development when adjacent to existing single-family zoning districts and Historic Preservation properties and districts.

GENERAL SITE DEVELOPMENT

This section focuses on standards that reinforce the development of a vibrant pedestrian environment through building design, shade, and pedestrian paseos. In addition, new Large Scale Development standards address pedestrian connectivity, block sizes, and requirements for a mix of housing and mixed-use types.

FRONTAGE TYPES

Frontage Types were originally developed for the Downtown Code as a means to create a more vibrant pedestrian downtown, and frontages types are the primary way by which the WU Code will address the relationship between the building façade and the street in a transit oriented environment.

This section also provides staff the flexibility to modify requirements when there is a conflict with public utility easements and for the approval of innovative, alternative frontage designs as long as the design meets the intent of the code for pedestrian and transit-oriented frontages and façades.

LAND USES

The land uses allowed within the boundaries of the WU Code are provided in a Land Use Matrix – uses are permitted either by right, with conditions, or with a use permit in each transect sub-district. The matrix is divided into use categories with related land use conditions when applicable.

PARKING

The parking standards in this section provide a balance between the demands of an existing corridor's auto-oriented development pattern and the ultimate transition to transit-oriented development in support of the existing light rail investment.

In order to promote adaptive reuse, redevelopment and the use of transit and other modes of transportation, reduced parking requirements are proposed per use category, such as affordable housing. Processes are identified to further reduce the requirements under specified circumstances and through shared parking. Standards for bicycle parking and related amenities are also included in this section.

SIGNAGE

Signage standards are designed to contribute to, rather than detract from, the walkable environment. A provision for the Historic Preservation Commission to allow originally permitted wall signs on buildings with Historic Preservation designation that exceed the size regulations is included.

LANDSCAPING

Landscaping standards and the permitted Shade Tree Matrix are designed to provide shade for pedestrians as well as buffers when adjacent to single-family residential zoning districts and Historic Preservation properties and districts.

OPEN SPACE IMPROVEMENTS

Public open space standards and improvements to the streetscape adjacent to a development are covered in this section.

CHARACTER AREAS

This section is divided by character areas which corresponds to each of the five transit oriented districts and it is designed to address standards and special considerations that apply only within the boundaries of each of the five districts, such as the general commercial and industrial uses in the Gateway and Eastlake-Garfield districts.

DESIGN DEVELOPMENT CONSIDERATIONS

When there are requests made to deviate from the standards identified in the WU Code, the Design Development Considerations provide objectives and considerations for use in evaluating those requests. Considerations include walking and bicycling, transit use, personal safety, access to light and air, parking, signage and providing for an active pedestrian-oriented realm and to cool streets, sidewalks and buildings.

DESIGN AND STANDARDS ALTERNATIVES

An important goal of the WU Code is the promotion of design excellence. One way the WU Code furthers this goal is by including the Design Alternative process. This process creates flexibility and encourages innovative responses to the development standards and guidelines of the Code, as long as the alternatives demonstrate conformance with the goals and intent of the WU Code and the Policy Plans.

This section provides standards for the approval of Design Alternatives by the Planning and Development Department (PDD) staff and by the Design Review Committee (DRC). The process may be used to modify frontage types, design guidelines, or deviate up to a total of 25 percent from a development standard as prescribed in the code.

PDD staff may modify certain standards and design guidelines to accommodate existing conditions or a design alternative, under consultation with the PDD Director or designee. This allows staff to work with the developer to find appropriate solutions whenever possible.

If design alternatives cannot be approved by staff, the applicant may file an appeal with the DRC. The DRC oversees the appeal process and may approve design alternatives and standards beyond the scope of PDD staff approval.

CONCLUSION

The Walkable Urban Code has involved a tremendous effort by PDD staff, as well as the Design Standards Committee (DSC). The DSC met several times to review the code and assist staff in evaluating complex new standards and guidelines proposed for the code to full implementation.

In order to seek public input, staff held work-study sessions for Design and Law Professionals, Historic Neighborhoods, Village Planning Committees and the Historic Preservation Commission, and also met with individual stakeholders. Finally, guidance for the code also emerged from the Reinvent Phx process and the Transit Oriented District Policy Plans, which defined the unique character of each transit area.

ATTACHMENT A

Z-TA-8-09

PROPOSED ORDINANCE TEXT

Staff Proposed Language That May Be Modified During the Public Hearing Process:

CHAPTER 13 – WALKABLE URBAN CODE – CITY OF PHOENIX

TABLE OF CONTENTS

| | | |
|---------------|------------------------------------|----|
| Section 1301. | Code Administration | 02 |
| Section 1302. | Transect Districts | 05 |
| Section 1303. | Transect Lot Standards | 07 |
| Section 1304. | General Site Development Standards | 18 |
| Section 1305. | Frontage Standards | 23 |
| Section 1306. | Land Use Matrix | 31 |
| Section 1307. | Parking Standards | 42 |
| Section 1308. | Signage Standards | 50 |
| Section 1309. | Landscape Standards | 57 |
| Section 1310. | Open Space Improvements | 62 |
| Section 1311. | Design Development Considerations | 64 |
| Section 1312. | Character Areas | 67 |
| Section 1313. | Design and Standards Alternative | 75 |

SECTION 1301: CODE ADMINISTRATION

A. Title.

The regulations within this Chapter are known as the “Walkable Urban Code,” and referred to in their entirety as “WU Code” or “this Chapter” throughout Chapter 13.

B. Purpose and Intent.

1. The primary purpose of this Chapter is to implement the vision and policies of the Transit Oriented District (TOD) Policy Plans for Gateway, Eastlake-Garfield, Midtown, Uptown and Solano, and encourage an appropriate mixture and density of activity around transit stations, to increase transit ridership in general and along the Central Phoenix/East Valley Light Rail Corridor in particular; and to promote multiple modes of transportation. The secondary purpose of the Code is to improve pedestrian safety from crime, to avoid or mitigate nuisances, to promote the public health, to decrease automobile-dependence, and to mitigate the effects of congestion and pollution. These regulations seek to achieve these purposes by providing the following:
 - a. An increase of population and employment through infill development within transit-oriented districts;
 - b. A pedestrian, bicycle, and transit supportive development environment;
 - c. The integration of auto-oriented and industrial uses with a complementary mix of land uses;
 - d. A high level of connectivity of pedestrian and vehicular routes, which entails small block sizes;
 - e. Comfortable, safe, and economically productive districts surrounding light rail stations, providing for walking and bicycling between addresses in and around transect districts; and
 - f. The protection of property value.

C. Applicability. The Walkable Urban Code may be applied and is limited to land uses, subdivisions, and development within the ReinventPHX Transit Oriented

District Policy Plans for Gateway, Eastlake-Garfield, Midtown, Uptown and Solano. The boundaries of these areas are shown in the District Maps located in the Transit Oriented District Policy Plans for Gateway, Eastlake-Garfield, Solano, Midtown and Uptown.

1. When in conflict, text and numerical metrics in tables shall take precedence over diagrams and illustrations.
2. The Zoning Ordinance of the City of Phoenix applies in its entirety for properties subject to Chapter 13 except as follows:
 - a. If a conflict occurs between requirements of the WU Code and the City of Phoenix Zoning Ordinance, the requirements of the WU Code shall prevail.
 - b. Properties with Historic Preservation (HP) zoning are subject to the provisions of Chapter 8, Historic Preservation, of the Phoenix Zoning Ordinance. In the event of a conflict between the provisions of Chapter 8 and Chapter 13, the provisions of Chapter 8 shall prevail.

D. Approval Requirements.

1. Development review approval must be obtained in accordance with Section 507 of The Zoning Ordinance of the City of Phoenix demonstrating compliance with the development standards and guidelines of this code.
2. Any deviation from the WU Code standards or guidelines shall be approved in accordance with Section 1313. Design and Standards Alternatives.
3. Development plans submitted as Master Plans shall demonstrate compliance with the WU Code and in general conformance with Conceptual Master Plans within the TOD Policy Plan for the development area, as per Section 1304.G.2.
4. Gateway properties within the TOD Policy Plans that were zoned Commercial C-3 and A-1 Light Industrial districts prior to the time of rezoning to the WU Code, are allowed to have general commercial, industrial or manufacturing uses shown in Sections 1312.A.

5. Existing structures and land uses established legally at the time of adoption of this Code shall be subject to the provisions of Chapter 9, Nonconformities, of the Phoenix Zoning Ordinance if they do not meet the regulations in Chapter 13.
6. Walkable Urban Code building design and shade structures are allowed reduced requirements if the WU Code conflicts with the City of Phoenix adopted Building Code and the design meets the Building Code.

SECTION 1302 TRANSECT DISTRICTS

A. The Transect. The Transect, as a framework, identifies a range of standards that encourage development that supports the levels of diversity, intensity and form that best integrate with surrounding neighborhoods while facilitating urban, pedestrian supported transit oriented projects.

The City of Phoenix Walkable Urban Code consists of 12 transect districts and a special district option. These transect districts vary by the level and intensity of their physical and social character, providing immersive contexts from less intense to more intense urban development.

1. The following transect districts are created based on each district's intensity of development, coordinating use, height, setback, parking location, streetscape, and other built elements:
 - a. T3:2 District. Low-intensity residential fabric characterized primarily by single-family homes and duplexes in relatively large lots with deep setbacks. Home occupations are permitted.
 - b. T4:2 and T4:3 Districts. Low-intensity urban residential fabric characterized by single-family homes, duplexes, single-family attached and small multifamily developments, averaging from two to four stories. Home occupations are permitted.
 - c. T5:2 and T5:3 Districts. Low-intensity urban mixed-use fabric characterized by small main street scale commercial areas, adaptive reuse of single family homes to retail, office uses and dining establishments, and mixed use residential developments incorporating a broad mix of frontage types, averaging two to four stories.
 - d. T5:5, T5:6 and T5:7 Districts. A medium-high-intensity mixed-use fabric characterized by a broad mix of buildings that integrate retail, offices, live-work and residential units adjacent to the Light Rail Corridor, averaging 5 to 10 stories.
 - e. T6:7, T6:15 and T6:22 Districts. A high-intensity mixed-use urban fabric characterized by large footprint high rise buildings averaging 10 to 22 stories in height adjacent to the Light Rail Corridor. Buildings have the highest intensity of uses, integrating office,

commercial and residential uses. Development may incorporate forecourts and open spaces available to the public.

- f. T6:HWR District. A height waiver, high-intensity fabric characterized by mixed-use buildings with large footprints and or towers with existing and any new height waiver entitlements beyond T6:22.
- g. Special Districts (SD). Assigned to sites that, by their intrinsic size, function, configuration, or approved entitlements, cannot conform to or be regulated by the requirements of any transect or combinations of transects, or when existing development is regulated by special plans. Special districts are reserved for functions including but are not limited to hospitals, colleges and universities, civic spaces, transportation facilities and airports.

B. Transect District Boundaries

- 1. Where uncertainty exists as to the boundaries of the transect districts shown on the Zoning Map, the following rules apply:
 - a. Where a transect district boundary is located within or along a right-of-way, the boundary line is deemed to be along the centerline of the right-of-way.
 - b. Where a transect district boundary is shown as approximately following lot lines, the boundary line is deemed to coincide with such lot lines.

SECTION 1303 TRANSECT LOT STANDARDS

A. General Lot Standards

1. The Single-Family Attached development option (SFA) is allowed in all transect districts except T3:2 and must meet Sections 608.F.5 and 615 Table B. of the Zoning Ordinance.
2. Development in T4, T5 and T6 shall follow the same setback and stepback standards as the Single-Family Attached development option. If development is adjacent to a Single-Family zoning district (Sections 613) or Historic Preservation designated property or district the following additional requirements shall apply:
 - a. Minimum 10-foot landscape-setback.
 - (1) Single-family detached dwellings excluded.
 - b. Stepback provision shall not exceed maximum 75-foot setback from rear and side property lines for building height before maximum height allowed.
3. The minimum side and rear yard setback requirements in Table 1303.1 shall apply to all structures 48-foot height or greater:

| TABLE 1303.1 SETBACK REQUIREMENTS. BUILDINGS OVER 48 FEET. | |
|---|--|
| BUILDING HEIGHT | REAR AND SIDE SETBACKS, if adjacent to the following: R1-10, R1-8, R1-6, and Historic Preservation properties and districts. |
| 48+'—70' | Minimum 25-foot building setback from property line. |
| 70+' and above | Minimum 30-foot building setback from property line plus one-foot setback for each two-foot increase in height, up to 75' setback. |

4. Modifications per Section 1312. Character Areas.
5. Height Restrictions
 - a. In no event can the height exceed the airport height limit in accordance with FAA height restrictions.

6. Primary Frontages. Lot lines abutting a right-of-way are designated as primary frontage line or secondary frontage line as follows:
 - a. For lots abutting a right-of-way along a single lot line, the abutting lot line is designated the primary frontage.
 - b. For lots abutting rights-of-way along multiple lot lines the primary frontage is designated by the Planning and Development Department, all remaining frontages are designated secondary frontages.
 - c. For through lots, primary frontage requirements pertain to frontages on both thoroughfares.

B. Transect Setbacks and Lot Standards

TABLE 1303.2 TRANSECT T3
BUILDING LOT STANDARDS

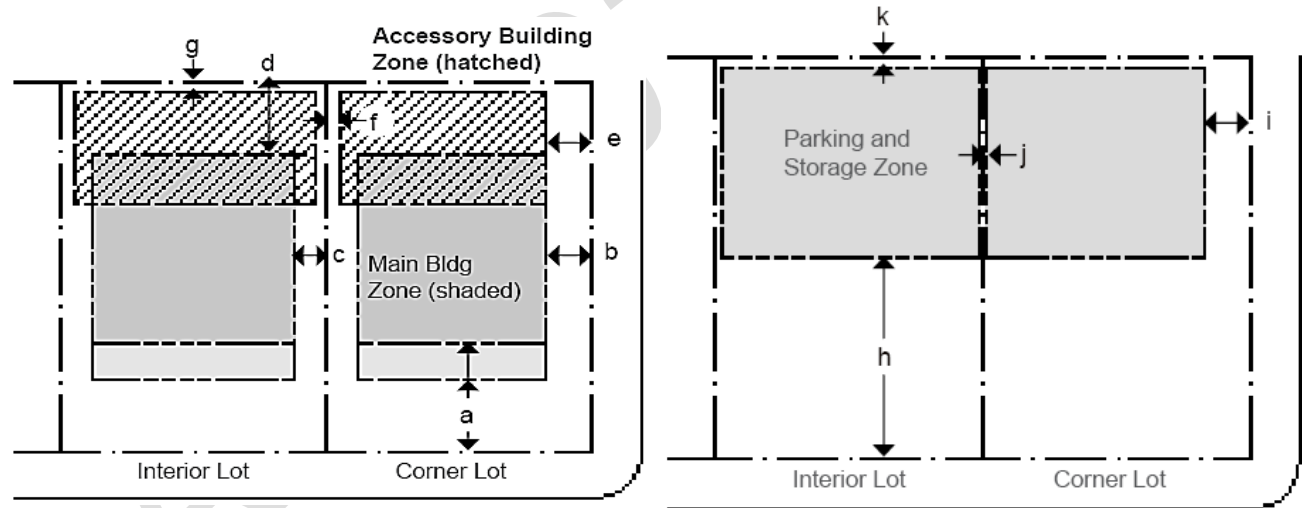

| MAIN BUILDING SETBACKS | | | PARKING SETBACKS | | |
|------------------------|--------------------|----------------------------|------------------|--------------------|-----------------|
| a | Primary Frontage | 20-foot minimum | h | Primary Frontage | 30-foot minimum |
| b | Secondary Frontage | 12-foot minimum | i | Secondary Frontage | 8-foot minimum |
| c | Side Lot Line | 3-foot and 10-foot minimum | j | Side Lot Line | 5-foot minimum |
| d | Rear Lot Line | 20-foot minimum | k | Rear Lot Line | 5-foot minimum |

TABLE 1303.2 TRANSECT T3

| ACCESSORY BUILDING SETBACKS | | | LOT REQUIREMENTS | |
|-----------------------------|--------------------|-----------------|-----------------------------|-------------|
| e | Secondary Frontage | 12-foot minimum | Lot Coverage* | 60% maximum |
| f | Side Lot Line | 5- foot minimum | Primary Building Frontage | 50% minimum |
| g | Rear Lot Line | 3-foot minimum | Secondary Building Frontage | n/a |

BUILDING FRONTAGE

FRONTAGE TYPES ALLOWED

| | |
|--------------------|---|
| Primary Frontage | Porch, patio, stoop or alternative frontages as per Section 1305.B.1.c. |
| Secondary Frontage | Porch, patio, stoop, alternative frontages as per Section 1305.B.1.c. or none |
| Entry Requirements | Building entries are not required along secondary frontages |

MINIMUM GLAZING ON RESIDENTIAL BUILDING FRONTAGES FACING STREET RIGHT-OF-WAY.

| | |
|--------------|-----------------------|
| Ground Floor | 20% |
| Second Floor | 20%, 5% East and West |
| Upper Floors | n/a |

BUILDING HEIGHT

| | | |
|---|---------------------|-----------------|
| a | Main Building | 30-foot maximum |
| b | Accessory Buildings | 30-foot maximum |

* Lot coverage maximum may be modified for SFA development option

TABLE 1303.2 TRANSECT T4
BUILDING LOT STANDARDS

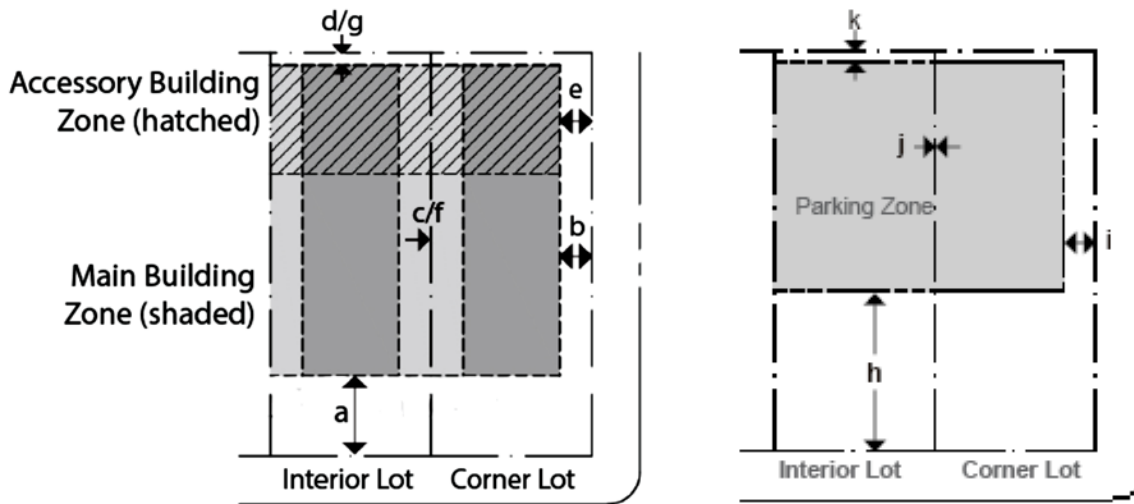

| MAIN BUILDING SETBACKS | | PARKING SETBACKS | |
|--|------------------------------|---|---------------------------------------|
| a | Primary Frontage | 20-foot maximum | |
| b | Secondary Frontage | 8-foot maximum | |
| c | Side Lot Line ⁽¹⁾ | 0-foot minimum | |
| d | Rear Lot Line ⁽¹⁾ | 0-foot minimum | |
| ⁽¹⁾ Setbacks requirements as per Section 1303.A.2. when adjacent to single-family residential districts and historic properties or districts. | | | |
| | | | |
| h | Primary Frontage | 30-foot minimum or behind building (whichever is less restrictive) | |
| i | Secondary Frontage | 8-foot minimum, landscaping setback along the entire parking frontage. | |
| j | Side Lot Line ⁽²⁾ | 0-foot minimum | |
| k | Rear Lot Line ⁽²⁾ | 0-foot minimum | |
| | | ⁽²⁾ Requirements per Section 1307.F.2.a when adjacent to single-family residential districts and historic properties or districts. | |
| ACCESSORY BUILDING SETBACKS | | LOT REQUIREMENTS | |
| e | Secondary Frontage | 8-foot minimum | Lot Coverage* 70% max. |
| f | Side Lot Line | 0-foot minimum | Primary Building Frontage 60% minimum |
| g | Rear Lot Line | 3-foot minimum | Secondary Building Frontage n/a |

TABLE 1303.2 TRANSECT T4

BUILDING FRONTAGE

FRONTAGE TYPES ALLOWED

| | |
|--------------------|--|
| Primary Frontage | Porch, patio, stoop, forecourt or alternative frontages as per Section 1305.B.1.c. |
| Secondary Frontage | Porch, patio, stoop, forecourt or alternative frontages as per Section 1305.B.1.c. |
| Entry Requirements | Building entries are optional along secondary frontages |

MINIMUM GLAZING ON BUILDING FRONTAGES FACING STREET RIGHT-OF-WAY.

| | | |
|--------------|------------------------|--|
| Ground Floor | 25% | Exceptions identified in Section 1312. |
| Second Floor | 25%, 10% East and West | |
| Upper Floors | n/a | |

BUILDING HEIGHT AND STEPBACKS

| BUILDING HEIGHT | | BUILDING STEPBACKS |
|-----------------------|--|---|
| a Main Building | T4:2 30-foot maximum T4:3 40-foot maximum SFA: 48-foot maximum | Required for SFA as per 1303.A.1 and 2. |
| b Accessory Buildings | T4:2 30-foot maximum T4:3: 40-foot maximum 30-foot maximum when adjacent to single family residential districts or Historic Preservation districts or properties | |

* Lot coverage maximum may be modified for SFA development option

TABLE 1303.2 TRANSECT T5

BUILDING LOT STANDARDS

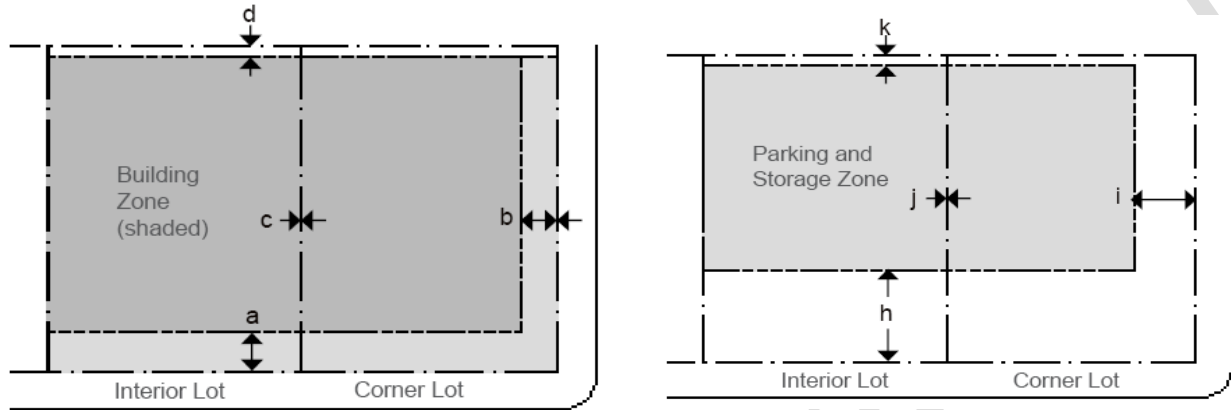

| MAIN BUILDING SETBACKS | | | PARKING SETBACKS | | |
|---|------------------------------|-----------------|--|------------------------------|---|
| a | Primary Frontage | 12-foot maximum | h | Primary Frontage | 30-foot minimum or behind building. |
| b | Secondary Frontage | 10-foot maximum | i | Secondary Frontage | 20-foot minimum, 10-foot landscape setback from street right-of-way |
| c | Side Lot Line ⁽¹⁾ | 0-foot minimum | j | Side Lot Line ⁽²⁾ | 0-foot minimum |
| d | Rear Lot Line ⁽¹⁾ | 0-foot minimum | k | Rear Lot Line ⁽²⁾ | 0-foot minimum |
| ⁽¹⁾ Setbacks requirements as per Section 1303.A.3 when adjacent to single-family residential districts and historic properties or districts. | | | ⁽²⁾ Requirements per Section 1307.F.2. when adjacent to single-family residential districts and historic properties or districts. | | |
| ACCESSORY BUILDING SETBACKS | | | LOT REQUIREMENTS | | |
| <i>Accessory buildings are subject to the setback standards of main buildings.</i> | | | Lot Coverage* | 80% maximum | |
| | | | Primary Building Frontage | 70% minimum | |
| | | | Secondary Building Frontage | 50% minimum | |

BUILDING FRONTAGE

FRONTAGE TYPES ALLOWED

TABLE 1303.2

TRANSECT T5

| | |
|--------------------------------|--|
| Primary or Light Rail Frontage | All frontages or alternative frontages as per Section 1305.B.1.c. |
| Secondary Frontage | All frontages or alternative frontages as per Section 1305.B.1.c. |
| Entry Requirements | Common Entry: Minimum one per 50-feet of primary building frontage and one per 80-feet of secondary frontage. Other frontages as per Table 1305.1. |

MINIMUM GLAZING. Minimum glazing shall apply to commercial frontages only. For residential products T4 glazing standards shall apply.

| | |
|--------------|---|
| Ground Floor | 75%. Modifications as per Table 1305.1 and Sections 1305.B.2. and 1312.A. Exceptions for Transit Gateway character area per Section 1312. |
| Second Floor | 45%, 25% East and West. |
| Upper Floors | 25%, 15% East and West. |

BUILDING HEIGHT AND STEPBACKS

| BUILDING HEIGHT | | BUILDING STEPBACKS |
|--------------------|-------------------------------|--|
| T5:2 | 30-foot maximum | |
| T5:3 | 48-foot maximum | Stepbacks required per Section 1303.A.4. |
| T5:5 | 56-foot maximum | Stepbacks required per Section 1303.A.4. |
| T5:6 | 80-foot maximum | Stepbacks required per Section 1303.A.4. |
| T5:7 | 100-foot maximum | At 48-foot of height Minimum 20-foot stepback adjacent to single-family residential districts or HP district or properties. |
| Parking structures | Cannot exceed building height | Minimum 20-foot stepback adjacent to single-family residential districts or HP district or properties if over 40-feet. |

- * a. Lot coverage maximum may be modified for SFA development option
- b. Lot coverage maximum may vary depending on setback requirements when adjacent to existing single-family residential districts and Historic Preservation properties or districts.

TABLE 1303.2 TRANSECT T6

BUILDING LOT STANDARDS

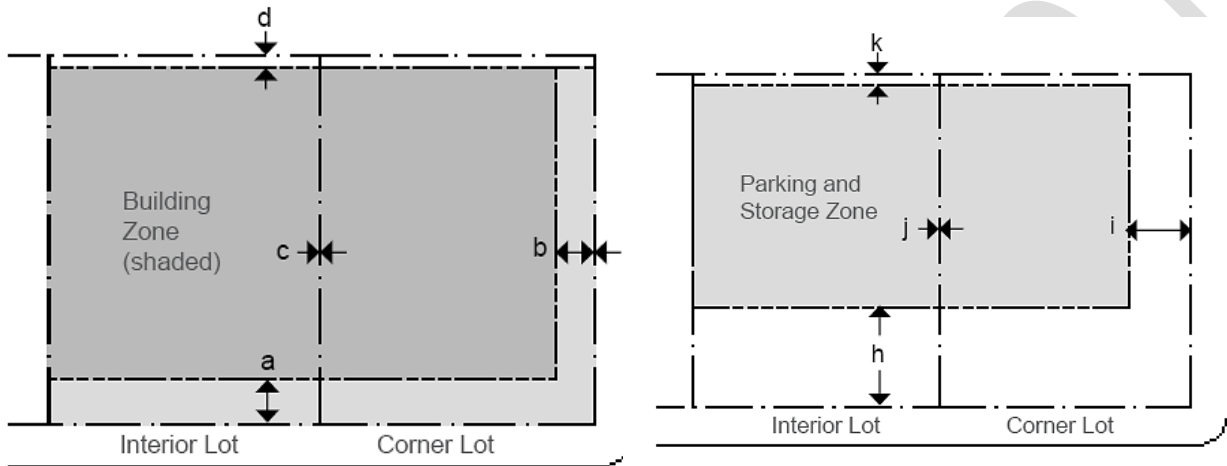

| MAIN BUILDING SETBACKS | | | PARKING SETBACKS | | |
|---|--------------------------------|-----------------|--|------------------------------|------------------------------------|
| a | Primary or Light Rail Frontage | 12-foot maximum | h | Primary Frontage | 24-foot minimum or behind building |
| b | Secondary Frontage | 10-foot maximum | i | Secondary Frontage | 20-foot minimum |
| c | Side Lot Line ⁽¹⁾ | 0-foot minimum | j | Side Lot Line ⁽²⁾ | 0-foot minimum |
| d | Rear Lot Line ⁽¹⁾ | 0-foot minimum | k | Rear Lot Line ⁽²⁾ | 0-foot minimum |
| ⁽¹⁾ Setbacks requirements as per Section 1303.A.3 when adjacent to single-family residential districts and historic properties or districts. | | | ⁽²⁾ Requirements per Section 1307.F.2. when adjacent to single-family residential districts and historic properties or districts. | | |
| ACCESSORY BUILDING SETBACKS | | | LOT REQUIREMENTS | | |
| <i>Accessory buildings are subject to the setback standards of main buildings.</i> | | | Lot Coverage* | 90% maximum | |
| | | | Primary Building Frontage | 80% minimum | |
| | | | Secondary Building Frontage | 70% minimum | |

BUILDING FRONTAGE TYPES

TABLE 1303.2 TRANSECT T6

FRONTAGE TYPES ALLOWED

| | |
|--------------------------------|---|
| Primary or Light Rail Frontage | Common entry, storefront, arcade, gallery or alternative frontages as per Section 1305.B.1.c. |
| Secondary Frontage | Common entry, storefront, arcade, gallery or alternative frontages as per Section 1305.B.1.c. |
| Entry Requirements | One per 50-feet of primary building frontage and one per 80-feet of secondary frontage |

MINIMUM GLAZING. Minimum glazing shall apply to commercial frontages only. For residential products T4 glazing standards shall apply

| | |
|--------------|---|
| Ground Floor | 75%. Modifications as per Table 1305.1 and Sections 1305.B.2. and 1312.A. Exceptions for Transit Gateway character area per Section 1312. |
| Second Floor | 45%, 25% East and West |
| Upper Floors | 25%, 15% East and West |

- * a. Lot coverage maximum may be modified for SFA development option
- b. Lot coverage maximum may vary depending on setback requirements when adjacent to existing single-family residential districts and Historic Preservation properties or districts.

BUILDING HEIGHT AND STEPBACKS

| BUILDING HEIGHT | | | BUILDING STEPBACKS | |
|-----------------|-------------------|--|-----------------------|---|
| T6:7 | 100-foot maximum | | At 48-foot of height | Minimum 20-foot stepback adjacent to single-family or HP district/neighborhood |
| T6:15 | 180-foot maximum- | | At 48-foot of height | Minimum 20-foot stepback adjacent to single-family or HP district/neighborhood. |
| T6:22 | 250-foot maximum | | At 48 ft. of height | Minimum 30-foot stepback adjacent to single-family or HP district/neighborhood. |
| | | | At 120 feet of height | Minimum 20-foot stepback adjacent to single-family or HP district/neighborhood. |

| | | | |
|-------------------|-------------------------------|-----------|--|
| Parking structure | Cannot exceed building height | At 48 ft. | Minimum 20-foot setback if no liner building |
|-------------------|-------------------------------|-----------|--|

| TABLE 1303.2 | TRANSECT T6 HEIGHT WAIVER - T6:HWR |
|--|------------------------------------|
| <p>Sites with existing height waiver entitlements shall comply with stipulations and standards of the zoning case that approved the height entitlement prior to adoption of the Walkable Urban Code.</p> <p>New development plans for existing and new height waiver entitlement properties shall demonstrate conformance to the T6 Transect and in general conformance with Conceptual Master Plans within TOD Policy Plans. Deviation from the WU Code and District Plans shall be approved in accordance with Section 1313.</p> | |

DRAFT - 02-23-2015

C. SPECIAL DISTRICT TRANSECT - SD

Applicability. This Section includes standards affecting sites with specific plans, or other existing entitlements other than just height. Special District (SD), as per 1302.A.1.i.

1. UPTOWN DISTRICT

a. Phoenix Indian School Special District.

- (1) All development within the boundaries of the SD Transect shall conform to the standards of the Phoenix Indian School Specific Plan.
- (2) Any alterations to the existing stipulations and standards may require an amendment to the specific plans or amendment of the applicable zoning case stipulation.
- (3) New development plans shall demonstrate conformance to the WU Code and in general conformance with the Conceptual Master Plan within the Uptown TOD Policy Plan. Deviation from the District Plans shall be approved in accordance with Section 1313.

2. MIDTOWN DISTRICT

RESERVED

3. SOLANO DISTRICT

RESERVED

4. EASTLAKE-GARFIELD DISTRICT

RESERVED

5. GATEWAY DISTRICT

RESERVED

SECTION 1304 GENERAL SITE DEVELOPMENT STANDARDS

A. Block Size. For all new development, the maximum continuous length of blocks, measured along the centerline of the street, and between intersecting street centerlines shall not exceed 600-feet unless conditions of Section 1304.G.2 are met.

B. Building Placement

1. Buildings must be set back from lot boundaries as specified in Tables 1303.1 and 1303.2, and according to the following:
 - a. Frontage setbacks may be expanded or reduced by as much as 20 percent in order to match adjacent frontage setbacks.
 - b. For corner lots, see Section 30-13 of the City Code (G-76).
 - c. Planning and Development Department staff have the authority to modify the setback measurements identified in each transect district up to 25 percent to accommodate existing conditions or a design solution consistent with a pedestrian environment.
 - d. Where public utility easements conflict with required setbacks or build to dimensions, the measurement can be taken from the back of the easement.

C. Building Design

1. All sides of a building should exhibit design continuity and contain multiple exterior accent materials that exhibit quality and durability.
2. Visible side and rear building façades should have a level of trim and finish compatible with the front façade.
3. All sides of a structure should exhibit design continuity and contain multiple exterior accent materials that exhibit quality and durability.
4. Monotonous building elevations should be avoided, building accents should be expressed through differing materials or architectural detailing rather than applied finishes such as paint, graphics, or forms of plastic or metal panels.

5. Multiple buildings on the same site should borrow and incorporate (not duplicate) architectural styles, materials, forms, features, colors and compatible elements from the same site. These should include: continuation of distinctive rooflines, covered walkway alignments, consistent detailing of finish, accent features on all visible sides of structures, compatible shapes, material, wall and landscaping treatment.
6. The orientation of buildings, windows and balcony features should not significantly reduce or infringe on the existing privacy of adjacent Single-Family or Multifamily residential districts.

D. Lighting Requirements. Lighting standards from 507 TAB A.II.8. of the Zoning Ordinance and Section 23-100 of the City Code shall apply.

E. Canal Banks. Standards from 507 TAB A.II.2. of the Zoning Ordinance shall apply for projects adjacent to the Grand Canal.

1. Height development may be measured from the canal bank grade.

F. Building and Shade

1. A minimum of 75-percent of the sidewalk or pedestrian way should be shaded.
 - a. Shade calculations shall be based on the summer solstice at 12:00 p.m.
 - b. Shade cast from a building may count towards shade calculations.
2. Developments should include shading along its entire right-of-way frontage, excluding driveways, loading, and service berths.
3. Required shade can be accomplished by one or a combination of the following methods:
 - a. Sidewalk landscape requirements as per Section 1309.
 - b. Landscape and shade trees within the front setback, as per Section 1309.B.1.
 - c. Structural shade elements, trellises, or covered walkways attached to the primary building. Depth should be a minimum of

6-feet measured from any point of ground floor façade to the exterior column or vertical plane of the overhang. The maximum head clearance should not exceed 20-feet, measured from finish grade.

- d. Detached shade structures should be a minimum of 6-feet in depth and 16-feet in height and should incorporate architectural elements and design of the primary structure. Footers should be a minimum six-feet from public utilities, measured from the outside of the utility.
- e. Structures within six-feet of a public utility (water/sewer line) should have a minimum 16-foot clear height and be removable.
- f. Any projections into public right-of-way should be permitted only upon issuance of an encroachment permit as administered by the City of Phoenix, and if applicable, approval from affected public utility companies.

- 4. Private and or public open space shade requirements per Section 1310.

G. Large Scale Development Requirements.

- 1. Large developments are intended to create and reinforce pedestrian urban environments with a mix of housing, civic, retail and service choices within a compact, walkable, and transit-oriented environment, in order to provide greater integration of public and private improvements and infrastructure, and to enable thoroughfare connectivity.
- 2. Block length exceeding the maximum block length permitted under Section 1304.A, or assemblages over five-acres in size are permitted under the following conditions:
 - a. Master Development Plans must be provided to the Planning and Development Department.
 - b. Plans should include a mix of housing and mixed use types.
 - c. At least five percent of its aggregated lot area shall be provided as an open space available to the public. Developer shall be responsible for the construction and maintenance of the open space available to the public.

- d. The plan shall include improvements to thoroughfares and pedestrian access.
 - (1) Thoroughfares may include existing alleyways and cross-block access within the development;
 - (2) Pedestrian ways/paseo for circulation, access and connectivity should be provided at:
 - (a) Any point along a frontage that is more than 300-feet from a thoroughfare intersection or existing pedestrian way;
 - (b) Cross-block access when the lot is a through lot;
 - (c) Lots other than through lots should provide a pedestrian paseo up to the mid-block shared lot line or alley. Where existing pedestrian access exist on adjacent lots, they should be completed.

H. Pedestrian Accessway Guidelines

1. Pedestrian ways, including paseos, should meet the following minimum standards:
 - a. Pedestrian ways should be open for public access from 7 A.M. to 10 P.M., or during the public hours of any off-street parking areas to which they provide access, whichever is longer.
 - b. Pedestrian ways should be a minimum of 10-feet in width or a minimum of six-feet in width when combined with a thoroughfare, or when provided as improved pedestrian alley access.
 - c. Pedestrian ways don't have to be straight, but should be entirely visible from one or both of the thoroughfares or private accessways which they connect.
 - d. All ADA guidelines shall apply.
 - e. Lighting should be provided to ensure safety and security. The following lighting treatment should be provided within pedestrian ways and Paseos:
 - (1) 15-foot maximum height of lighting fixtures.

- (2) A minimum of 1-foot candle illumination should be maintained throughout the Paseo.
 - (3) Uniform lighting should be placed along entire Paseo to avoid bright high glare areas and low visibility dark areas.
- f. One of the following elements should be provided at each street entrance to the Paseo:
- (1) Bollard path light.
 - (2) Public art.
 - (3) Decorative directional signage
 - (4) Building design elements that emphasize the Paseo entrance.

I. Access/Circulation

1. All requirements of Section 507 TAB.A.II.A.6.3. shall apply except Section 507 TAB.A.II.A.6.3.1.
2. Private driveways and off-street parking should be accessed from alleys as much as possible.
3. The entrances to alleys should be directed away from the primary frontages of T5 and T6 lots, except where it is unavoidable that they cross such a frontage.
4. Vehicular maneuvering in an alley is allowed if no Single-Family or Historic Preservation zoned district or Historic neighborhood is adjacent to the alley.

- J.** Alternative paving materials such as permeable pavers, porous concrete or similar materials should be used for on-site hardscaping to reduce urban heat island effect, and to allow natural drainage and filtration.

SECTION 1305 FRONTAGE STANDARDS

- A. Applicability.** Standards and Frontage Types in this section regulate the area between the property line and the front façade of a building in order support an urban, pedestrian and transit-oriented environment within the boundaries of the WU Code.

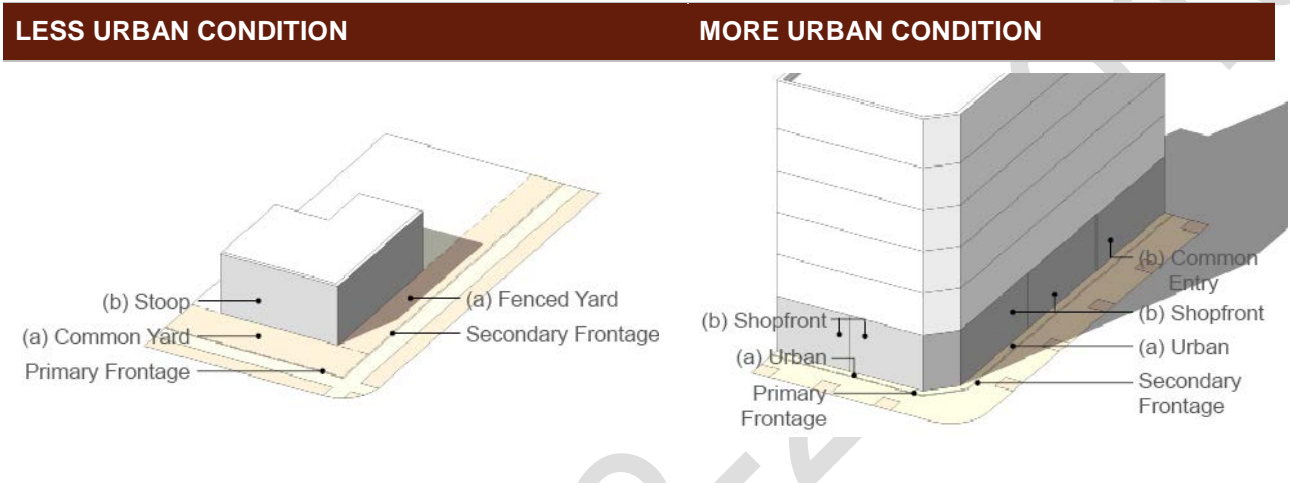

B. Frontage Types.

1. Frontage types are limited to Table 1305.1, with the following exceptions.
 - a. Building façades may include multiple frontage types along their length.
 - b. Frontage types may be different at primary and secondary frontages.
 - c. Planning and Development Department staff may consider a frontage design alternative when the design meets the intent of pedestrian and transit-oriented frontages and façades. Appeals beyond staff level may be filed by applicants to the Design Review Committee per Section 1313.
2. Building Façades.
 - a. Building façades shall be designed to provide a sense of human scale at the ground level by providing a clear architectural distinction between the ground floor and all additional stories.

- (1) All structures, except where residential uses are on the ground floor, should utilize clear windows. A clear window is a window that will allow a minimum of 75 percent of the visible light (as specified by the manufacturer) to be visible on either side of the window.
- (2) Ground floor blank walls visible from the public sidewalk should not exceed 20 linear feet without being interrupted by a window, or variation in building treatment or design.
- (3) Façade treatments should be provided when the minimum glazing cannot be achieved, or when the blank wall façade exceeds a continuous 20 linear feet. Treatments can be achieved through a combination of artwork, interactive displays, architectural features, landscape and trellises, with a minimum size of 30 square feet per 20 linear feet of blank wall. Shadow boxes are permitted for art houses and cinemas.
- (4) Mirrored and reflective glass are prohibited.
- (5) Religious assembly building façades are exempt from the minimum glazing requirement.
- (6) Grocery store frontages shall provide a minimum of 60 percent glazing along on the ground floor of a primary frontage or light rail corridor. 50 percent minimum glazing required on the ground floor of secondary frontages.

3. Building Entrances.

- a. All pedestrian entrances should be defined by the use of distinctive materials and architectural elements.
- b. The primary building entry should be located within the primary frontage. Interior spaces of each building should be as directly accessible as possible from frontages.
- c. Building frontages on arterials should be oriented to the arterial frontage. The preferred arrangement is to front façades directly adjacent to the sidewalk.

4. Projections in the Right of Way as follows:

- a. Where public utility easements, water/sewer lines or irregular lot lines cause conflicts with specific Frontage Types and Frontage Setback Types, Planning and Development staff may modify numeric setback and landscape requirements up to 25 percent and allow build to dimensions to be taken from the back of the public utility easement.
 - b. A minimum 16-foot height clearance needed from public water/sewer lines, unless shade is retractable or an encroachment permit is secured as administered by the City of Phoenix.
5. Projections into frontage setbacks:
- a. Underground parking within frontage setbacks is not considered a projection, provided that the underground structure is not visible from the sidewalk or frontage.
 - b. Maximum projection by porches, patios, balconies and port-cocheres into the required building setback on T3 and T4, not on arterial or light rail streets:
 - (1) Primary Frontage: 10-feet
 - (2) Secondary Frontage: 5-feet.
 - (3) Bay and bow windows may project into the frontage setbacks up to 3-feet.
 - c. Shading devices, attached or detached to façades may project into frontage setbacks as follows:
 - (1) In T3 and T4, may project into any required setback up to 10-feet.
 - (2) In T5 and T6, shading devices may project into any required setback up to the lot line, but not beyond the lot line unless an encroachment permit is obtained as administered by the City of Phoenix.
6. Corner Lots abutting an arterial street and along the light rail corridor should enhance the pedestrian and transit oriented environment through at least one of the following:

- a. Distinctive massing, angled or rounded building corners, courtyards and plazas;
- b. Architectural features, colors and materials, public art;
- c. Public entrances should be defined by the use of distinctive materials and colors, and architectural elements;
- d. Primary entrances should be at the corner or facing both streets.



| TABLE 1305.1 FRONTAGE TYPES | |
|---|--|
| FRONTAGE: PORCH | |
| Entry Grade | Maximum of five feet above adjacent grade. |
| Requirements | <ul style="list-style-type: none"> (a) Placement: Porch is required at the primary building entry. (b) A primary building entrance per unit is required when fronting a street. (c) Minimum depth: 6-feet (d) Minimum width: 50 percent of the façade. (e) Porches and related structures may project into frontage setbacks as per Section 1305.B.5. |
|  | |
| FRONTAGE: STOOP AND DOOR WELL | |
| Entry Grade | 60-inch maximum elevation above or below sidewalk grade. Maximum elevation may be increased if frontage designs incorporate patios and as access to second story. |
| Requirements | <ul style="list-style-type: none"> (a) A stoop with a primary building entrance per unit is required when fronting a street. (b) Minimum dimension: 6-feet (c) Minimum area: 36 square feet (d) <i>Stoops</i> and related structures may project into <i>frontage</i> setbacks no more than 30% of their depth in <i>T3</i> and 100% in <i>T4</i> and <i>T5</i>. |
|  | |

TABLE 1305.1 FRONTAGE TYPES

FRONTAGE: PATIO

| | | |
|---------------------|--|---|
| Entry Grade | 36-inch maximum from sidewalk grade |  |
| Requirements | <ul style="list-style-type: none"> (a) Patio is required at the main building entrance and a primary entrance shall be provided along each frontage. (b) Patios may encroach no more than 6-feet into frontage setbacks. (c) Minimum depth of 8-feet (d) Minimum area: 64 square feet. (e) Patio should be enclosed on each side. Fencing requirements as per Section 1305.C. (f) The area between the property line and main façade of the building which is not improved with permanent hardscape shall be planted with live vegetation ground coverage and shrubs excluding hardscape for pedestrian amenities. | |

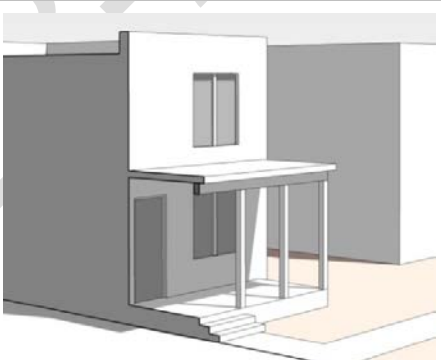
COMMON ENTRY

| | | |
|---------------------|--|---|
| Entry Grade | Up to 60-inch maximum from sidewalk grade |  |
| Requirements | <ul style="list-style-type: none"> (a) A single collective entry to a multi-tenant lobby is required at the primary building entrance. (b) If the frontage includes a stoop entrance: Stoop minimum dimension: 6-feet Minimum area: 36 square feet (c) <i>Stoops</i> and related structures may project into <i>frontage</i> setbacks no more than 30% of their depth in <i>T3</i> and 100% in <i>T4</i> and <i>T5</i>. (d) Canopies and awnings are permitted to project into frontage setbacks up to 100% of their depth | |

TABLE 1305.1 FRONTAGE TYPES

STOREFRONT

| | | |
|------------------------------|--|--|
| Entry Grade | At sidewalk grade |  |
| Requirements | <p>(a) Each ground floor storefront should provide a primary entrance that directly connects to the street.</p> <p>(b) Display windows may project into <i>frontage</i> setbacks no more than 5-feet.</p> <p>(c) Ground Floor Glazing: Minimum of 75 percent of the storefront area along a primary ground floor frontage. Minimum of 50 percent on secondary ground floor frontage.</p> | |
| Storefront Guidelines | <p>(d) Building entries may be recessed from the façade up to 8-feet in depth.</p> <p>(e) Awnings may project into frontage setbacks up to 100% of their depth.</p> <p>(f) Awnings may encroach into the public right-of-way, covering the sidewalk, with an appropriate permit. A minimum 16-foot height clearance needed from public water/sewer lines.</p> | |

GALLERY

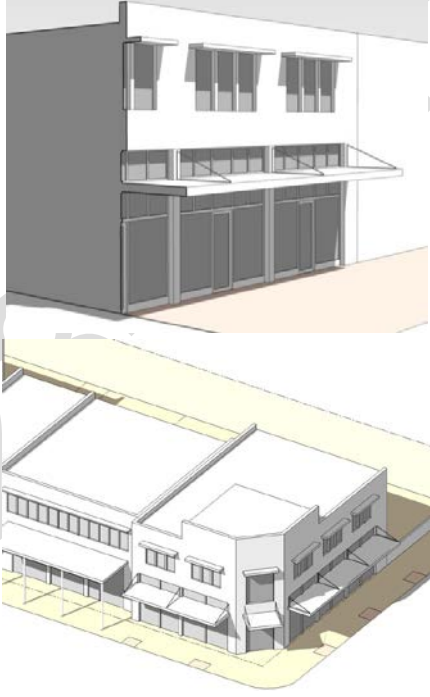
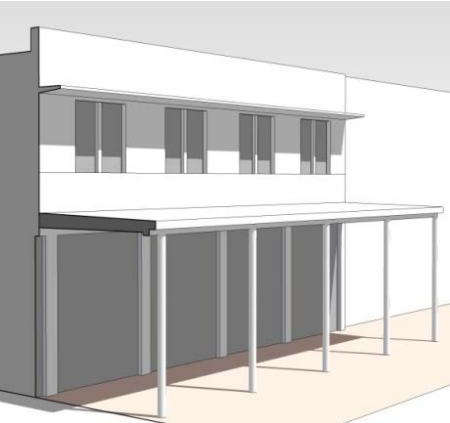
| | | |
|---------------------|---|--|
| Entry Grade | At sidewalk grade |  |
| Requirements | <p>(a) A gallery is required along a minimum of 80% of the frontage.</p> <p>(b) Minimum depth: 10-feet</p> <p>(c) Minimum height clearance: 10-feet. Minimum 16-foot clearance needed from public water/sewer lines.</p> <p>(d) Ground Floor Glazing: Minimum of 75 percent of the storefront along a primary ground floor frontage. Minimum of 50 percent on secondary ground floor frontage.</p> | |

| TABLE 1305.1 FRONTAGE TYPES | |
|------------------------------------|--|
| Guidelines | <ul style="list-style-type: none"> (e) Galleries should project into frontage setbacks for their full depth. (f) Each ground floor commercial suite adjacent to a street shall provide a primary entrance on the street side that directly connects to the street, unless a corner entrance is provided. |
| ARCADE | |
| Entry Grade | At sidewalk grade |
| Requirements | <ul style="list-style-type: none"> (a) An arcade is required along a minimum of 80 percent of the frontage. (b) Minimum depth: 10-feet (c) Minimum height clearance: 10-feet. Minimum 16-foot clearance needed from public water/sewer lines. (d) Ground Floor Glazing: Minimum of 75 percent of the storefront along a primary ground floor frontage. Minimum of 50 percent on secondary ground floor frontage. |
| Guidelines | (e) Arcades should project into frontage setbacks for their full depth. |
| FORECOURT | |
| Area | <ul style="list-style-type: none"> (a) Forecourts are allowed to setback from maximum setback standards in T5 and T6. (b) Forecourt areas should be a minimum of 500 square feet with a minimum dimension of 20-feet parallel to the street. (c) Shading: A maximum height of 40-inch open view fence permitted at outdoor seating areas and at building setback lines. |

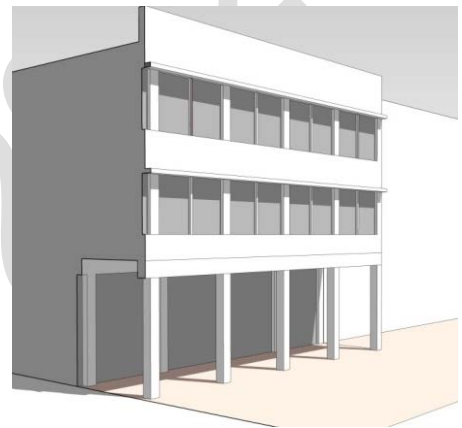

TABLE 1305.1 FRONTAGE TYPES

| | |
|-------------------------------|--|
| Shading | (a) A minimum of 50 percent of forecourt area shall be shaded, of which 50 percent of the shade should be provided by trees or trellised vines. (b) Shading should be provided for adjacent sidewalk as per Section 1304.G.1. (c) Tree requirements as per Section 1309, Table 1309.1 and 2. |
| Activation and Glazing | (a) Non-residential forecourts: Must be lined with uses on ground floor frontages facing forecourts. 75 percent minimum glazing requirement for frontages within the forecourt. (b) Glazing at street frontage: Minimum of 75 percent of the storefront area along a primary ground floor frontage and 50 percent on secondary ground floor frontage. |

C. Fence Requirements

1. T3 and T4
 - a. Primary frontages: 40-inches maximum height.
 - b. Secondary frontages: 72-inches maximum height. For SFA development: 48-inches maximum height solid fence. Above 48-inches to 72-inches allowed only as a 70-percent open view fence, unless screening above grade utilities or trash enclosures.
2. T5 and T6:
 - a. Primary frontages: 40-inches maximum height.
 - b. Secondary frontages: 48-inches maximum height solid fence. Above 48-inches to 72-inches allowed only as a 70 percent open view fence, unless screening above grade utilities or trash enclosures.
3. For properties located within a Historic Preservation (HP) Overlay District, fences or freestanding walls in the front yard, meaning the space between the structure and the street right-of-way line, may not exceed a maximum height of three-feet, and are conditioned upon obtaining a certificate of appropriateness or no effect in accordance with Section 812 of the Phoenix Zoning Ordinance. This height limitation extends to a point three-feet beyond the front corner(s) of the primary structure.

SECTION 1306 LAND USE MATRIX

A. Applicability.

1. The Land Use Matrix in Table 1306.1 shall apply to all existing land uses within the WU Code boundaries.

B. Use Regulations.

1. Any use not specifically listed in the Land Use Matrix shall not be permitted with the exception of the following:
 - a. All Residential Uses south of the Light Rail Corridor in the Gateway and Eastlake-Garfield Character Areas require a use permit.
 - b. General Commercial and Industrial Uses. Allowed only within the Gateway Transit Gateway Character Area as per Section 1312.A.
2. All uses listed will be permitted (P), permitted with conditions (PC), permitted with the approval of a special permit (SP), permitted with the approval of a use permit (UP) or not permitted (NP).
3. When a use permit is required, it shall be obtained in accordance with the standards and procedures of Section 307.
4. Land Use Conditions shall apply to uses that are specified as PC.

TABLE 1306.1. LAND USE MATRIX

| CATEGORY: RESIDENTIAL USES | T3 | T4 | T5:2 | T5:3 | T5:5 | T5:6 | T5:7 | T6:7 T6:15 | T6:22 T6: HWR |
|--|-----------|-----------|-------------|-------------|-------------|-------------|-------------|-----------------------|------------------------------|
| Dwelling, Multifamily | NP | P | P | P | P | P | P | P | P |
| Dwelling, Single-Family, detached | P | P | NP | NP | NP | NP | NP | NP | NP |
| Dwelling, Single-Family and Duplex, attached | P | P | P | P | P | P | P | P | P |
| Live-Work | P | P | P | P | P | P | P | P | P |
| Assisted Living Home 1-10 residents | NP | P | P | P | P | P | P | P | P |
| Assisted Living Home 11+ residents | NP | UP | UP | P | P | P | P | P | P |

TABLE 1306.1. LAND USE MATRIX

| CATEGORY: RESIDENTIAL USES | T3 | T4 | T5:2 | T5:3 | T5:5 | T5:6 | T5:7 | T6:7 T6:15 | T6:22 T6: HWR |
|---|-----------|-----------|-------------|-------------|-------------|-------------|-------------|-----------------------|------------------------------|
| Dependent Care Facility 1-6 residents: | PC | PC | PC | P | P | P | NP | NP | NP |
| Dependent Care Facility 7-12 residents: | NP | UP | UP | P | P | P | NP | NP | NP |
| Group Home | UP | UP | UP | UP | P | P | NP | NP | NP |
| Group Home for the Handicapped 5-10 residents (not including staff) 11+ residents | PC NP | PC PC | PC PC | PC PC | PC PC | PC PC | NP NP | NP NP | NP NP |

C. Residential Uses, Land Use Conditions.

1. Assisted Living

- a. Such home shall be licensed by the State of Arizona

2. Dependent Care Facility

- a. One to six residents: Standards as per Section 608.D.1. Use Permit required for 7 to 12 residents.

3. Group homes for the handicapped

- a. No such home is located on a lot with a property line within one thousand three hundred twenty feet, measured in a straight line in any direction, of the lot line of another such group home.
- b. Such home is registered with, and administratively approved by, the Zoning Administrator.
- c. The subject property must be at least 1,320 feet away from another registered Handicapped Group home that has 6-10 residents
- d. Notwithstanding the foregoing, group homes shall not house any person whose tenancy would constitute a direct threat to the health

or safety of other individuals or would result in substantial physical damage to the property of others.

| CATEGORY: ASSEMBLY USES | T3 | T4 | T5:2 | T5:3 | T5:5 | T5:6 | T5:7 | T6:7 T6:15 | T6:22 T6: HWR |
|---|-----------|-----------|-------------|-------------|-------------|-------------|-------------|-----------------------|------------------------------|
| Assembly, Entertainment | NP | NP | PC | PC | PC | PC | PC | PC | PC |
| Assembly, General | NP | NP | PC | PC | PC | PC | PC | PC | PC |
| Assembly, Places of Worship | PC | PC | PC | PC | PC | PC | PC | PC | PC |
| Commercial Recreation | NP | NP | P | P | P | P | P | P | P |
| Day Care, Nursery School | PC | PC | P | P | P | P | P | P | P |
| Schools, Mentally or Physically Handicapped | NP | UP | UP | UP | UP | UP | UP | UP | UP |
| School, Public and Private | P | P | P | P | P | P | P | P | P |
| School, Private | P | P | P | P | P | P | P | P | P |
| Theater | NP | NP | P | P | P | P | P | P | P |

D. Assembly Uses, Land Use Conditions.

1. Assembly, Entertainment

- a. Outdoor event or performances are open to the public.
- b. The outdoor event or performance must be presented by an existing business on the property.
- c. The business' regularly stocked items may be displayed outdoors and be available for purchase during the event or performance. Payment for all items shall occur indoors. No other items may be displayed for sale outdoors during the event or performance.
- d. Outdoor entertainment may not start before 7:00 a.m. and must terminate at 11:00 p.m., Monday through Saturday, and 10:00 p.m. on Sunday, except when additional hours are allowed by a use permit.
- e. In T3 the use is limited to Fridays, Saturdays and Sundays only.

f. No amplified music or loudspeakers may be used outside after 8:00 p.m. on Monday-Thursday and Sundays, and after 10:00 p.m. on Fridays and Saturdays, unless a use permit is obtained.

2. Assembly, General

- a. Any assembly hall or banquet hall of less than 25,000 square feet in gross area, shall be permitted only upon securing a use permit.
- b. Outdoor uses shall be permitted only upon securing a use permit.

3. Assembly, Places of Worship

- a. As per Section 608.E.

4. Day Care/Nursery School

- a. Outdoor uses or activities must be screened by a minimum 6-foot high solid decorative fence or wall.

| TABLE 1306.1. LAND USE MATRIX | | | | | | | | | |
|--|-----------|-----------|-------------|-------------|-------------|-------------|-------------|-----------------------|------------------------------|
| CATEGORY: ANIMAL CARE | T3 | T4 | T5:2 | T5:3 | T5:5 | T5:6 | T5:7 | T6:7 T6:15 | T6:22 T6: HWR |
| Pet Care Facility, Indoor Only | NP | NP | P | P | P | P | P | NP | NP |
| Pet Day Care Facility, Outdoor Accessory Uses. As per Section 622.D.126 | NP | NP | PC | PC | PC | PC | NP | NP | NP |
| Laboratory, Research | NP | NP | P | P | P | P | P | P | P |
| Veterinary Office , Indoor As per Section 622.D.171 | NP | NP | PC | PC | PC | PC | PC | PC | PC |
| Veterinary Office, Outdoor Accessory Uses . As per Section 622.D.172 | NP | NP | UP | UP | UP | UP | UP | UP | UP |

| TABLE 1306.1. LAND USE MATRIX |
|--------------------------------------|
|--------------------------------------|

| CATEGORY: GENERAL RETAIL | T3 | T4 | T5:2 | T5:3 | T5:5 | T5:6 | T5:7 | T6:7 T6:15 | T6:22 T6: HWR |
|--|-----------|-----------|-------------|-------------|-------------|-------------|-------------|-----------------------|------------------------------|
| General Retail permitted, including all dining and drinking establishments, except with the following conditions: | | | | | | | | | |
| General Retail | NP | UP | P | P | P | P | P | P | P |
| Artist Studio/Gallery | NP | NP | P | P | P | P | P | P | P |
| Bakery | NP | NP | P | P | P | P | P | P | P |
| Garden Center, Plant Nursery | NP | NP | NP | P | P | P | P | P | P |
| Grocery Stores | NP | PC | PC | PC | PC | PC | PC | PC | PC |
| Guns, Retail Sales, and/or Repairs. As per Section 623.D.82 | NP | NP | UP | UP | UP | UP | UP | UP | UP |
| Liquor, Retail Sales | NP | NP | UP | UP | UP | UP | UP | UP | UP |
| Second Hand/Used Merchandise Sales | NP | NP | PC | PC | PC | PC | PC | PC | PC |
| Tobacco Oriented Retailers | NP | NP | PC | PC | PC | PC | PC | PC | PC |
| Dining and drinking establishments: Nothing in this section shall be construed to include an adult use. | | | | | | | | | |
| Bars, Lounges/Cocktail Lounges | NP | NP | UP | UP | UP | UP | UP | UP | UP |
| Micro-brewery/Winery | NP | NP | UP | UP | UP | UP | UP | UP | UP |
| Restaurants | NP | NP | P | P | P | P | P | P | P |

E. General Retail, Land Use Conditions.

1. Grocery Stores.

- a. Ground floor building footprint greater than 50,000 requires use permit.

2. Second Hand or Used Merchandise Sales, subject to the following conditions or limitations per Transit District Policy Plan:

- a. Midtown and Uptown:

- (1) No merchandise shall be received and/or processed for sale at another site;
 - (2) Use shall not exceed 2,500 square feet of building area.
 - b. Eastlake-Garfield, Gateway and Solano.
 - (1) Use shall not exceed 5,000 square feet of building area unless a use permit is obtained.
3. **Tobacco Oriented Retailers**, subject to the following limitations:
- a. Shall not be located within 500-feet of the same type use. This distance shall be measured from the property line of the parcel in which the use is conducted to the nearest property line of the parcel of the same type of use.
 - b. Shall not be located within 500-feet of a public, private, or charter school providing primary or secondary education, a park or playground, or a licensed daycare facility. This distance shall be measured from the property line of the parcel in which the use is conducted to the nearest property line of the protected use.
4. **Micro Brewery**. The facility shall be licensed by the State as a producer, domestic microbrewery or domestic farm winery.

| CATEGORY: SERVICES | T3 | T4 | T5:2 | T5:3 | T5:5 | T5:6 | T5:7 | T6:7 T6:15 | T6:22 T6: HWR |
|---|-----------|-----------|-------------|-------------|-------------|-------------|-------------|-----------------------|------------------------------|
| Bed and Breakfast | NP | P | NP | NP | NP | NP | NP | NP | NP |
| Clinic, Medical or Dental | NP | NP | P | P | P | P | P | P | P |
| Business Services | NP | NP | P | P | P | P | P | P | P |
| Financial institutions | NP | NP | P | P | P | P | P | P | P |
| Home Occupation As per Section 608.E.3 | PC | PC | P | P | P | P | P | P | P |
| Hospital | NP | NP | NP | UP | P | P | P | P | P |
| Hotel | NP | UP | P | P | P | P | P | P | P |

| TABLE 1306.1. LAND USE MATRIX | | | | | | | | | |
|---|-----------|-----------|-------------|-------------|-------------|-------------|-------------|-----------------------|------------------------------|
| CATEGORY: SERVICES | T3 | T4 | T5:2 | T5:3 | T5:5 | T5:6 | T5:7 | T6:7 T6:15 | T6:22 T6: HWR |
| Laboratory, Medical, Dental or Clinical | NP | NP | P | P | P | P | P | P | P |
| Medical or Dental Office | NP | NP | P | P | P | P | P | P | P |
| Office, General | NP | NP | P | P | P | P | P | P | P |
| Office, Professional As per Section 618.D.13 | PC | PC | PC | PC | PC | PC | PC | PC | PC |
| Personal Services | NP | NP | P | P | P | P | P | P | P |
| Tattoo/Body-Piercing Studio | NP | NP | P | P | P | P | P | P | P |

| TABLE 1306.1. LAND USE MATRIX | | | | | | | | | |
|--|-----------|-----------|-------------|-------------|-------------|-------------|-------------|-----------------------|------------------------------|
| CATEGORY: LOCAL FOOD PRODUCTION | T3 | T4 | T5:2 | T5:3 | T5:5 | T5:6 | T5:7 | T6:7 T6:15 | T6:22 T6: HWR |
| Community Garden As per Section 608.F.3. | UP | UP | UP | UP | UP | UP | UP | UP | UP |
| Farmers Markets As per Section 608.F.4. | UP | UP | UP | UP | UP | UP | UP | UP | UP |

| TABLE 1306.1. LAND USE MATRIX | | | | | | | | | |
|---|-----------|-----------|-------------|-------------|-------------|-------------|-------------|-----------------------|------------------------------|
| CATEGORY: AUTOMOTIVE, COMMUNICATIONS AND UTILITIES | T3 | T4 | T5:2 | T5:3 | T5:5 | T5:6 | T5:7 | T6:7 T6:15 | T6:22 T6: HWR |
| Motor Vehicle Service Station, Fuel Sales | NP | NP | PC | PC | PC | PC | PC | PC | PC |
| Motor Vehicle Service and Repair, Minor | NP | NP | PC | PC | PC | PC | PC | PC | PC |
| Bus Terminal | NP | NP | NP | SP | SP | SP | SP | SP | SP |

| TABLE 1306.1. LAND USE MATRIX | | | | | | | | | |
|---|-----------|-----------|-------------|-------------|-------------|-------------|-------------|-----------------------|------------------------------|
| CATEGORY: AUTOMOTIVE, COMMUNICATIONS AND UTILITIES | T3 | T4 | T5:2 | T5:3 | T5:5 | T5:6 | T5:7 | T6:7 T6:15 | T6:22 T6: HWR |
| Wireless Communications As per Section 715. | NP | NP | PC | PC | PC | PC | PC | PC | PC |

F. Automotive, Communications and Utilities, Land Use Conditions

1. Motor Vehicle Service Station, Fuel Sales

- a. Shall not be located within one thousand three hundred twenty feet (1320') from a Light Rail station.
- b. Gasoline pumps must not be located between the main building and primary frontages.

2. Motor Vehicle Service and Repairs, Minor

- a. Shall not be located within one thousand three hundred twenty feet (1320') from a Light Rail station.
- b. Vehicle and parts storage must not be visible from frontages.
- c. Not permitted in the Transit Uptown or Midtown Character Areas.

| TABLE 1306.1. LAND USE MATRIX | | | | | | | | | |
|--|-----------|-----------|-------------|-------------|-------------|-------------|-------------|-----------------------|------------------------------|
| CATEGORY: ACCESSORY USES | T3 | T4 | T5:2 | T5:3 | T5:5 | T5:6 | T5:7 | T6:7 T6:15 | T6:22 T6: HWR |
| Accessory Dwelling Unit | P | P | P | P | P | P | P | P | P |
| Accessory Dwelling Unit – Guest | P | P | P | P | P | P | P | P | P |
| Accessory Structure | P | P | P | P | P | P | P | P | P |
| Compressed Natural Gas (CGN) Retail Sales | NP | NP | UP | UP | UP | UP | UP | UP | UP |
| Drive-Through | NP | NP | PC | PC | PC | PC | PC | PC | PC |

| TABLE 1306.1. LAND USE MATRIX | | | | | | | | | |
|---|-----------|-----------|-------------|-------------|-------------|-------------|-------------|-----------------------|------------------------------|
| CATEGORY: ACCESSORY USES | T3 | T4 | T5:2 | T5:3 | T5:5 | T5:6 | T5:7 | T6:7 T6:15 | T6:22 T6: HWR |
| Helistop/Heliport | NP | NP | NP | SP | SP | SP | SP | SP | SP |
| Home Occupation As per Section 608.E.3. | PC | PC | PC | PC | PC | PC | PC | PC | PC |
| Liquor Service | NP | NP | UP | UP | UP | UP | UP | UP | UP |
| Massage Therapy | NP | NP | PC | PC | PC | PC | PC | PC | PC |
| Motor Vehicle and Sales (new) and Leasing | NP | NP | NP | PC | PC | PC | PC | PC | PC |
| Motor Vehicle Washing | NP | NP | PC | PC | PC | PC | PC | PC | PC |
| Outdoor Cooking | NP | NP | UP | UP | UP | UP | UP | UP | UP |
| Outdoor Dining | NP | NP | PC | PC | PC | PC | PC | PC | PC |
| Outdoor Display/Sales | NP | NP | UP | UP | UP | UP | UP | UP | UP |
| Outdoor Entertainment | NP | NP | PC | PC | PC | PC | PC | PC | PC |
| Outdoor Liquor Service | NP | NP | UP | UP | UP | UP | UP | UP | UP |
| Outdoor Storage Permitted only as per Sections 1312.A and B. | NP | NP | NP | PC | PC | PC | NP | NP | NP |
| Patron Dancing | NP | NP | PC | PC | P | P | P | P | P |
| Pocket Shelter (accessory to Religious Assembly) | UP | UP | UP | UP | UP | UP | UP | UP | UP |

G. Accessory Uses, Land Use Conditions

1. Massage Therapy.

- a. Permitted as accessory use to beauty shops and tanning salons when performed by a licensed therapist.

2. Motor Vehicle Rental, Motor Vehicle Sales (new) and Leasing

- a. Allowed as accessory use only.

- b. Outdoor vehicle display and vehicle parking must not be located within frontages.
 - c. No on-site maintenance or washing allowed.
 - d. Maximum of 15 automobiles on site.
3. **Motor Vehicle Washing**
- a. Shall not be located within one thousand three hundred twenty feet (1320') from a Light Rail station.
 - b. Vehicular ingress and egress from carwashes must be onto internal circulation ways, not directly onto frontages. All outdoor activities, including hand drying and vacuuming should be located behind the structure and away from the right-of-way.
4. **Drive-Through.**
- a. Allowed as an accessory use only.
 - b. Drive-through and related queuing are not permitted between the principal building and frontages.

| TABLE 1306.1. LAND USE MATRIX | | | | | | | | | |
|---|-----------|-----------|-------------|-------------|-------------|-------------|-------------|-----------------------|------------------------------|
| CATEGORY: INTERIM USES | T3 | T4 | T5:2 | T5:3 | T5:5 | T5:6 | T5:7 | T6:7 T6:15 | T6:22 T6: HWR |
| Interim Vacant Land Uses | PC | PC | PC | PC | PC | PC | PC | PC | PC |
| Environmental Remediation Facility As per 608.F.2. | UP | UP | UP | UP | UP | UP | UP | UP | UP |
| Surface parking Lot | NP | NP | NP | UP | UP | UP | UP | UP | UP |
| Civic Event | NP | NP | P | P | P | P | P | P | P |
| (P) Permitted (PC) Permitted with Conditions (UP) Use Permit (SP) Special Permit (NP) Not Permitted | | | | | | | | | |

H. Interim Uses, Land Use Conditions

1. Interim Vacant Lot Activation

- a. Is allowed if the property is adjacent to an arterial street with light rail tracks and light rail transit stations. Design review of structures shall be done through an administrative temporary use permit (ATUP) to ensure compatibility and consistency with zoning ordinance design standards.
- b. Allowed with use permit if property outside the areas noted above but within the Transit District Policy Plans for Gateway, Eastlake-Garfield, Midtown, Uptown and Solano.

SECTION 1307 PARKING STANDARDS

A. Applicability. This Section includes parking and loading standards. The following standards shall apply unless modified by the Character Area (Section 1312).

1. Section 702.D is replaced by this Section.
2. Sections 702.C., 702.E.6, 702.E.7 and 702.E.8 remain applicable unless modified in Section 1307.
3. General Commercial (C-3) and Light Industrial (A-1) parking as per Section 1312.A. and B.

B. Required Vehicular Parking.

1. Vehicular parking must be provided for each use in accordance with Table 1307.1 and as follows:
 - a. Minimum required vehicular parking is the sum of parking required for each use within a lot.
 - b. Accessory dwellings in T3 and T4 require one parking space per lot.
 - c. Vehicular parking may be limited to a maximum number of spaces by parking districts where established.
 - d. Other uses not identified on Table 1307.1. shall follow Section 702 standards.
2. Underground parking and service spaces, located below the pre-development ground level, may occupy up to 100-percent of the lot area.

| TABLE 1307.1. MINIMUM REQUIRED VEHICULAR PARKING | | | | | | |
|--|---------------------------------|-----------|-----------|---------------------------------|---------------------------------|---------------------------------|
| USE | MEASURE | T3 | T4 | T5 1-5 Stories | T5 6-10 Stories | T6 |
| Residential, Single -Family | per unit | 2.0 | n/a | n/a | n/a | n/a |
| Residential: Single-Family Attached and Multifamily | As per Section 702. | | | | | |
| Assisted Living and Group Home | per bedroom | 1 | 0.75 | 0.75 | | 0.5 |
| General Retail Sales | 1 space per sf | n/a | n/a | 300 sf 375 sf ⁽¹⁾ | | 600 sf 800 sf ⁽¹⁾ |
| Dining and Drinking Establishments | 1 space per sf | n/a | n/a | 100 sf | 300 sf 375 sf ⁽¹⁾ | 600 sf 800 sf ⁽¹⁾ |
| Lodging | per room | n/a | 0.75 | 0.5 | | 0.5 |
| Office and Professional Uses | 1 space per sf | n/a | n/a | 300 sf 375 sf ⁽¹⁾ | | 500 sf 625 sf ⁽¹⁾ |
| Affordable Housing | per unit | 0.85 | 0.75 | 0.5 | | 0.5 |
| Adaptive Reuse All other criteria per Section 702.E.8. | 1 space per sf | n/a | n/a | 1/100 sf | n/a | n/a |
| Medical Offices: Doctors, Dentists, Clinics, Centers | 1 space per sf | n/a | n/a | 200 sf | | 250 sf |
| Fitness Center - Accessory to primary use for private residential or tenant use | None required | | | | | |
| Fitness Center, Commercial | Permitted as per Section 702.C. | | | | | |
| (1) Additional reduction when the off-street parking area is located within one thousand three hundred twenty feet (1,320') of a Light Rail Station when measured in a direct line from the building. The minimum required on-site vehicular parking is exclusively for the patrons of the subject parcel. | | | | | | |

C. Vehicular Parking Reductions

1. Special needs population. Additional reductions may be allowed as per Section 702.E.6.
2. Shared Parking.
 - a. The standard shared parking model developed and administered by the Planning and Development Department shall be used for shared parking reductions.
 - b. Shared Parking reductions available for the following:
 - (1) Multiple connected lots with a recorded, non-revocable share use parking agreement;
 - (2) Public or private parking facilities;
 - (3) Parking district managed facilities.
 - c. A reduction in required parking up to fifteen percent (15%) may be granted by the Planning and Development Department Traffic Engineer under the following conditions.
 - (1) Required parking as per Table 1307.1 and Section 1307.B.d.
 - (2) Properties or businesses approved to share parking must be approved under a combined site plan.

D. Required Loading and Service Bays

1. On-site loading shall be required for all development as follows:
 - a. Loading bays are required in the amounts specified in Table 1307.3, calculated as the total area of each use category within a building;
 - (1) The areas of retail and office uses within a single building may be combined for use in Table 1307.3.
2. Loading docks and service areas are limited to the following locations:
 - a. At secondary frontages within 50-feet of the rear lot line.

- b. Where lots have no secondary frontage and lot width exceeds 120-feet, at primary frontages limited to 30-feet in length.

TABLE 1307.3. REQUIRED LOADING AND SERVICE BAYS
Square footage per net site area.

| USE | 25,000 – 40,000 SF | 40,000 - 160,000 SF | 160,001 - 320,000 SF | 320,001 - 400,000 SF | > 400,000 SF |
|---|--------------------|---------------------|----------------------|----------------------|-----------------------------|
| Multifamily Residential | 0 | 1 | 1 | 1 | 1 |
| Lodging | 0 | 1 / 300 rooms | 1 / 300 rooms | 1 / 300 rooms | 1 / 300 rooms |
| General Retail, Commercial and Office Uses | 0 | 1 | 2 | 3 | 1 per additional 180,000 sf |

| USE | 25,000 – 40,000 SF | 40,000 - 100,000 SF | 100,001 - 160,000 SF | 160,001 - 240,000 SF | > 240,000 SF |
|--|--------------------|---------------------|----------------------|----------------------|----------------------------|
| General Commercial and Industrial. Additional requirements per Section 1312. | 1 | 2 | 3 | 4 | 1 per additional 80,000 sf |

E. Off-street Parking Location and Access

1. Parking must be set back from frontages according to Table 1303.2, except where parking is located underground.
2. Where vehicular parking is required, parking may be fulfilled in the following locations:
 - a. Parking spaces provided within the lot.
 - b. Parking spaces provided along a parking lane (on-street) corresponding to lot frontages.
 - c. Parking spaces leased from a private or public parking facility.
 - (1) A shared parking agreement with the parking facility owner is required, specifying the number of leased spaces.

- (2) A pedestrian entrance to the parking facility must be within 1,320-feet, along a publicly accessible path, from a building entry providing access to the uses the parking spaces will serve.
 - d. Parking spaces managed by an established parking district.
3. Vehicular access to off-street parking is restricted as follows:
 - a. One access point (curb-cut) is permitted for every 100-feet of frontage except for T3 transect districts or if lot width narrower than 100-feet.
 - b. Lots with secondary frontages should not provide access points along the primary frontage. Driveways are allowed on the primary frontage if there is no alley or secondary right-of-way frontage.
 - c. Lots with alley access should provide a minimum of one vehicular access point from an alley. Refer to Section 1312 under specific Character Areas for modifications.
4. Pedestrian access to off-street parking should be provided from frontages, according to the following:
 - a. A minimum of one walkway, stair, or elevator access point should be provided between each lot frontage and off-street parking areas at or above sidewalk grade.
 - b. Pedestrian access walkways should be a minimum of 5-feet in width in T5 and 8-feet in T6. Exceptions identified in Section 1312.

F. Off-street Parking Design

1. Front setback from street right-of-way: Minimum 10-feet.
2. Side and rear landscape setback:
 - a. Adjacent to residential districts and Historic Preservation properties or districts: Minimum 10-feet. Trees should be placed 25-feet on center or equivalent group.
 - b. When adjacent to non-residential zoning district: zero-feet.

3. Surface parking as a primary use is limited to a period of 5 years, subject to a use permit.
 - a. At the conclusion of five years, the Zoning Adjustment Hearing Officer may allow an extension of the use permit for up to five additional years.
4. Surface parking lots should provide a minimum landscape screening as follows:
 - a. A minimum of one 2-inch caliper shade tree should be provided for every 10 vehicular parking spaces.
 - b. Vehicles should be screened by a 40-inch high decorative wall or solid evergreen hedge.
5. Off-street parking in T3 is not subject to the design requirements of this section.
6. Surface parking lots should be configured to share access point and circulation with adjacent surface parking lots, subject to a shared access agreement.

G. Parking Garage Design Guidelines.

1. The parking structure exterior should be finished with architectural embellishments and detailing that will create visual interest for adjoining properties and enhance the public right-of-way.
2. Lighting within the parking structures should provide safety and security.
3. Rooftop lighting should be set back a minimum of 25-feet from the perimeter of the rooftop parking structure and shall be a maximum of 12-feet in height.
4. There should be a convenient, clear, safe and efficient internal circulation system within the parking structure for both pedestrian and vehicular traffic including appropriate signage and placement of pedestrian circulation cores (elevators and stairs).
5. Appropriate visibility triangles and pedestrian crossings at exits and entrances should be provided in all parking structures.

6. Parking structures should not be adjacent to streets but should be adjacent to alleys if not adjacent to single-family residential or Historic Preservation properties or districts or be internal to the site.

H. Bicycle Parking.

1. Bicycle parking required may be placed in the frontage setback and may be allowed in the right-of-way subject to review by the Planning and Development Department Traffic Engineer.
2. Bicycle parking should comply with ADA requirements and not impede on-site pedestrian access. A clearance of at least four-feet in width must be provided for pedestrian access.
3. Bike racks and/or storage areas should be located within 50-feet from building entry points.
4. A bicycle rack should be a minimum of 30-inches from a wall or other obstruction. The minimum length for a bicycle parking should be 72-inches.

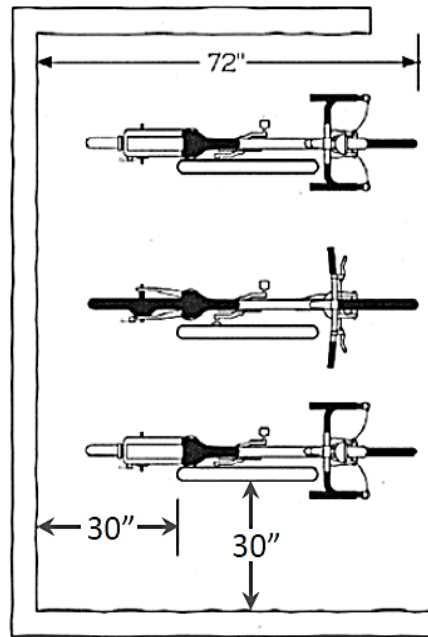

5. Bike racks and/or storage areas should be located near high traffic areas and visible to the public, but should not impede the function of the pedestrian way.
6. Bicycle parking and amenity standards.

- a. All non-residential uses over 5,000 square feet floor area shall provide one bicycle space per 25 vehicle parking spaces, with a maximum of 25 spaces.
- b. Dining and drinking establishments less than 5,000 square feet should provide a minimum of four bicycle spaces in the frontage setback and/or right-of-way if no vehicle parking is provided.
 - (1) When vehicle parking space is provided, additional one bicycle space for every 25 vehicle parking spaces should be provided.
- c. Commercial retail and office uses over 100,000 square feet in building area should provide a minimum of two shower stalls and ten lockers that are accessible to the building's occupants.
 - (1) Bicycle parking shall be provided at one space per 25 vehicle parking spaces, with a maximum of 50 spaces.
- d. Multifamily residential development should provide common bicycle parking at 0.25 spaces for each residential unit, with a maximum of 50 spaces.

SECTION 1308 SIGNAGE STANDARDS

A. Applicability

1. This Section establishes the standards for the number, size, placement, and physical characteristics of on-premise signs visible from a public way or adjacent property. These regulations do not restrict the content of on-premise signs nor signs invisible from a public way or adjacent property.
2. Relationship to Section 705:
 - a. Sections 705.A,B, C, E, F, G, and H apply in their entirety;
 - b. Section 705.D is replaced by this Section, with the exception of 705.D.8., 9., and 10.

B. Prohibited Signs

1. Signs with the following features are prohibited:
 - a. Signs placed above or on top of any portion of the roof or front parapet;
 - b. Signs utilizing animation or which contain the optical illusion of sign movement, except as provided by a use permit;
 - c. Inflatable signs, such as but not limited to balloons, gas inflated signs or similar inflated signs;
 - d. Portable signs, except for A-Frame signs as per Table 1308.1.
 - e. Commercial flags, banners, streamers, or other similar advertising devices;
 - f. Signs advertising goods or services not provided on the premises except for non-commercial signs
 - g. Yard signs

C. Permitted Signs and Sign Restrictions



1. Permitted sign types are limited by transect sub-district and the following restrictions according to Table 1308.1:



- a. The number of signs per sign type;
 - b. The area of signs;
 - c. The height of sign copy.
2. Additional sign restrictions apply per sign type according to Table 1308.2.
 3. A permit is required for the installation or modification of all signs as specified in Table 1308.1 as Permit.
 - a. Signs projecting into rights-of-way require an encroachment permit from the Street Transportation Department.
 - b. Signs not requiring a permit must meet all of the requirements of this section.
 4. All signs must provide the following clearance except where specified otherwise:
 - a. Minimum 8-feet over pedestrian ways;
 - b. Minimum 10-feet over vehicular ways and parking aisles.
 5. Illuminated signs are permitted as follows:
 - a. All signs may be illuminated by a light source external to the sign;
 - b. Internal sign illumination is limited to:
 - (1) Window and wall signs at storefront frontages;
 - (2) Ground and canopy signs;

D. Permit Conditions

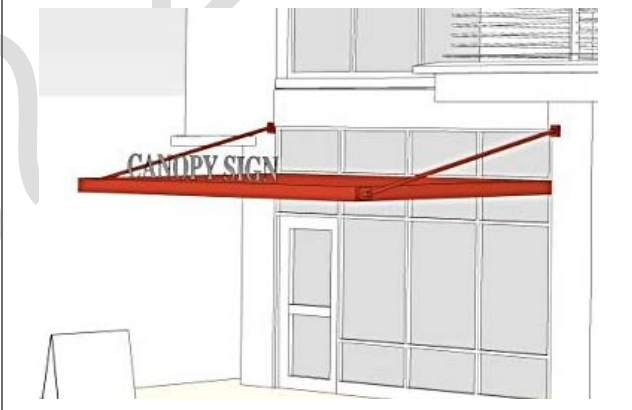
1. Wall signs on buildings in a designated Historic Preservation Zoning District exceeding applicable size regulations may be allowed by the Historic Preservation Commission in accordance with the procedure set forth in Section 812.C.3., and upon the additional finding that the proposed signage replicates the size, shape, and placement of the first permitted wall signage on the building.

| TABLE 1308.1. GENERAL SIGN RESTRICTIONS | | | | | | | | | |
|---|-----------|-----------|-----------|-----------|---------------|--------------------|--|---|---|
| SIGN TYPE | T3 | T4 | T5 | T6 | PERMIT | TIME PERIOD | SIGN NUMBER | MAX. SIGN AREA | MAX. COPY HEIGHT |
| Awning | | • | • | • | R | P | 1 sloping plane, plus 1 valence per awning | 75% of sloping plane; 75% area of awning valence | 16 in. on sloping plane; 8 in. on valence |
| Canopy | | | • | • | R | P | 1 per canopy | 2 sf per linear foot of storefront | 30 in. max. |
| Corner | | | • | • | R | P | 1 per building | 40 sf. | n/a |
| Directional | | | • | • | R | P | 2 per driveway | 6 sf. | n/a |
| Display Case | | | • | • | R | P | 1 per business | 6 sf. | n/a |
| Ground | • | • | • | • | R | P | 1 per frontage | 36 sf. | n/a |
| Kiosk | | | • | • | R | P | n/a | 24 sf. | 18 in. |
| Marquee | | | • | • | R | P | 1 per entry | 3 sf. per 1 linear ft. up to 90% of the width of tenant space | n/a |
| Projecting | | • | • | • | R | P | 1 per tenant | 6 sf. | 8 in. |
| A-Frame | | • | • | • | n/a | T | 1 per tenant | 9 sf. | n/a |
| Suspended | | • | • | • | R | P | 1 per entry | 6 sf. | n/a |
| Wall Sign | | | • | • | R | P | 1 per frontage | 3 sf. per 1 linear ft. up to 90% of the width of tenant space | 18 in. |
| Wall Mural Sign | | | • | • | R | P | 1 per frontage | see Table 1308.2 | n/a |
| Window | | • | • | • | R | P | n/a | 25% of glazed area | 12 in. |
| Window: Neon & LED | | | • | • | R | P | n/a | 25% of glazed aggregate area | 12 in. |
| PERMIT: (R) Required (n/a) Not Required | | | | | | | | | |
| PERMIT PERIOD: (P) Permanent (T) Temporary | | | | | | | | | |

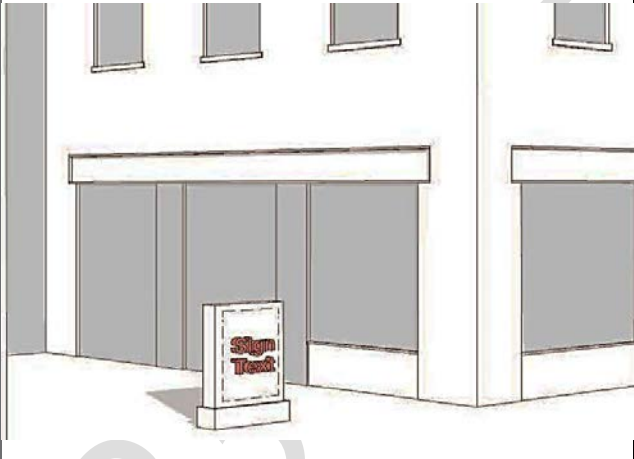
| TABLE 1308.2. SPECIFIC SIGN REGULATIONS | | |
|--|---|--|
| AWNING SIGN | | |
| Requirements | Valance sign area must maintain a minimum one-inch border. |  |
| CANOPY SIGN | | |
| Requirements | <p>Canopy signs may be externally illuminated, neon or LED.</p> <p>Fixtures must be shielded to prevent glare.</p> <p>Conduit, raceways, and wiring may not be exposed to view from the sidewalk.</p> |  |
| CORNER SIGN | | |
| Requirements | Corner signs may be located only at the corner of a building with both primary and secondary frontages. Internally or externally illuminated. |  |

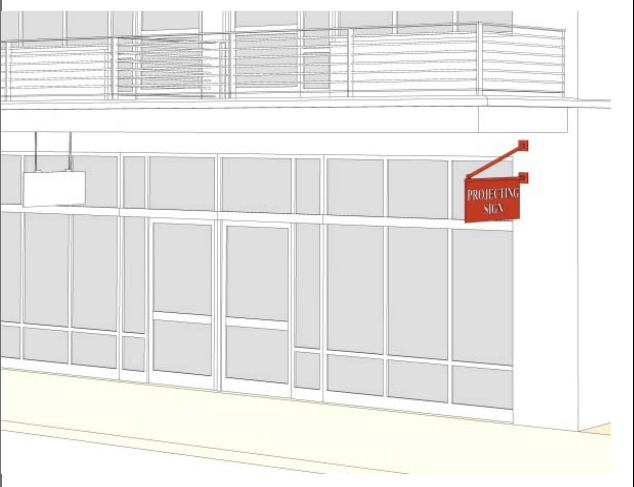
| TABLE 1308.2. SPECIFIC SIGN REGULATIONS | | |
|--|--|--|
| GROUND SIGN | | |
| Requirements | <p>Ground signs must be constructed of durable materials.</p> <p>Ground signs must be located within or interior to frontages.</p> <p>Ground signs located within 6-feet of buildings must be integrated into the building façade.</p> |  |
| MARQUEE SIGN | | |
| Requirements | <p>Marquee signs may project to within 2-feet of the curb. May require an encroachment permit.</p> <p>Marquee signs may be combined with a canopy sign or a projecting sign.</p> |  |
| PROJECTING SIGN | | |
| Requirements | <p>Projecting signs may project up to 3-feet from façades.</p> <p>Projecting signs may be double-sided.</p> |  |



| TABLE 1308.2. SPECIFIC SIGN REGULATIONS | | |
|--|---|--|
| A-FRAME | | |
| Requirements | <p>A-Frame signs may not be located within 3-feet of a curb.</p> <p>Maximum size: 3-foot high and 30 square feet if located within the public street setback.</p> <p>Sign may not block the sidewalk or ADA accessible route.</p> |  |
| WALL SIGN | | |
| Requirements | <p>Wall signs may be externally illuminated, neon or LED.</p> <p>Fixtures must be shielded to prevent glare.</p> <p>Conduit and wiring shall not be exposed.</p> |  |
| WALL MURAL SIGN | | |
| Requirements | <p>Only text or graphics painted directly on the wall or a graphic mural are permitted.</p> <p>Sign area is further restricted to 50-foot maximum width.</p> <p>Sign area is further restricted to 56-foot maximum height.</p> |  |

TABLE 1308.2. SPECIFIC SIGN REGULATIONS

| WINDOW SIGN | | |
|---------------------|---|--|
| Requirements | <p>The following window signs are permitted: letters painted directly on the window, neon signs, LED signs, hanging signs hung behind the glass, and vinyl applique letters applied to the window. Appliques must consist of individual letters or graphics with no visible background.</p> |  An architectural line drawing of a building facade. It features three large windows. The first window on the left has a sign that says 'WINDOW SIGN'. The second window in the middle also has a sign that says 'WINDOW SIGN'. The third window on the right has a sign that says 'WINDOW SIGN'. The building has a modern, clean design with a flat roof and a few smaller windows above the main level. The foreground shows a sidewalk and a street. |

DRAFT - 02-23-15

SECTION 1309 LANDSCAPE STANDARDS

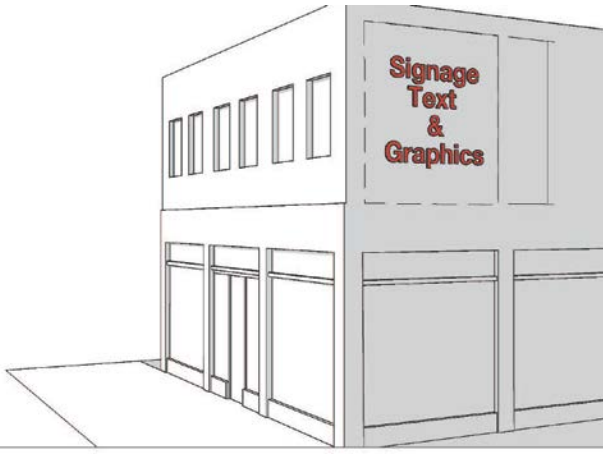
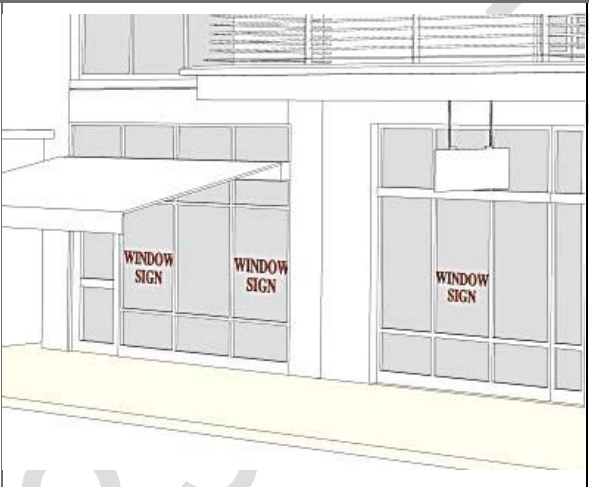
A. General Standards

1. Street trees and landscaping treatments shall be used for the entire site exclusive of building(s) and structural shade provided in accordance with the landscaping requirements in this section, unless there is a conflict with an existing or proposed public utility easement.
2. Planning and Development Department staff has the authority to accept modifications to landscaping requirements in the streetscape to accommodate public utility easement conditions, and to accept alternative design solutions consistent with a pedestrian environment.
3. If street trees cannot be planted in the right-of-way, architecturally or artistically integrated public amenities should be provided. Amenities may include but not be limited to the following:
 - a. Structural shade elements (may be cantilevered)
 - b. Seating (benches/chairs)
 - c. Public art elements
 - d. Community information/news event board/kiosk
 - e. Area wayfinding signage
 - f. Designer light fixtures
 - g. Additional bike racks
4. Streets furniture may be located within the planter area. Street furniture may be located on public sidewalks only when additional width is available in compliance with ADA accessibility requirements.

B. Planting Guidelines

1. Shade trees are limited to those specified in Table 1309.1. Additional Shade Trees may be approved if they are on the Arizona Department of Water Resources Phoenix AMA-3550 list. Tree locations in conflict with overhead power lines may use alternative tree species that are on the approved SRP or APS utility plant list.
 - a. Minimum caliper: two-inches

- b. Trees in the right-of-way should be placed 25-feet on center or equivalent grouping.
 - c. A minimum two-foot six-inch radius shall be clear of hardscape around the base of the tree.
 - d. At installation a minimum 30 percent of all trees shall have a minimum caliper of three inches.
 - e. 50 percent living vegetation ground coverage should be provided when a landscape strip is present or required as part of redevelopment.
 - f. When providing a double row of trees in the front setback or in the right-of-way, trees should be a minimum of two-inch caliper with 30 percent of all trees a minimum of three-inch caliper. The rows should be placed parallel on either side of the sidewalk and when possible, staggered, to provide for maximum shade.
2. Soil volume for shade tree planting is required according to tree spacing as specified on Table 1309.2 and as follows:
- a. Root paths, soil trenches, soil vaults, engineered soil solutions, and suspended sidewalk systems are permitted to meet soil volume requirements.
 - b. Up to 20 percent of required soil volume may be fulfilled by structural soil.
 - c. Soil compacted during construction should be excavated and water settled.
3. All trees planted within ten-feet of a public water/sewer main must comply with the Water Services Department's Design Standards Manual for Water and Wastewater Systems or as approved by the Water Services Department.
- C. Tree Species Guidelines.** The following should be used in accordance with the guidelines established below for type of trees within the WU Code.

| TABLE 1309.1 PERMITTED SHADE TREES | | | | | | | |
|---|---|-----------|-----------|-----------|-----------|--------------------|--------------------|
| BOTANICAL NAME | COMMON NAME | T3 | T4 | T5 | T6 | HEIGHT (FT) | SPREAD (FT) |
| Acacia salicina | Willow acacia | | | P | P | 30 | 20 |
| Acacia stenophylla | Shoestring acacia | P | P | P | P | 30 | 20 |
| Celtis reticulata | Netleaf hackberry | P | P | | | 25 | 25 |
| Dalbergia sissoo | Indian rosewood | P | P | P | P | 40 | 25 |
| Ebenopsis ebano | Texas ebony | P | P | | | 30 | 20 |
| Eucalyptus erythrocorys | Red-cap gum | P | P | P | P | 25 | 15 |
| Eucalyptus microtheca | Coolibah | P | P | P | P | 35 | 25 |
| Eucalyptus papuana | Ghost gum | P | P | P | P | 40 | 25 |
| Fraxinus velutina fan west | Fan west ash | P | P | P | P | 50 | 30 |
| Fraxinus velutina bonita | Bonita ash | P | P | P | P | 30 | 25 |
| Olea Europaea | Swan hill, Wilsonii, Majestic beauty - fruitless olives | P | P | P | P | 30 | 25 |
| Olneya tesota | Desert ironwood | P | P | | | 25 | 25 |
| Parkinsonia desert museum | Desert museum palo verde | P | P | | | 30 | 25 |
| Parkinsonia florida | Blue palo verde | P | P | | | 25 | 20 |
| Parkinsonia praecox | Palo brea | P | P | | | 25 | 25 |
| Pistacia chinensis | Chinese pistache | P | P | P | P | 40 | 25 |
| Prosopis South American hybrid | Thornless mesquite | P | P | | | 30 | 20 |
| Prosopis glandulosa | Honey mesquite | P | P | | | 30 | 30 |
| Prosopis velutina | Velvet mesquite | P | P | | | 25 | 35 |
| Quercus virginiana | Live oak | P | P | P | P | 40 | 30 |
| Ulmus parvifolia | Evergreen elm | P | P | P | P | 40-60 | 30 |
| UNDERSTORY TREES | | | | | | | |
| Acacia aneura | Mulga | P | P | P | P | 20 | 15 |
| Ceiba speciosa | Silk floss tree | P | P | | | 30 | 25 |

| TABLE 1309.1 PERMITTED SHADE TREES | | | | | | | |
|---|-----------------------|-----------|-----------|-----------|-----------|--------------------|--------------------|
| BOTANICAL NAME | COMMON NAME | T3 | T4 | T5 | T6 | HEIGHT (FT) | SPREAD (FT) |
| Chilopsis linearis | Desert willow | P | P | P | P | 25 | 20 |
| Chitalpa tashkentensis | Chitalpa | P | P | P | P | 25-30 | 20 |
| Havardia pallens | Tenaza | P | P | P | P | 25 | 15 |
| Pittosporum phillyraeoides | Willow pittosporum | P | P | P | P | 20 | 15 |
| Schinus terebinthifolius | Brazillian peper tree | P | P | | | 20 | 15 |
| Vachellia farnesiana | Sweet acacia | P | P | | | 20 | 20 |

| TABLE 1309.2 SHADE TREE SOIL VOLUME | | | |
|--|---------------------------------|---------------|----------------|
| Spacing | Soil Volume (Cubic Feet) | | |
| | 500 cf | 750 cf | 1000 cf |
| 30 feet | | | X |
| 25 feet | | X | |
| 20 feet | X | | |

D. Existing Landscape

1. Existing noxious or invasive plants species identified in Table 1309.3. should be removed.
2. Removal of existing plants meeting the following criteria should be minimized:
 - a. Trees with four-inch caliper or larger;
 - b. Native cacti three-foot and taller or non-native cacti six-foot and taller.

3. The root zones of existing trees and vegetation to be preserved should be protected from clearing or construction activities.

E. Prohibited Plants

1. The following plants are prohibited:
 - a. Artificial plants and artificial turf except at active recreation sports fields.
 - b. Noxious or invasive plants species as identified on the University of Arizona Non-native Invasive Plants of Arizona list and Table 1309.3.

| TABLE 1309.3 PROHIBITED PLANTS | |
|---|--|
| BOTANICAL NAME | COMMON NAME |
| <i>Arundo donax</i> (L.) | Giant cane, giant reed grass, elephant grass |
| <i>Pennisetum setaceum</i> (Forsk. Chiov) | Fountaingrass |
| <i>Rhus lancea</i> (L.) | African sumac |

SECTION 1310 OPEN SPACE IMPROVEMENTS

A. Open Space Guidelines.

1. Parcels zoned T3 are exempt from required public space improvements.
2. Open space requirements for commercial, nonresidential and mixed use development as follows:
 - a. For sites of one net acre or larger, minimum open space of at least five percent of the gross lot area shall be required.
 - b. A minimum of 50 percent of all accessible public and private open space areas should be shaded, of which 50 percent of the shade should be provided by trees or trellised vines.
 - c. Open space areas should be a minimum of 500 square feet with a minimum dimension of 20-feet.
3. Open space tree and landscaping requirements as specified in Section 1309 Landscape Standards.
4. Alternative paving materials should be used on private property to reduce urban heat island effect, and to allow natural drainage and filtration.
 - a. Permeable paving, porous concrete or similar materials should be installed adjacent to treewells. The design should ensure adequate watering and root growth.
 - b. Alternative materials such as brick pavers, permeable concrete pavers, granite and flagstone should be encouraged on walkways.

| PUBLIC OPEN SPACES | |
|---------------------------|---|
| Transect Zone | T4, T5, T6 |
| Size | Five percent of the gross site area above one acre. |
| Edge condition | One side minimum fronting a thoroughfare or pedestrian way. |
| Surface | Paved and landscaped. |

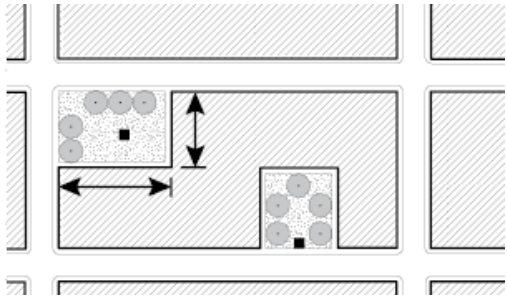

| TABLE 1310.1. PUBLIC SPACE TYPE GUIDELINES | | |
|---|--|---|
| Shade and Landscaping | 50 percent shade provided by trees Ground cover and shrubs: Should be provided in areas with no pavement or structures. | |
| PASEOS | | |
| Transect Zone | T4, T5, T6 | <p>The diagram illustrates a cross-section of a PASEO. It shows a central paved area flanked by landscaped zones. On the right side, there are several circular tree symbols of varying sizes, representing the shading requirements. The entire area is enclosed within a rectangular boundary with rounded corners.</p> |
| Guidelines | See Section 1304.H. | |
| Surface | Paved and landscaped. | |
| Shading | Minimum 75 percent shaded. | |

SECTION 1311 DESIGN DEVELOPMENT CONSIDERATIONS

A. General Considerations

1. Walking and bicycling should be encouraged within the urban districts of the City of Phoenix, particularly in support of transit services:
 - a. People should be provided the opportunity to walk, ride a bicycle, or use transit;
 - b. People should be provided the opportunity to drive less, and to park once and walk to nearby destinations;
 - c. Outdoor pedestrian activities within public rights-of-way should be encouraged;
 - d. A compact pattern of development and mix of uses should be encouraged in order to achieve increased walking and bicycling;
 - e. A high level of amenities, including public shade, should be provided for pedestrians' and other users' comfort and convenience;
 - f. An adequate level of access for automobiles should be maintained and their use integrated safely with pedestrians, bicyclists, and other users.
2. Transit use should be encouraged within proximity of existing and future transit service:
 - a. Uses that promote round-the-clock activity around transit stations should be encouraged;
 - b. Sufficient density of employees, residents, and recreational users are required to support transit.
3. Personal safety should be specifically considered in relationship to a transit supportive urban environment:
 - a. The public's safety should be protected by employing environmental design to promote situational awareness and by visually and physically defining the public and private realms;

- b. Sidewalks, pedestrian passages, streets and alleys should be adequately illuminated;
 - c. Illumination should not leave areas of contrast which permit concealment;
 - d. Lighting should not create glare for pedestrians or drivers.
4. Property owners' and users of the public realm should be provided adequate access to light and air:
- a. Property value and the healthfulness of the public realm should be protected by allowing equal access to light and air;
 - b. Urban heat-island effect should be limited by increasing access to light and air.
5. Parking should be regulated in order to support a walkable and transit-connected environment, providing for the needs of all users:
- a. The supply of parking should be adequate for the uses it serves;
 - b. The displacement of building and land uses by parking should be minimized;
 - c. Parking should be allocated to locations in which it will support, not interfere, with walkability;
 - d. Motor vehicle users should be able to park once to visit a variety of different destinations.
6. The public realm should be regulated to assist in support an active pedestrian-oriented realm and to cool streets, sidewalks, and buildings:
- a. Local microclimate and environment should be moderated through the application of trees and landscaping to:
 - (1) Improve air quality;
 - (2) Mitigate noise pollution;
 - (3) Provide seasonal shade, sun and temperature regulation;
 - (4) Reduce reflected light;

- (5) Mitigate wind gusts;
- (6) Provide a permeable barrier between sidewalks and vehicular lanes;
- (7) Reduce hot pavement;
- (8) Reduce runoff by intercepting and percolating rainwater;
- (9) Conserve soil and prevent erosion through vegetative cover, root growth, and windbreaks;
- (10) Conserve water through xeriscape and design strategies.

SECTION 1312 CHARACTER AREAS

A. Transit Gateway Character Area. Applicable to property within the Gateway Transit District Policy Plan area with Walkable Urban Code zoning.

1. Streetscape Standards.
 - a. Arterial Streets – Light Rail Corridor.
 - (1) Minimum sidewalk width: eight-feet (six-foot minimum allowed if density less than 12-units per acre)
 - (2) Minimum landscape width (if no conflict with public utilities): five-feet
 - b. Arterial Streets with no transit rail line or stations.
 - (1) Minimum sidewalk width: six-feet
 - (2) Minimum landscape width (if no conflict with public utilities): five-feet
 - c. Minor Collector and Local Streets.
 - (1) Minimum sidewalk width: five-feet
 - (2) Minimum landscape width (if no conflict with public utilities): five-feet
2. General Commercial and Industrial Uses
 - a. Land uses permitted under Sections 624 C-3 District - General Commercial, and 627 A-1 Light Industrial District are allowed for properties zoned General Commercial (C-3) and Industrial (A-1) prior to adoption of the WU Code as identified on the Gateway General Commercial and Industrial Land Use Map 1312.a.

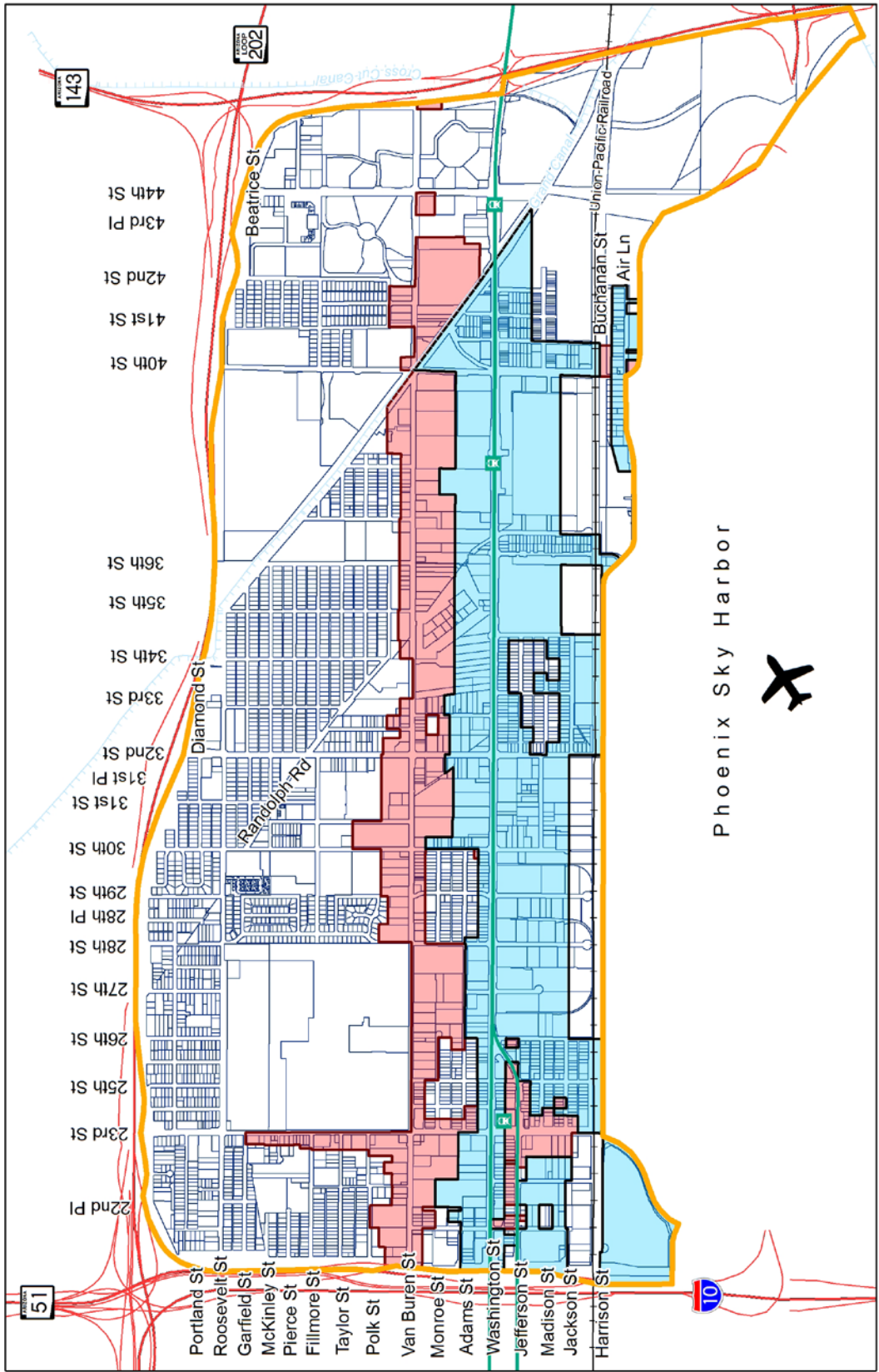

Map 1312.a.
Gateway General Commercial and Industrial Uses Regulating Map

Zoning Designation

- C-3 General Commercial
- A-1 Light Industrial

Gateway Transit-Oriented District

- Light Rail Line
- Light Rail Stop

Parcel Boundary

Scale: 0, 900, 1,800 Feet

City of Phoenix
 PLANNING AND DEVELOPMENT DEPARTMENT
P:\Planning\Projects\Revised Phoenix HUDOS\del\working\HUDOS\General Commercial and Industrial Uses Regulating Map.mxd

3. Existing General Commercial and Industrial Uses.
 - a. Expansion of general commercial and industrial uses is allowed for properties that were zoned Industrial (A-1) and Commercial (C-3) zoning prior to adoption of the WU Code as shown on Map 1312.A.2.a..
 - b. Additional square footage and structural improvements should follow the Planning Commission Policy for proportionate site improvements.
 - c. Special Considerations.
 - (1) Fences are allowed to be up to six-feet in height at the building setback. Fences must have decorative finish and undulate if over 50-feet in width. To reduce the incidence of graffiti, open view fence or a combination block-open view fence should be considered whenever possible.
 - (2) Pedestrian paseo and open spaces are not required as part of improvements.
4. New General Commercial and Industrial Use Standards.
 - a. Shaded walkways should be provided from the public sidewalk to primary building entrance.
 - b. Multiple tenant complexes should have primary entrances to each tenant space facing the street.
 - c. Parking and Loading. Loading and vehicle access doors should be located either:
 - (1) To the rear of the principal building(s) or,
 - (2) To the side of the principal building(s).
 - d. Placement and Massing.
 - (1) The primary building should be oriented toward the street.
 - (2) Industrial/Warehouse offices and lobbies should be located in the front of buildings adjacent to the street.

- (3) Loading docks and vehicle access doors should be located on the sides or rear of buildings to limit visibility from streets.
 - (a) A minimum eight-foot high street decorative screen wall should be provided to screen all loading and outdoor storage areas from off-site views.
 - (4) A minimum of a six-foot wide landscaping strip should be provided along the street side of the wall.
 - (5) A minimum 30 percent glazing should be provided for new single use industrial developments and minimum 50 percent glazing for a multiple tenant complex within the area from three feet to seven feet above adjacent sidewalk grade for frontages that face right of way.
 - (6) Buildings should not have massing that is boxy, bulky, or elongated. Large floor plates should be articulated or enhanced with façade and architectural features to break down the mass of the buildings.
- e. Parking for C-3 and A-1 uses identified in per Section 1312.A.2. shall follow the standards of Section 702.
- f. Special Considerations.
- (1) Fences are allowed to six-feet in height in the building setback. Fences must have decorative finish and undulate if over 60-feet in width. To reduce the incidence of graffiti, open view fence or a combination block-open view fence should be considered if possible.
 - (2) Pedestrian paseo requirements may be waived for new industrial uses, as long as it does not conflict with the Gateway Transit Policy Plan.
- g. Outdoor Storage or Use.
- (1) Outdoor storage allowed only on properties that were and Industrial (A-1) prior to the adoption of the WU Code per Map 1312.A.2.a.

- (a) Outdoor display areas fronting the Light Rail Corridor as per Section 627.C.3. Use permit required for all other properties.
- (2) Except for vehicle parking areas, no outdoor uses, outdoor storage, or open buildings shall be located within 75-feet of a public street or single-family zoning district.
- (3) Open storage shall be no higher than six-feet plus one-foot in height for every additional three-feet of setback from the property line.

B. Transit Eastlake-Garfield Character Area. Applicable to property within the Eastlake-Garfield Transit District Policy Plan area with Walkable Urban Code zoning.

1. Streetscape Standards.

a. Arterial Streets – Light Rail Corridor.

- (1) Minimum sidewalk width: eight-feet (six-foot minimum allowed if density less than 12-units per acre)
- (2) Minimum landscape width (if no conflict with public utilities): five-feet

b. Arterial Streets with no transit rail line or stations.

- (1) Minimum sidewalk width: six-feet
- (2) Minimum landscape width (if no conflict with public utilities): five-feet

c. Minor Collector and Local Streets.

- (1) Minimum sidewalk width: five-feet
- (2) Minimum landscape width (if no conflict with public utilities): five-feet

2. Special Considerations. Existing General Commercial and Industrial Uses.

- a. Expansion of uses are allowed for properties that had Industrial (A-1) and Commercial (C-3) zoning prior to adoption of the WU Code.
- b. Additional square footage and structural improvements should follow the Planning Commission Policy for proportionate site improvements.

C. Transit Midtown Character Area. Applicable to property within the Midtown Transit District Policy Plan area with Walkable Urban Code zoning.

1. Streetscape Standards.

a. Arterial Streets – Light Rail Corridor.

- (1) Minimum sidewalk width: eight-feet (six-foot minimum allowed if density less than 12-units per acre)
- (2) Minimum landscape/streetscape width: five-feet (if no public utility conflict)

b. Arterial Streets with no transit rail line or stations.

- (1) Minimum sidewalk width: six-feet
- (2) Minimum landscape width: five-feet (if no public utility conflict)

c. Minor Collector and Local Streets.

- (1) Minimum sidewalk width: five-feet
- (2) Minimum landscape width: five-feet (if no public utility conflict)

2. Special Considerations.

- a. Lots with alley access should provide a minimum of one vehicular access point from an alley unless adjacent to a single-family or historic zoning district or neighborhood.

- b. Where ground level retail uses are present, setbacks and build to dimensions may be increased up to 12-feet for outdoor seating, patio dining, or retail sales by securing a use permit.

D. Transit Uptown Character Area. Applicable to property within the Uptown Transit District Policy Plan area with Walkable Urban Code zoning.

1. Streetscape Standards.

a. Arterial Streets – Light Rail Corridor.

- (1) Minimum sidewalk width: eight-feet
- (2) Minimum landscape width: five-feet (if no public utility conflict)

b. Arterial Streets with no transit rail line or stations.

- (1) Minimum sidewalk width: six-feet
- (2) Minimum landscape width: five-feet (if no public utility conflict)

c. Minor Collector and Local Streets.

- (1) Minimum sidewalk width: five-feet
- (2) Minimum landscape width: five-feet (if no public utility conflict)

2. Special Considerations.

- a. Lots with alley access should provide a minimum of one vehicular access point from an alley unless adjacent to a single-family or historic zoning district or neighborhood.
- b. Where ground level retail uses are present, setbacks and build to dimensions may be increased up to 12-feet for outdoor seating, patio dining, or retail sales by securing a use permit.
- c. Property adjacent to the Grand Canal should integrate the canal into the project design.

E. Transit Solano Character Area. Applicable to property within the Solano Transit District Policy Plan area with Walkable Urban Code zoning.

1. Streetscape Standards.
 - a. Arterial Streets – Light Rail Corridor.
 - (1) Minimum sidewalk width: eight-feet
 - (2) Minimum landscape width: five-feet (if no public utility conflict)
 - b. Arterial Streets with no transit rail line or stations.
 - (1) Minimum sidewalk width: six-feet
 - (2) Minimum landscape width: five-feet (if no public utility conflict)
 - c. Minor Collector and Local Streets.
 - (1) Minimum sidewalk width: five-feet
 - (2) Minimum landscape width: five-feet (if no public utility conflict)
2. Special Considerations.
 - a. Lots with alley access should provide a minimum of one vehicular access point from an alley unless adjacent to a single-family or historic zoning district or neighborhood.
 - b. Where ground level retail uses are present, setbacks and build to dimensions may be increased up to 12-feet for outdoor seating, patio dining, or retail sales by securing a use permit.

SECTION 1313 DESIGN AND STANDARDS ALTERNATIVES

The Design Review Committee (DRC) shall oversee and approve design alternatives and standards appeals beyond the scope of Planning and Development Department (PDD) Director or designee approval as per Section 1313.B.

A design alternative is a deviation from the WU Code standards and design guidelines that results in a furtherance of the goals for an urban pedestrian environment. Design alternatives shall demonstrate conformance with the intent of the Wu Code and in general conformance with the Conceptual Master Plans and policies contained within Transit Oriented District Policy Plans.

A. Standards

1. Uses and height requirements may not be modified by PDD staff as part of site plan review or through the DRC appeal process.
2. The maximum combined PDD staff and or DRC modifications shall not exceed 35 percent.

B. Planning and Development Department staff may modify standards and design guidelines to accommodate existing conditions or as a design alternative, as follows:

1. Up to 25 percent from the prescribed standards for minimum/maximum setbacks; lot coverage; landscaping; and parking requirements.
2. Glazing and blank wall treatments may be modified by 15 percent.
3. Substitute methods of meeting the intent for frontage types may be approved in consultation with the PDD Planning Director or his/her designee.
4. PDD staff shall document the site specific justification for the design alternative(s) approval as part of the final site plan approval.
5. If design alternative cannot be approved by staff, the applicant may file an appeal with the Design Review Committee.

C. The following may be modified by the DRC as design alternatives:

1. Up to 25 percent for minimum/maximum setbacks; lot coverage; landscaping; parking, and glazing and blank wall treatments.

2. Substitute methods of meeting the intent for frontage types.
3. A design alternative shall be reviewed and acted upon by the DRC in accordance with the procedural requirements of Section 507 of the Phoenix Zoning Ordinance.
 - a. An approval from the DRC shall be included on the final site plan.

Attachment B. Transit Oriented Development Districts Map

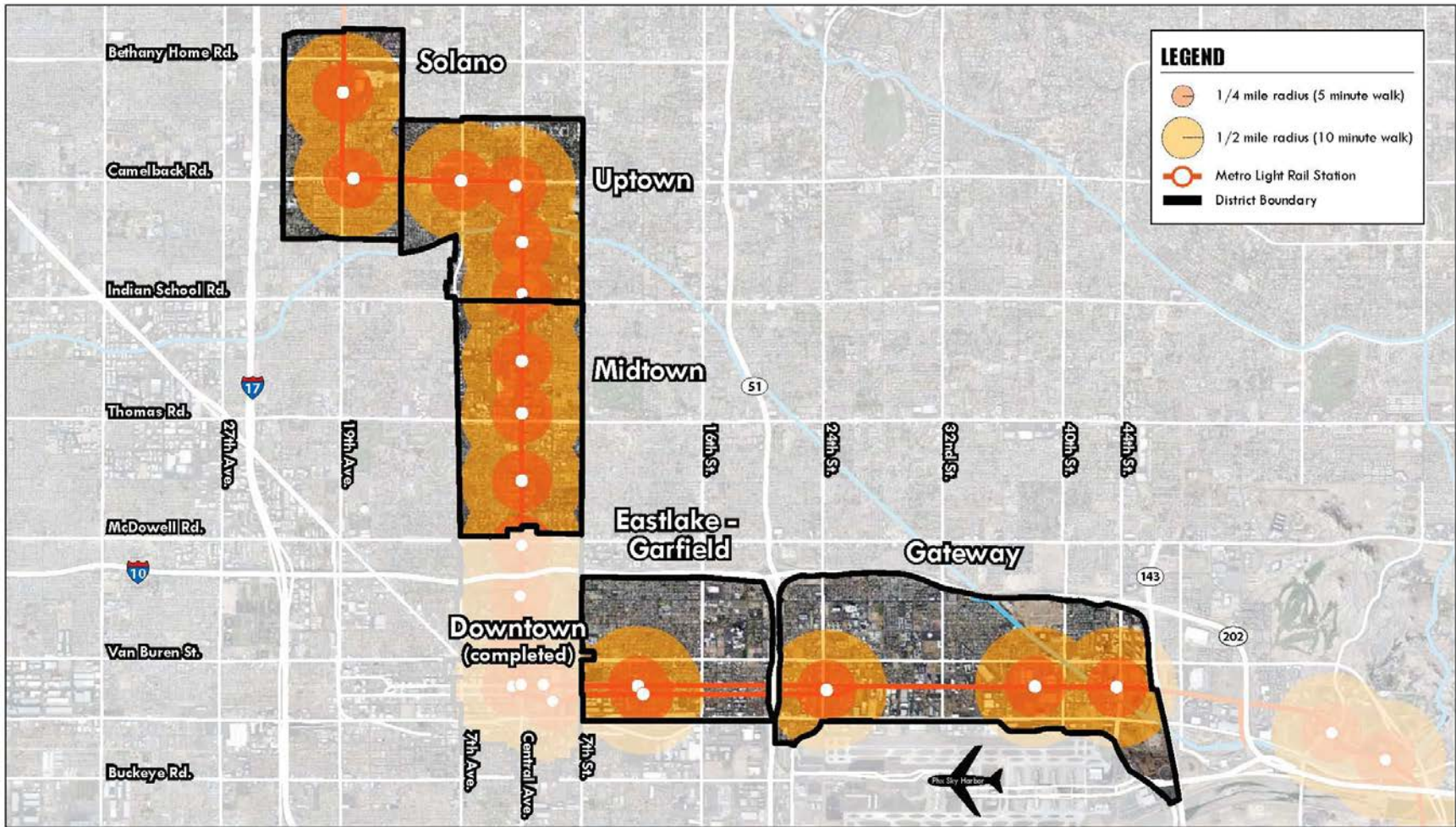

ReinventPHX
Project Map