

# STREET PLANNING AND DESIGN GUIDELINES MANUAL

JULY 2023



City of Phoenix

# TABLE OF CONTENTS

TABLE OF CONTENTS .....	i
Chapter 1 --- Introduction .....	1
Chapter 2 --- Geometric Design Standards .....	7
<b>2.1 INTRODUCTION .....</b>	<b>7</b>
2.1.1 COMPLETE STREETS .....	7
2.1.2 FLEXIBILITY IN DESIGN .....	7
2.1.3 RIGHT-OF-WAY ZONES .....	7
<b>2.2 SUMMARY OF GEOMETRIC DESIGN CRITERIA BY ZONE .....</b>	<b>8</b>
<b>2.3 TRAVEL LANE .....</b>	<b>10</b>
2.3.1 DESIGN SPEED .....	10
2.3.2 DESIGN VEHICLE .....	10
2.3.3 STREET CROSS-SECTIONS .....	12
2.3.4 TRAVEL LANE AND TURN-LANE WIDTH .....	17
2.3.5 PAVEMENT TRANSITION TAPERS .....	17
2.3.6 TURN LANES .....	17
2.3.7 MEDIANS .....	19
2.3.8 CURB TYPE .....	21
2.3.9 HORIZONTAL ALIGNMENT .....	22
2.3.10 VERTICAL ALIGNMENT .....	22
2.3.11 ALIGNMENT SIGHT DISTANCE .....	25
<b>2.4 FLEX ZONE .....</b>	<b>26</b>
2.4.1 BICYCLE FACILITIES .....	26
2.4.2 ON-STREET PARKING .....	26
2.4.3 TRANSIT .....	27
<b>2.5 PEDESTRIAN ZONE .....</b>	<b>28</b>
2.5.1 SIDEWALKS .....	28
<b>2.6 Intersections .....</b>	<b>29</b>
2.6.1 CURB RETURN RADII .....	29
2.6.2 INTERSECTION SIGHT DISTANCE .....	29
2.6.3 VISIBILITY FOR TRAFFIC CONTROL DEVICES .....	34
<b>2.7 Intersection Control Evaluation .....</b>	<b>34</b>
2.7.1 SCOPING .....	35

2.7.2 ALTERNATIVE SELECTION .....	35
<b>2.8 Roundabouts.....</b>	<b>36</b>
2.8.1 ROUNDABOUT CONSIDERATIONS.....	36
2.8.2 TRAFFIC VOLUMES.....	38
2.8.3 DESIGN SUBMITTAL AND REVIEW REQUIREMENTS.....	39
<b>2.9 Special Considerations .....</b>	<b>40</b>
2.9.1 CONSTRUCTION OF HALF-STREETS .....	40
2.9.2 STREET TERMINATIONS AND ALLEYS .....	40
<b>Chapter 3 -- Street Construction.....</b>	<b>43</b>
<b>3.1 Pavement Design .....</b>	<b>43</b>
3.1.1 DEFINITIONS.....	43
3.1.2 GEOTECHNICAL INVESTIGATION REQUIREMENTS.....	43
3.1.3 DESIGN PARAMETERS .....	43
<b>3.2 Culverts .....</b>	<b>46</b>
3.2.1 POURED-IN-PLACE REINFORCED CONCRETE ARCHES BRIDGES IN SUBDIVISIONS .....	46
3.2.2 CULVERTS UNDER HALF-STREETS .....	46
<b>3.3 Bridges and Major Structural Plans.....</b>	<b>47</b>
3.3.1 BRIDGES .....	47
3.3.2 STRUCTURAL CLEARANCES.....	48
<b>3.4 Cut or Fill Slopes .....</b>	<b>49</b>
<b>3.5 Pavement Transitions.....</b>	<b>50</b>
<b>3.6 Stormwater Management .....</b>	<b>50</b>
<b>3.7 Green Infrastructure .....</b>	<b>50</b>
3.7.1 PERMEABLE PAVEMENT.....	51
3.7.2 LOW IMPACT DEVELOPMENT CURB OPENINGS .....	51
3.7.3 SEDIMENT TRAPS.....	52
3.7.4 STORMWATER HARVESTING BASINS .....	52
3.7.5 VEGETATED OR ROCK BIOSWALES AND BIORETENTION SYSTEMS .....	52
3.7.6 DOMED OVERFLOW STRUCTURES .....	53
<b>3.8 Right-of-way Management Procedures .....</b>	<b>53</b>
<b>Chapter 4 -- Traffic Signal, Signing, and Striping.....</b>	<b>55</b>
<b>4.1 Introduction.....</b>	<b>55</b>
4.1.1 TRAFFIC DESIGN REFERENCES.....	55
<b>4.2 Traffic Signal Design .....</b>	<b>56</b>
4.2.1 DEVELOPER TRAFFIC SIGNAL WORK OVERVIEW.....	56

4.2.2 DEVELOPMENT REVIEW PROCESS.....56

4.2.3 TRAFFIC SIGNAL PLANS .....57

**4.3 Pavement Markings and Sign Plans .....58**

4.3.1 DESIGN – SIGNS AND PAVEMENT MARKINGS .....58

4.3.2 DEVELOPER REQUIREMENTS.....58

4.3.3 SIGNING.....58

4.3.4 PAVEMENT MARKINGS.....59

4.3.5 CITIZEN INITIATED REQUESTS.....59

**Chapter 5 --- Neighborhood Traffic Calming.....60**

**5.1 Introduction.....60**

**5.2 Resident Requested Traffic Calming.....60**

5.2.1 SPEED HUMP PROGRAM .....60

5.2.2 SPEED CUSHION PROGRAM.....61

**5.3 Traffic Calming Guidelines.....61**

5.3.1 CITY OF PHOENIX POLICIES.....62

5.3.2 TRAFFIC CALMING AND FUNCTIONAL CLASSIFICATION .....62

**5.4 Traffic Calming Strategies.....62**

5.4.1 SPEED HUMPS/CUSHIONS .....62

5.4.2 SPEED TABLES (RAISED CROSSWALKS) .....62

5.4.3 CHICANES .....64

5.4.4 CHOKERS .....65

5.4.5 CENTER ISLANDS.....66

5.4.6 T-INTERSECTION BULB-OUT.....68

5.4.7 NEIGHBORHOOD TRAFFIC CIRCLES .....68

**5.5 Maintenance.....69**

**Chapter 6 --- Access Management.....70**

**6.1 Introduction.....70**

**6.2 Greenfield vs. Existing/ Redevelopment .....70**

**6.3 External Agency Coordination.....71**

6.3.1 ARIZONA DEPARTMENT OF TRANSPORTATION.....71

6.3.2 ADJACENT MUNICIPALITY OR ENTITY.....71

**6.4 Access Management Summary .....71**

6.4.1 DISCLAIMER.....71

6.4.2 AUTHORITY OF STREET TRANSPORTATION DIRECTOR.....71

6.4.3 ACCESS MANAGEMENT GUIDELINES SUMMARY.....72

<b>6.5 Signalized Intersections</b> .....	<b>72</b>
6.5.1 SIGNALIZED INTERSECTION SPACING .....	72
6.5.2 URBAN, DOWNTOWN CORE, AND WALKABLE URBAN AREAS.....	73
6.5.3 SIGNALIZED ACCESS TO PRIVATE DEVELOPMENT .....	73
<b>6.6 Unsignalized Median Openings</b> .....	<b>73</b>
<b>6.7 Driveways</b> .....	<b>73</b>
6.7.1 SPACING .....	73
6.7.2 DRIVEWAYS FREQUENCY AND LOCATION .....	73
6.7.3 ALIGNMENT.....	74
6.7.4 CORNER CLEARANCE .....	75
6.7.5 NON-GREENFIELD/EXISTING CONSTRAINED ENVIRONMENT .....	76
6.7.6 DRIVEWAY WIDTH .....	77
6.7.7 ONE-WAY DRIVEWAYS .....	77
6.7.8 CROSS ACCESS AND COMMON DRIVEWAY .....	77
6.7.9 LIGHT RAIL CORRIDORS.....	78
<b>6.8 Auxiliary Turn Lanes</b> .....	<b>78</b>
6.8.1 RIGHT-TURN LANES.....	78
6.8.2 LEFT-TURN LANES .....	79
6.8.3 ANGLE OF ENTRY/EXIT AND DRIVEWAY THROAT LENGTH .....	79
6.8.4 DRIVEWAY SIGHT VISIBILITY TRIANGLE .....	80
6.8.5 INTERSECTION SIGHT VISIBILITY TRIANGLE .....	80
6.8.6 TURN RESTRICTIONS .....	82
6.8.7 ALLEYS.....	82
<b>6.9 Driveway and Intersection Spacing Near Roundabouts</b> .....	<b>83</b>
<b>6.10 Driveways at Bus Bays</b> .....	<b>83</b>
<b>Chapter 7 --- Subdivision Street Planning</b> .....	<b>84</b>
<b>7.1 Street Type and Arrangement</b> .....	<b>84</b>
7.1.1 LOCAL STREETS .....	84
7.1.2 COLLECTOR STREETS .....	85
7.1.3 ARTERIAL STREETS .....	85
<b>7.2 Street Design</b> .....	<b>85</b>
7.2.1 BLOCK LENGTHS.....	86
7.2.2 CUL-DE-SAC STREETS.....	86
7.2.3 KNUCKLES.....	86
7.2.4 EYEBROWS.....	87

7.2.5 ALLEYS.....	87
7.2.6 RESIDENTIAL SUBDIVISION STREET CROSS SECTIONS .....	87
<b>7.3 Block Design.....</b>	<b>87</b>
<b>7.4 Easement Planning.....</b>	<b>87</b>
7.4.1 STREET ABANDONMENT .....	88
7.4.2 STREET AND UTILITY IMPROVEMENT REQUIREMENTS.....	88
<b>Chapter 8 -- Bikeways and Active Transportation.....</b>	<b>91</b>
<b>8.1 Introduction.....</b>	<b>91</b>
8.1.1 PLANNING FOR ACTIVE TRANSPORTATION .....	91
<b>8.2 Bikeway System Components .....</b>	<b>92</b>
<b>8.3 On-Street Bicycle Boulevard.....</b>	<b>93</b>
<b>8.4 On-Street Bicycle Lanes.....</b>	<b>93</b>
8.4.1 BIKE LANES ON BRIDGES/TUNNELS/GRADE SEPARATION.....	93
8.4.2 BIKE LANES ON RURAL STREETS.....	93
8.4.3 BIKE LANES ON STREETS WITH ON-STREET PARKING/PARKING PROTECTED BIKE LANES.....	94
8.4.4 BIKE LANE WIDTH .....	94
8.4.5 BICYCLE STENCILS.....	94
<b>8.5 On-Street Buffered Bike Lanes .....</b>	<b>96</b>
<b>8.6 Protected Bike Lanes .....</b>	<b>98</b>
<b>8.7 Curb Inlets/Storm Drain Grates.....</b>	<b>99</b>
<b>8.8 Connections to Private Property .....</b>	<b>99</b>
<b>8.9 Shared-Use Paths .....</b>	<b>100</b>
8.9.1 DESIGN CONSIDERATIONS.....	100
8.9.2 EASEMENTS, DEDICATIONS, AND ABANDONMENTS .....	101
<b>8.10 Transit Stops.....</b>	<b>102</b>
<b>8.11 Rail Crossings.....</b>	<b>105</b>
<b>8.12 Transition Points and Ending Bicycle Facilities .....</b>	<b>105</b>
<b>8.13 Conflict zone Markings.....</b>	<b>106</b>
<b>Chapter 9 -- Traffic Impact Analysis .....</b>	<b>107</b>
<b>9.1 Introduction.....</b>	<b>107</b>
9.1.1 SCOPING PROCESS .....	107
9.1.2 CITY OF PHOENIX STREET CLASSIFICATION MAP .....	107
<b>9.2 City of Phoenix TIA Requirements.....</b>	<b>110</b>
9.2.1 SITE DEVELOPMENT PERMITS.....	110

9.2.2 ZONING APPLICATIONS .....	110
9.2.3 PLANNED COMMUNITY DEVELOPMENT (PCD) .....	110
9.2.4 PLANNED UNIT DEVELOPMENT (PUD) .....	110
9.2.5 DOWNTOWN CODE, WALKABLE URBAN CODE, AND TRANSIT-ORIENTED DESIGN DISTRICTS .....	110
9.2.6 GUIDELINES FOR TRAFFIC STUDY SCOPE .....	111
<b>9.3 Traffic Impact Study Content .....</b>	<b>112</b>
9.3.1 REQUIRED SECTIONS .....	112
9.3.2 REQUIRED FIGURES .....	113
<b>9.4 Special Considerations for Traffic Counts .....</b>	<b>113</b>
<b>9.5 Trip Reductions for Pass-by and/or Internal Trips .....</b>	<b>114</b>
<b>9.6 Off-Site Future Traffic .....</b>	<b>114</b>
<b>9.7 Level-of-Service Analysis .....</b>	<b>114</b>
<b>9.8 Auxiliary Turn Lanes .....</b>	<b>115</b>
9.8.1 INTERSECTIONS .....	115
9.8.2 SITE DRIVEWAYS .....	115
<b>9.9 Mitigation .....</b>	<b>116</b>
9.9.1 APPROACH TO MITIGATION .....	117
9.9.2 NON-AUTOMOTIVE NETWORK IMPACTS .....	117
9.9.3 NON-AUTOMOTIVE NETWORK ENHANCEMENTS .....	117
9.9.4 PEDESTRIAN FACILITIES .....	118
9.9.5 BICYCLE FACILITIES .....	118
9.9.6 TRANSIT FACILITIES .....	118
9.9.7 ROADWAY OPERATIONAL AND GEOMETRIC CHANGES .....	118
9.9.8 INTERSECTION CONTROL .....	119
<b>References .....</b>	<b>120</b>
<b>Chapter 2 .....</b>	<b>120</b>
<b>Chapter 3 .....</b>	<b>122</b>
<b>Chapter 4 .....</b>	<b>124</b>
<b>Chapter 6 .....</b>	<b>125</b>
<b>Chapter 8 .....</b>	<b>126</b>

# 1. INTRODUCTION

## OVERVIEW

The City of Phoenix has developed this updated Street Planning and Design Guidelines (SPDG) Manual to assist City staff and others with the planning and design of streets that reflect City of Phoenix policies and guidelines informed by multimodal planning best practices.

It is intended that application of the transportation design and planning principles outlined in this manual will improve safety for all users, including bicyclists, pedestrians, and transit users.

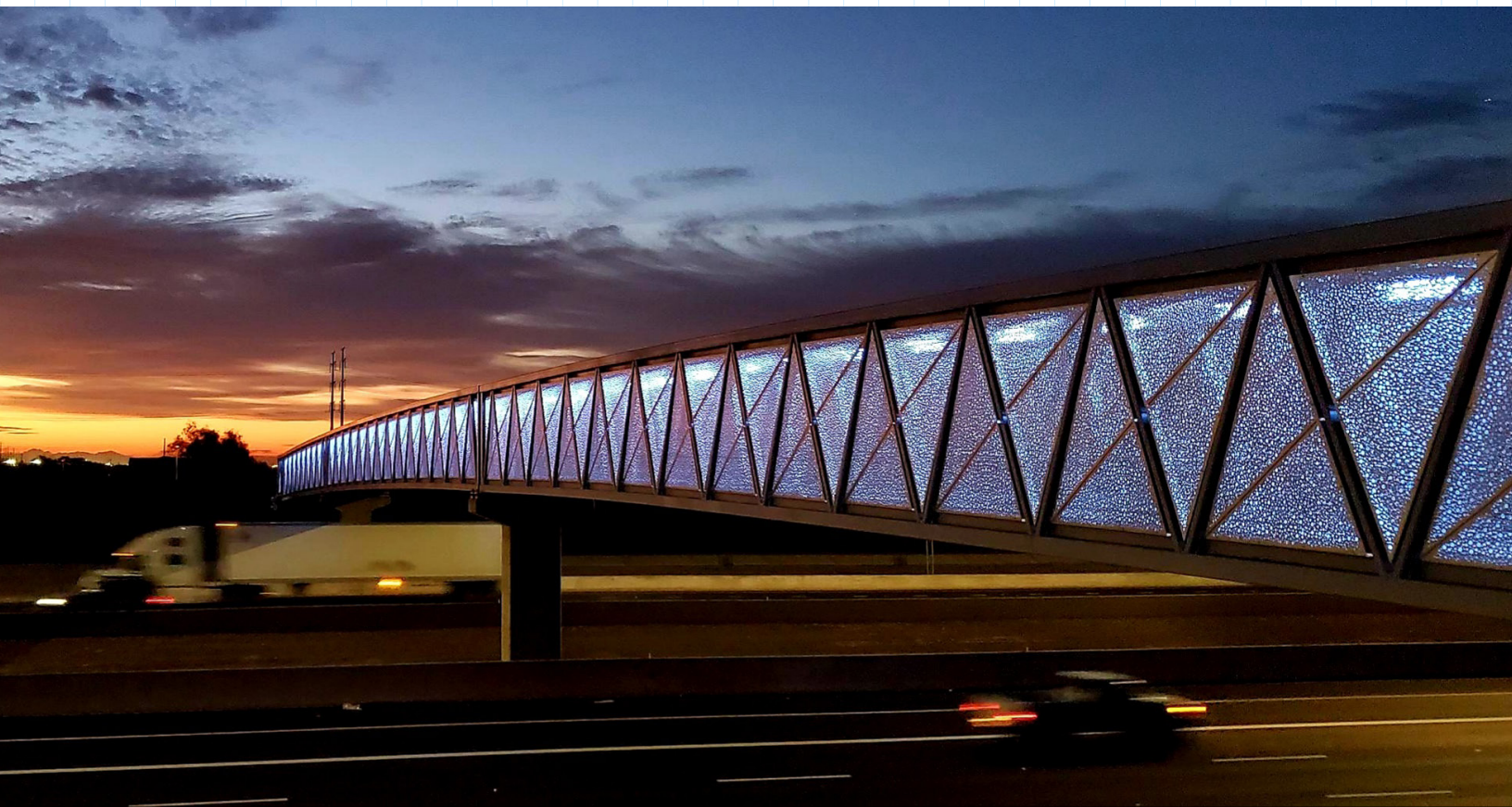





# 1

## 1.1 | AUTHORITY OF THIS DOCUMENT

These design guidelines, along with all future amendments, shall be known as the City of Phoenix Street Planning and Design Guidelines (hereinafter called “this manual”).

Preliminary approval of projects after adopted date **June 28, 2023** Ord. S-49991 shall fall under the requirements as outlined within this manual.

## 1.2 | PURPOSE OF THIS STREET PLANNING AND DESIGN MANUAL

The purpose of this manual is to provide concise, usable information to assist in transportation planning and road design.

This manual:

- *Integrates current adopted codes, plans, and policies that support the City’s proactive efforts to make the streets safer and more comfortable to use for all.*
- *Provides reference to other accepted local and national state of the practice planning and design standards, policies, and guidelines.*

This manual standardizes roadway design elements where necessary for consistency and to ensure, as practical, that minimum requirements are met for efficiency, safety for all users (vehicles, bicyclists, and pedestrians), welfare, convenience, pleasant appearance, environmental sensitivity and economical maintenance.

The guidelines outlined in this manual cannot apply to all situations. They are intended to assist the professional engineer’s judgment but not serve as a substitute. Professional engineers are expected to bring the best of their skills and abilities to each project so that it is designed in an optimal manner.

For items not covered by this manual, the City of Phoenix may require the use of the resource standards as identified in Section 1.4 below.

These guidelines are not intended to unreasonably limit any innovative or creative effort that might result in a higher quality or increased savings. Any proposed departure from these guidelines will be evaluated based on whether such exception will yield an equivalent or better result for the road users and City residents.

While every effort has been made to ensure the accuracy and completeness of this manual, the City of Phoenix shall not be held responsible for any errors or omissions. It is the responsibility of the design engineer to ensure a proper design and the accuracy and completeness of construction documents sealed and signed by a registered professional engineer.

## Vision, Goals and Objectives for Street Design in the City Of Phoenix

The overall philosophy of street design in the City of Phoenix is summarized in the Street Transportation Department Vision and Mission Statements:

### VISION

We will provide a safe and sustainable transportation network and deliver infrastructure services through a forward thinking and dedicated workforce to address the changing needs of the City.

### MISSION

To provide for the safe, efficient, and convenient movement of people and goods within the City and support citywide infrastructure projects to improve the quality of life in Phoenix.

To best address the changing needs of the City, this manual is a forward-looking manual and provides insights to emerging trends and potential future developments in transportation.

### OBJECTIVES

**1 EFFICIENCY, PUBLIC SAFETY AND CONVENIENCE.** To protect the public health, safety, and welfare to the greatest extent possible and minimize inconvenience resulting from construction and maintenance activities within the public right-of-way.

**2 MAINTAINING PUBLIC USE.** To assure that bicycle, pedestrian and vehicular uses of rights-of-way are the primary uses thereof, and that the rights-of-way are properly maintained during construction and repair work in these areas.

**3 STANDARDIZING CRITERIA.** To protect the City's infrastructure investment by establishing standardized design, materials, construction, and repair criteria for all public improvements.

**4 OPTIMIZING USE.** To optimize the use of the limited physical capacity of public rights-of-way held by the City of Phoenix.

**5 PROTECTING PRIVATE PROPERTY.** To protect private property from damages that could occur because of faulty design during the construction of public improvements within public rights-of-way.



## 1.3 CITY OF PHOENIX IS COMMITTED TO STREET PLANNING AND DESIGN FOR ALL USERS

Over the past several years, the City of Phoenix has completed several multimodal-focused plans and initiatives, such as the following:

1. Comprehensive Bicycle Master Plan and Comprehensive Downtown Transportation Study: 20-year plan to develop, growth and connect bicycle facilities in Phoenix.
2. Plan PHX and Reinvent PHX: commits to develop walkable, opportunity-rich communities connected to light rail.
3. Transportation 2050 Program: emphasizes street needs including; street maintenance, new pavement, bike lanes, sidewalks and ADA accessibility which will all compliment the increase in transit services; commits to new sidewalks and new bike lanes.
4. City of Phoenix Complete Streets Design Guidelines (adopted in 2018) advances Phoenix’s goal to create a multimodal transportation system that is safe and accessible for everyone. Complete streets provide infrastructure that encourages active transportation such as walking, bicycling, transportation choices and increased connectivity.

These advancements reflect the aspirations of elected officials, City staff, and residents to embrace a progressive approach to mobility, through context sensitive solutions that support neighborhood character, and provides mobility choices for a diverse population and their individual needs.

However, leveraging these investments into successful mobility is continually challenged by the diversity of needs and available choices. Public rights-of-way are being asked to provide more and more functions within existing footprints—“every road, every user, every function”. This City of Phoenix Street Planning and Design Guide is written to address this challenge and provides the information and guidance to plan and design streets that reflect and balance community context area sensitivity, roadway function, capacity requirements, right-of-way, and mode-specific plans/design considerations.

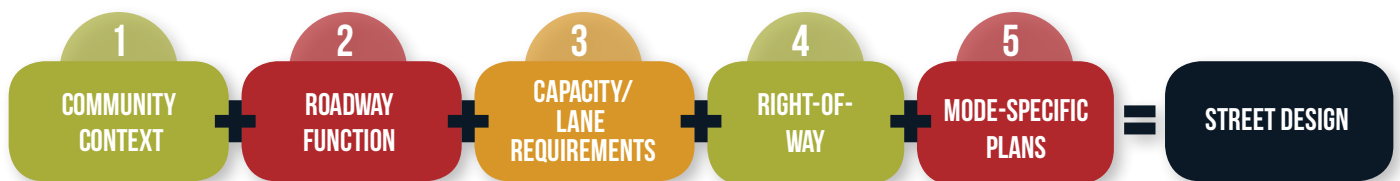

CONSIDERATION OF EACH STREET ELEMENT WILL HELP ALL STAKEHOLDERS TO NAVIGATE THE COMPLICATED QUESTIONS SUCH AS:

“Is there enough room to accommodate all of the desired features within the existing right-of-way?”

“How should this driveway be designed to maximize safety for pedestrians?”

“What does a separated bicycle facility look like on a City street?”

“How do I prioritize roadway design features when there is simply not enough room to accommodate all modes of travel?”

## 1.4 | RESOURCES

*Engineers and planners follow established standards and guidelines to prepare designs for roadway projects.*

### Relationship between this Manual and Other City Documents/Plans

This manual is intended to assist City staff and others with the planning and design of streets that reflect City of Phoenix policies and guidelines informed by multi-modal planning best practices.

Where possible, this manual refers to established policies, guidelines, and ordinances. **The user is directed to ensure that they are following the most current and recent version of the referenced document.**

### NATIONAL STANDARDS, POLICIES, AND GUIDELINES

- **AASHTO Guide for the Development of Bicycle Facilities, 2012 (PENDING PUBLICATION)**
- **AASHTO A Policy on Geometric Design of Highways and Streets (AASHTO Green Book), 7th Edition, 2018**, <https://store.transportation.org/item/collectiondetail/180>
- **FHWA Achieving Multimodal Networks: Applying Design Flexibility & Reducing Conflicts, FHWA-HEP-16-055, 2016**, [https://www.fhwa.dot.gov/environment/bicycle\\_pedestrian/publications/multimodal\\_networks/](https://www.fhwa.dot.gov/environment/bicycle_pedestrian/publications/multimodal_networks/)
- **FHWA Flexibility in Highway Design**, <https://www.fhwa.dot.gov/environment/publications/flexibility/flexibility.pdf>
- **Highway Capacity Manual - Seventh Edition: A Guide for Multimodal Mobility Analysis, 2022**, <https://nap.nationalacademies.org/catalog/26432/highway-capacity-manual-7th-edition-a-guide-for-multimodal-mobility>
- **ITE Designing Walkable Urban Thoroughfares: A Context Sensitive Approach, 2010**, <https://www.ite.org/pub/?id=e1cff43c%2D2354%2Dd714%2D51d9%2Dd82b39d4dbad>
- **NACTO Blueprint for Autonomous Urbanism - Second Edition, 2017, module 1**, <https://nacto.org/publication/bau/>
- **NACTO Transit Street Design Guide**, <https://nacto.org/publication/transit-street-design-guide/>
- **NACTO Urban Bikeway Design Guide - Second Edition, 2014**, <https://nacto.org/publication/urban-bikeway-design-guide/>
- **NACTO Urban Street Design Guide, 2013**, <https://nacto.org/publication/urban-street-design-guide/>

- **NCHRP Report 1043. Guide for Roundabouts, 2023**, <https://nap.nationalacademies.org/download/27069>
- **United States Department of Justice, 2010 ADA Standards for Accessible Design**, [https://www.ada.gov/2010ADASTandards\\_index.htm](https://www.ada.gov/2010ADASTandards_index.htm)
- **USDOT Manual of Uniform Traffic Control Devices for Streets and Highways**, <https://mutcd.fhwa.dot.gov/>

### STATE AND REGIONAL RESOURCES

- **ADOT Arizona Supplement to the 2009 Edition of the Manual of Uniform Traffic Control Devices for Streets and Highways, January 2012**, <https://azdot.gov/sites/default/files/2019/07/arizona-supplement-to-the-manual-on-uniform-traffic-control-devices-2009-mutcd-edition.pdf>
- **MAG Uniform Standard Details for Public Works Construction, 2023 Revision to the 2021 Edition**, <https://azmag.gov/Programs/Public-Works/Specifications-and-Details>
- **MAG Uniform Standard Specifications and Details for Public Works Construction, 2023 Revision to the 2020 Edition**, <https://azmag.gov/Programs/Public-Works/Specifications-and-Details>

### CITY OF PHOENIX POLICY DIRECTION

- **City of Phoenix Zoning Ordinance**, <https://www.codepublishing.com/AZ/Phoenix/>
- **PlanPHX, 2015 General Plan, Adopted March 4, 2015**, <https://www.phoenix.gov/pdd/planning-zoning/phoenix-general-plan>
- **Reinvent PHX - Transit-Oriented Development Policy Plans, 2015**, <https://www.phoenix.gov/pdd/reinvent-phx>

**BUILDING COMMUNITY REFERENCE MATERIAL**

- **2012 City of Phoenix Supplements to MAG**, <https://www.phoenix.gov/streetssite/Documents/092021.pdf>
- **2015 City of Phoenix Supplement to the 2015 Edition MAG Uniform Standard Specifications for Public Works Construction**, <https://www.phoenix.gov/streetssite/Documents/2015%20City%20of%20Phoenix%20Supplement%20to%20the%202015%20MAG%20Specifications.pdf>
- **2015 City of Phoenix Supplemental Standard Details for Public Works Construction**, <https://www.phoenix.gov/streetssite/Documents/2015%20City%20of%20Phoenix%20Supplemental%20Details.pdf>
- **Administrative Procedure 155 (Project Development Requirements and Guidelines)**, *February 2012*, <https://www.phoenix.gov/streetssite/Documents/ap155.pdf.pdf>
- **Developer Guidelines and AutoCAD Menus for Traffic Signal and Striping Plans**, <https://www.phoenix.gov/streets/reference-material/autoCADhelp>
- **City of Phoenix Traffic Signal Standard Details**, [https://www.phoenix.gov/streetssite/Documents/2020\\_CoP\\_Traffic\\_Signal\\_Standard\\_Details.pdf](https://www.phoenix.gov/streetssite/Documents/2020_CoP_Traffic_Signal_Standard_Details.pdf)
- **City of Phoenix Standard Specifications and Details for Public Works Construction, 2015 Edition**, <https://www.phoenix.gov/streetssite/Documents/City%20of%20Phoenix%20Specifications%20and%20Details%20for%20Public%20Works%20Construction,%202015%20Edition.pdf>
- **Design & Construction Management AutoCAD Standards**, <https://www.phoenix.gov/streetssite/Pages/DCM-AutoCAD-Standards.aspx>
- **SB1598 Licensing Time Frames**, <https://www.phoenix.gov/streetssite/Documents/091967.pdf>
- **Storm Water Policies and Standards Manual**, <https://www.phoenix.gov/waterservices/publications>
- **Street Classification Map**, [https://www.phoenix.gov/pddsite/Documents/PZ/pdd\\_pz\\_pdf\\_00175.pdf](https://www.phoenix.gov/pddsite/Documents/PZ/pdd_pz_pdf_00175.pdf)
- **Street Landscape Standards (2006)**, <https://www.phoenix.gov/streetssite/Documents/streetman.pdf>
- **Street Light Information for Development Projects**, <https://www.phoenix.gov/streets/reference-material/street-light-information-for-development-projects>

**OTHER CITY OF PHOENIX GUIDELINES, STUDIES, AND PLANS**

- **An Ordinance Establishing Complete Streets Guiding Principles**, *Ordinance S-41094, July 2014*, [https://www.phoenix.gov/streetssite/Documents/Complete\\_Streets\\_Principles\\_Ordinance.pdf#search=An%20Ordinance%20Establishing%20Complete%20Streets%20Guiding%20Principles%2C](https://www.phoenix.gov/streetssite/Documents/Complete_Streets_Principles_Ordinance.pdf#search=An%20Ordinance%20Establishing%20Complete%20Streets%20Guiding%20Principles%2C)
- **Complete Streets Design Guidelines**, *Adopted March 8, 2018*, <https://www.phoenix.gov/streetssite/Documents/CSAB%20Complete%20Streets%20Advisory%20Board%20Recommended%20Guidelines%20March%208%202018.pdf>
- **Comprehensive Bicycle Master Plan**, *November 2014*, <https://www.phoenix.gov/streetssite/Pages/Bicycle-Master-Plan.aspx>
- **Tree and Shade Master Plan**, *2010*, <https://www.phoenix.gov/oepsite/Documents/Tree%20and%20Shade%20Master%20Plan.pdf>
- **Phoenix Comprehensive Downtown Transportation Study: Final Study Report**, *September 2014*, <https://www.phoenix.gov/streetssite/Documents/Downtown%20Comprehensive%20Transportation%20Plan/Final%20Dwntwn%20Report.pdf>
- **Traffic Barricade Manual**, *9th Edition, 2017*, [https://www.phoenix.gov/streetssite/Documents/d\\_039129.pdf](https://www.phoenix.gov/streetssite/Documents/d_039129.pdf)
- **City of Phoenix Fire Code**, <https://www.phoenix.gov/fire/prevention/fire-code>

## 1.5 | MANUAL OVERVIEW

This manual is comprised of ten chapters. A brief overview of these chapters is provided as follows.

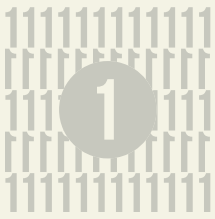

**INTRODUCTION:** This chapter introduces the purpose, vision and goals of the Street Planning and Design Guidelines Manual and provides links to local and national design standards and policies that are references for this Manual.



### GEOMETRIC DESIGN STANDARDS

Key topics include design considerations, pedestrian zone design, flex zone design (shared street areas that can be used for multiple purposes), roadway design, mobility zone design, intersections, crossings, and design details.



**STREET CONSTRUCTION:** This chapter provides information specific to the City of Phoenix and references source materials where possible. Topics include information on pavement thickness and approved asphalt mixes for street classes,

use of alternative paving materials, opportunities for incorporating other transportation improvements into the repair process, and stormwater management and green infrastructure construction.



### TRAFFIC SIGNALS, SIGNING, AND STRIPING:

An overview of relevant design standards and policies for traffic signal improvements are provided in this chapter. Requirements for level of improvements for new development and funding in escrow are discussed.



### TRAFFIC CALMING/TRAFFIC MANAGEMENT:

This chapter discusses traffic calming and traffic management policies. Requirements for level of improvements for new development and funding in escrow with respect to traffic calming and traffic management are discussed.



**ACCESS MANAGEMENT:** Topics discussed in this chapter include City of Phoenix requirements for:

- Driveways
- Frontage roads/ access roads
- Alleys
- Median spacing
- Median opening design
- Mid-block crossings
- Location of bus bays and pads



### SUBDIVISION STREET PLANNING:

Topics discussed include requirements of the Subdivision Ordinance and Zoning Ordinance (Chapter 32) and the Downtown Urban Walkable Code as well as information on cul-de-sac street lengths, private street and gated access design standards.

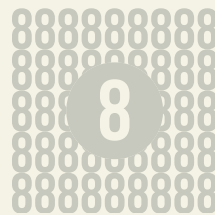

### BIKEWAYS AND PEDESTRIANS:

This chapter discusses integrating bicycle and pedestrian infrastructure into roadway design. This chapter provides design guidance on bikeway system components, shared use paths, transit stops, and rail crossings, among others.



### TRAFFIC IMPACT ANALYSIS:

This chapter is prepared to assist an applicant to satisfy the requirement of performing a Traffic Impact Analysis (TIA) when requesting access to a city street.

## 2. GEOMETRIC DESIGN STANDARDS

### OVERVIEW

Chapter 2 presents the geometric design standards for streets and roadways.

The design standards support Complete Streets principles, including safety for all travelers—pedestrians, bicyclists, transit users, and motorists



# Chapter 2 --- GEOMETRIC DESIGN STANDARDS

## 2.1 INTRODUCTION

Chapter 2 presents the geometric design standards for streets and roadways. The design standards support Complete Streets principles, including safety for all travelers—pedestrians, bicyclists, transit users, and motorists.

The design standards presented in this chapter are not a substitute for experience, professional judgment, or ongoing communication between the designers and reviewers. An exception process provides flexibility when necessary to accommodate site-specific opportunities and constraints. All exceptions will be evaluated based on whether it will provide an equivalent or better result for the road users and City residents. When reviewing and approving projects in City of Phoenix right-of-way, the City makes every attempt to balance the vision for a project with adopted policy, regulation, user acceptance, and public safety.

### 2.1.1 COMPLETE STREETS

The City of Phoenix adopted Complete Street Guidelines on March 8, 2018, contains the following design principles:

- Design for Safety, returning balance to the transportation network for users of all modes of transportation
- Design for Comfort and Convenience
- Design for Context
- Design for Sustainability
- Design for Cost-Effectiveness

A Complete Streets design approach using context-sensitive methods may result in variable design parameters, function, and appearance throughout the City based on community input, surrounding land uses, available right-of-way, street type, adopted general and specific plans and overall intent of the corridor in coordination with other city codes and ordinances.

### 2.1.2 FLEXIBILITY IN DESIGN

In many cases, existing right-of-way or utility requirements may not allow for the desired typical cross section to be constructed. Consistent with the desired function of the roadway, the design engineer must use engineering judgement to determine appropriate design values within limited or constrained right-of-way.

**“Design flexibility is of critical importance because each project has a specific purpose and need, has specific context and constraints, serves a unique set of users, and fills a unique position in the transportation network.”** — (AASHTO A Policy on Geometric Design of Highways and Streets)

### 2.1.3 RIGHT-OF-WAY ZONES

The City of Phoenix Street Classification Map defines right-of-way widths for City of Phoenix street cross-sections. The street cross section can be organized into three basic zones of the right-of-way, as illustrated in **Figure 2.1-1**.



- **Travel Lane:** Travel lanes can serve all modes or be dedicated to serve specific modes such as a bus or light rail.
- **Flex Zone:** Flex Zone is the space between the Travel Lane Zone and the Pedestrian Zone. This zone can contain multiple uses such as bike lanes, transit stops, commercial deliveries, on-street parking, taxi zones, passenger loading, and shared mobility areas. The Flex Zone serves as a buffer between moving vehicles in the Travel Lane Zone and the users in the Pedestrian Zone.
- **Pedestrian Zone:** This space includes the sidewalk, planting areas, bus shelters, street furniture, sidewalk cafes, and bicycle racks. It is always desirable to achieve preferred design widths to accommodate these features. At times accommodating preferred widths in urban settings is not possible due to various contextual constraints. When this occurs, design flexibility should be applied, and minimum widths considered where appropriate.

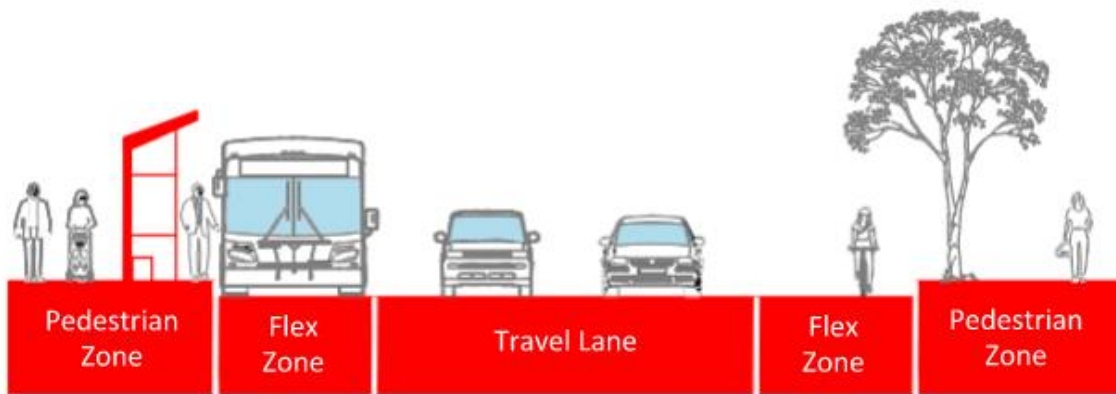

*Source: Adapted from Seattle Right-of-Way Improvements Manual, Standard 2.1 Right-of-Way Allocation, <https://streetsillustrated.seattle.gov/street-types/row-allocation/>*

*Figure 2.1-1 Right-of-Way Zones*

## 2.2 SUMMARY OF GEOMETRIC DESIGN CRITERIA BY ZONE

**Table 2.2-1** summarizes Geometric Design Criteria for each zone. Subsequent sections include additional discussion and detail regarding each zone. All street design should follow City Code 32-27.

Table 2.2-1 Roadway Geometric Design Criteria by Zone

Street Design Element	A	B	C	CM	D	E	F	G	H	I
	Major Arterial	Major Arterial & Arterial	Major Arterial & Arterial	Major Arterial & Arterial with Raised Median	Arterial and Major Collector	Collector	Minor Collector	Local Commercial & Multi-Family	Local (Single-Family Residential)	Local (Single-Family Residential)
<i>Design Speed</i>	Posted +10 mph	Posted +10 mph	Posted +10 mph	Posted +10 mph	Posted +10 mph	Posted +10 mph	Posted +10 mph	Posted +5 mph	Posted +5 mph	Posted +5 mph
<i>Right-of-Way Width</i>	140'	130'	110'	110'	100'	80'	60'	50'	50'	50'
<i>Pavement Width, Measured from Face of Curb to Face of Curb</i>	104'	94'	74'	74'	64'	50'	36 – 40' <sup>6</sup>	36'	32'	28'
<i>Number of Travel Lanes</i>	6	6	4	4	4	2	2	2	2	2
<i>Travel Lane Width (Typical)<sup>1</sup></i>	10' – 11'	10' – 11'	11'	11'	10' – 11'	12'	12' – 14'	-	-	-
<i>Median Width (Typical)</i>	24' Raised	14' Raised	12' Two-Way Left-Turn Lane	14' Raised	10' Two-Way Left-Turn Lane	10' Two-Way Left-Turn Lane	-	-	-	-
<i>Bicycle Lane Width (Min. Width)</i>	5.5' <sup>2</sup>	5.5' <sup>2</sup>	6'	5.5' <sup>2</sup>	6' <sup>3</sup>	6' <sup>7</sup>	6' <sup>7</sup>	-	-	-
<i>Curb Type<sup>4</sup></i>	Vertical	Vertical	Vertical	Vertical	Vertical	Vertical	Vertical	Vertical	Rolled Curb	Vertical
<i>Sidewalk<sup>5</sup></i>	5'	5'	5'	5'	5'	5'	4' – 5'	4' – 5'	4'	4'

**Note:**

1. 10' wide outside travel lane will typically only be considered in cases of limited pavement width, as a retrofit to accommodate on-street bicycle facilities. Final lane widths will be determined by Street Transportation Department.
2. 5.5' bicycle lane when combined with 2.5' buffer; otherwise, 6' bicycle lane required; buffer may require width of other travel lanes to be narrowed; bike lane width measured from face of curb. See Table 8.4.1 for details.
3. A bicycle lane may not be able to be accommodated in Cross-Section D. Lane widths will be determined by Street Transportation Department.
4. Refer to City of Phoenix supplement to Uniform Standard Specifications and Details for Public Works Construction for cross sections and elements including curb type.
5. City of Phoenix Downtown Code (DTC), Walkable Urban (WU) Code, or other zoning overlays supersede published sidewalk widths.
6. Rear facing home (F) allows for 36' wide section.
7. On-street parking may be added by removing the bike lane with Street Transportation Department approval.

## 2.3 TRAVEL LANE

### 2.3.1 DESIGN SPEED

Streets help define the character of neighborhoods. A street's design should interact with the surrounding context including its history, character, land uses, and nearby landmarks. Design speed contributes to the function and character of a street to be more walkable and bikeable, support investments in transit, foster social engagement and community pride, support the local economy and property values, and improve livability.

Design speed should be established considering surrounding land uses, available right-of-way, street type, adopted general and specific plans and overall intent of the corridor in coordination with other city codes and ordinances.

On City of Phoenix collector and arterial streets in typologies **outside of urban and downtown**, the **design speed is equal to the posted speed limit plus 10 MPH**. Design speed is governed by geometrics such as vertical and horizontal curves.

**Within urban core and downtown** street typologies, the design speed may be **equal to the posted speed limit**, in consultation with Street Transportation Department.

On local streets, the design speed is equivalent to the posted speed limit plus 5 MPH. Design speeds are shown in **Table 2.2-1**.

**Lower speeds are desirable for thoroughfares in walkable, mixed use urban areas and this desire for lower speeds should influence the selection of the design speed. For the design of such speeds, a target speed should be selected. (AASHTO A Policy on Geometric Design of Highways and Streets)**

### 2.3.2 DESIGN VEHICLE

The **design vehicle** is a frequent user of a given street and dictates the minimum required turning radius and lane widths for street intersections and driveways. The design vehicle should be able to make all movements on the street and at intersections without encroaching in the travel way of conflicting vehicles. If the design vehicle is too small or has too small a minimum turning radius, conflicts in the pedestrian zone or street edge may occur. If a vehicle is excessively large for the context, there may be too much space allocated for motor vehicles.

The **control vehicle** is an infrequent large user. A control vehicle dictates how an intersection accommodates a larger vehicle's turning needs. In some cases, the control vehicle can encroach on other lanes or overhang an area unlikely to be occupied by other road users. The decision is made considering the context of the surrounding land uses and priority of the roadway.

- The design vehicle in downtown and urban typologies is a SU-30 truck.
- The design vehicle in suburban and rural typologies is a BU-40 school bus.
- The control vehicle on all city streets is a 49-foot fire truck.
- The control vehicle on streets in industrial areas is a WB-67 interstate semitrailer.

Design vehicles and control vehicles are shown in **Figure 2.3-1** unless otherwise dictated by the values in **Table 2.2-1**.

**Downtown/Urban Areas: SU-30, 42-Foot Minimum Turning Radius**

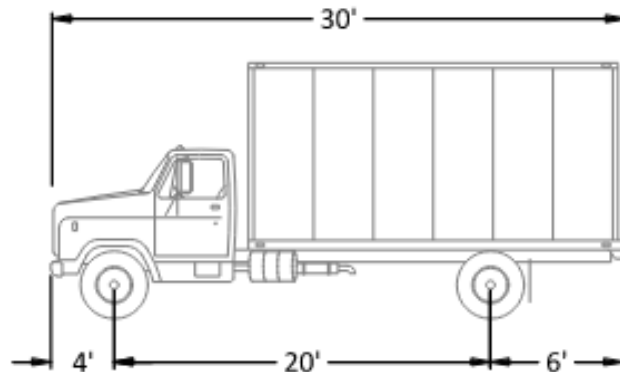

**Suburban/Rural Areas: School Bus, BU-40, 39.1-Foot Minimum Turning Radius**

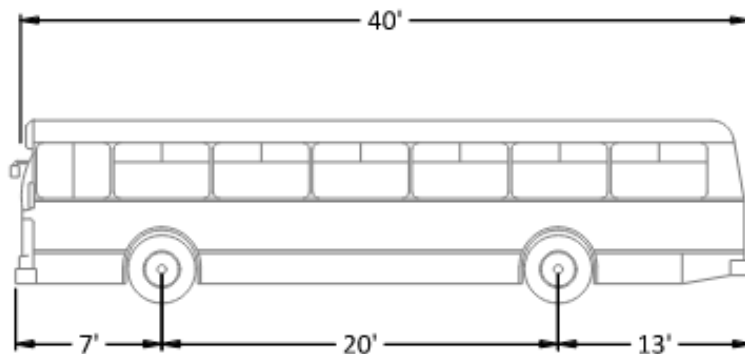

**Control Vehicle: Rear-Mounted Aerial Fire Truck**

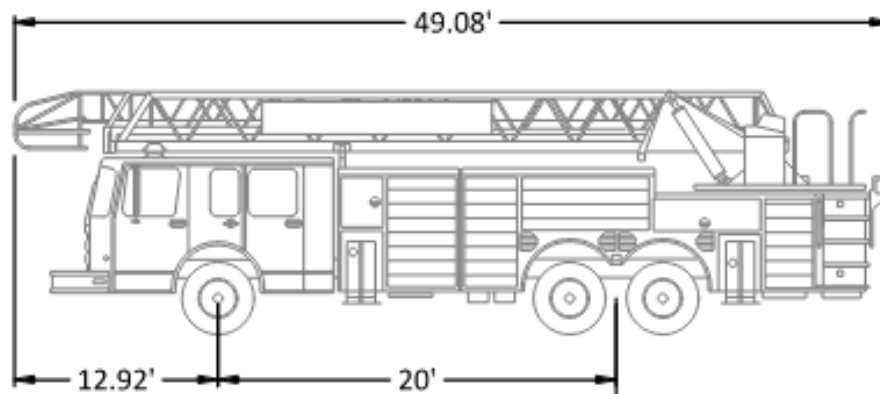

**Sources:**

SU-30 Design Vehicle: AASHTO, *A Policy on Geometric Design of Highways and Streets*, 7th Edition, 2018, Page 2-65.

BU-40 Design Vehicle: AASHTO, *A Policy on Geometric Design of Highways and Streets*, 7th Edition, 2018, Page 2-71.

Three Axle, Rear-Mounted Aerial Fire Truck, AUTOTURN program.

*Figure 2.3-1 Design Vehicle Illustrations*

### 2.3.3 STREET CROSS-SECTIONS

There are 11 street cross-sections (Figure 2.3-2 through Figure 2.3-12) based upon the type and level of use for which the streets are intended. The adopted street cross-sections are shown on the *Street Classification Map* for each arterial and collector within the City.

The corresponding figures show the geometric details of each of the cross-sections. **Lane dimensions are typical, and subject to striping review from Street Transportation Department.** Lane widths may be modified with approval from the Street Transportation Department. Pavement width, as measured from curb face to curb face, generally remains fixed.

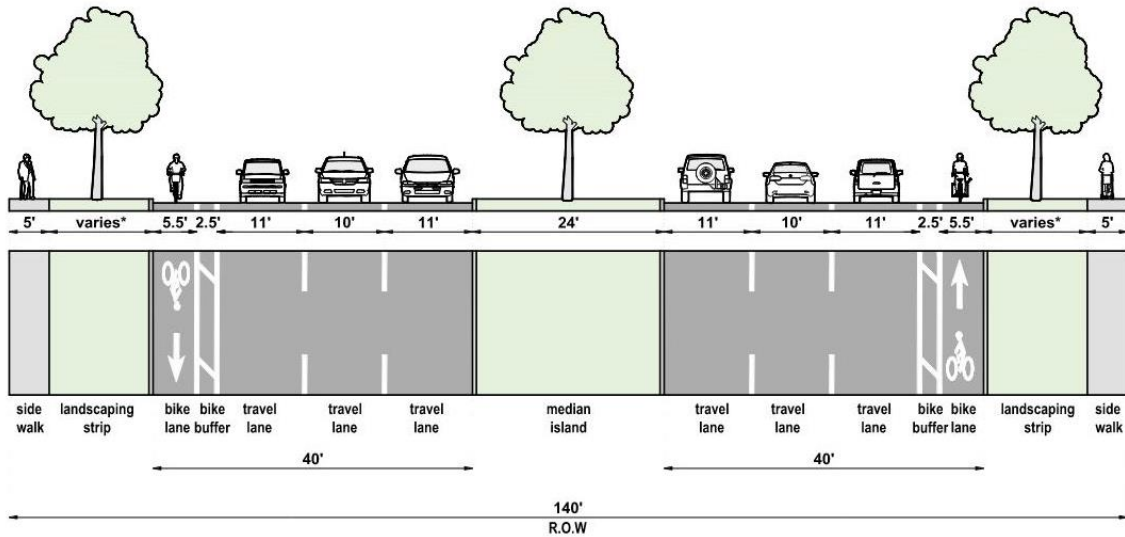

\*Preferred minimum width is 10', and is subject to character area, neighborhood, or specific plans.

Figure 2.3-2 Cross-Section "A," Major Arterial

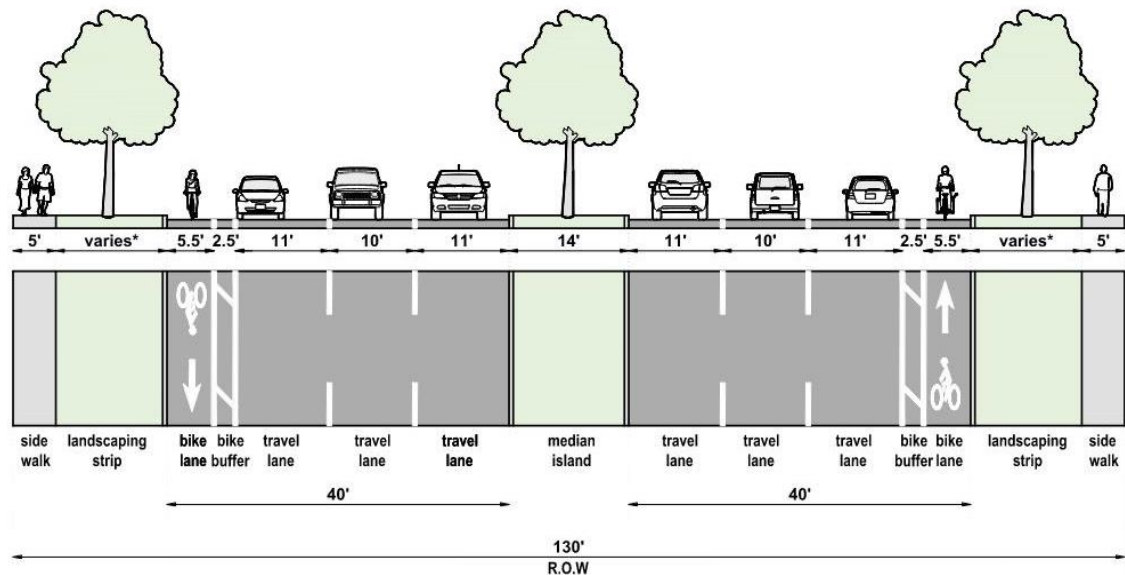

\*Preferred minimum width is 10' and is subject to character area, neighborhood, or specific plans.

Figure 2.3-3 Cross-Section "B," Major Arterial and Arterial

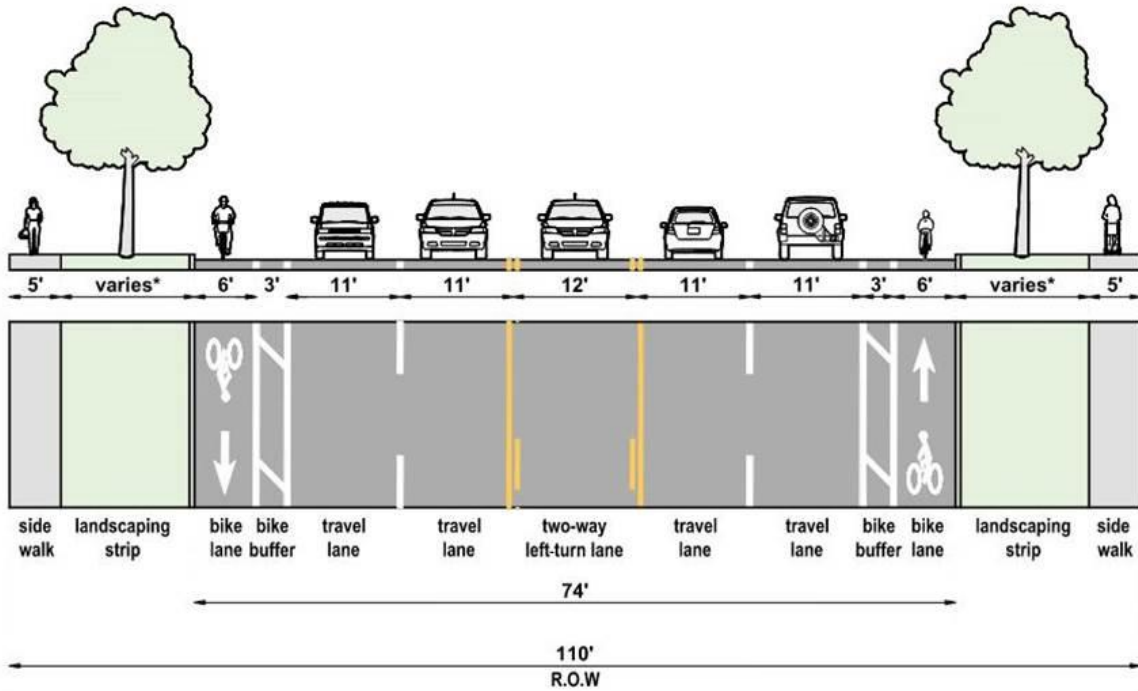

\*Preferred minimum width is 10' and is subject to character area, neighborhood, or specific plans.

Figure 2.3-4 Cross-Section "C," Major Arterial and Arterial

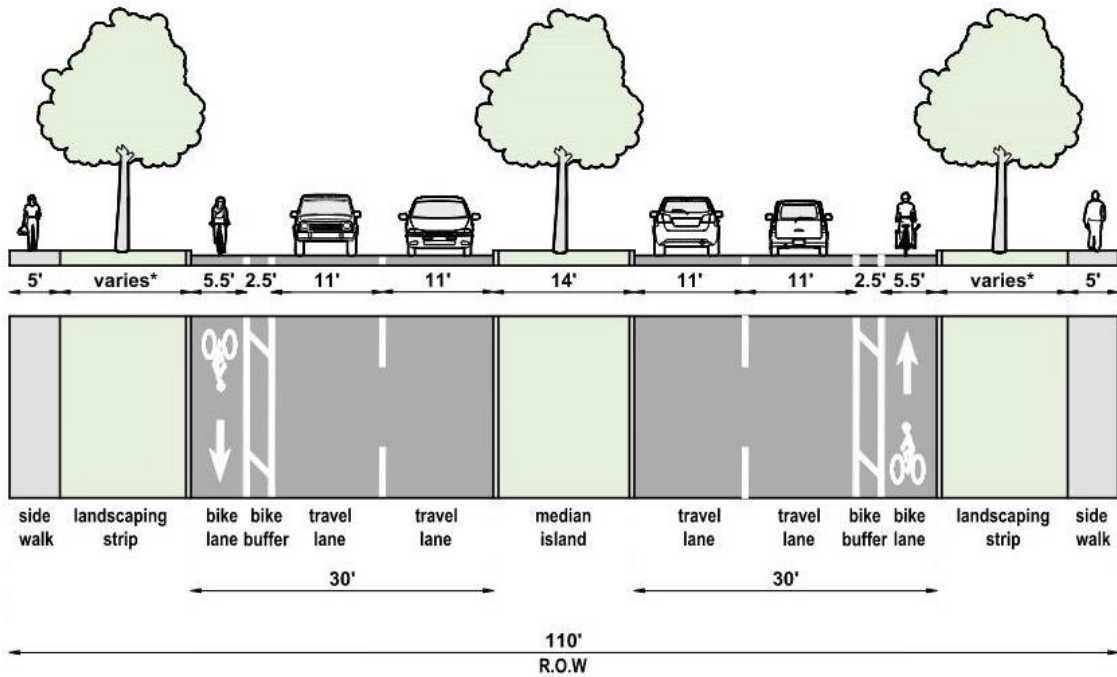

\*Preferred minimum width is 10' and is subject to character area, neighborhood, or specific plans.

Figure 2.3-5 Cross-Section "CM" (C with Raised Median), Major Arterial and Arterial

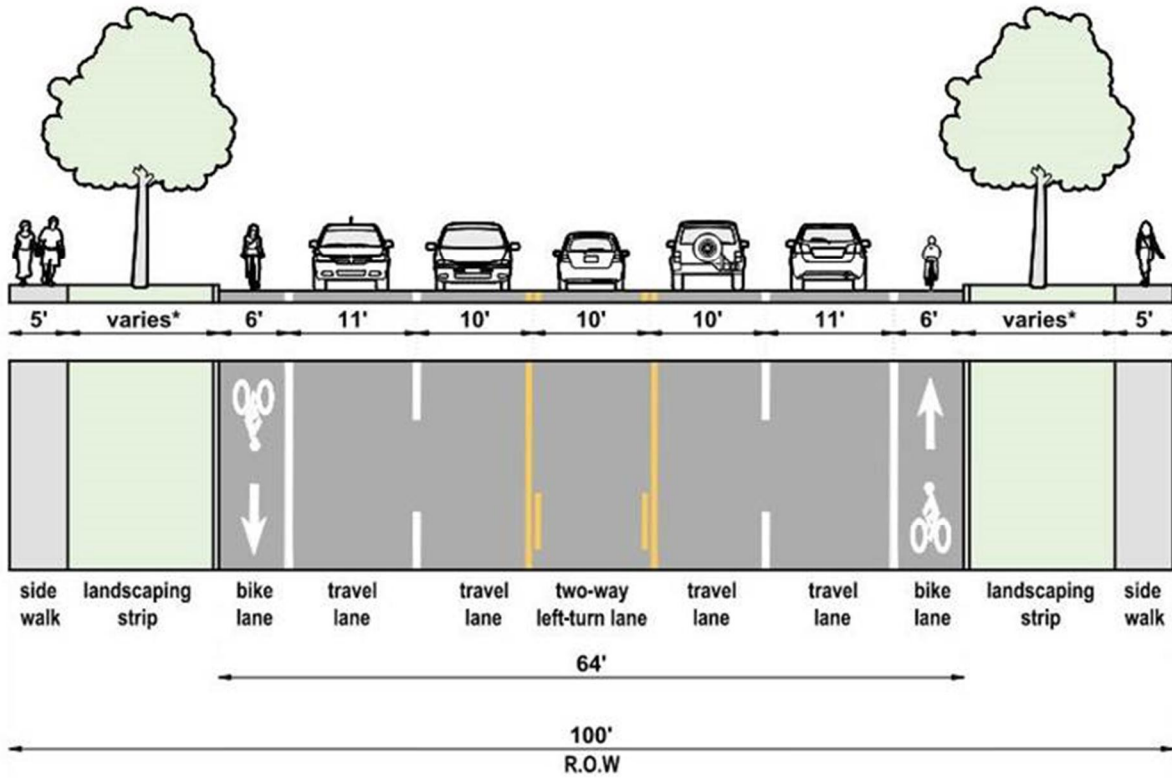

\*Preferred minimum width is 10' and is subject to character area, neighborhood, or specific plans.

Figure 2.3-6 Cross-Section "D," Arterial, and Major Collector

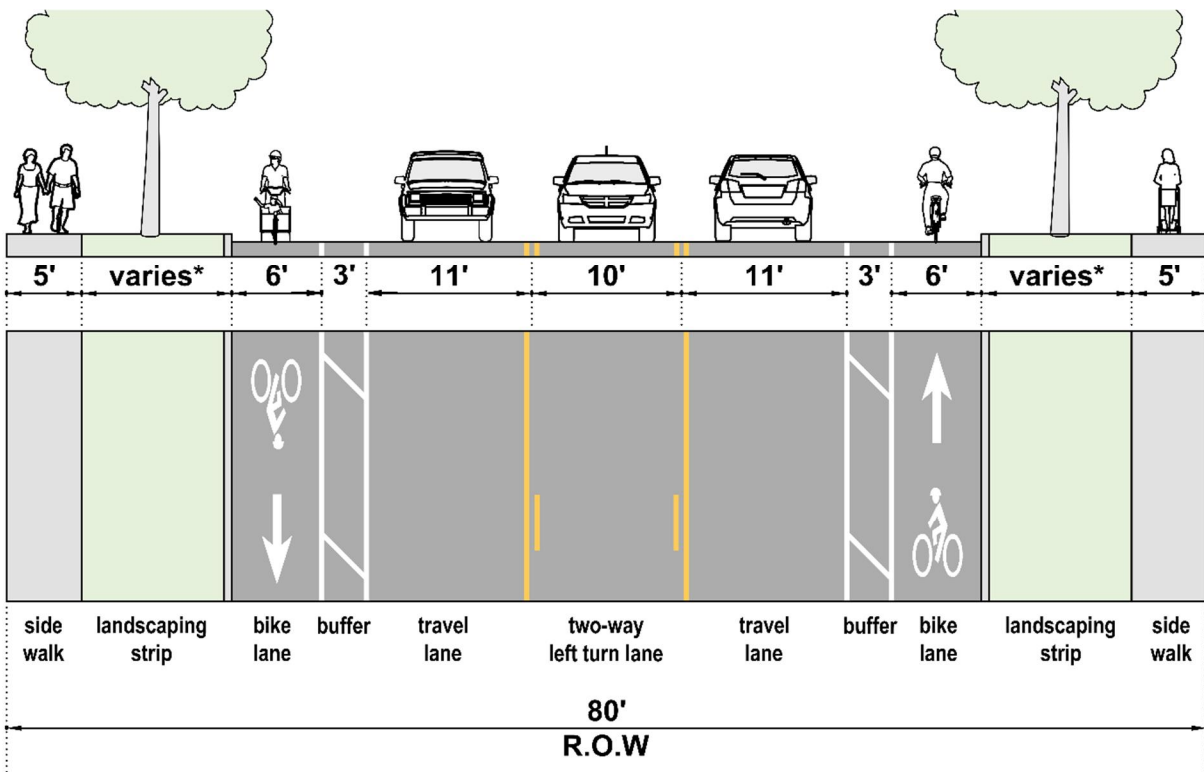

\*Preferred minimum width is 10', and is subject to character area, neighborhood, or specific plans.

Figure 2.3-7 Cross-Section "E," Collector

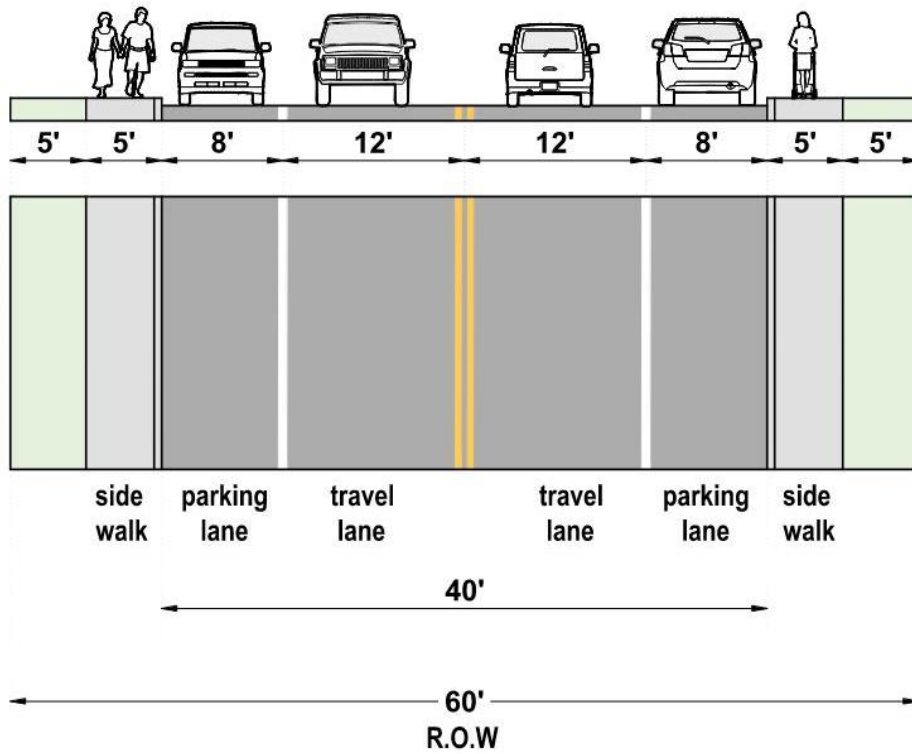

Figure 2.3-8 Cross-Section "F," Minor Collector with Parking

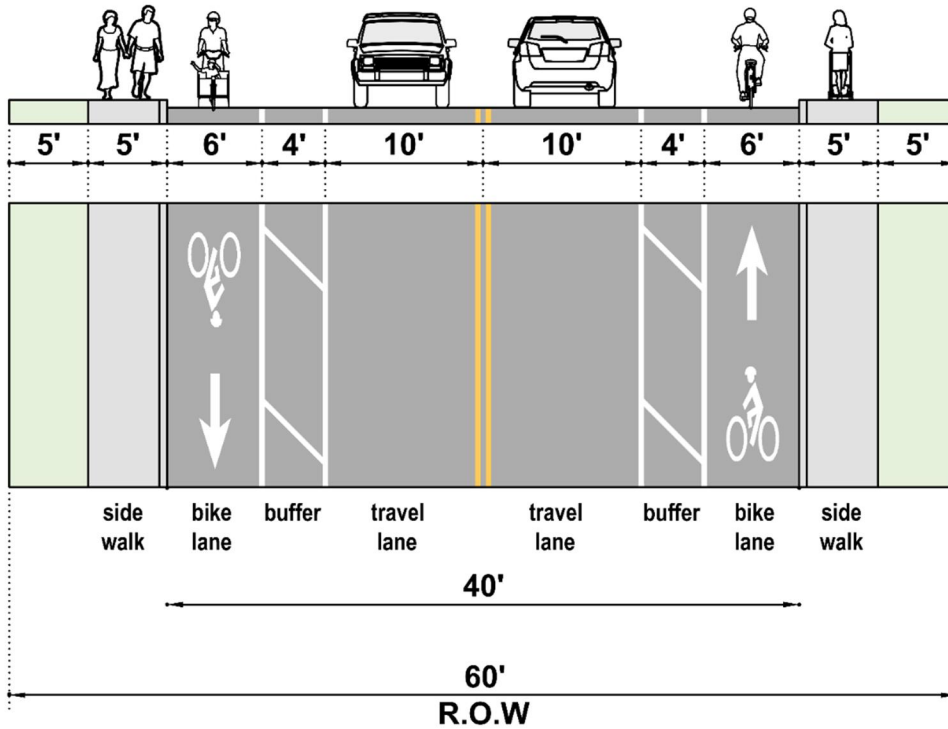

Figure 2.3-9 Cross-Section "F," Minor Collector with Bike Lane



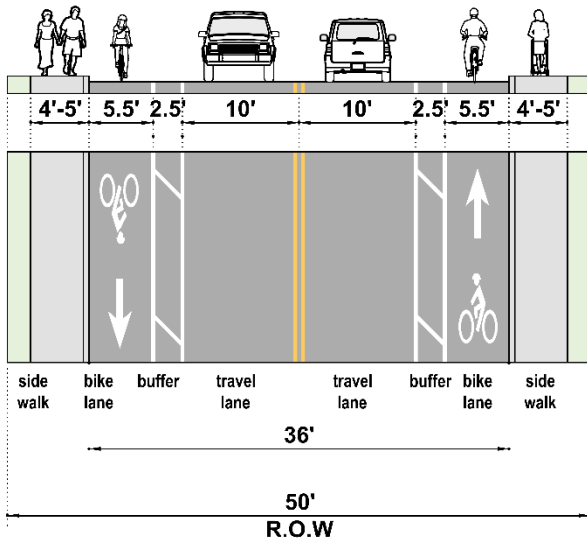

Figure 2.3-10 Cross-Section "G," Local (Commercial and Multi-Family)

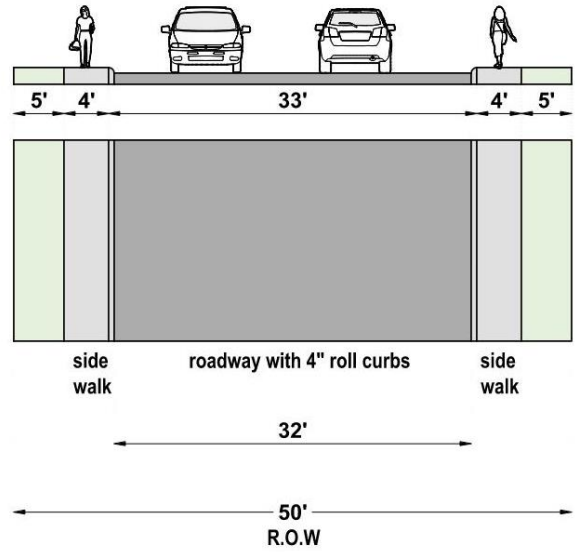
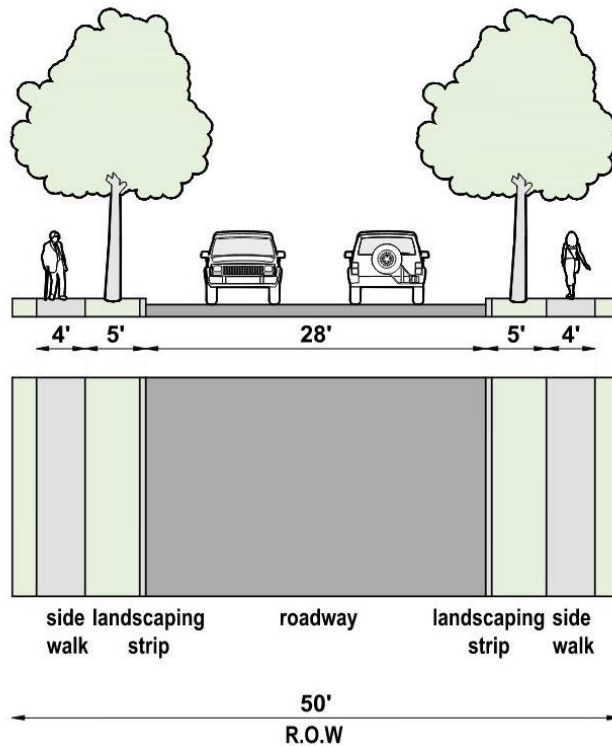

Figure 2.3-11 Cross-Section "H," Local (Single Family Residential)



\*Utilization of cross-section "I" requires approval of the Street Transportation Department, and adherence to Section 7.2.6 of this Manual.

Figure 2.3-12 Cross-Section "I," Local (Single Family Residential)

### 2.3.4 TRAVEL LANE AND TURN-LANE WIDTH

Travel lane widths are measured from the center of each longitudinal pavement marking lane line. Outside lane widths are measured to the face of curb and are inclusive of the gutter pan. Lane widths are specified in **Table 2.2-1. Chapter 4** contains additional information about pavement markings.

### 2.3.5 PAVEMENT TRANSITION TAPERS

AASHTO A *Policy on Geometric Design of Highways and Streets* specifies design criteria and guidelines for pavement tapers for lane transitions (**Figure 2.3-13**).

When development causes the widening of a portion of the pavement of an existing road, pavement transitions are required at each end of the widened portion. The transitions should be made on a tangent section whenever possible. Locations with horizontal and vertical sight distance restrictions should be avoided. Whenever feasible, the entire transition should be visible to the driver of a vehicle approaching the narrower section. Intersections at grade within the transition area should be avoided. A pavement taper is required regardless of the striping transition in the adjacent area.

#### Transition to a Wider Pavement Section

If right-of-way is available, a transition from a narrower cross-section to a wider cross-section should have a taper that is 25:1. Additional taper length may be required based on the location of cross streets and driveways downstream from the new improvements.

#### Transition to a Narrower Pavement Section

If right-of-way is available, a transition from a wider cross-section to a narrower cross-section should have a length equal to the difference of the two (2) widths in feet times the street design speed in miles per hour.

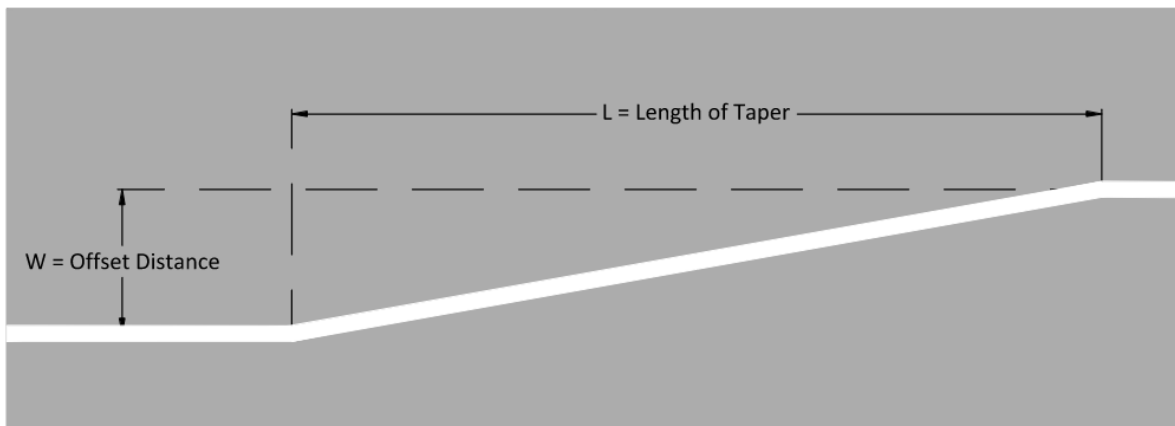

Source: Adapted from AASHTO Green Book, *Straight Line Taper*, page 9-103

Figure 2.3-13 Lane Transition Tapers

### 2.3.6 Turn Lanes

#### Right-Turn Lanes

At intersections or driveways, the width of a right-turn lane is 12' measured from face of curb to center of longitudinal lane line.

Typical storage length is 100' from curb return or driveway wing. The maximum allowable storage length is 250' and must be supported by a traffic study. Right-turn storage lengths at an intersection shall be per Table 2.3-1 and 2.3-2.

The taper length may be calculated by applying a taper rate of 8:1 for design speeds up to 30 mph; for 35 mph and 45 mph design speed the taper length may be 125'; and 180' for design speeds 50 mph and greater.

Continuous right-turn lanes between driveways will not be allowed. There will be a minimum of 20' from curb return/wing of driveway to the start of the approach taper for the next right-turn lane.

**Left-Turn Lanes**

Left-turn lane storage requirements are subject to a traffic engineering study. Storage lengths are typically as follows in **Table 2.3-1** and **Table 2.3-2**.

For high-speed rural highways, deceleration distances and large truck volumes must be considered when determining the total left-turn lane length.

Any left-turn storage lengths that differ from the guidelines must be reviewed and approved by the Traffic Services Division of the Street Transportation Division.

Refer to Detail 7336<sup>1</sup>, Intersection Flare, available from Street Transportation Department for lane transitions. The detail shows transitions for addition of through lanes, right-turn lanes, and left-turn lanes for each cross-section. A representative depiction of how a Cross-Section F transitions to include taper and turn lane is shown in **Figure 2.3-14**.

*Table 2.3-1 Arterial Street Turn Lane Storage*

<i>Intersection Type</i>	<i>Arterial Street Storage Length</i>
<i>Intersection with Arterial Streets (including dual left turns)</i>	250' <sup>1</sup>
<i>Intersection with Collector Streets</i>	150'
<i>Intersection with Local Streets</i>	100'
<i>Intersection with Driveways</i>	100'

<sup>1</sup>Dual left-turn lanes are required when vehicle queue exceeds 250'.

*Table 2.3-2 Collector Street Turn Lane Storage*

<i>Intersection Type</i>	<i>Collector Street Storage Length*</i>
<i>Intersection with Arterial Street</i>	100'

\*Collector street turn lanes may be required based on TIA recommendations

<sup>1</sup> <https://www.phoenix.gov/streets/reference-material/>

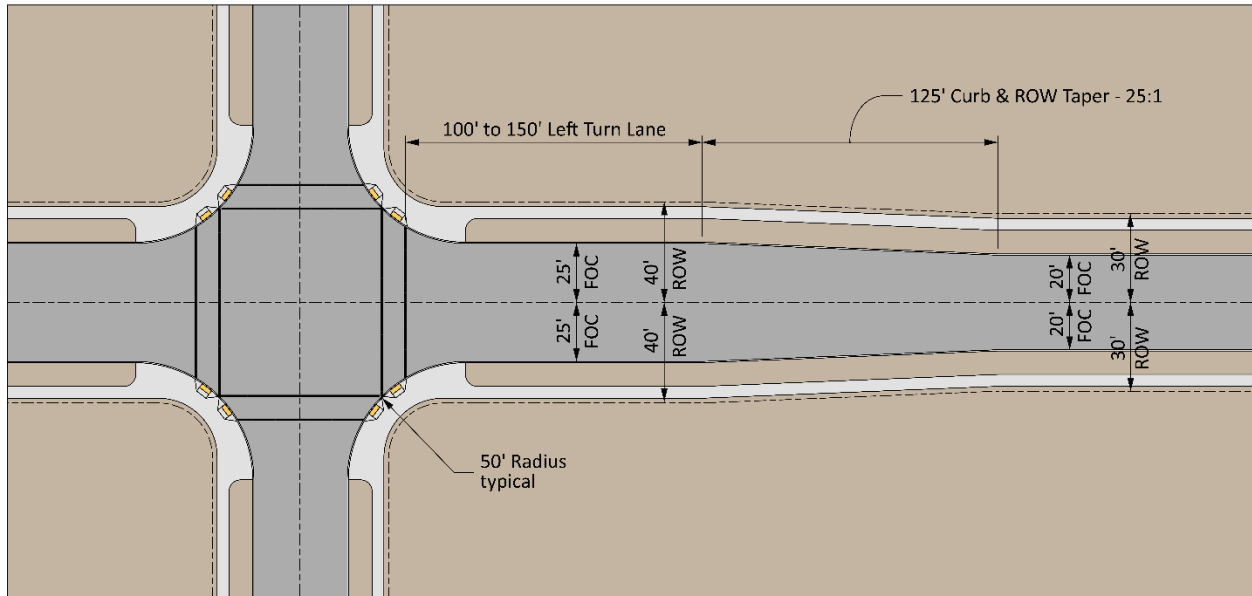

Figure 2.3-14 Intersection Flares, Cross-Section F

### 2.3.7 MEDIANS

Medians shall be provided as identified by street classification and may be permitted on collector and local streets with the approval of the Street Transportation Department and the inclusion of a private maintenance agreement. Raised median islands are intended to separate opposing traffic flows, restrict indiscriminate crossing maneuvers, control turns, and protect vehicles waiting to turn left. The basic purpose of a median island is to expedite traffic and increase vehicle and pedestrian safety. Too frequent openings may void these benefits.

#### Median Widths

The width of a raised median is measured from the face of median curb to the face of median curb. The nominal width of a raised median island is specified in **Table 2.2-1**.

At intersections, when a raised median island is narrowed for a left-turn pocket, the minimum width is 4'. Only in exceptional circumstances will a raised median be approved to a width of less than 4'.

#### Raised Medians

Raised medians that are more than 4' in width are normally landscaped. Landscaping and other median features shall not restrict the sight distance for vehicles turning left on the through street. Median landscaping shall not restrict sight distance in the vicinity of intersections for side street traffic. Per City of Phoenix Street Landscape Manual, no plant material within 10' of the end of street median islands and no trees planted within 80' of the end of the street median. Street median islands 0 to 800' in length must maintain an open area equal to 30' in length at either end or have turning lane (non-signal) to provide for parking a service vehicle. Street median islands greater than 800' in length must maintain an open area equal to 75' length at the mid-point, and either end or have a turning lane (non-signal) to provide for parking of a service vehicle. A mid-point open area should be provided for each additional 1,000' of median island.

Street median island 4' or less in width to be hardscaped, including stamped concrete. Concrete to be 6" thick, 3000 psi with welded wire reinforcement and stamped brick finish. Coordinate with Street Transportation Department for texture, brick pattern, and color.

Raised medians on collector and local public streets shall be maintained by the Development's Homeowners Association and/or applicable private maintenance agreement with the City of Phoenix.

Where initial development constructed only one-half of the travel way, the development that completes the cross-section is responsible for construction of the median. This construction may extend beyond property frontage to tie to existing constructed medians.

### Median Nose Islands

A median island nose of 4' to 5' in width should be paved. The paved surface should have the same cross-slope as the street pavement. Acceptable paving material is Portland concrete cement. The median island nose shall be constructed per City of Phoenix Standard Details for Construction.

### Spacing and Location of Median Openings

See **Chapter 6, Access Management**, for median opening criteria.

### Intersection Raised Median Positive Offset

Medians at intersections should be constructed with positive offset. A positive offset of left-turn lanes improves sight distance and reduces risk of left-turn crashes.

At intersection approaches that have straight alignment with no horizontal curves and the roads intersect at or close to 90 degrees, a 2' positive offset provides unrestricted sight distance when the opposing left-turn vehicle is a passenger car, as shown in **Figure 2.3-15**. A 3.5' positive offset provides unrestricted sight distance when the opposing left-turn vehicle is a truck (based on a truck width of 8.5', which corresponds to City Transit Bus, WB-50, and WB-67). These conditions generally apply to existing conditions where retrofit improvements are being made. Use truck offset conditions where 10% or more trucks are present.

When installing left-turn lanes or designing new intersections where left-turning traffic must yield to on-coming traffic, designer shall provide a minimum of 3.5' of positive offset for opposing left-turn lanes, as shown in **Figure 2.3-16** to ensure adequate sight distance for left-turning drivers. When median width is less than 2', the raised median may be terminated at the point where the median narrows to 4'. Striping and raised pavement markers, in accordance with City of Phoenix standards, is then carried through the remainder of the median taper and storage length, as shown in **Figure 2.3-17**.

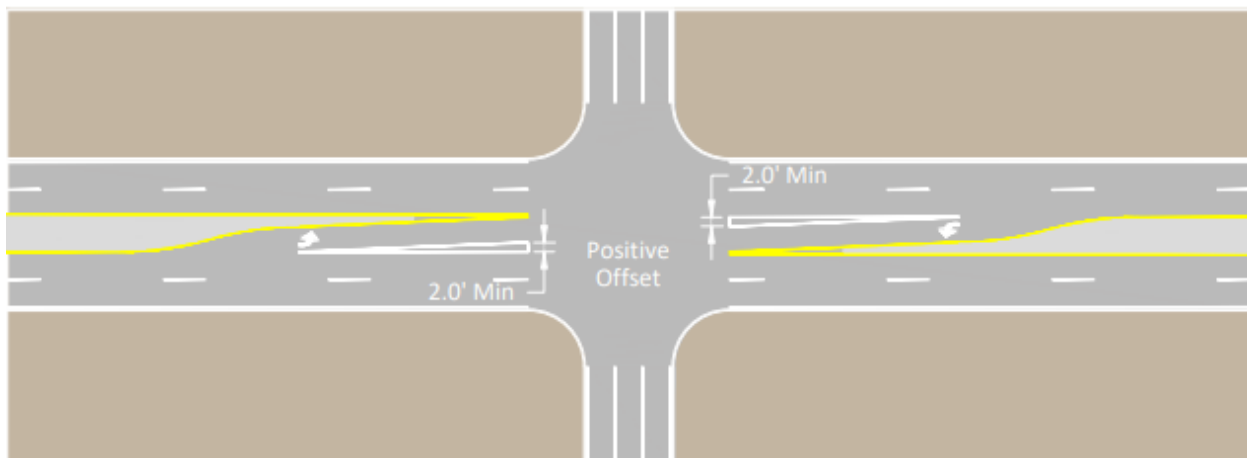

Source: Adapted from MAG Left-Turn Crash Mitigation Implementation Template and Guidance, May 2018, p. 3

Figure 2.3-15 Positive Offset for Left-Turn Lanes

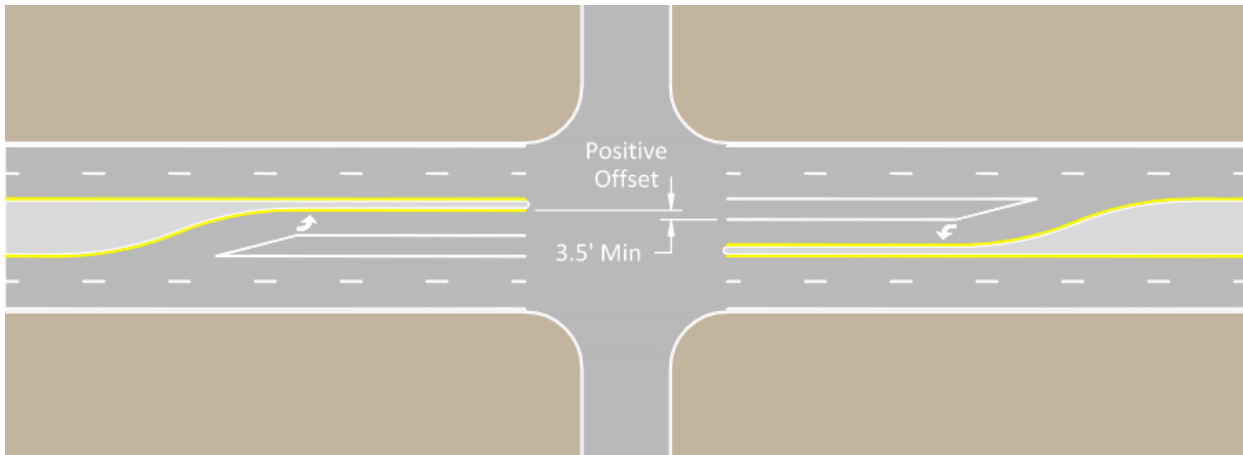

Source: Adapted from MAG Left-Turn Crash Mitigation Implementation Template and Guidance, May 2018, p. 3

Figure 2.3-16 Minimum Positive Offset for New Left-Turn Lanes

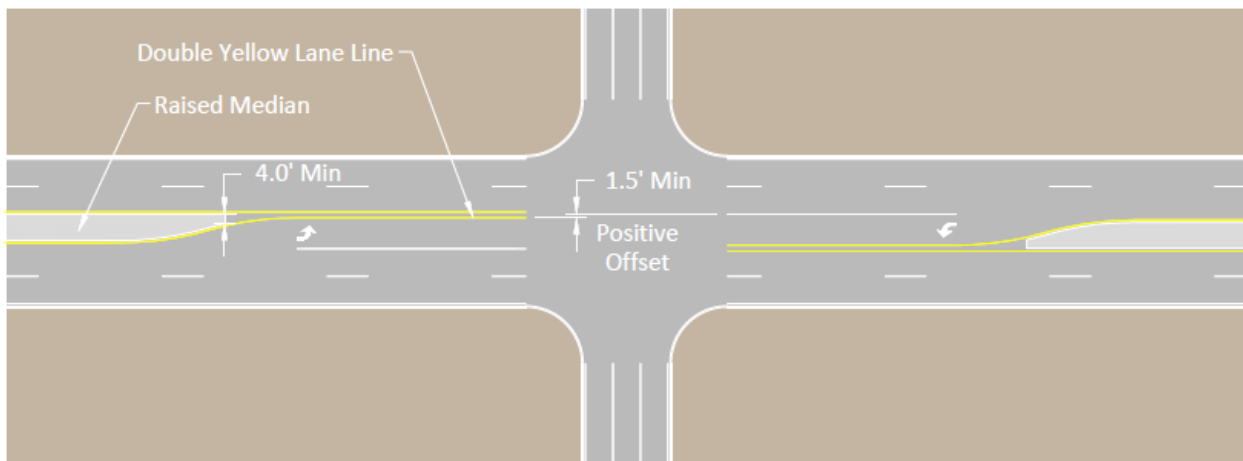

Figure 2.3-17 Truncated Raised Median to Striping for New Left-Turn Lanes

## 2.3.8 CURB TYPE

### Vertical Curbs

Vertical curbs (6" typical) are required for all streets except local single-family residential streets, where traffic calming is not being implemented. Vertical curb is required on collector streets. New subdivisions must be platted accordingly to accommodate vertical curb. For new development within in-fill areas, front-facing single-family homes will need to be wing-type driveways when on collector designated streets.

Vertical curb shall be used through the curb return from the Point of Curve (PC) to the Point of Tangent (PT) regardless of whether the tangent curb sections are vertical, ribbon or roll curb. All curb returns shall be provided with curb ramps with sidewalk from PC to PT per the applicable City of Phoenix sidewalk ramp detail as required by the Americans with Disabilities Act (ADA).

Local single-family residential streets with special narrower cross-sections will be constructed with vertical curbs and offset (separated) sidewalks. Vertical curbs should also be used where drainage considerations make such use desirable. Vertical curbs with gutter are to be constructed in accordance with the current City of Phoenix supplements to the MAG (Maricopa Association of Governments) standard details.

Vertical curb and gutter type shall match the adjacent pavement slope to the gutter cross slope direction. The curb height shown on the standard detail is 6", but the following variations may be used where appropriate:

- Where fire lane or public maintenance vehicle access to abutting property must be provided over the curb, use mountable curb and gutter.

### Ribbon Curb

Ribbon curb is permitted as specified by the City of Phoenix Zoning Ordinance, Section 32-35.C Option 2.2. Local residential streets may be paved with ribbon curbs if drainage and pedestrian traffic permit; all collector streets are to have vertical curbs and sidewalks. Ribbon curbs may be provided if the sidewalk is set back a minimum of 5' from the curb. Ribbon curb is discouraged but may be used in lieu of roll curb for local residential streets, where attached sidewalks are not provided. When ribbon curb is used, drainage runoff from the road shall not drain with the road but shall be directed to roadside drainage ditches.

### Roll Curb

Roll curb is permitted on local single-family residential streets except where vertical curb is required for drainage and is to be constructed in accordance with the current City of Phoenix supplements to the MAG Standard Details.

## 2.3.9 HORIZONTAL ALIGNMENT

AASHTO A Policy on Geometric Design of Highways and Streets specifies design criteria and guidelines for horizontal curves. The City of Phoenix also requires:

### Tangent Sections Between Reverse Curves

- On arterial and collector streets a tangent section must be provided between two curves that curve in the opposite direction. AASHTO requires that a tangent be provided between reverse curves long enough to satisfy superelevation transitions. For urban roadways without superelevation, a minimum tangent length of 100' is desired between reverse curves. Generally abrupt reversals in alignment should be avoided.

### Tangent Sections Approaching Intersections

- Tangent sections must be provided between an intersection and a curve on collector and arterial streets. The tangent section should be designed to satisfy AASHTO's criteria for intersection sight distance.

### Tangent Sections Between Curves in the Same Direction

- If super-elevation is provided in the curved portions of the roadway, tangent lengths will be determined by the super-elevation transition lengths indicated in AASHTO A Policy on Geometric Design of Highways and Streets.

## 2.3.10 VERTICAL ALIGNMENT

### Longitudinal Grades

Longitudinal grades should follow the guidelines:

- **Arterial streets.** As determined by the Street Transportation Director.

- **Collector streets.** Maximum of seven percent.
- **Local streets.** Maximum of nine percent.
- **All streets:** Minimum of 0.4 percent; grades less than 0.4 percent to 0.15 percent require written approval from Street Transportation Department.

### Cross Slopes

Cross slopes should follow the guidelines:

- Streets with concrete gutters:
  - ▶ Cross-slope desirable: 2 percent.
  - ▶ Cross-slope maximum: 3 percent
  - ▶ Cross-slope minimum: 1 percent, with a gutter slope minimum of 0.3 percent.

Where rigid adherence to these standards causes unreasonable or unwarranted hardship in design or cost without commensurate public benefit, exceptions may be made by the Street Transportation Department upon review and approval of the Street Maintenance Deputy Director in the Street Transportation Department.

### Vertical Curves

*AASHTO A Policy on Geometric Design of Highways and Streets* specifies design criteria and guidelines for vertical curves. Vertical curves shall be designed to provide adequate sight distance, safety, comfortable driving, good drainage, and a pleasant appearance.

Algebraic difference in grades without a vertical curve on continuous roadways shall be equal to or less than the values specified for the following conditions:

- 0.2% Federal Aid Projects (applies to National Highway System roads)
- 0.3% Equal to or greater than 55 mph design speed
- 0.5% Equal to or greater than, 40 mph, but less than 55 mph design speed
- 1.0% Less than 40 mph design speed
- 2.0% Local residential street

### Minimum Vertical Curve Lengths

Vertical curve should be in compliance with City Ordinance 32-27C. A parabolic vertical curve is to be used. *AASHTO A Policy on Geometric Design of Highways and Streets* provides all necessary mathematical relations for computing a vertical curve for both crests and sags. Minimum vertical-curve lengths are determined by sight distance requirements for a given design speed.

### Crest Vertical Curve Lengths

Minimum crest curve lengths are determined by either the stopping sight distance or the passing sight distance, whichever provides the greatest curve length, unless the street is striped for no passing.

- The minimum crest vertical curve lengths on streets with two or more through travel lanes per direction must only meet stopping sight distance requirements.
- Two-Lane Streets – Passing sight distance requirements should be met on streets with one through travel lane per direction. When crest curve construction in accordance with passing sight distance



requirements would result in the creation of drainage problems or excessive cuts or fills, the curve length may be reduced with the installation of appropriate traffic control measures.

iii) Minimum Crest Vertical Curve Length Determined by Stopping Sight Distance – The following equations are to be used to determine the minimum crest vertical curve lengths based upon stopping distance requirements (assumes AASHTO minimum requirements of 3.5' driver height and a 2.0' object height):

$$\text{When } S_s < L, L = \frac{AS_s^2}{2158}$$

$$\text{When } S_s > L, L = 2S_s - \frac{2158}{A}$$

Where:

$S_s$  = Stopping sight distance in feet for a given design speed

L = Length of curve in feet

A = Algebraic grade difference in percent

iv) Minimum Crest Vertical Curve Length Determined by Passing Sight Distance – The following equations are to be used to determine the minimum crest vertical curve lengths based upon sight distance requirements (assumes AASHTO minimum requirements of 3.5' driver height and a 2.0' object height):

$$\text{When } S_p < L, L = \frac{AS_p^2}{2800}$$

$$\text{When } S_p > L, L = 2S_p - \frac{2800}{A}$$

Where:

$S_p$  = Passing sight distance in feet for a given design speed

L = Length of curve in feet

A = Algebraic grade difference in percent

### Sag Vertical Curve Lengths

Minimum sag vertical curve lengths are determined by either the stopping sight distance or comfort factors. The longer of the two possible minimum curve lengths will be used.

i) Minimum Sag Vertical Curve Length Determined by Stopping Sight Distance – The following equations are to be used to determine the minimum sag vertical curve length based upon stopping sight distance requirements (assuming AASHTO minimum requirements of two ft headlight height and a 1° divergence):

$$\text{When } S_s < L, L = \frac{A \times S_s^2}{400 + 3.5 \times S_s}$$

$$\text{When } S_s > L, L = 2 \times S_s - \frac{400 + 3.5 \times S_s}{A}$$

Where:

$S_s$  = Stopping sight distance in feet for a given design speed

L = Length of curve in feet

A = Algebraic grade difference in percent

ii) Minimum Sag Vertical Curve Length Determined by Comfort – The following equation is to be used to determine the minimum sag vertical curve length based upon comfort:

$$L = \frac{A \times V^2}{46.5}$$

- L = Length of curve in feet
- A = Algebraic grade difference in percent
- V = Design speed in mph

**Combined Horizontal and Vertical Curves**

Where horizontal and vertical curves are required, care should be taken to understand resulting alignment for sight distance and visual perception. Sharp horizontal curves should not be introduced at or near the top of significant crest vertical curves where sight distance may be limited. Horizontal curves near the bottom of short sag vertical curves appear foreshortened and influence driving. Where horizontal and vertical curves are combined, the horizontal curve lengths should lead (i.e., be made longer) than the vertical curve. Refer to AASHTO A Policy on Geometric Design of Highways and Streets.

**2.3.11 ALIGNMENT SIGHT DISTANCE**

Stopping sight distance is the minimum sight distance to be provided at all points on streets. Stopping sight distance is that required for a vehicle traveling at the design speed to bring the vehicle to a stop after an object on the road becomes visible under worst case (wet pavement, slow-driver reaction) conditions.

Stopping sight distance shall also be provided in the vicinity of intersections. Sight distance is measured from the driver’s eye, 3.5’ above the pavement to the top of an object on the pavement 2.0’ high for stopping sight distance.

Minimum stopping sight distances is consistent with AASHTO A Policy on Geometric Design of Highways and Streets, shown in **Table 2.3-3** Stopping Sight Distance on Level Roadways. These distances vary with design speed.

City of Phoenix does not designate passing zones on City of Phoenix streets.

*Table 2.3-3 Stopping Sight Distance on Level Roadways*

<b>Design Speed (mph)</b>	25	30	35	40	45	50	55
<b>Stopping Sight Distance (ft)</b>	155	200	250	305	360	425	495

*Source: AASHTO Green Book, 2018, Tables 3-1*

**Superelevation**

Superelevation is not used on downtown and urban roadways. Superelevation is discouraged on suburban, rural, and industrial roadways. Superelevation may only be used when other means of design is not feasible. All superelevation will be reviewed by the Street Transportation Department. When superelevation is used, the following criteria shall be followed:

**Superelevation 0.02 ft/ft (2%)**

Superelevation of 0.02 ft/ft may be used when the standard radius cannot be provided due to circumstances beyond the control of the engineer and the general alignment cannot be changed.

**Superelevation Greater than 0.02 ft/ft (2%)**

Superelevation greater than 0.02 ft/ft may not be used except when approved by the Street Transportation Department. In no case shall a superelevation exceed 0.04 ft/ft.

Transition for superelevation is consistent with AASHTO A Policy on Geometric Design of Highways and Streets. A 1% minimum slope is required in at least one direction for drainage purposes.

**2.4 FLEX ZONE**

The flex zone is the part of the right-of-way adjacent to an existing curb face that can be used for multiple purposes such as bicycle facilities, transit stops, parking, delivery zones, and drop off zones. The flex zone in relation to other right-of-way zones is depicted in **Figure 2.4-1**.

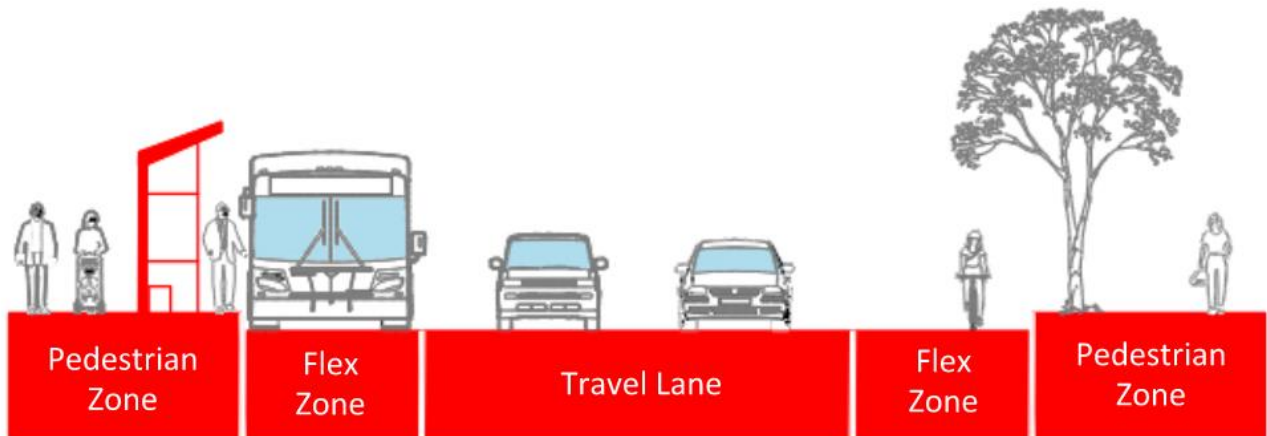

**Source:** Adapted from *Seattle Right-of-Way Improvements Manual, Standard 2.1 Right-of-Way Allocation*

*Figure 2.4-1 Right-of-way Zones*

**2.4.1 BICYCLE FACILITIES**

On-street bike lanes may be used where a minimum of 6' from curb face can be obtained. Where practical, it is desirable to provide 8' from curb face to provide a buffered bicycle lane.

ARS 28-815 prohibits motorized vehicles to park or stop in the bike lane. To recognize the needs of residents along commuter routes on collector/local streets, the bike lane may be signed as in effect for only part of the day and imposing parking restrictions only during commute periods (7:00 a.m. - 6:00 p.m. Monday through Friday).

More information on the design of bicycle facilities is provided in Chapter 8, Bikeways.

**2.4.2 ON-STREET PARKING**

General principles for when parking is desirable or allowed are described in this section.

Local streets and collectors provide for on-street parking to provide access to dwelling units but may be limited by specific ordinances which require a neighborhood parking permit or equivalent or in situations where parking would obstruct access to fire hydrants or cause a safety issue.

In general, parking is accounted for in the design of typical cross sections for local streets and collectors.

Streets in an industrial context should be designed for parking of the WB-67 interstate semi-trailer design vehicle, and parking is included in the typical cross section design for streets in industrial areas.

Arterials should not be designed for parking.

On-street parking may be desirable on collector streets in an urban context where sufficient curb width is available.

### 2.4.3 TRANSIT

Flex zone may include bus stops or bus pullouts/bus bays, boarding-bulb stops, and side-boarding island stops.

#### Transit Stops

##### Transit Stop Placement

The preferred location for a bus stop is on the intersection exit (far side) rather than the intersection approach. Near side bus-stop locations are normally less desirable than far-side bus stops, particularly near signalized intersections, because they:

- Block vehicles from turning right on red.
- Force following vehicles to stop even when there is a green signal.
- May partially obstruct motorist's and pedestrian's view of each other at crosswalks.

The Public Transit Department decides if a transit stop is needed to service their patrons and staff reviews operational considerations and determines the optimal location for signs. The following criteria should be considered in selecting bus stop locations:

- At unsignalized intersections, bus stops should normally be far-side and clear of the crosswalk to prevent blocking of pedestrian movements.
- At signalized intersections, bus stops should offer additional clearance from the crosswalk at locations with three through lanes. When only two through lanes exist, the bus stop should be further down the street if there is no bus pullout. For example, on signalized collector streets, the left lane is normally blocked by left turns, leaving only one lane, this means the bus stop should be located sufficiently downstream to not block the only effective through lane.

Design engineers should consult City of Phoenix Standard Details for location and layout design.

#### Bus Bays

Location of bus bays, bus bay shelters and installation and removal of existing bus bays/bus bay shelters are an important design feature and shall be evaluated and approved early in design with Valley Metro, Street Transportation Department, and the Public Transit Department.

Design engineers should reference City of Phoenix Standard Details for bus bay, pad, and shelter design.

## 2.5 PEDESTRIAN ZONE

The pedestrian zone is the portion of a street that is between the flex zone and the edge of right-of-way. It is comprised of the landscape/streetscape/furniture area, the pedestrian clear area, and the frontage area.

**Landscape/Streetscape/Furniture Area** (including the curb) is the area between the roadway curb face and the front edge of the pedestrian-clear zone. This area buffers pedestrians from the adjacent roadway and is the appropriate location for, street trees and vegetation, as well as amenities permitted by revocable permit with the city and includes the 6" curb in its dimensions. It is also the preferred location for other elements, such as signage, pedestrian lighting, hydrants, and above and below grade utilities. Clearance and setback requirements apply to many elements located in the landscape/furniture area.

**Pedestrian Clear Area** is the area of the sidewalk corridor that is specifically reserved for pedestrian travel. As required by City of Phoenix Zoning Ordinance or policy plans, wider clear area widths are required within transit areas and high-pedestrian activity areas street furniture, street trees, planters, and other vertical elements such as poles, fire hydrants and street furniture, as well as temporary signs and other items shall not protrude into the pedestrian clear area. The desirable clear area width is 5'. The clear area width must be compliant with ADA requirements.

**Frontage Area** is the area between the property line and pedestrian clear area. Frontage area can accommodate store entrances outdoor dining, landscaping, or other amenities. A minimum of 2' is recommended for the frontage area to allow for shy distance from fixed objects.

### 2.5.1 SIDEWALKS

Sidewalks shall be provided along all streets unless a specific exemption allows. Exceptions require approval by the Street Transportation Director.

Sidewalks should be constructed a minimum of 5' wide on arterial and collector streets, and 4' wide on local streets, and in no case less than identified on the City-approved Street Classification Map and/or adopted Neighborhood or Area Specific Plans or Ordinance. In areas with high pedestrian volumes, wider sidewalks may be required. Sidewalks shall be constructed consistent with current City of Phoenix standard cross-sections.

Sidewalks shall be designed in accordance with current ADA guidelines. A 5' by 5' passing area must be provided every 200' to allow wheelchairs to pass on all sidewalks less than 5' wide. Driveways and other connecting sidewalks may be used to provide the passing area, as long as the cross-slope meets ADA standards. Poles and fire hydrants may encroach into the pedestrian realm, but the sidewalk must meet current ADA minimum clear widths.

Sidewalks should stay at-grade and level (1.5 percent preferred cross-slope) across driveway openings.

Slopes of pedestrian facilities shall not exceed the maximum grades indicated in ADA: sidewalk cross slope of 2 percent, ramp slope of 8.33 percent, ramp and landing cross slope of 2 percent and flared side (wing) slope of 10 percent. Expansion joints and contraction joints are required to be constructed per the MAG Uniform Standard Specifications for Public Works Construction and Standard Details and the City of Phoenix Supplements to these.

The surface of concrete sidewalk or curb ramp shall not deviate in excess of 1/8” over 5’ as tested with a five-foot straightedge except for the ¼” recess of the preformed material in expansion joints.

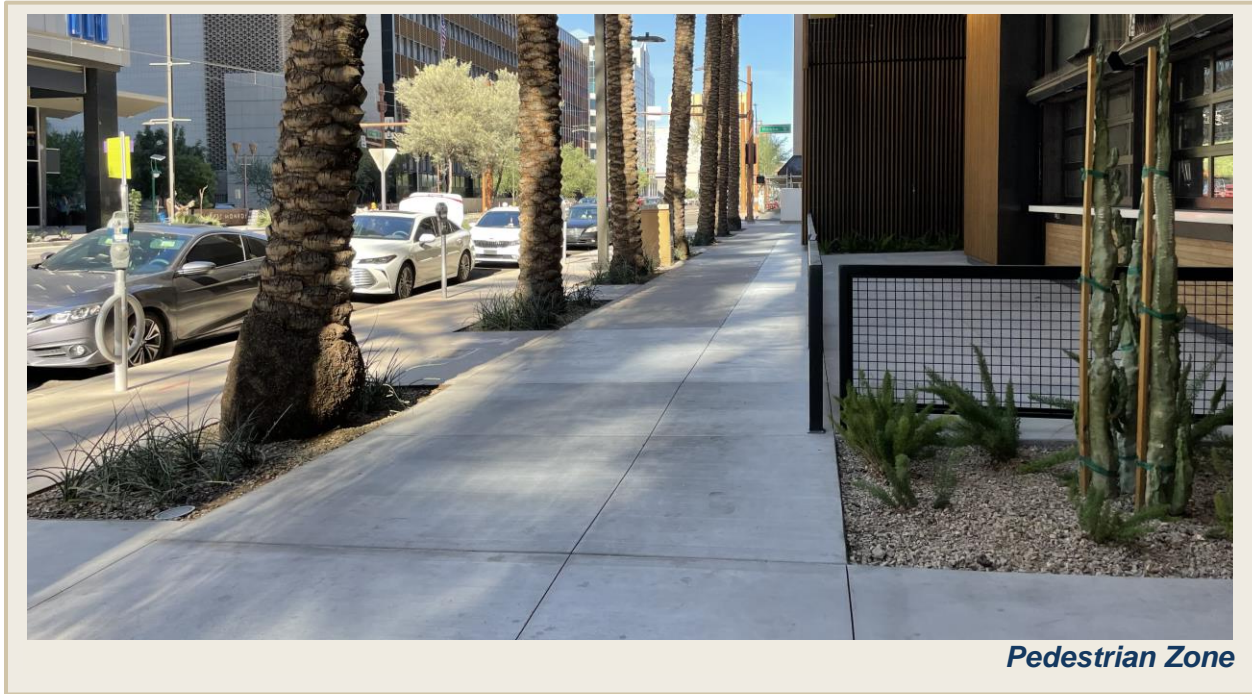

Figure 2.5-1 Pedestrian Zone Example

## 2.6 INTERSECTIONS

### 2.6.1 CURB RETURN RADII

Table 2.6-1 presents curb return radii to accommodate turning movements of vehicles by street typology.

Table 2.6-1 Curb Return Radii

Classification of Intersecting Streets	Curb Return Radii (ft) by Area Type			
	Downtown/Urban	Residential	Suburban	Industrial
Arterial and Arterial	20'	35'	35'	35'
Arterial and Collector	20'	30'	30'	35'
Arterial and Local	20'	25'	25'	35'
Collector and Collector	10' minimum	30'	25'	35'
Collector and Local	10' minimum	20'	20'	35'
Local and Local	10' minimum	20'	20'	35'
Local and Private	10' minimum	20'	20'	35'

### 2.6.2 INTERSECTION SIGHT DISTANCE

Intersection sight distance is the distance a motorist can see approaching vehicles before their line of sight is blocked by an obstruction near the intersection. The driver of a vehicle approaching or departing from a stopped position at an intersection should have an unobstructed view of the intersection, including any traffic control devices, and sufficient lengths along the intersecting roadway to permit the driver to anticipate and avoid potential collisions. Examples of obstructions include crops, hedges, trees,

parked vehicles, utility poles, or buildings. In addition, the horizontal and vertical alignment of the roadway approaching the intersection can reduce the sight triangle of vehicles navigating the intersection. Sight distance must also be provided for left-turning traffic turning from the major road.

The required intersection sight distance is dependent upon the traffic speed and width of the major road. Sight distance triangles should be calculated based on AASHTO A Policy on Geometric Design of Highways and Streets. The design speed shall be 10 mph higher than the speed limit of the major road.

The design must demonstrate that other vehicles, such as opposing left-turn vehicles, do not block sight distance, particularly along curves. Both approach triangles and departure sight triangles must be shown in intersection plans.

Landscaping plans must be consistent with sight visibility requirements. It is the responsibility of the developer to provide landscaping between the property line and the curb consistent with sight visibility triangle requirements. Vegetation within the sight triangle is allowable if it is of a low variety that remains below 24" when mature. Trees may be considered as long as the canopy is above 10' and if it is a single trunk variety and less than 12" in diameter.

Driveways shall not be placed where it creates a sight visibility issue with existing large diameter power poles, landscaping, and other obstructions. Conflicts should be resolved through utility relocation or by demonstrating through a sight distance analysis performed by a registered traffic engineer in conformance with AASHTO guidelines.

### Approach Sight Triangles

Approach sight triangles demonstrates that drivers have sufficient time to react to vehicles on uncontrolled or yield-controlled intersecting cross streets. According to *AASHTO A Policy on Geometric Design of Highways and Streets*, "Each quadrant of an intersection should contain a triangular area free of obstructions that might block an approaching driver's view of potentially conflicting vehicles. The length of the legs of this triangular area, along both intersecting roadways, should be such that the driver can see any potentially conflicting vehicles in sufficient time to slow or stop before colliding within the intersection." Approach sight triangles are illustrated in **Table 2.6-2** and **Figure 2.6-1**.

### Departure Sight Triangles

*AASHTO A Policy on Geometric Design of Highways and Streets*, states "A second type of clear-sight triangle (departure sight triangle) provides sight distance sufficient for a stopped driver on a minor-road approach to depart from the intersection and enter or cross the major road." Departure sight triangles are illustrated in **Table 2.6-3** and **Figure 2.6-2**.

### Alignment and Profile

Intersections occurring on horizontal, or crest vertical curves are undesirable. When there is latitude in the selection of intersection locations, vertical or horizontal curvature should be avoided. An alignment or grade change is frequently warranted when major intersections are involved. If a curve is unavoidable, it should be as flat as site conditions permit. Where the grade of the through roadway is steep, flattening through the intersection is desirable as a safety and efficiency measure. Grade breaks through major-major, major-collector, and any other signalized or potentially signalized intersections shall not exceed 2.5 percent desirable or 3.0 percent absolute maximum. Sight triangles on horizontal curves are illustrated in **Table 2.6-4** and **Figure 2.6-3**.

Table 2.6-2 Required Sight Distance, Left Turn from Major Road

City of Phoenix Street Cross-Section	A	B	C, CM, D	E
Through Road Pavement Width	104'	94'	64', 74'	50'
Time Gap (sec)	8.25	7.75	7.25	6.5
Design Speed				
30 mph	364'	342'	320'	287'
35 mph	424'	399'	373'	334'
40 mph	485'	456'	426'	382'
45 mph	546'	513'	480'	430'
50 mph	606'	570'	533'	478'

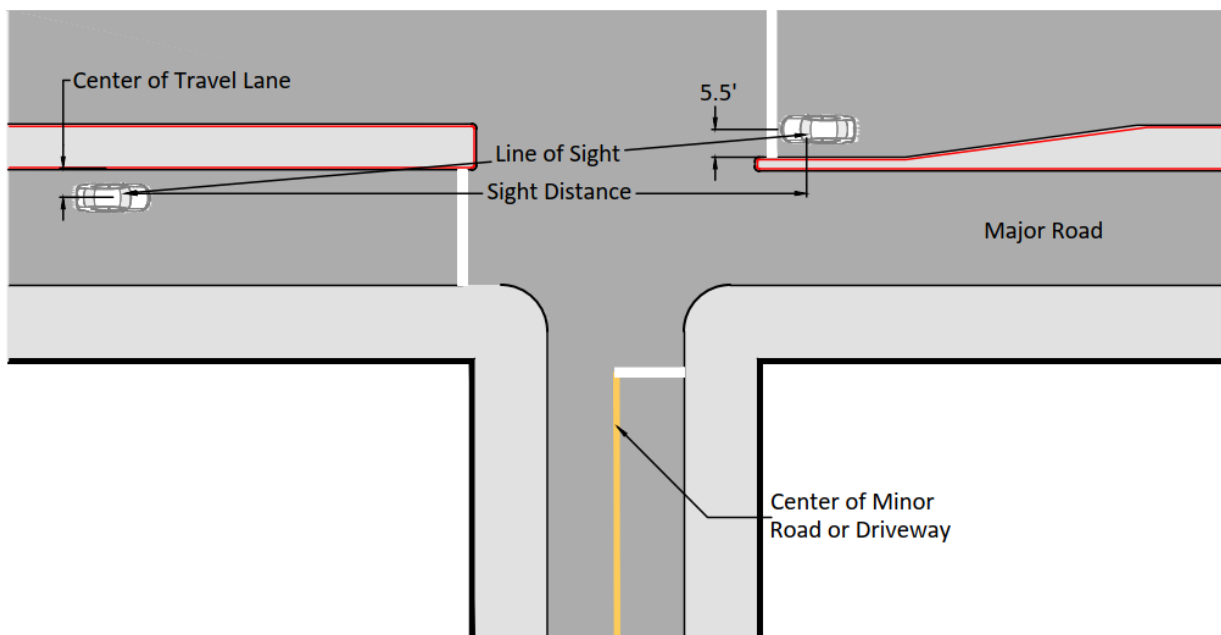

\*Passenger car, at-grade/level; adjustments required for trucks and grades

Figure 2.6-1 Sight Triangles, Left-Turn from Major Road



Table 2.6-3 Sight Distance (feet), Left-Turn from Stop

City of Phoenix Street Cross-Section	A	B	C, CM, D	E	F (Industrial)	F (Residential), FN, G, H, I
Through Road Pavement Width	104'	94'	64', 74'	50'	50'	36'
Time Gap (sec)	9.75 sec	9.5 sec	8.75 sec	8.5 sec	8 sec	7.75 sec
Design Speed						
30 mph	430'	419'	386'	375'	353'	342'
35 mph	502'	489'	450'	437'	412'	399'
40 mph	573'	559'	515'	500'	470'	N/A
45 mph	645'	628'	579'	562'	529'	N/A
50 mph	717'	698'	643'	N/A	N/A	N/A

Values are provided for guidance only based on passenger car equivalent and minor road approach grades of 3 percent or less; professional engineer should verify site-specific conditions including vehicle type, grades, and pavement widths

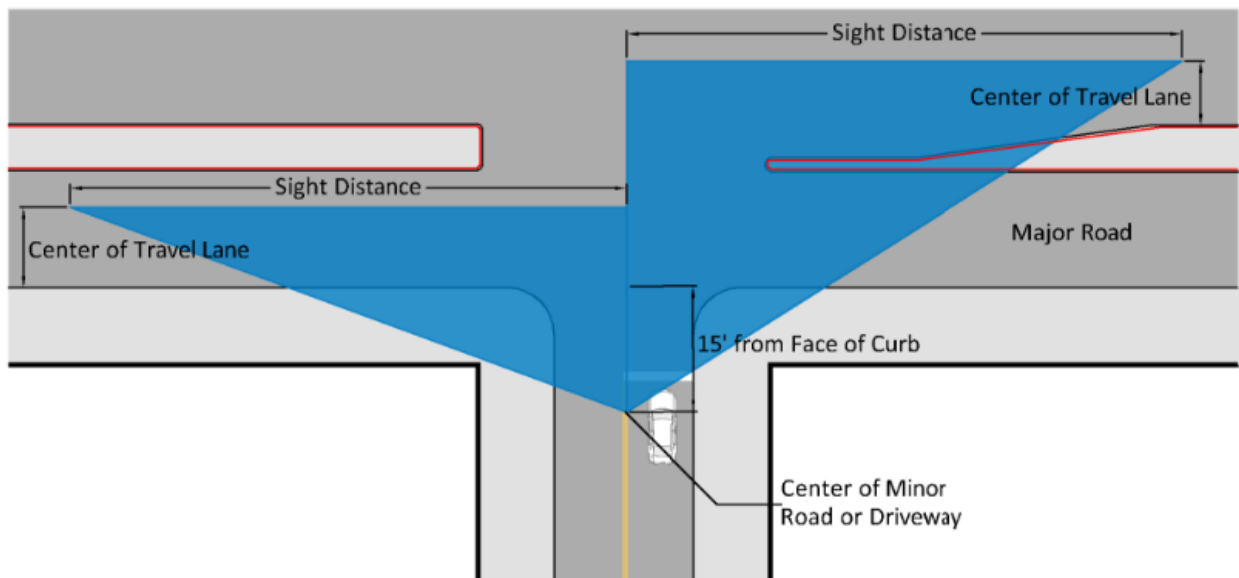

Figure 2.6-2 Sight Triangles, Left-Turn from Stop

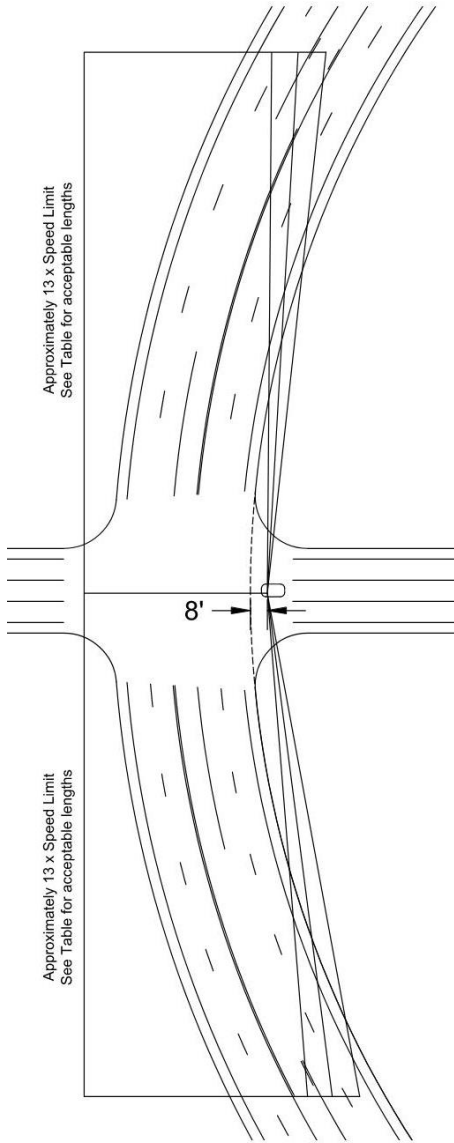

Figure 2.6-3 Sight Triangles, Horizontal Curve

Table 2.6-4 Sight Distance, Horizontal Curve

<b>3-Lane Streets</b> <i>(Bike Lane, Thru, Left, Thru, Bike Lane) or Smaller</i>			
Speed	Length Passenger Vehicle	Length Single Unit Truck	Acceptable Average
25 mph	280'	350'	315'
30 mph	335'	420'	380'
35 mph	390'	490'	440'
<b>5-Lane Streets</b> <i>(Bike Lane, Two Thru, Left, Two Thru, Bike Lane)</i>			
Speed	Length Passenger Vehicle	Length Single Unit Truck	Acceptable Average
25 mph	295'	375'	335'
30 mph	353'	450'	402'
35 mph	412'	525'	469'
40 mph	471'	600'	536'
45 mph	530'	675'	603'
50 mph	588'	750'	670'
<b>6-Lane Streets</b> <i>(Bike Lane, Three Thru, Left, Three Thru, Bike Lane)</i>			
Speed	Length Passenger Vehicle	Length Single Unit Truck	Acceptable Average
25 mph	315'	400'	358'
30 mph	380'	481'	431'
35 mph	438'	561'	500'
40 mph	500'	641'	571'
45 mph	563'	721'	642'
50 mph	625'	801'	713'

### 2.6.3 VISIBILITY FOR TRAFFIC CONTROL DEVICES

#### Stop Signs

All stop signs shall be fully visible to approaching traffic from a distance no less than the stopping sight distance. Design speed is 5 mph over the speed limit.

Stopping sight distance triangles for approaches controlled by stop signs are shown on **Figure 2.6-4**. There shall be no fence, wall, shrubbery, tree, or any other obstruction to vision between a height of 2.5' and 10' above the sidewalk within the stopping sight distance triangle approaching a stop sign.

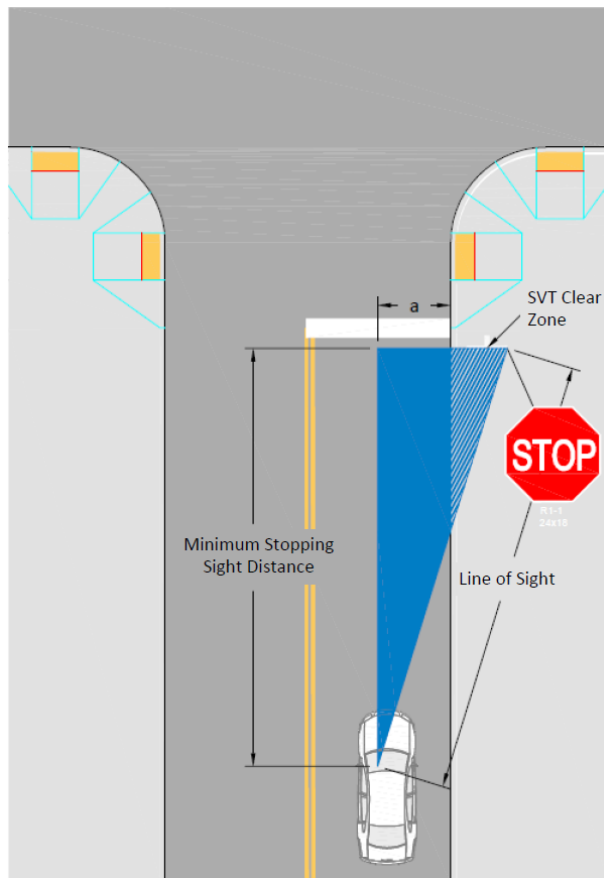

Figure 2.6-4 Sight Triangles Approaching STOP Signs

Table 2.6-5 Stopping Sight Distance, Approaching Stop Signs

Speed Limit of Street Approaching STOP Sign (mph)	Minimum Stopping Sight Distance (feet)
25	200'
30	250'
35	305'
40	360'
45	425'
50	495'

'a' = eye location, approximately measured from center of outside travel lane; lateral location of sign is defined by MUTCD Figure 2A-2.

#### Traffic Signals

Visibility of traffic signal indications shall be maintained per Section 4D.12 of the current *Manual on Uniform Traffic Control Devices (MUTCD)*.

### 2.7 INTERSECTION CONTROL EVALUATION

As described by FHWA<sup>2</sup>, Intersection Control Evaluation (ICE) is a data-driven, performance-based framework and approach used to objectively screen alternatives and identify an optimal geometric and

<sup>2</sup> <https://safety.fhwa.dot.gov/intersection/ice/fhwasa18076.pdf>

control solution for an intersection. ICE is recommended for new intersections or when considering any substantive changes to the traffic control or geometry of existing intersections. Substantive changes are often considered for the following reasons:

- Safety improvement
- Congestion mitigation
- Broader corridor improvement/widening
- Multimodal facility enhancement
- Change of access to an adjacent parcel of land or land development

City of Phoenix encourages an ICE evaluation when considering the following intersection improvements:

- Roundabout
- Displaced Left-Turn/Continuous Flow Intersection
- Median U-turn/Indirect Left-Turn/Thru-Turn/Michigan Left-Turn
- Signalized or Unsignalized Restricted Crossing U-Turn Intersection Jug Handle Intersection/Quadrant Intersection

ICE is typically conducted in two scoping stages as described below.

### **2.7.1 SCOPING**

The purpose of the scoping phase of ICE is to determine, from dozens of potential alternatives, which intersection type and control solutions merit further consideration for the project. The scoping phase of ICE occurs early in project development, helping to inform a project scope and develop a cost estimate and schedule. The purpose of Stage I is to assess the alternatives individually to determine if and to what extent they potentially meet project purpose and need, strategic program goals, project context, and funding constraints. The Stage I scoping analysis involves a combination of quantitative and qualitative performance metrics:

- Does the alternative meet the transportation purpose and need?
- Does the alternative address the key system performance criteria (e.g., safety, non-motorized user accommodation, operational quality, etc.)?
- Does the alternative meet the needs and values of the local community and directly affected stakeholders?

The scoping analysis includes and assessment of safety benefits, operational analysis, and multimodal considerations.

### **2.7.2 Alternative Selection**

Stage II Alternative Selection is intended to differentiate among the intersection alternatives brought forward from the Stage I screening analysis. Stage II analysis is conducted as part of preliminary engineering and includes the estimating of environmental, utility, and right-of-way impacts. The analysis

occurs at a level of detail that allows objective comparisons of alternatives to each other. Stage II evaluates each viable alternative based on the following aspects:

- Safety performance (motorized and non-motorized)
- Operational performance (present vs. projected, peak vs. off-peak)
- Cost
- Benefit-cost
- Environmental, utility, and right-of-way impacts
- Multimodal accommodations (pedestrian, bike, and transit)
- Public opinion and input
- Context (consistency with future land use, transportation plans for the surrounding area)

## 2.8 ROUNDABOUTS

Roundabouts are circular intersections with design and traffic control features including yield control of all entering traffic, channelized approaches, and geometric curvature to ensure that travel speeds on the circulatory roadway are typically less than 30 mph. Roundabouts provide fewer conflict points, lower speeds, and easier decision points than intersections controlled by stop signs or traffic signals.

Roundabouts can offer advantages that conventional intersections (signalized or unsignalized) do not. Benefits can include enhanced safety and operational efficiency (capacity). Safety improvements at roundabouts may be realized due to fewer vehicle conflict points and reduced speeds. From an operations perspective, roundabouts typically function with lower vehicle delays as compared to other intersection forms and control types.

The City of Phoenix generally adheres to *Roundabouts: An Informational Guide*, U.S. Department of Transportation, Federal Highway Administration for development and design of roundabouts.<sup>3</sup>

For guidance regarding traffic circles for traffic-calming purposes, see Chapter 6 of this manual.

### 2.8.1 Roundabout Considerations

A majority of roundabouts within the City of Phoenix are at intersections of local/local, local/collector or collector/collector streets. All roundabouts on arterial and collector streets must be approved by the Street Transportation Department.

Locations recommended for roundabout design should be evaluated based on many factors including:

- At intersections where stop-control causes unnecessary delay
- At intersections with a high left-turn percentage from one or more intersection approaches
- Where a disproportionately high number of crashes involve crossing or turning traffic, resulting in head-on and right-angle crashes

<sup>3</sup> <https://www.fhwa.dot.gov/publications/research/safety/00067/00067.pdf>

- Where it is not desirable to give priority to either roadway
- At intersections with unusual geometry

Roundabouts are NOT typically recommended for the following intersection conditions, but MAY be considered with City approval:

- At the intersection of a collector/arterial where any leg is posted 45 mph or higher
- Where the grade for any intersection leg exceeds 4 percent
- Where traffic volumes are unbalanced with higher flows on one or more intersection approaches
- Where a collector/arterial intersects with a local street and a roundabout would result in unacceptable delays to the collector/arterial street
- Where there is high pedestrian activity including special needs pedestrians
- Where there is inadequate sight distance
- Where there is a large volume of bicycle traffic
- Where a downstream traffic control device such as a traffic signal would result in a queue that extends into the roundabout

Locations where roundabouts are not recommended include intersections:

- Where a satisfactory design cannot be provided
- Where reversible lanes are required
- At a single intersection in a network of linked traffic signals
- Where a signal interconnect system provides a better level-of-service
- Where it is desirable to adjust traffic movements via signal timing

For operational and design purposes, roundabouts have several unique features and dimensions that must be considered.

City of Phoenix Street Transportation Department recommends following *Roundabouts: An Informational Guide*, U.S. Department of Transportation, Federal Highway Administration, for development and design of roundabouts. **Figure 2.8-1** illustrates these elements.

FHWA describes the inscribed circle diameter as the basic parameter in roundabout design. The inscribed circle diameter is the distance across the circle inscribed by the outer curb (or edge) of the circulatory roadway. It is the sum of the central island diameter (which includes the apron) and twice the circulatory roadway. The inscribed circle diameter is determined by multiple design objectives, which must be optimized for a given location. At single-lane roundabouts, the size of the inscribed circle is largely dependent upon the turning requirements of the design vehicle. At double-lane roundabouts, the size of the roundabout is usually determined either by the need to achieve deflection or by the need to fit the entries and exits around the circumference with reasonable entry and exit radii between them.

Generally, the inscribed circle diameter of a double-lane roundabout should be a minimum of 45 mph (150').

City of Phoenix recommends that bicycle ramps be considered within the design, as illustrated in **Figure 2.8-1**.

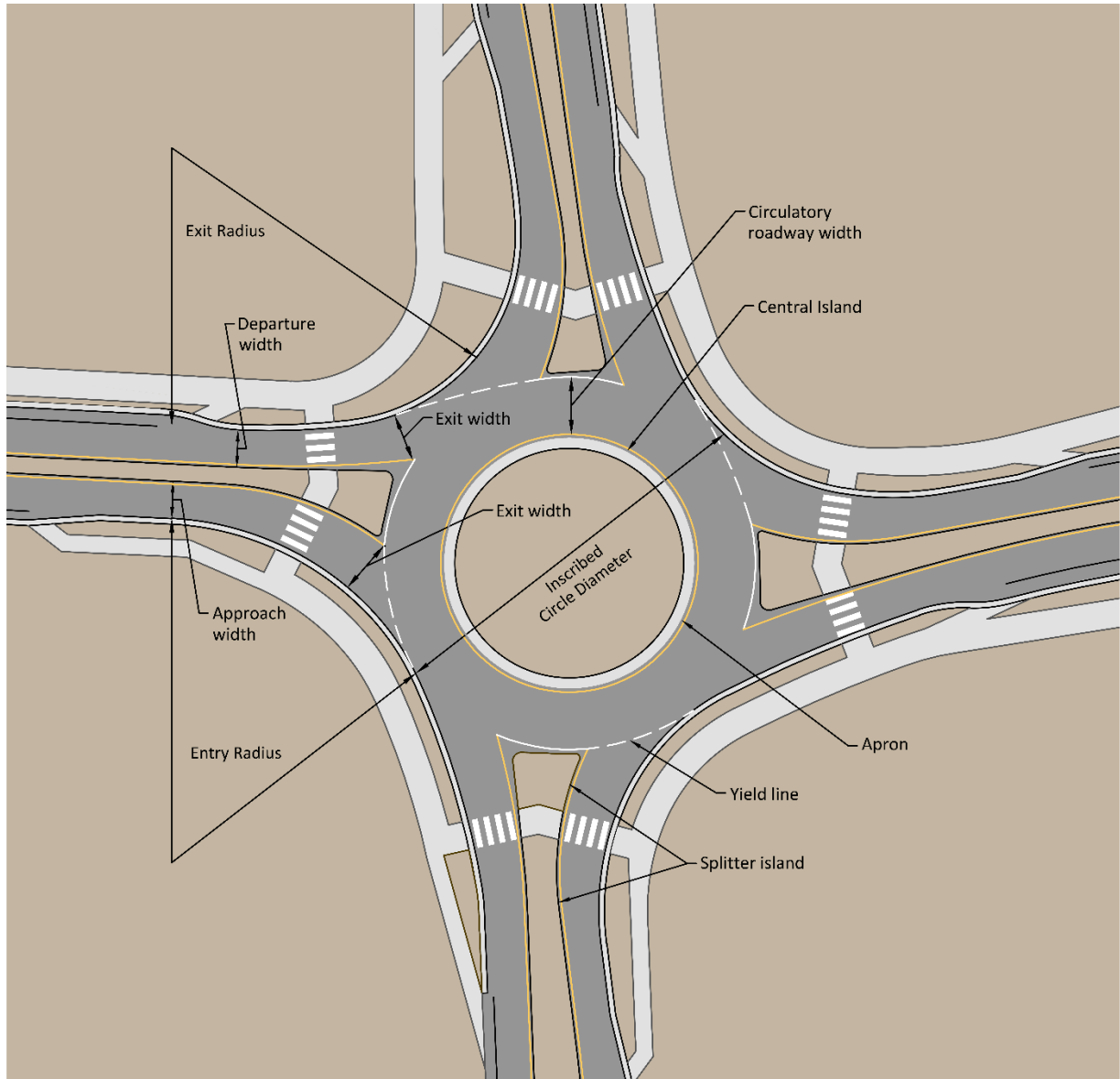

**Source:** Adapted from *Roundabouts: An Informational Guide, Chapter 6, Geometric Design, FHWA*

Figure 2.8-1 Key Roundabout Dimensions (Source: *Roundabouts: An Informational Guide*)

### 2.8.2 Traffic Volumes

Single-lane roundabouts can generally accommodate up to 25,000 veh/day (4-leg conditions) while double-lane roundabouts can service approximately 50,000 veh/day. To confirm effectiveness, roundabout traffic operations are to be evaluated in accordance with *Highway Capacity Manual* procedures. A variety of software tools are available for these purposes. **Table 2.8-1** provides preliminary guidance on capacity of a roundabout considering traffic volumes, number of lanes, and the

percentage of left-turn traffic. The table shows that AADT may be used to predict the possible number of circulating lanes required for planning-level consideration.

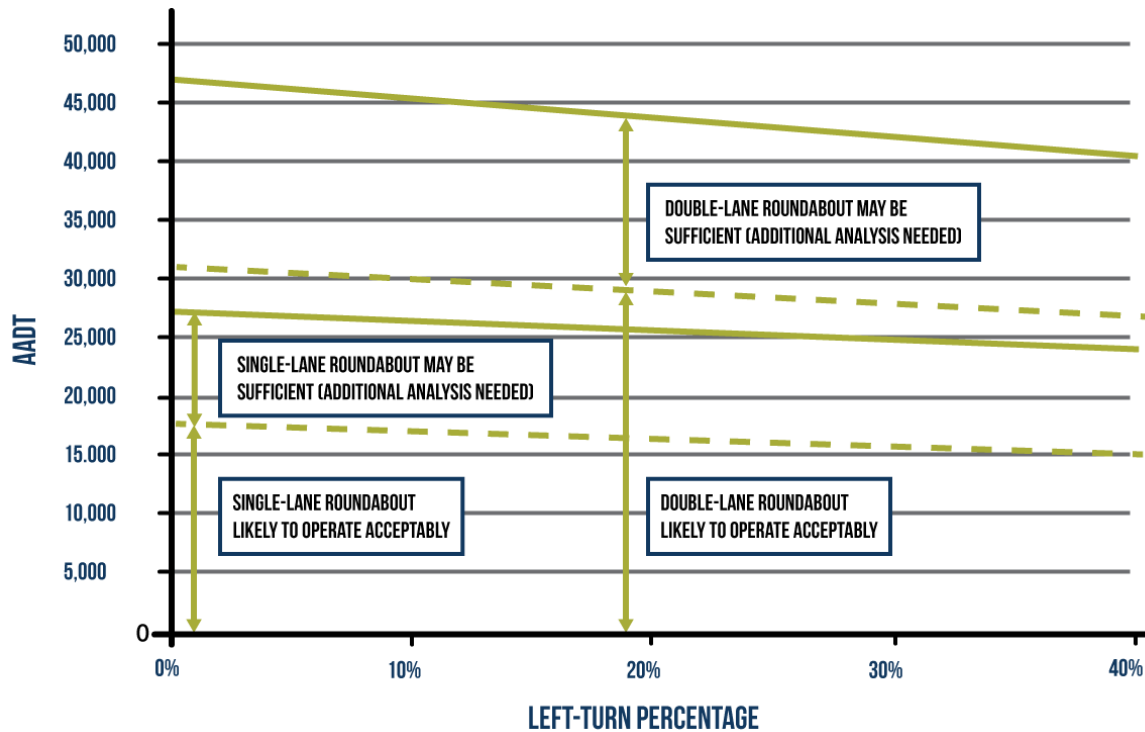

Table 2.8-1 Roundabout Planning-Level Daily Intersection Traffic Volumes (Source: Roundabouts: An Informational Guide)

### 2.8.3 Design Submittal and Review Requirements

All roundabout design submittals submitted to the City of Phoenix will need to include:

- Roundabout layout (including, but not limited to, the inscribed circle diameter, splitter islands, entry width, circulatory roadway, central island, entry and exit radius, and truck apron)
- Capacity Analysis
- Design Vehicle Accommodations and Tracking
- Fastest Path Review Documentation
- Sight Distance Review (stopping sight distance and intersection sight distance)
- Drainage
- Landscaping

Additionally, accommodations for pedestrians and bicyclists are to be appropriately designed.



## 2.9 SPECIAL CONSIDERATIONS

### 2.9.1 Construction of Half-Streets

Local half-street construction is avoided as per City Ordinance, Section 32 – 26 (k), which states “Half-streets at subdivision boundaries should be discouraged except where necessary for continuation of existing patterns. Where a platted half-street abutting the tract to be subdivided exists, and said half-street furnishes the sole access to residential lots, the remaining half shall be platted within the tract.”

#### Design of Cross-Section for Half-Streets

##### Local and Collector Streets

If a half-street must be constructed, a minimum of 24’ of pavement shall be provided for local and collector streets. In the event that right-of-way is not available, and the developer is unable to obtain the additional right-of-way necessary to construct 24’ of pavement, a minimum of 18’ of paving for local streets or 20’ for collector streets, shall be provided. Half-street construction should provide adequate transitions and full-depth asphalt tapers to the adjoining roadways.

##### Arterial Streets

Arterial half-street construction shall provide a minimum of ½ of the approved cross-section of the street, as per the Street Classification Map.

#### Design of Half-Street to Join Existing Street Pavement

The half-street shall be designed to match existing construction unless doing so is likely to create an unsatisfactory condition. If changes are needed to correct conditions on an existing half-street to properly construct the other half of the street, the solutions must be developed with Planning and Development Department, and/or Street Transportation Department staff. Plans for the new half-street must contain sufficient information on the profile and cross-sections of the existing street to demonstrate that the new construction shall match the old construction and result in a full street with a proper cross-section. Tapers are not limited to the frontage of the subject parcel and should extend beyond the subject parcel to the maximum extent consistent with available right-of-way.

#### Design of Half-Street at Intersections

Collector and arterial half-streets must be flared at all arterial street intersections to provide one lane in each direction and a left-turn lane. The inbound lane on a half street, at an arterial or collector street intersection should be a minimum of 18’ in width. The outbound lane should be a minimum of 12’ wide. Additional consideration must be given to the lane alignment if a street exists on the opposite side of the arterial street.

### 2.9.2 Street Terminations and Alleys

#### Cul-de-Sac Streets

Cul-de-sac streets in residential subdivisions shall terminate in a circular right-of-way 50’ in radius with an improved traffic turning circle 45’ in radius. The Street Transportation Department may approve an equally convenient configuration where extreme conditions justify.

#### Dead-End Streets

Sites designed with dead-end streets will not be approved except in locations designated by the Street Transportation Department as necessary for future extension in development of adjacent lands. In any

case, a dead-end street serving more than four lots shall provide by easement a temporary turning circle with a 50-foot radius or other acceptable design to accomplish adequate access with an improved surface.

Access roads adjacent to arterial streets will be provided as required by current City standards.

### Alleys

Alley intersections and sharp changes in alignment must be avoided. When intersections or alignment changes are allowed, the inside corners shall be mitered on each side to provide a tangent section between the two sides as shown in **Figure 2.9-1**.

When alleys are provided, they shall be 16' wide where there is single-family residential zoning on both sides; and 20' wide if abutting or in multi-family zoning district or in commercial and industrial zoning districts. Alley intersection and sharp changes in alignment shall be avoided. Dead-end alleys shall be prohibited except when necessary for future extensions. All initial partial alleys shall have a minimum width of 12'. Alleys are to be constructed as follows:

1. Alleys intersecting at right angles shall have a triangle to assist turning vehicles at the inside of the right-angle turn, dimensioned as shown in the table below.

<i>ALLEY #1 (Width)</i>	<i>ALLEY #2 (Width)</i>	<i>ALLEY TRIANGLE</i>
16'	16'	15' x 15'
16'	20'	15' x 15'
20'	16'	15' x 15'
20'	20'	10' x 10'

2. If it is not possible to obtain a triangle, an additional area as shown is required.

<i>ALLEY #1 (Width)</i>	<i>ALLEY #2 (Width)</i>	<i>WIDTH (A)</i>
16'	16'	10'
16'	20'	10'
20'	16'	6'
20'	20'	6'

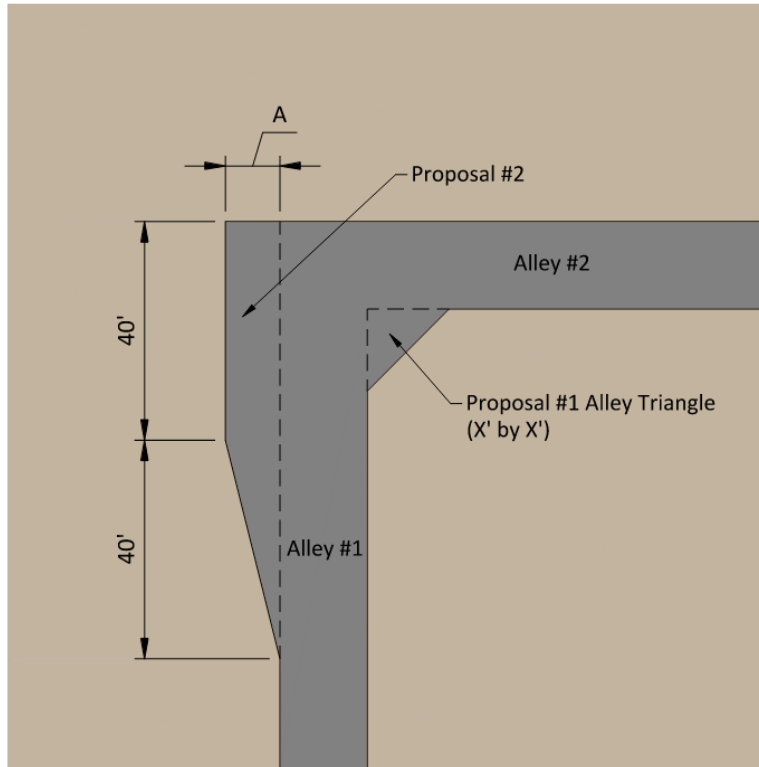

Figure 2.9-1 Alley Triangle

# 3. STREET CONSTRUCTION

## OVERVIEW

This chapter provides information specific to construction of City of Phoenix streets. Topics addressed include pavement design, culverts, stormwater management, and green infrastructure, among others.



## Chapter 3 --- STREET CONSTRUCTION

This chapter provides information specific to the City of Phoenix and provides reference sources for design guidance.

### 3.1 PAVEMENT DESIGN

This section describes references for procedures to be used in the design of the structural section of flexible pavements which are to be constructed in Phoenix's public rights-of-way.

#### 3.1.1 Definitions

- **Structural section:** the combination of an asphalt concrete surface course and a base course of either rock aggregate materials or asphalt concrete.
- **Subgrade:** native soil or fill material over which the structural section is to be placed.
- **Asphalt concrete course:** the total depth of asphalt concrete which may be placed in one or more layers. The upper layer is called asphalt concrete surface course (ACSC) and the lower layer is called asphalt concrete base course (ACBC).
- **Rock aggregate base material:** the total depth of rock aggregate material which may be placed in one or two layers. If one layer is placed, it shall be "Aggregate Base Course" (ABC) in accordance with Table 702 of the MAG Specifications. If two layers are placed, the top 4" must be ABC and the bottom layer may be ABC or "Select material" in accordance with Table 702 of the MAG Specifications. The rock aggregate base material is called the "base course" in this manual.

#### 3.1.2 Geotechnical Investigation Requirements

General procedures for geotechnical investigation are provided in the City of Phoenix Street Transportation Department Design and Construction Management Division, Administrative Procedure (AP) No. 155, Project Development Requirements and Guidelines.

A geotechnical investigation shall be performed for all projects that include roadways; major structures in the right-of-way, such as bridges or box culverts; or underground facility design, including storm drain, water, and sewer. Additional borings shall be taken to clearly define limits of anomalous conditions including, but not limited to, poor soil conditions, hard rock if encountered, etc.

In addition to soil borings, most projects that have significant underground work shall also require seismic refraction surveys to provide understanding of subsurface soil conditions.

City of Phoenix shall review the Consultant's geotechnical report and recommended pavement structural section(s) for the new pavement.

#### 3.1.3 Design Parameters

##### Resilient modulus (MR)

MR can be determined by any of the following methods:

- From relationships proposed by AASHTO,  
 $MR=1000+555 \cdot R\text{-value}$  (for R-value < 20) or

$$MR \text{ (psi)} = 2555 \text{ (CBR)}^{0.64}$$

- B. From back-calculation of surface deflections measured using non-destructive devices such as Dynaflect or Falling Weight Deflectometer (FWD)
- C. From laboratory test on representative sample using AASHTO T274 procedure
- D. From Arizona Department of Transportation (ADOT) procedure using actual and correlated R-values.

The geotechnical engineer utilizes engineering judgment in choosing the most appropriate value of resilient modulus for the design.

### Reliability

Arterials Reliability=95%

Collectors Reliability=90-95%

Local Streets Reliability=80%

### Overall Standard Deviation(s)

Arterials s=0.4

Collectors and local streets s=0.45

### Serviceability

Initial serviceability  $P_o=5.0$

Terminal serviceability  $P_t=2.5$

Change in serviceability index  $PSI=2.5$

### Regional Factor

This factor is used to adjust the Structural Number for climatic and environmental conditions different from those of the AASHTO road test site. The Regional Factor to be used for Phoenix is 1.0.

### Projected Traffic Loading

The Projected Traffic Loading is based on the cumulative expected 18-kip single axle load (ESAL) during the analysis period, which is a minimum of 20 years. The information is typically obtained from project specific traffic studies or geotechnical design reports.

### Design Procedure

Pavement thickness designs shall be determined using the *AASHTO Guide for Design of Pavement Structures 1993 version* (1993 AASHTO Guide) except as modified herein. The minimum thickness of asphalt concrete shall be calculated using the Layered Design Analysis presented in section 3.1.5 of the 1993 AASHTO Guide. The analysis shall be provided as an appendix in the geotechnical report.

### Unsuitable Subgrade Soils

The geotechnical report shall address and provide roadway subgrade mitigation measures for conditions including, but not limited to, the following with concurrence of the City's materials Lab:

- Moderate to high plasticity and/or expansive (swelling) soils per **Table 3.1-1**.
- Non-granular soils with % fines >35% and Plasticity Index >10.
- Collapsible soils.
- Otherwise poor subgrade soils.

Table 3.1-1 Expansion Potential Mitigation

Expansion Potential	Recommended Treatment
< 2 percent	None
2 percent to 5 percent	Stabilize <sup>a</sup> in-place to depth determined by designer, but not less than 8"
> 5 percent	Stabilize <sup>a</sup> in-place to depth determined by designer, but not less 12"

<sup>a</sup>The soil can be stabilized with either lime, cement, or lime/cement combination by specifying the requirements of MAG Section 309 Lime Slurry Stabilization or MAG Section 311 Soil Cement Base Course. For either method, a minimum compressive strength of 160 psi shall be achieved when tested as required by the specification.

The soil should be stabilized with lime in at least two layers following the requirements of MAG Section 311. The bottom layer can be stabilized in place.

### Structural Coefficients

Design structural number (SN) can be converted to thickness of various flexible pavement layers by using structural layer coefficients. In the absence of specific values, the following structural coefficients are recommended (Table 3.1-2):

Table 3.1-2 Structural Coefficients

Material	Structural Coefficient
Asphaltic Concrete	0.39
Aggregate Base	0.12
Select Material	0.11
Cement Treated Base	0.27
Bituminous Treated Base	0.31

### Minimum Pavement Thickness

For the City’s streets, the following are provided as the minimum allowable thicknesses for asphaltic concrete and base materials or full-depth sections on prepared subgrade (Table 3.1-3). Minimum pavement thickness only applies after a 20-year pavement design is conducted and the resulting design pavement thickness is less than the required minimum values in Table 3.1-3. If the resulting pavement design is thicker than the minimum, then the design thickness applies.

Table 3.1-3 Minimum Pavement Thickness

Street Type	Option 1		Option 2
	AC	ABC	Full-Depth AC on Prepared Subgrade
All Arterial Classifications	6"	8"	9"
All Collector Classifications <sup>1</sup>	5"	8"	8"
Local and Cul-de Sacs <sup>2</sup>	3"	6"	5"

1. Also applies to local commercial/industrial streets
2. Also applies to paved alleys

### Asphaltic Concrete Mixes

The following mixes and oil contents are general guides for arterial/high traffic volume streets and local streets/low volume streets.

**Arterial/Collector Streets/High Traffic Volume:**

A-1 1/2" Base Course only, Asphalt Binder Content: 4.3 +/- 0.4%

C- 3/4" Base and Surface Course, Asphalt Binder Content: 5.0 +/- 0.4%

D- 1/2" Surface Course only, Asphalt Binder Content: 5.1 +/- 0.4%

D-1/2" or Polymer modified Asphalt Concrete Surface course only, Binder: 8.0 +/- 0.4%

**Local Streets/Low Traffic Volume:**

C- 3/4" Base and Surface Course, Asphalt Binder Content: 5.5 +/- 0.4%

D- 1/2" Surface Course only, Asphalt Binder Content: 5.6 +/- 0.4%

D-1/2" or Polymer modified Asphalt Rubber Concrete Surface Course only, Binder 8.5 +/- 0.4%

The current list of approved mixes can be found at the following link:

<https://www.phoenix.gov/streetssite/Pages/COP-MaterialsLab.aspx>

The City of Phoenix Materials Lab can review other asphalt mixes for use on a project-by-project basis.

**Substitution of Asphalt Concrete for Aggregate Base Material**

If the total structural section depth determined is undesirable, a deeper asphalt concrete section can be used in lieu of some or all the aggregate base material at a rate of 1" of asphalt concrete for 3" of aggregate base material.

**Recycled Asphalt Concrete and Asphalt Millings (RAP)**

If these materials meet the MAG specifications for aggregate base course, then these materials shall be allowed in sub-base and as backfill. However, RAP can be used in the pavement structure on a case-by-case basis only with the approval of the Engineer and the City's Materials Lab and appropriate client Department.

**3.2 CULVERTS**

Storm drain design will be consistent with the most recent version of City of Phoenix Storm Water Policies and Standards.

**3.2.1 Poured-in-Place Reinforced Concrete Arches Bridges in Subdivisions**

City of Phoenix receives occasional requests to install poured-in-place reinforced concrete arch bridges, tunnels, and culverts. It is the policy of City of Phoenix that, if installed, they will be maintained by the developer, homeowners' association, or neighborhood. A maintenance agreement between the City of Phoenix and the developer, homeowners' association, or neighborhood is required, as part of the platting and development approval process, for installation of poured-in-place reinforced concrete arch system.

Poured-in-place reinforced concrete-arch bridges, tunnels, and culverts shall be designed with pedestrian facilities (sidewalk) and access ramps both upstream and downstream.

**3.2.2 Culverts Under Half-Streets**

A culvert provided in conjunction with half-street construction (**Figure 3.2-1**) must extend beyond the edge of the traveled way a minimum of 10' into the area where the other half of the street shall be constructed in the future. The 10' distance is measured perpendicular to the street alignment. The



culvert capacity, flow line slope, and alignment must be based upon the ultimate design requirements for the culvert if it were to be built under the full cross-section where it could be considerably longer.

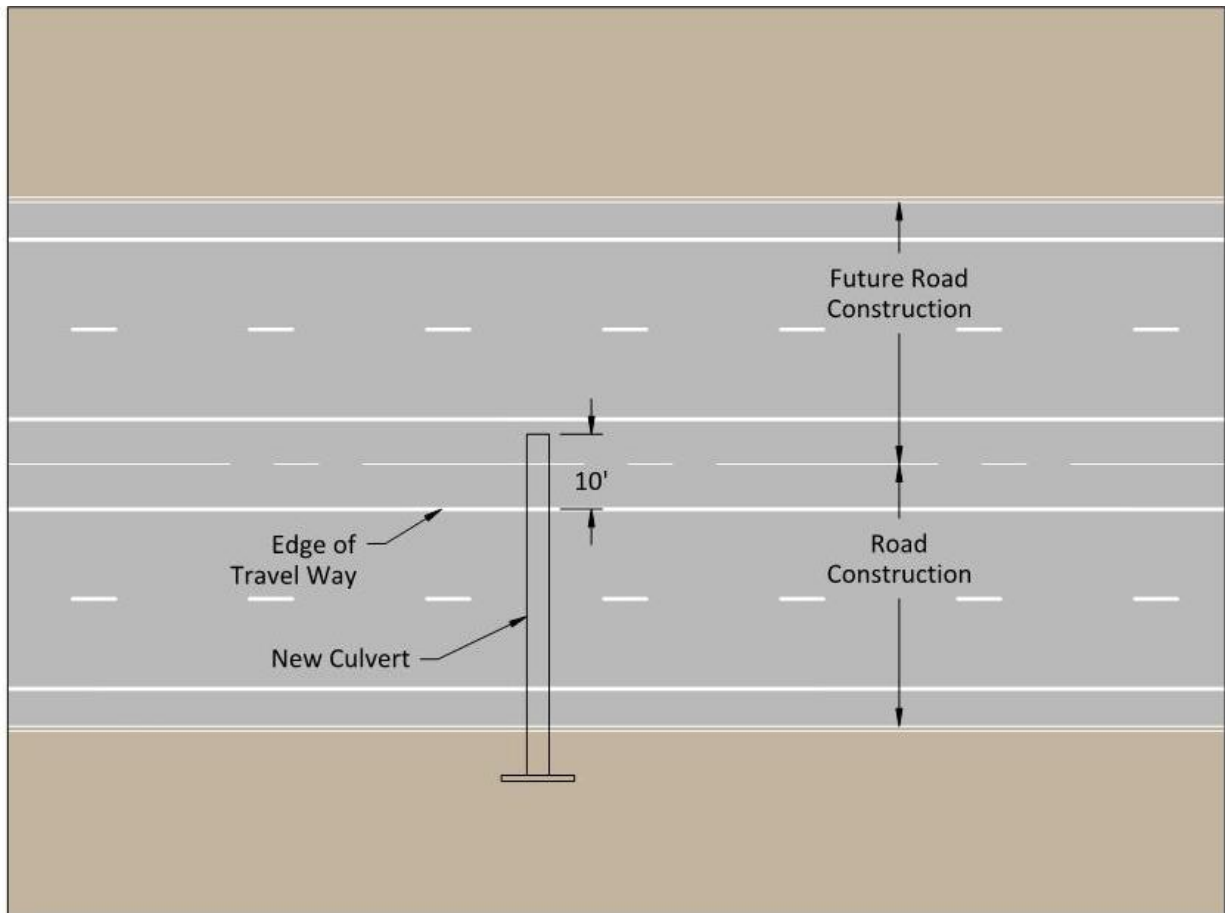

Figure 3.2-1 Culvert Under Half-Street

### 3.3 BRIDGES AND MAJOR STRUCTURAL PLANS

#### 3.3.1 Bridges

ADOT Standard Specifications and Details serves as primary design reference for major structures, such as bridges, culverts, or special vaults. The Consultant shall provide any necessary special provisions or details.

City of Phoenix requires Load and Resistance Factor Design (LRFD) method. The Consultant shall verify the required method with the City of Phoenix Project Manager at the time of project scoping.

The Consultant shall refer to City of Phoenix Storm Water Policies and Standards Manual (<http://phoenix.gov/STREETS/index.html>) for other bridge design criteria.

The City of Phoenix Administrative Procedure (AP) No. 155, Project Development Requirements and Guidelines provides information on the sheet sequence for bridge and other major structural plans and references for bridge design guidelines. If a bridge structure exceeds 20' in length, there is a need to request a bridge number from ADOT.

### Bridge Roadbed Width

The clear width of all bridges, including grade separation structures, shall equal the full width of the physical improvements of the approaching roadway, consisting of sidewalk, street, median, and curb and gutter.

### Approach Guardrail

If a vehicular railing or safety-shaped barrier is provided, which is within 10' of a traveled way with or without a sidewalk, approach guardrails should be installed on all approach ends in accordance with AASHTO guidelines.

Several types of approach railings are available, including Metal Beam Guardrail, Bridge Approach Guardrail (Types I and II), and Safety-Shape Barriers. The type of approach railing selected should match the rail to be used on the bridge. When long runs of guardrail (such as embankment guardrail) precede the bridge, the guardrail should connect to the bridge railing and thus serve the approach railing function.

### Cross Slope

The crown is normally centered on the bridge except for one-way bridges, where a straight-cross slope in one direction shall be used. The cross slope shall be the same as for the approach pavement.

### Median

On multi-lane divided highways, a bridge median that is 26' wide or less shall be decked. The decking of all medians greater than 6' wide should be grated to allow natural light into the structure. Exceptions must be submitted to the Street Transportation Department for approval.

### Railings

The railings to be used are the ADOT standard design railings.

## 3.3.2 Structural Clearances

### Horizontal Clearance

All roadways shall comply with its approved street cross sections which all include a curb, gutter, and sidewalk. For curbed sections, the MUTCD, in chapter 2 and chapter 4, indicate that the distance for objects behind a curbed section shall be a minimum of 2' from the face of the curb. Designers should increase that distance when practicable.

If a standard street cross section cannot be constructed for a segment of roadway, then a clear zone shall be provided along that segment. The term "clear zone" is used to designate the unobstructed, relatively flat area provided beyond the edge of the traveled way for the recovery of errant vehicles. The clear zone includes any shoulders or auxiliary lanes. Horizontal clearances must follow AASHTO roadside design guidelines and ADOT standards. Horizontal clear zone requirements are presented in **Figure 3.3-1** and **Table 3.3-1**. If the clear zone requirements cannot be met at a segment of roadway, a guardrail section shall be used along that segment. Guardrail design shall be consistent with ADOT standards.

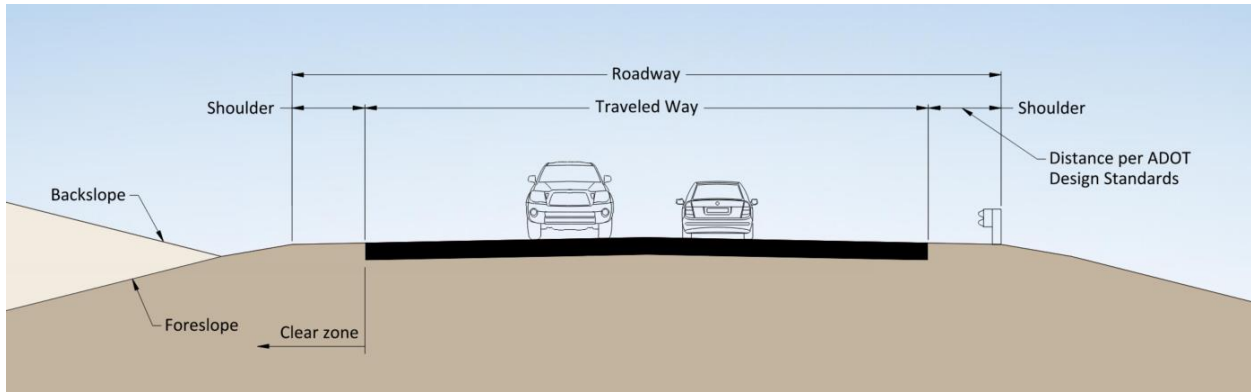

Figure 3.3-1 Horizontal Clearance Requirements

Table 3.3-1 Preferred Clear Zone Distances

	Fore slopes		Backslopes		
	6:1 or flatter	Steeper than 6:1, up to and including 4:1	Steeper than 4:1	4:1 or flatter, up to 6:1	6:1 or flatter
40 mph or less	16	18	16	16	16
45 – 50 mph	22	28	16	20	22
55 mph	24	32	18	22	24
60 mph	32	44	22	26	28

### Vertical Clearance

The minimum vertical clearance shall be 16.5' over the entire width of the traveled way of an arterial street or major collector street. On other streets, the minimum shall be 14.5'. Exceptions must be submitted to, and approved by, the Street Transportation Department. Vertical clearance requirements are shown in **Figure 3.3-2**.

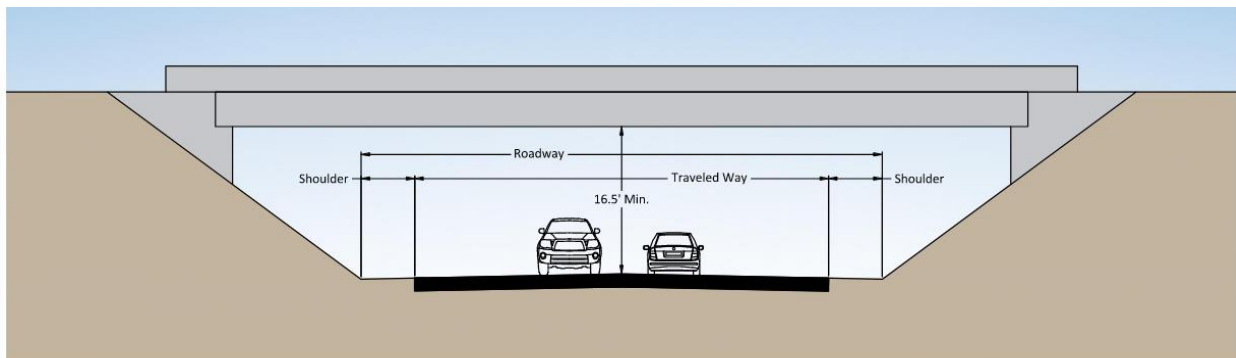

Figure 3.3-2 Vertical Clearance Requirements

### 3.4 CUT OR FILL SLOPES

Side slopes shall be designed for functional effectiveness, ease of maintenance, and pleasing appearance. Cut or fill lines shall be shown on the plans and roadway typical sections where significant cuts or fills shall be required to match proposed work to existing adjacent property.

The maximum slope of the cut or fill slope behind a sidewalk or shoulder area is 4:1. Cut slopes steeper than 4:1 may need to be set further back from the roadway or sidewalk. Retaining walls may be necessary. Fill slopes steeper than 4:1 may require vehicular protection, such as guard rail or barrier wall.

The top of all cut slopes shall be rounded where the material is other than solid rock. A layer of earth overlaying a rock cut also shall be rounded. The top and bottoms of all fill slopes for, or adjacent to a traveled way, sidewalk, or bicycle path shall also be rounded. Cut or fill slope requirements are presented in **Figure 3.4-1**.

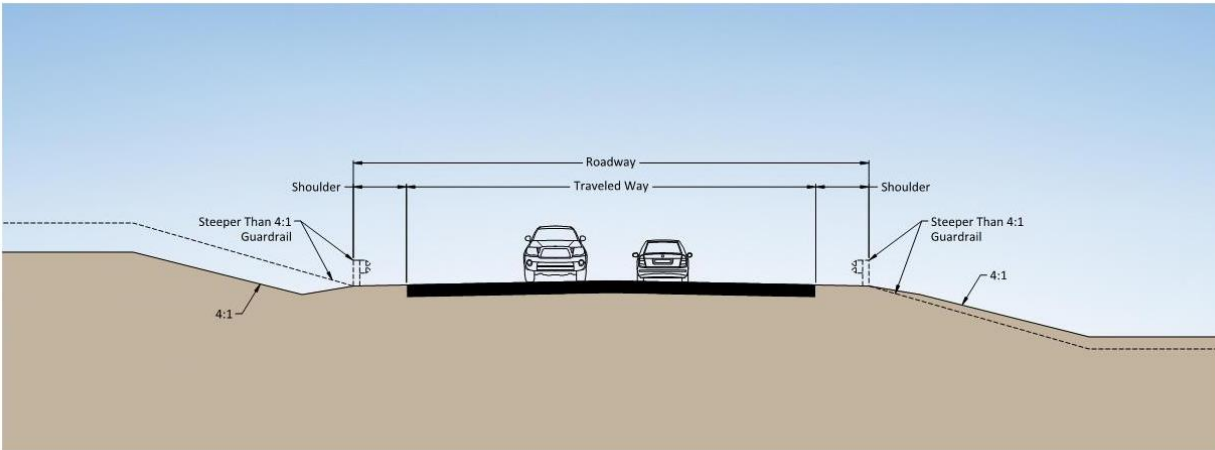

Figure 3.4-1 Cut or Fill Slopes

### 3.5 PAVEMENT TRANSITIONS

When development causes the widening of a portion of the pavement of an existing road, transitions between pavements of different widths should be consistent with the design standards of the superior facility. Taper treatments for lane transitions are discussed in Chapter 2, Section 2.3.5, Lane Transition Tapers.

### 3.6 STORMWATER MANAGEMENT

Design and construction guidance is provided in the most current version of the *City of Phoenix Storm Water Policies and Standards*.<sup>4</sup>

The City of Phoenix also uses storm water design software – Drainage Design Management System for Windows (Phoenix – DDMSW).

### 3.7 GREEN INFRASTRUCTURE

Green infrastructure (**Figure 3.7-1**) are techniques designed to help mitigate flooding, reduce runoff and stormwater, reduce heat-island effect, preserve natural wildlife. Common examples of green infrastructure are vegetated bioswales or stormwater harvesting basins, permeable pavement/pavers, and curb openings, sediment traps, and dome overflow structures.

<sup>4</sup> <https://www.phoenix.gov/streets/reference-material/sw-manual>.

The information in this section is based on the *Greater Phoenix Metro Green Infrastructure and Low Impact Development (LID) Handbook* (2019). Current City adopted LID details are available in the City of Phoenix Supplement to the MAG Uniform Standard Specifications and Details.

### 3.7.1 Permeable Pavement

Permeable pavements can effectively reduce pollutants and elements can include pervious concrete, pervious concrete pavers, and permeable pavement with underground reservoir and underdrain.

Permeable pavement is not appropriate for use on areas exposed to vehicular traffic within the right-of-way. However, permeable pavement and pavers could potentially be used for private development on-site uses and privately maintained parking areas.

Refer to MAG Uniform Standard Specifications for Public Works Construction, Section 323, Placement of Pervious Concrete and Section 723, Pervious Concrete.



**Green Infrastructure**

*Figure 3.7-1 Green Infrastructure*

### 3.7.2 Low Impact Development Curb Openings

Curb openings (LID-02 and LID-03) convey runoff into and out of features, such as swales or bioretention areas. This treatment can be retrofitted into an existing roadway or can be built as part of new construction. Considerations for use of these curb openings are:

- Acceptable for use with detached sidewalks. Curb openings are not recommended for use with attached sidewalks.
- Minimum 24" curb opening required to prevent clogging.
- A private maintenance agreement issued by the street transportation department is required in coordination with use of bioswales or bioretention areas within the right of way.
- Use in combination with MAG Detail 206, Concrete Scupper. The metal plate on top of the curb opening, as shown in the details, is not required.

### 3.7.3 Sediment Traps

Sediment traps should be installed at curb openings and/or inlets that receive concentrated stormwater flows. A sediment trap provides a collection point for sediment and other debris before runoff enters a stormwater capture or LID facility. They are typically used in conjunction with curb openings and vegetated/rock bioswales.

### 3.7.4 Stormwater Harvesting Basins

Stormwater harvesting basins (**Figure 3.7-2**) are shallow vegetated earthen depressions that collect stormwater and cleanse it prior to the water percolating into the subsurface. These differ from typical retention basins in that they provide subsurface storage within the constructed facility. Harvesting basins require a larger area to implement. Implementation considerations are:

- This feature is appropriate for use in subdivisions.
- Because of space requirements, it is typically not suitable for use on public road projects, however there may be occasions when appropriate right-of-way space is available to accommodate this feature. Stormwater harvesting basins are not permitted along arterials.
- Basins are not permitted along arterial classified streets.

### 3.7.5 Vegetated or Rock Bioswales and Bioretention Systems

#### Vegetated or Rock Bioswales

Vegetated/rock swales are open, shallow channels that may have trees, grasses, and other low-lying vegetation covering the swale bottom and side slopes, with pervious surface materials, such as decomposed granite, larger rocks, and/or mulch. Vegetated or rock bioswales are designed to slow the flow of runoff to downstream discharge points. When landscaped, vegetated swales may provide additional pollutant removal. Bioswales can provide water harvesting opportunities, depending on the

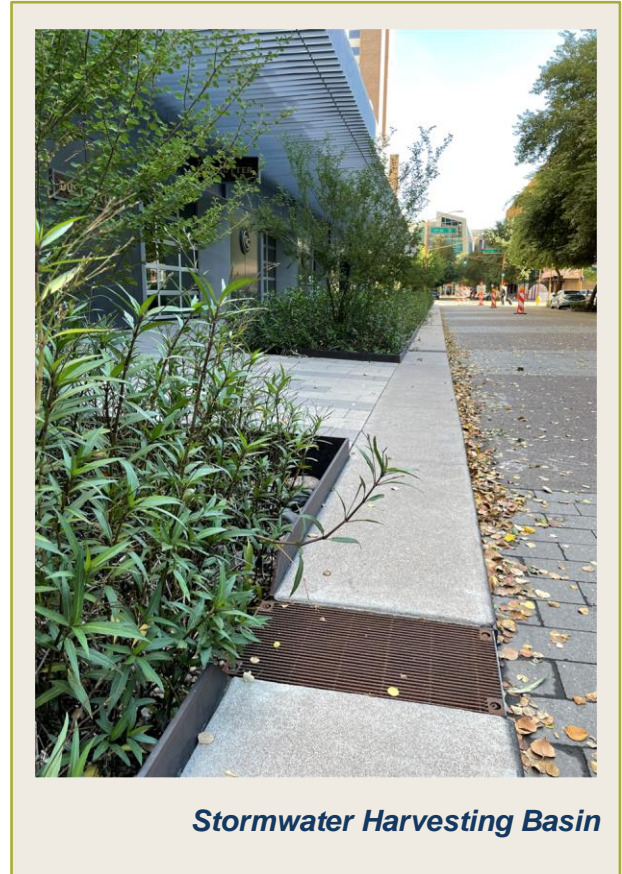

**Stormwater Harvesting Basin**

*Figure 3.7-2 Stormwater Harvesting Basin*

site conditions and their hydraulic requirements. Similar to stormwater harvesting basins, a larger area is required to construct this feature. Implementation considerations are:

- Bioswales are more suitable for use in subdivisions.
- Can be used on public road projects if sufficient right-of-way is available.
- Bioswales are not permitted along arterial classified streets.

### Bioretention Systems

Bioretention systems (LID-07) may either allow percolation into the subsoil or may have an underdrain that directs infiltrated stormwater to a downstream drainage system. These differ from stormwater harvesting basins and rain gardens because they are generally deeper, and their main purpose is to capture pollutants and to provide a medium to infiltrate stormwater. Implementation considerations are:

- Bioretention systems require space and are more suitable for use in subdivisions.
- Can be used on public road projects if sufficient right-of-way is available.
- Bioretention systems are not permitted along arterial classified streets.

### 3.7.6 Domed Overflow Structures

Domed overflow structures (LID-10) allow for ponding within multiple stormwater capture facilities and provide an outlet for larger storm events that exceed the capacity of each facility. Overflow structures drain into a downstream collection system, such as a storm drain, basin, channel, or natural wash.

Implementation considerations are:

- Suitable for public and private road projects within the right-of-way.
- A maintenance agreement is required for use in subdivisions or private development projects.

## 3.8 RIGHT-OF-WAY MANAGEMENT PROCEDURES

The City has procedures in place to assure that construction, maintenance, and events within street right-of-way are planned to minimize the disruption of traffic and maximize access to adjacent land use. These procedures are contained in the City of Phoenix Traffic Barricade Manual, 9<sup>th</sup> Edition and more information on certifications, Temporary Restrictions and Closures (TRACS) permits, regulations for traffic restrictions, and special requirements for the Phoenix downtown area are available through the Right-of-Way Management Program Office.

For private development projects within the downtown area (**Figure 3.8-1**), developers shall submit a Construction Logistics Plan to the Planning and Development Department for approval prior to building permit issuance.

Construction scheduling is provided on the City Manager's Construction Project Map.

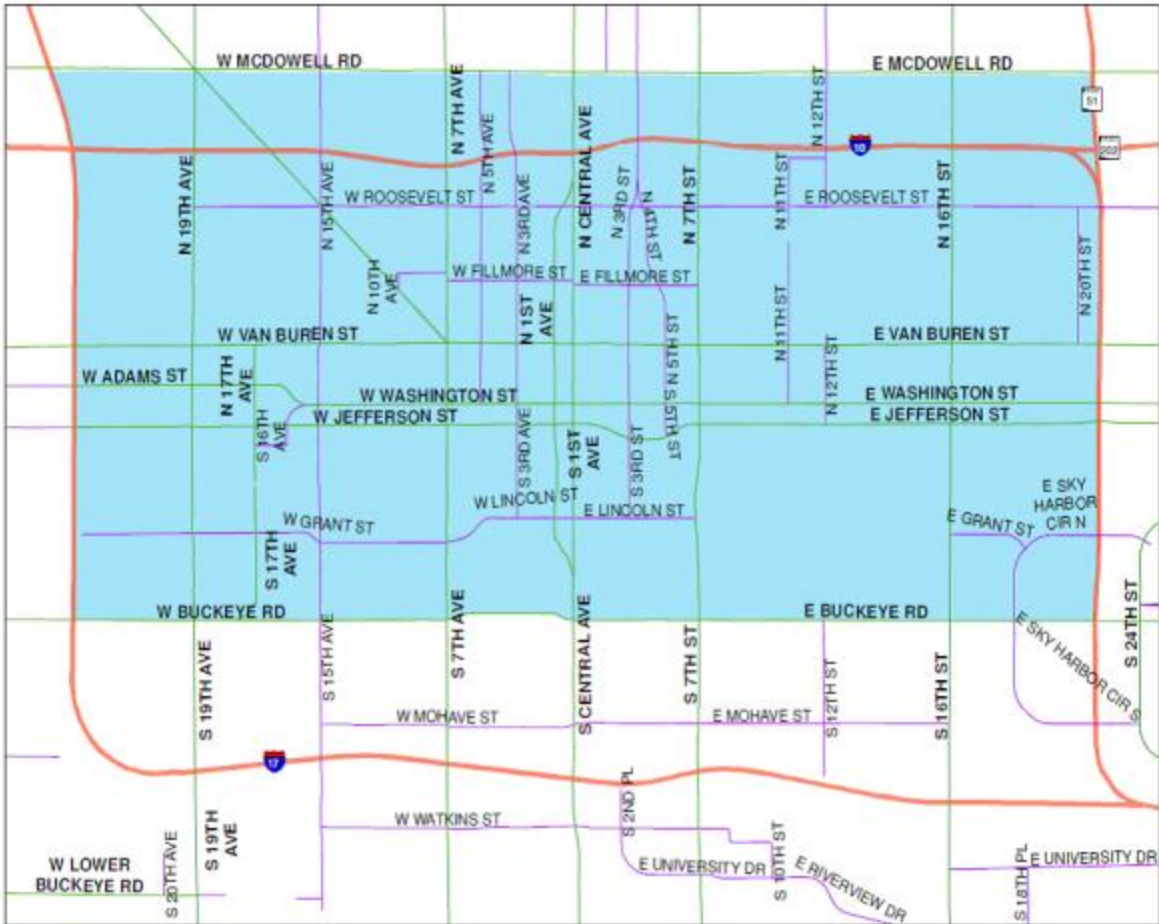

Figure 3.8-1. Downtown Right-of-Way Management Area Map



# 4. TRAFFIC SIGNALS, SIGNING + STRIPING



## OVERVIEW

Chapter 4 provides an overview of City of Phoenix traffic design practices to assist consultants and others who are preparing traffic signal, signing, and striping plans for the City of Phoenix.



# Chapter 4 --- TRAFFIC SIGNAL, SIGNING, AND STRIPING

## 4.1 INTRODUCTION

This chapter provides an overview of City of Phoenix traffic design practices to assist consultants and others who are preparing traffic signal, signing, and striping plans for the City of Phoenix.

### 4.1.1 Traffic Design References

All traffic signal, pavement markings, and sign plans must satisfy the current edition of the following guidelines and references:

- *City of Phoenix Standard Traffic Signal Details* [<https://www.phoenix.gov/streets/reference-material>]
- *City of Phoenix Standard Pavement markings and Sign Details* [<https://www.phoenix.gov/streets/reference-material>]
- *City of Phoenix Street Transportation Department, Administrative Procedure (AP) No. 155, Project Development Requirements and Guidelines, 2012*
- *U.S. Department of Transportation Federal Highway Administration, MUTCD, 2009*
- *Arizona Supplement to the MUTCD, 2009*

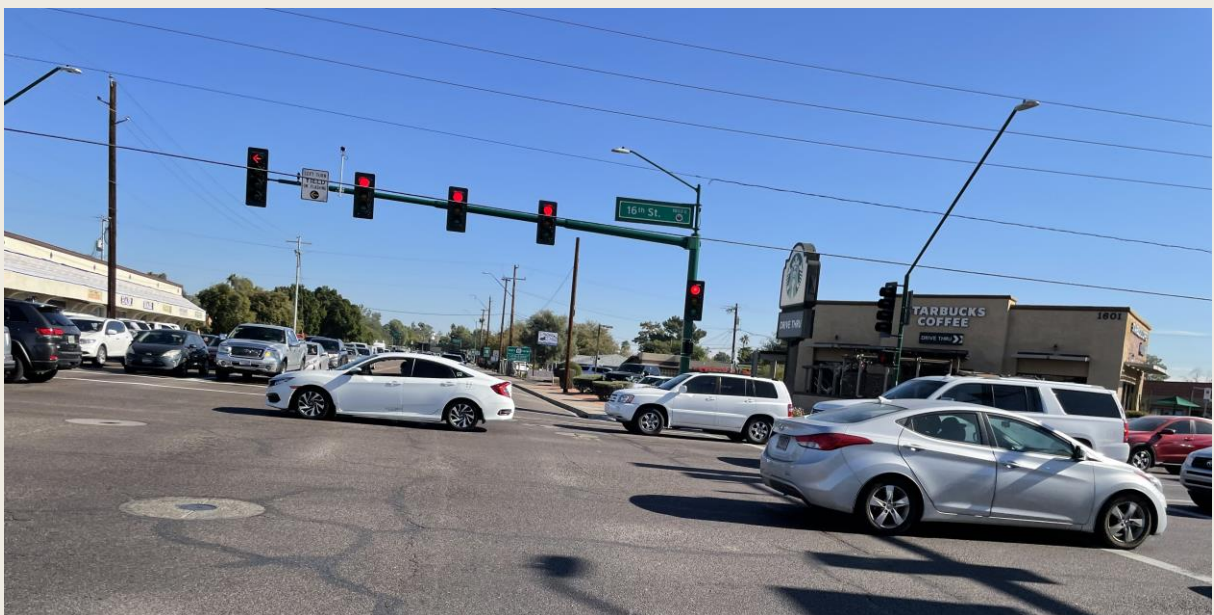

*Traffic Signal at 16<sup>th</sup> Street and Bethany Home Road*

## 4.2 TRAFFIC SIGNAL DESIGN

The City maintains standard detail sheets and specifications for traffic signal installation at: <https://www.phoenix.gov/streets/reference-material>.

### 4.2.1 Developer Traffic Signal Work Overview

Improvements within the right-of-way may require relocation of existing traffic signal equipment, installation of new traffic signals, or installation of conduit/junction boxes for a future signal. These are typically triggered under the following scenarios.

- 1) Physical change to an intersection:
  - a. Adding roadway curb returns
  - b. Adding or upgrading ramps, or other improvements to comply with ADA requirements and City of Phoenix traffic signals standards
    - i. Ramps should be upgraded if the facility only has a single ramp (diagonal or apex ramp).
    - ii. Dual ramps should be installed at all signalized intersections unless the designer (developer/staff/etc.) has completed a technical feasibility to determine the design has provided the Maximum Extent Feasible (MEF) threshold for design improvements.
  - c. Expansion of existing roadway, such as lanes of traffic and turn lanes.
- 2) Operational change based upon development scope:
  - a. Traffic Impact Analysis requirement - Signal modification to mitigate increased capacity, such as adding vehicle movement to and within an intersection
  - b. One or more traffic signal warrants are met
  - c. Master Street Plan Document calls for new signal



**Curb Ramp Under Construction**

- 3) Future Signalized Intersection
  - a. Conduit and junction boxes are required to be installed to facilitate future signalization

For projects not initiated by the City, the developer shall bear the full responsibility and cost for all associated signal work.

### 4.2.2 Development Review Process

Traffic impact, street improvements, and traffic signal installation or

modification requirements are determined during the site plan review process. Street Transportation. Development Coordination Division's Traffic Engineer coordinates with the Planning and Development Department to review site development applications and provides comments to developers regarding

their street and traffic improvement or mitigation requirements. Street Transportation staff provide initial comments with the Preapplication Site Plan review.

Traffic Impact Studies are required to be approved prior to submission of Preliminary Site Plans so that all off-site traffic and roadway improvements are clearly indicated with Preliminary Site Plan approval.

Traffic signal and roadway improvements may be required beyond those identified in the initial review of the preliminary site plan and/or associated Traffic Impact Study, due to prior-approved planning documents, such as a Master Street Plan, paving plans for an adjacent development.

### **4.2.3 Traffic Signal Plans**

The developer is responsible for providing or paying for traffic signal plans for all signal work that will be a part of their project. This requirement is for traffic-signal modification of existing signals, constructing new traffic signals, and conduit-only plans. Signal plans require the full extent of the intersection with new work clearly identified, and unmodified equipment to be shown as existing. Signal plan notes will indicate the division of labor.

Final approved developer signal plans shall be signed by Deputy Director of Traffic Services Division. An approved set of plan documents shall be present on the job site during construction.

### **Developer Costs and Escrow Account**

All work and costs incurred related to the construction, modification, or reconstruction of the intersection traffic signal is the responsibility of the developer. Traffic Services will provide a detailed cost estimate of the traffic signal work that includes a lump sum cost for signing and markings. The City of Phoenix policy requires that the developer provide a check in the amount of the estimate to create an escrow account to cover the amount of the estimated work.

Escrow accounts are set up and funded prior to any traffic signal final design and construction. The Traffic Signal Engineer and the Development Coordination Traffic Engineer will establish the appropriate cost share percentage for the project. When the development creates a need for a new traffic signal, the developer shall cause the installation of the signal at their full expense.

Traffic Services completes and submits a Capital Improvement Project (C.I.P.) request project form accompanied by a copy of the developer's check.

The Street Transportation Department establishes a project number to bill against. At the end of the project, the City prepares a final bill and either bills for any overage or refunds the remaining amount in escrow to the payee.

### **Maintenance of Traffic**

As part of any site plan improvement that encroaches into the public right-of-way, a Temporary Restriction and Closure System (TRACS) permit will be required. The City of Phoenix Barricade Manual ([https://www.phoenix.gov/streetsite/Documents/d\\_039129.pdf](https://www.phoenix.gov/streetsite/Documents/d_039129.pdf)) includes the requirements and procedures to obtain this permit. The TRACS process is the City's mechanism to ensure safe operation and minimal disruption to the travelling public during construction activity on Phoenix streets. The required plans vary with the complexity of work and traffic design should generally consider constructability to assist in efficient installation.

## 4.3 PAVEMENT MARKINGS AND SIGN PLANS

The City of Phoenix relies on a streamlined approach to the design and installation of pavement markings and signs. The City of Phoenix fabricates and manages installation of all signs on public streets. The City of Phoenix installs all pavement markings on public streets.

The signing of streets and public rights-of-way is a critical design element. Sign choices, locations, and installation types can significantly impact their effectiveness for the intended use. All sign installations shall include a review of existing sign locations and types and a field review of existing conditions and visual sight lines to meet the intended use.

Final approved developer Pavement Marking and Signing plans shall be signed by Deputy Director of Traffic Services and Traffic Engineering Supervisor. An approved set of plan documents shall be present on the job site during construction.

### 4.3.1 Design – Signs and Pavement Markings

The City maintains standard detail sheet and a template CAD file that includes City of Phoenix standard blocks, line types, and title blocks. This template will be used to expedite the drafting and approval process. These standards and templates can be found at: <https://www.phoenix.gov/streets/reference-material/dcm-autocad-standards>. Signing and striping plans shall conform to the design information from the other applicable chapters of this manual.

### 4.3.2 Developer Requirements

Sign and pavement marking plans are required for any development project that impacts an existing City sign or will require the installation of any new sign or pavement marking. This requirement may be established as early as Preapplication Site Review, or as required as part of off-site paving plans submitted into the City. The developer is responsible for the cost of providing engineered drawings of signing and striping required as part of the development. The City performs the installation of any signing and pavement markings, or as required through permit procedures of the Planning and Development Department.

Traffic Services will review all Pavement Marking and Sign Plans and provide comments and feedback prior to approval of plans. **Paving plans will not be approved until the Pavement Markings and Sign plan has been approved.** Developers are encouraged to engage with Traffic Services early in the process for design assistance and informal feedback prior to filing of permits. Traffic Services holds weekly plan reviews. Developers may attend these meetings to receive input from Traffic Services engineers. Traffic Services may be contacted at 602-262-4659.

### 4.3.3 Signing

To eliminate unnecessary signposts, every effort should be made to use existing streetlights where applicable. Some types of signs, such as STOP signs, are in critical locations and cannot be moved to the nearest street light pole but many others, such as parking and speed limit signs, may be universally mounted on the nearest light pole.

Traffic signal poles are normally not to be used for sign placement. However, some signs, such as turn restrictions, large street-name signs (G-4), ONE WAY, KEEP RIGHT, and lane-control signs are intersection-related and are suited to signal pole mounting. Care must be taken to ensure that installing these signs on signal poles would not interfere with the pedestrian push-button signs.

#### **4.3.4 Pavement Markings**

The developer/contractor will be responsible for the removal of existing pavement markings as shown on the approved plans, or as directed by the inspector. The removal of pavement markings is preferred by a pavement treatment as defined in the City of Phoenix pavement cut ordinance.

An edge lane shall be installed on all arterials streets that do not have adjacent curb or gutter. When a bike lane is present the edge stripe is omitted.

Crosswalk striping shall be provided at all signalized intersections and all existing striped crosswalks. Or as determined by the Street Transportation Department.

#### **4.3.5 Citizen Initiated Requests**

Citizen requests for traffic signals are made to the Arterial Systems Management Section of the Street Transportation Department. Requestors can contact 602-262-6021 for further information or to report traffic signal problems 24 hours/7 days a week.

Citizen requests for signing and/or striping modifications are made to the Traffic Operations Section of the Street Transportation Department. Requestors can contact 602-262-6549 for further information.

# 5. NEIGHBORHOOD TRAFFIC MANAGEMENT

## OVERVIEW

Chapter 5 provides an overview of allowable traffic calming elements and approaches within City of Phoenix right-of-way, to improve the safety and livability of neighborhoods by reducing vehicular speeds.



# Chapter 5 --- NEIGHBORHOOD TRAFFIC CALMING

## 5.1 INTRODUCTION

Neighborhood traffic calming consists of design elements to improve the safety and livability of neighborhoods by reducing vehicular speeds. This chapter provides an overview of allowable traffic calming elements and approaches within City of Phoenix right-of-way.

## 5.2 RESIDENT REQUESTED TRAFFIC CALMING

The Street Transportation Department offers a program for neighborhoods to request speed humps and speed cushions along local and collector streets.<sup>5</sup> The City of Phoenix offers the traffic calming programs as explained in this chapter.

### 5.2.1 Speed Hump Program

The City of Phoenix has a program for installing speed humps in existing local streets in neighborhood areas where the speed limit is 25 mph. Speed humps, illustrated in **Figure 5.2-1**, are only installed after completion of an approval process, which includes submission of a neighborhood petition.



*Speed Hump*

*Figure 5.2-1 Speed Hump in City of Phoenix*

<sup>5</sup> <https://www.phoenix.gov/streets/neighborhood-traffic-programs-services/speed-hump-program>, and <https://www.phoenix.gov/streets/neighborhood-traffic-programs-services/speedcushions>.



### 5.2.2 Speed Cushion Program

Speed cushions as illustrated in **Figure 5.2-2** are speed humps that include wheel cutouts to allow emergency vehicles (fire trucks) to pass unaffected, while reducing passenger car speeds. They can be offset to allow unimpeded passage by emergency vehicles and are typically used on key emergency response routes. Speed cushions extend across one direction of travel from the centerline, with longitudinal gap provided to allow wide wheelbase vehicles to avoid going over the hump.

*The City of Phoenix only allows speed cushions on public streets classified as minor collector streets in residential areas, with speeds of 30 mph or less. An information packet describing this approval process is available on the program website. Speed cushions should be located periodically along the corridor (every 500') to accomplish speed control.*



Figure 5.2-2 Speed Cushion

## 5.3 TRAFFIC CALMING GUIDELINES

Traffic calming is most effective when it is self-enforcing by providing physical and visual cues in, and adjacent to, the roadway to encourage drivers to travel at slower speeds. The design of the roadway results in the desired effect, without relying on compliance with traffic control devices, such as signals,

signs, and enforcement. Street landscape may complement traffic calming strategies to provide visual cues that encourage people to drive more slowly.

Traffic calming devices should be aligned with open space and pedestrian pathways as much as possible, and consistent with City policies.

### 5.3.1 City of Phoenix Policies

The Phoenix General Plan, Plan Phoenix includes the following goal: *The community should be protected from the negative effects of the volume, speed, and cut-through traffic in neighborhoods (Part III, Core Values, Safe Neighborhoods-Traffic).*

The City of Phoenix Zoning Ordinance, Chapter 5, Section 507 TAB A, Guidelines for Design Review Part II. C. Subdivision Design/Development, states that “Local streets exceeding 600’ in length should incorporate traffic calming measures.”

Any traffic calming that is installed on an existing street will need to complete the Street Transportation Department petitioning process. Traffic calming that is installed on streets before being opened to the public does not require the public petition process.

### 5.3.2 Traffic Calming and Functional Classification

The purpose of traffic calming is to help traffic align with the posted speed limit of the street functional class and nature of adjacent land use. City of Phoenix local streets and collector streets, as defined on the *City of Phoenix Street Classification Map*, are eligible for traffic calming measures.

**Arterials** are major streets, which are typically the major north/south and east/west transportation corridors spaced at each mile. Traffic calming is not constructed on arterial streets as the primary function of arterials is to serve regional traffic. Arterials often connect to freeways, are several miles long, and have higher speeds and higher traffic volumes.

**Collectors** are important transportation corridors generally running on the ½-mile north/south and east/west streets between the arterial streets. Collector streets with multiple lanes in one direction are not eligible for traffic calming. Collector streets with a speed limit of 30 mph or less are eligible for traffic calming.

**Local streets** are typically in residential areas and provide connectivity between collectors and arterials for local traffic. Local streets are eligible for traffic calming.

## 5.4 TRAFFIC CALMING STRATEGIES

### 5.4.1 Speed Humps/Cushions

Speed humps/cushions are only allowed through the city sponsored speed hump program and are not allowed for development use to meet City of Phoenix Zoning Ordinance, Chapter 5, Section 507 TAB A Guidelines for Design Review Part II. C. Subdivision Design/Development for block length mitigation.

### 5.4.2 Speed Tables (Raised Crosswalks)

Speed tables (**Figure 5.4-1 Speed Table**) are longer than speed humps and flat on top rather than the rounded speed hump design. They allow for slightly higher operating speeds and can support transit and emergency vehicle access. They shall be incorporated into mid-block crossings and curb extensions to

increase the safety of such crossings and provide a level surface for pedestrians. Speed tables are not appropriate at intersections.

### Design Considerations

- Permissible on streets with posted speed of 30 mph or less.
- Drainage must be accommodated within the device.
- Clear markings and signage are necessary to alert street users of presence.
- Device works well with curb extensions.
- The flat top shall be a minimum of 10' in width.
- The raised crosswalk location shall be installed in coordination with the City Street Light Policy.



*Figure 5.4-1 Speed Table*

### 5.4.3 Chicanes

Chicanes (**Figure 5.4-2**) are a series of curb extensions, pinch-points, parking bays, or landscaping features which alternate from one side of the road to the other, to establish a serpentine path of travel for motorists along a street. Chicanes reduce vehicle speeds by requiring motorists to shift laterally, by a distance of one half, to one full lane width. Chicanes may provide the opportunity to add street trees; mature tree canopy can have a traffic calming effect along a neighborhood street.

#### Design Considerations

- Device is permissible on streets with posted speed of 30 mph or less.
- Device requires curb and gutter and must accommodate drainage.
- The Chicane location shall be installed in coordination with the City Street Light Policy.
- No driveways or community mailboxes within or near the chicane.
- Device must be at least 500' from nearest traffic calming device.
- Device must be placed at least 200' from a traffic control device.
- Device may require the removal of on-street parking.
- Bike lanes shall be accommodated in the design if on a collector street.

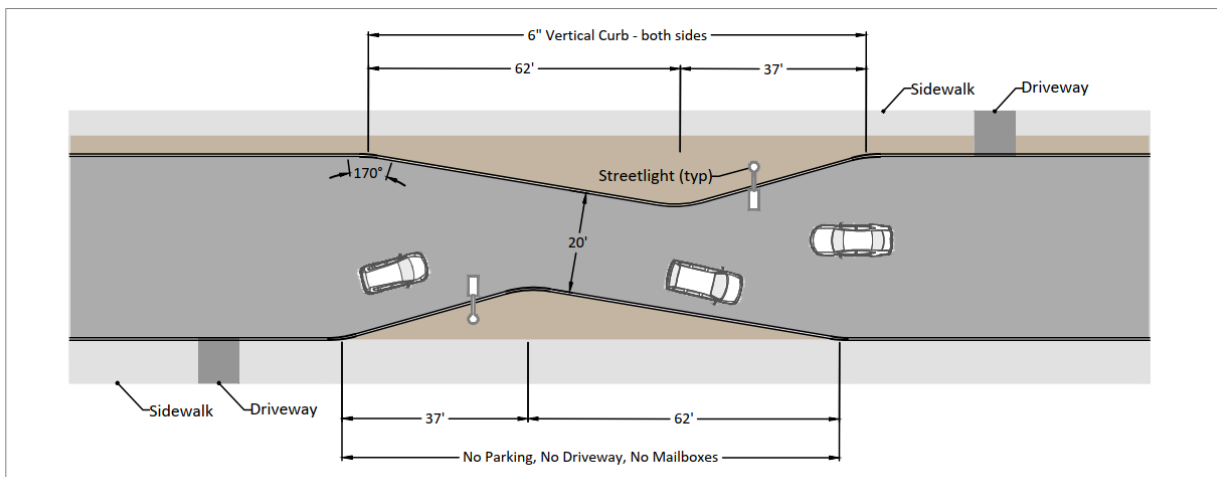

Figure 5.4-2 Chicane

### 5.4.4 Chokers

Long blocks can lead to high-traffic speeds as vehicles have longer travel distances between intersections. Traffic speeds can be reduced through mid-block neckdowns or “pinch-points,” which are mid-block bulb-outs that physically and visually narrow the roadway (**Figure 5.4-3**). They can add also public space to the sidewalk realm by allowing for additional landscaping/streetscaping.

Mid-block chokers (**Figure 5.4-4**) are mid-block curb extensions placed opposite each other to physically narrow the roadway, forcing motorists to reduce speed and yield to oncoming traffic to pass before proceeding.

#### Design Considerations

- Device is permissible on streets with posted speed of 30 mph or less.
- Device requires curb and gutter and must accommodate drainage.
- Location shall be installed in coordination with the City Street Light Policy.
- Should not be placed within driveways or near community mailboxes (at least 10' from the transition); chokers should be placed in open space areas.
- Device must be at least 500' from any other traffic calming device.
- Device must be placed at least 200' from a traffic control device.
- No parking shall be allowed within the limits of the choker.
- Bike lanes shall be accommodated in the design when built on a collector street; choker must be directly adjacent to the travel lane.



*Source:* <https://nacto.org/publication/urban-street-design-guide/street-design-elements/curb-extensions/>

*Figure 5.4-3 Mid-Block Choker Examples*

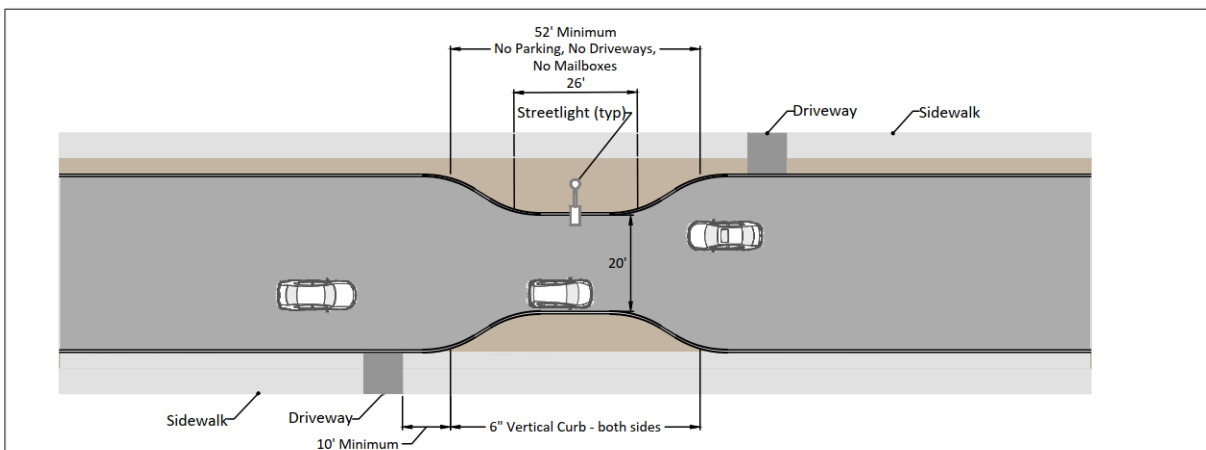

*Figure 5.4-4 Choker*

### 5.4.5 Center Islands

Center islands (**Figure 5.4-5**) are short medians placed in the center of the street at mid-block or at uncontrolled intersections to narrow motor vehicle lanes and create a small shift in the path of travel for roadway users. Center islands reduce street width from the middle rather than from the edges, encouraging vehicles to reduce speeds. Center islands can be designed in a circular shape “baseball” configuration (**Figure 5.4-6**) or an elongated shape “football” configuration (**Figure 5.4-7**).

Center medians may provide the opportunity to add landscaping and aesthetic features. A private maintenance agreement will be required for special treatment proposed within the island. Landscaping and planting will be required to meet visibility requirements.

#### Design Considerations

- Device is permissible on streets with posted speed of 30 mph or less.
- Drainage must be accommodated within the device.
- Manholes valves, and fire hydrants should not be located within the traffic circle.
- The center island location shall be installed in coordination with the City Street Light Policy.
- No driveways, parking, or community mailboxes are allowed within the center island area.
- Device must be placed at least 300’ from nearest traffic calming device.
- Device requires curb and gutter.
- Installation requires approval from the City of Phoenix Fire Department and Valley Metro (if on a transit route); mountable curb may be necessitated to accommodate fire and transit.
- Bike lanes will be accommodated in the design when built along a collector street.



*Center Island*

Figure 5.4-5 Center Island

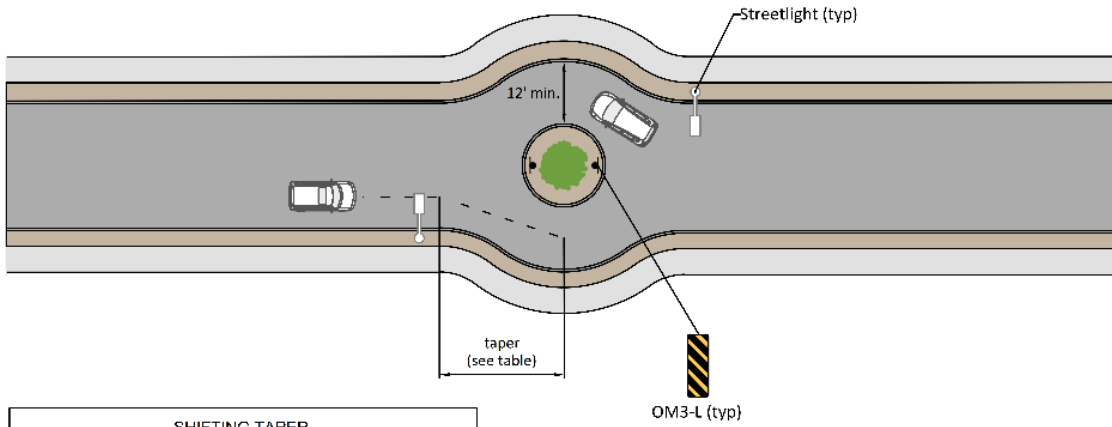

SHIFTING TAPER		
PREFERRED*	3:1	200 SQ. FT. ISLAND
MINIMUM	7:1	50 SQ. FT. ISLAND

\*ACCEPTABLE IN CONSTRAINED CONDITIONS WHERE ANTICIPATED OPERATING SPEED IS  $\leq$  13 MPH.  
SEE MUTCD SECTION 6C.08 FOR SHIFTING TAPER EQUATION TO DETERMINE APPROPRIATE TAPER WHERE OPERATING SPEED IS ANTICIPATED TO BE  $>$ 20 MPH.

Figure 5.4-6 Center Island, Baseball Configuration

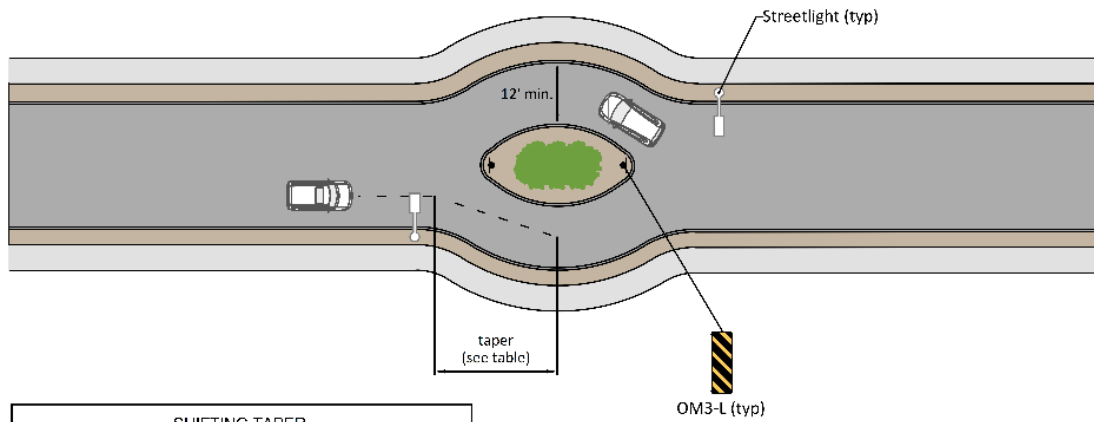

SHIFTING TAPER		
PREFERRED*	3:1	~350 SQ. FT. ISLAND
MINIMUM	7:1	~90 SQ. FT. ISLAND

\*ACCEPTABLE IN CONSTRAINED CONDITIONS WHERE ANTICIPATED OPERATING SPEED IS  $\leq$  13 MPH.  
SEE MUTCD SECTION 6C.08 FOR SHIFTING TAPER EQUATION TO DETERMINE APPROPRIATE TAPER WHERE OPERATING SPEED IS ANTICIPATED TO BE  $>$ 20 MPH.

Figure 5.4-7 Center Island, Football Configuration

### 5.4.6 T-Intersection Bulb-Out

Intersection bulb-outs calm traffic physically and visually by narrowing the street by extending the curb and sidewalk into the intersection, typically where a parking lane ends at an intersection.

Intersection bulb-outs are acceptable traffic calming for compliance with City of Phoenix Zoning Ordinance, Chapter 5, Section 507 TAB A, if the total length of the tangent is at least 25' with a minimum of 10' for one side of the intersection, as illustrated in **Figure 5.4-8**. The intersection shall meet the turning radius for a BU-40 school bus. The pedestrian crosswalk shall be accommodated in the bulb-out section.

#### Design Considerations

- Curb extensions tighten intersection curb radii and encourage slower turning speeds.
- The design of curb bulbs shall not reduce the resulting width of the traveled way below the requirement for the street type.
- Device is permissible on streets with posted speed of 30 mph or less.
- No parking is allowed within 30' from the device.
- Device requires curb and gutter; drainage and drainage inlets must be evaluated due to possible gutter realignment.
- Where application of a curb extension adversely impacts drainage, curb extensions may be designed as edge islands with a 1–2' gap from the curb or a trench drain.
- Typical device offset from travel lane at least 1.5'.
- Device should not extend into bicycle lanes.
- Landscaping should maintain visibility for intersection.

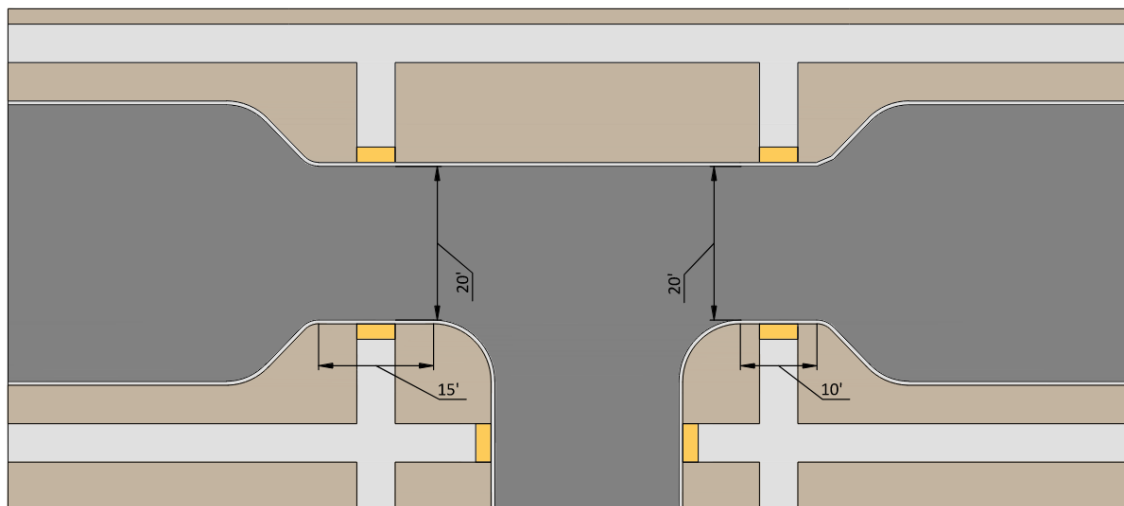

Figure 5.4-8 T-Intersection Bulb-Out

### 5.4.7 Neighborhood Traffic Circles

Traffic circles (**Figure 5.4-9**) replace stop signs at low volume, low-speed intersections (local streets). Neighborhood traffic circles slow traffic by requiring cars to deflect slightly as they travel through the



intersection. Neighborhood traffic circles are different than roundabouts. Neighborhood traffic circles are used for traffic calming purposes on local streets with low traffic volumes in residential areas and can include stop signs or yield signs. Neighborhood traffic circles are typically 20'-25' in diameter, much smaller than a single-land roundabout which may have a center island with a diameter of 75' or more. See **Section 2.8** for more information on roundabouts. The neighborhood traffic circle is designed to slow passenger vehicles, while still allowing occasional access for larger vehicles. The circle may be designed to be fully mountable for larger vehicles.

### Design Considerations

- Traffic circle diameter should be large enough to slow a vehicle. Traffic circles placed at local/local intersections will typically have a central island of 20' to 25'. The circulating roadway is typically 20' from face of curb to face of curb.
- The design speed is 20 mph.
- Traffic circles shall be designed to not impede emergency vehicles.
- Traffic circles may incorporate green storm water infrastructure to optimize aesthetics.



*Figure 5.4-9 Neighborhood Traffic Circle*

## 5.5 MAINTENANCE

Landscaping on traffic circles, chokers, and other traffic calming devices must meet City guidelines and is maintained by the Homeowner's Association. If there is no Homeowner's Association, typically decomposed granite is used. For further information, contact the City of Phoenix Street Maintenance Department, 602-262-6441.

# 6. ACCESS MANAGEMENT

## OVERVIEW

Chapter 6 provides guidance related to access management, the proactive management of vehicular access points to land parcels adjacent to roadways, to promote safe and efficient use of the roadways.



# Chapter 6 --- ACCESS MANAGEMENT

## 6.1 INTRODUCTION

Access management is the proactive management of vehicular access points to land parcels adjacent to roadways, to promote safe and efficient use of the roadways. Access management techniques include:

- Managing spacing between intersections.
- Managing number of and spacing between driveways.
- Providing left- and right-turn lanes.
- Constructing raised medians with appropriately spaced median openings.

Inadequate access management can result in inefficient traffic operations from blocked movements into and out of driveways, increased number of rear-end crashes, conflicting and confusing turns at intersections, and insufficient distance for vehicle maneuvers.

Access management principles are based on the relationship of functional classification of the roadway, to mobility and access. Functional classification of roads in City of Phoenix are described in *Street Classification Map*<sup>6</sup>. The relationship between access, mobility, and functional classification is shown in **Figure 6.1-1**. A local street provides access to adjacent land. Collectors and arterials balance access with the mobility needs of the traveling public. Freeways are fully access controlled and do not provide direct access to adjacent land.

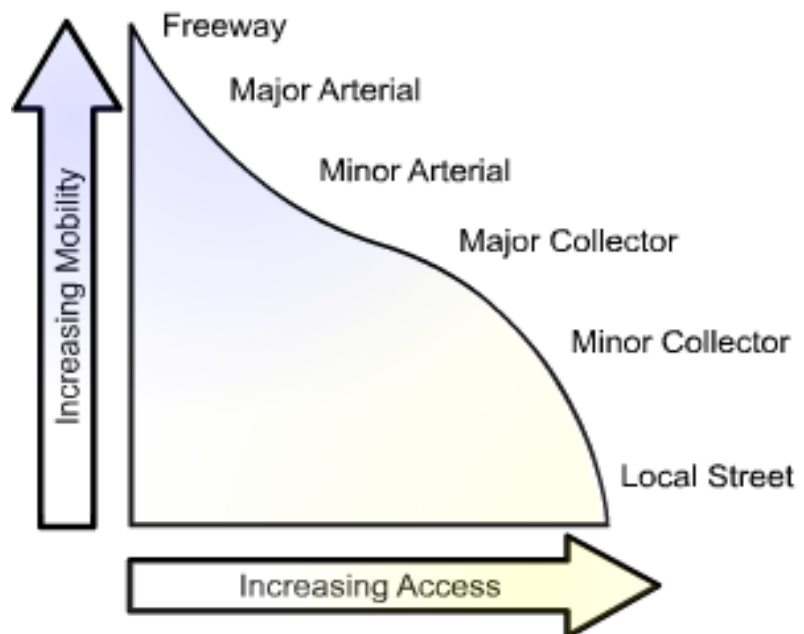

Source: [https://ops.fhwa.dot.gov/access\\_mgmt/what\\_is\\_accsmgmt.htm](https://ops.fhwa.dot.gov/access_mgmt/what_is_accsmgmt.htm)

Figure 6.1-1 Mobility and Functional Classification

## 6.2 GREENFIELD VS. EXISTING/ REDEVELOPMENT

The access guidelines presented in this chapter represent the desired condition for new roadways in new developments. When redevelopment is requested of existing parcels connecting to existing streets, the Applicant will strive to achieve the desired condition to the extent feasible. All signals, driveway locations, and access control that varies from these guidelines will be reviewed for safety and the

<sup>6</sup> <https://www.phoenix.gov/streetssite/Documents/098996.pdf>

surrounding context. Deviation from these guidelines requires consultation and approval by the Street Transportation Department.

Large projects (TIA Category I to IV, as defined in **Table 9.2-1, Chapter 9**) requesting access to arterials will evaluate driveway locations, including a Level-of-Service analysis, in a Traffic Impact Study.

## 6.3 EXTERNAL AGENCY COORDINATION

### 6.3.1 Arizona Department of Transportation

Development within ¼-mile of an ADOT controlled facility requires notification to ADOT through a Red Border Letter submission. Development projects will be required to modify their design plans based upon ADOT stipulations within their right-of-way or access control limits prior to plan submittal and approval by the City.

Refer to ADOT's Roadway Design Guidelines for access control policies relative to ADOT jurisdiction.

Figure 506A stipulates access control within the vicinity of an interchange.

**Traffic Signals:** Proposed traffic signals within a ½ mile of an ADOT facility require the review of ADOT prior to City approval of an associated signal warrant analysis. Traffic signals located within ADOT controlled right-of-way or limits of control requires ADOT approval.

**Driveway Location:** Access proposed within ADOT's right-of-way or access control limits require ADOT approval prior to plan approvals by the City.

Traffic signal and access control within or adjacent to ADOT facilities shall follow the *ADOT 2021 Roadway Design Manual, Section 104 – Control of Access*.

### 6.3.2 Adjacent Municipality or Entity

Access control, traffic signalization, and/or infrastructure improvements to non-City controlled right-of-way requires the documentation of approval be presented from the affected jurisdiction or entity prior to plan approvals by the City.

## 6.4 ACCESS MANAGEMENT SUMMARY

### 6.4.1 Disclaimer

The City has the right to change or remove access as necessary, as specified in City Code Section 31-43.

*“Provision may be made by the City for vehicular access to private property from streets and alleys, but in so doing due consideration must be given to pedestrian and vehicle safety, the resulting interference with the movement of vehicular traffic, and interference with public improvements. In establishing permissible curb cuts and sidewalk driveway crossings for access to private property, authorization shall not be granted where they are unnecessary or where they would unreasonably interfere with the rights of the public in the adjacent street or alley, and in no event shall any such cut or crossing be of greater width than necessary for reasonable access to the private property to be served thereby. (Code 1962, § 35-55)”*

### 6.4.2 Authority of Street Transportation Director

City of Phoenix Code 31-44 designates the duty of the Street Transportation Director to authorize new driveway connections to City streets.

City of Phoenix Code 31-49 directs the removal of driveway connections for those that are not needed when a land use changes.

### 6.4.3 Access Management Guidelines Summary

The spacing and location of intersections, median openings, and driveways is critical to public safety. Their location must balance access to adjacent land uses with the capacity and traffic flow impacts to the roadway.

Access spacing requirements for signalized intersections, median opening, and driveways by street classification, are summarized in **Table 6.4-1**.

Table 6.4-1 Signalized and Unsignalized Intersection and Access Spacing Summary

	Major Arterials	Arterials	Collector	Minor Collector	Local
<b>Signalized Intersections</b>					
<i>Downtown Core and Walkable Urban Areas</i>	Per warrant analysis and approval from the Street Transportation Department				
<i>Urban, Suburban, spacing in areas of significant density permitted as outlined in Section 6.5.2.</i>	1-mile desirable, ½ mile minimum spacing	1-mile desirable, ½ mile minimum spacing	½ mile	½ mile	N/A
<i>Rural</i>	1-mile	1-mile	N/A	N/A	N/A
<b>Unsignalized Median Opening Spacing</b>					
<i>Downtown Core and Walkable Urban Areas</i>	Per Downtown Code and Walkable Urban Code, as applicable and approval from the Street Transportation Department				
<i>Residential, Industrial, Suburban Commuter Center</i>	660' intervals	660' intervals	660' intervals	N/A	N/A
<i>Rural</i>	660' intervals	660' intervals	660' intervals	N/A	N/A
<b>Unsignalized Driveways and Corner Clearance Spacing</b>					
<i>Divided Roadways</i>	150'	150'	100'	N/A	-
<i>Undivided Roadways</i>	300'	300'	150'	100'	-
<b>Signalized Intersection Corner Clearance Spacing</b>					
<i>Divided Roadways, See Table 6.7-1</i>	175-275' upstream, 360' downstream		175' upstream, 250' downstream		-
<i>Undivided Roadways</i>	360'	360'	250'	250'	-

## 6.5 SIGNALIZED INTERSECTIONS

### 6.5.1 Signalized Intersection Spacing

Traffic signals must meet warrants per the MUTCD. In the City of Phoenix, the typical spacing between signalized intersections is at ½-mile intervals. This spacing typically occurs at the intersection of arterial and collector streets. This spacing facilitates two-way signal coordination for traffic speeds of 35-45 mph.<sup>7</sup>

<sup>7</sup> Transportation Research Board Access Management Manual, Second Edition, 2014, page 360

### 6.5.2 Urban, Downtown Core, and Walkable Urban Areas

In urban or core areas, as well as other unique situations, the Street Transportation Department may consider signals at other spacing intervals as demonstrated through a signal warrant analysis or existing planning document (Downtown Transportation Study) identifying future signalized intersections. Alternative locations must be approved by the Street Transportation Department and demonstrated by an engineering analysis.

### 6.5.3 Signalized Access to Private Development

Signalized access to private development requires a higher level of design to accommodate traffic signal equipment and lane configurations. This may require additional right-of-way or additional easements to provide appropriate signal spacing. The intersection should be designed to a typical public street intersection for roadway design and ADA compliance, winged type driveways will not be allowed on the private side access unless approved by the Street Transportation Department.

Traffic signals proposed by private development projects must meet warrants per the MUTCD, as reviewed and approved through the Traffic Impact Study procedures and must be approved by the Street Transportation Department.

## 6.6 UNSIGNALIZED MEDIAN OPENINGS

Median island openings on arterials and collectors will be allowed at no less than 660-foot intervals. Openings other than at the 660' locations may be permitted if approved by the Street Transportation Department. Deviation may be considered based upon demonstrating the following:

- Does not create a conflict or negatively affect neighboring properties and future access control at appropriate spacing.
- Promotes cross access for adjoining uses.
- Site does not have frontage on any other public street providing access to the site.
- Does not conflict with any corridor specific roadway and landscaping plan.

Median openings may consist of full-median openings (left-in/left-out), or partial-median openings with left-turn restrictions.

## 6.7 DRIVEWAYS

### 6.7.1 Spacing

The distance between adjacent driveways must be sufficient to allow driveway vehicles to safely queue, accelerate, decelerate, and cross conflicting traffic streams, without excessive interference with through traffic or traffic using adjacent driveways.

Driveway spacing requirements (**Table 6.4-1**) are also reviewed in the context of the roadway and right-of-way, the size and location of parcels under development, and existing traffic control and safety mitigations.

### 6.7.2 Driveways Frequency and Location

In compliance with the City of Phoenix Complete Street Ordinance, driveways should be minimized to reduce pedestrian conflicts and support multimodal enhancements of the street. Multiple driveways

create additional vehicular conflict points and degrade the overall performance of the through street.

Generally, lots not associated with a larger development or subdivision process will be minimally allowed a single right-in, right-out drive access to a public street. There is no assurance of a full-access driveway. New developments that establish multiple parcels shall provide cross access between parcels to minimize the number of driveways to the street and meet the applicable spacing requirements.

For development over 2,000 SF of building footprint, a Street Transportation review is typically triggered and will provide the Planning & Development Department documentation and review comments regarding access.

Existing, unused driveways must be replaced with curb, gutter and sidewalk constructed to City standards, consistent with City Code 43-49.

### **Downtown Core and Walkable Urban Areas**

Driveway locations in the downtown core and urban neighborhoods in proximity to light rail are governed for driveway size and location by the Downtown Code, Walkable Urban Code, and Transit Overlay District areas.

### **Local /Collector Street Frontage**

Zoning Ordinance 507 Tab A 6.3.1 directs that non-residential land uses should not be permitted to access local or collector streets if adequate access is available to arterial streets.

If necessary, a restricted-access driveway contravening the requirements for local or collector street access shall be requested to the Planning and Development Department. The applicant will need to overcome the presumption and demonstrate no negative effect on surrounding properties for consideration.

### **Residential Access**

There should be no direct residential lot access to arterials. Direct residential lot access to collectors should be avoided in new Subdivision designs. Direct access may be considered by the Street Transportation Department on a case-by-case basis if arterial or collector access is the only available street frontage.

### **6.7.3 Alignment**

Proposed driveways should align with any existing driveways on the opposite side of the roadway to reduce conflicts. If conditions prevent alignment and require offset driveways to be constructed, the left-turn movements should not overlap each other. Offset driveways shall be designed so the left-turn movements do not share the same space in existing or future two-way left-turn lane or left-turn pocket or otherwise interfere or create conflicts with intersecting street intersections.

### **Divided Roadways**

Access points at full median openings should align or be offset by the limits of the left-turn lane striping or the driveway spacing requirement, whichever is greater, as outlined in **Table 6.4-1** and **Figure 6.7-1**.

Increased distance may be required to accommodate vehicle storage requirements, as analyzed in a Traffic Impact Study. If the noted design requirements for driveway locations cannot be met, then driveway turning movement restrictions may be imposed. Cross-access or shared access should be obtained where possible.

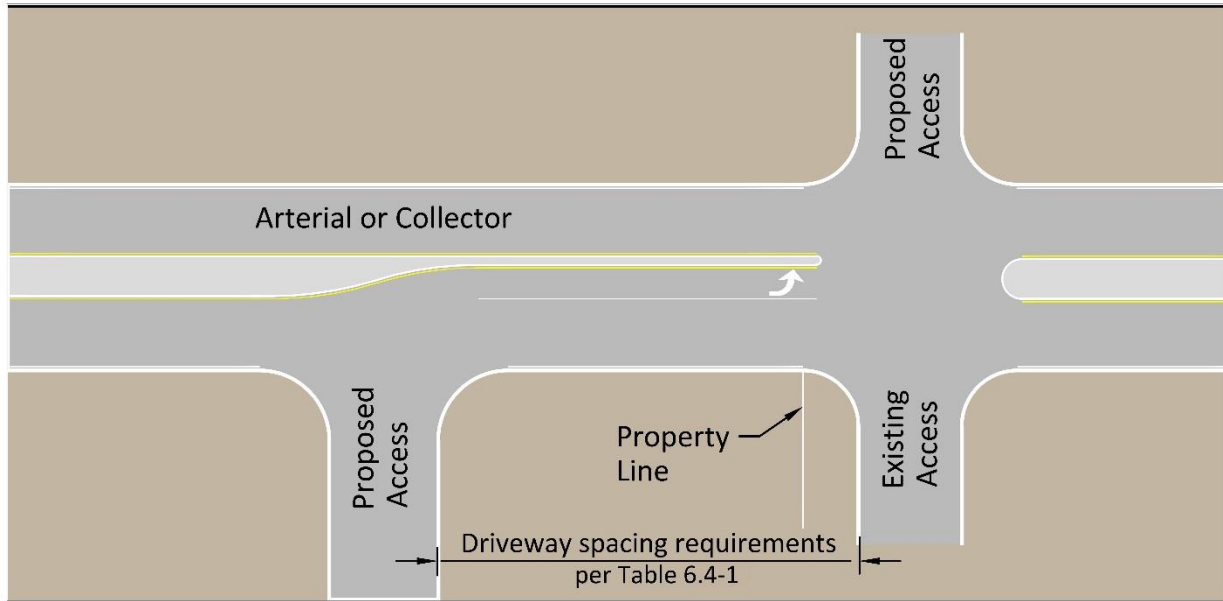

Figure 6.7-1 Divided Roadway, 150' Offset Driveway Locations – Median Opening

### Undivided Roadways

On undivided arterial and collector roadways, the access points on both sides of the roadway should align or be offset by 300' for arterials, and 150' for collectors (**Figure 6.7-2**), as measured from edge of asphalt to edge of asphalt. If the noted design requirements for driveway locations cannot be met, then driveway turning movement restrictions may be imposed.

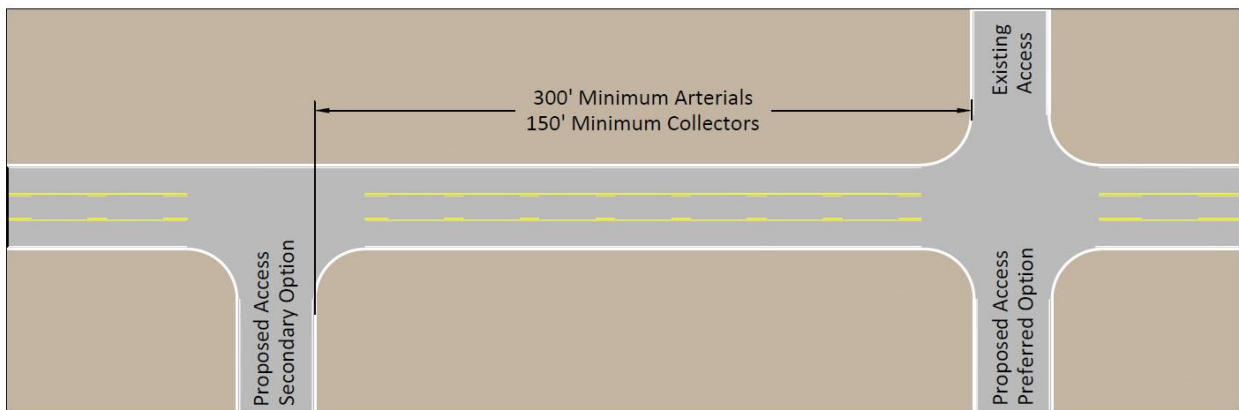

Figure 6.7-2 Undivided Roadway

### 6.7.4 Corner Clearance

Driveways to corner lots should be located as far away from the intersection as practical. Driveways located near a signalized intersection along a street are to meet the minimum corner clearance requirements shown in **Table 6.7-1** and **Figure 6.7-3**. Distances are the minimum clear distance between the face of curb and the edge of the driveway.



Table 6.7-1 Driveway Corner Clearance (Signalized Intersections)

Distance	Corner Clearance Distance	
	Arterials, Major Arterials (ft)	Collector, Minor Collector (ft)
A	360	250
B	175-275 <sup>1</sup>	175 <sup>1</sup>
C	360	250
D	360	250

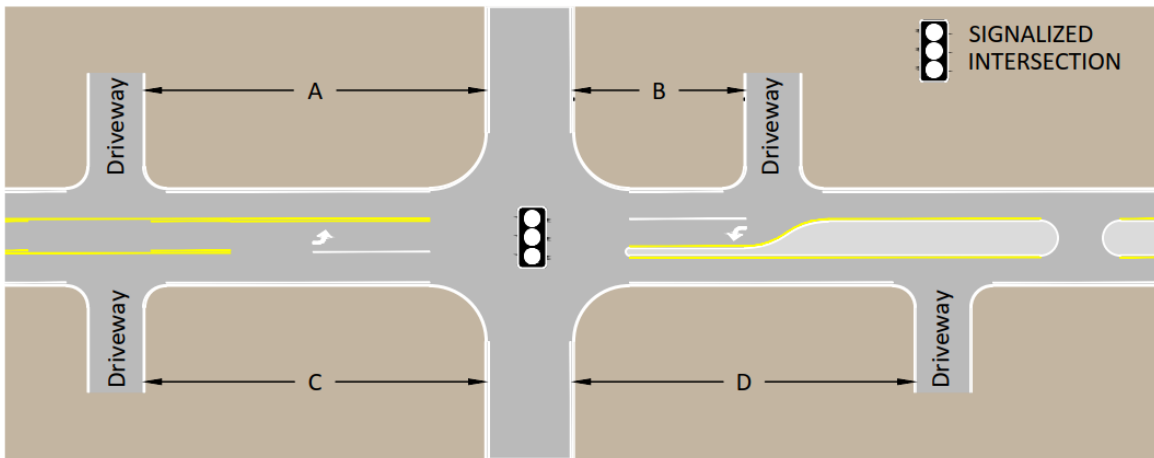

**Note 1:** Distance shall be no less than the length of the left-turn storage lane.

Figure 6.7-3 Corner Clearance

### 6.7.5 Non-Greenfield/Existing Constrained Environment

Arterial and collector roadways in established parts of the City, are frequently defined by small parcels with access driveways in close spacing. It may not be possible to constrain access locations to desired minimum spacing. The following considerations shall apply in order listed to determine site access:

- Establish and utilize cross-access to existing driveways on neighboring sites.
- Installation of right-in/right-out restricted driveways (per the P1243 standards series).
- Utilization of paint and sign alternatives for restriction of directional access.
- Notation of site plan establishing future access restrictions in the event of City safety improvement, such as median installation.
- The safety of the traveling public is paramount.
- For any lot with less than 300' of street frontage, the driveway shall be placed as far from the nearest street intersection as possible. Driveway access locations within 150' of an arterial intersection, or 100' of a collector intersection, require documented approval by the Street Transportation Department.

### 6.7.6 Driveway Width

**Table 6.7-2** identifies driveway entrance widths for driveway types and land uses consistent with current City of Phoenix Standard Detail.

Wing type driveways will be the standard driveway type unless the need for a return type driveway is proven and approved by the Street Transportation Department. The top of wings for driveways should be located a minimum of 2'6" from the property line. Radius-return driveways will be considered on arterials and collectors with a speed limit of 45 mph or greater at high-turnover sites or sites with high truck volume. Pedestrian safety is paramount.

A minimum 36" clear accessible walkway must be provided around the perimeter of all driveways to provide a maximum cross slope of 2 percent MAX.

Table 6.7-2 Driveway Width

Street Classification	Type of Development				
	Single Family	Multi-Family/Commercial		Gas Station	Truck Facilities
		<30 Spaces	>30 Spaces		
<i>Alley</i>	16' Minimum	20'	20'	-	-
<i>Local Residential</i>	12' One Car 16' One Car – Recommended	24'-30'	30'	-	-
<i>Local Commercial/Industrial</i>	-	30' – 40' **	30' – 40' **	40' **	40' – 50' **
<i>Collector Residential</i>	16' Minimum	30' **	30' **	40' **	-
<i>Collector Commercial/Industrial</i>	-	30' – 40' **	30' – 50' **	40' – 50' **	40' – 50' **
<i>Arterial</i>	Discouraged except for large lot-circular drives*	30' **	40' **	40' – 50' **	40' – 50' **

Source: City of Phoenix Supplemental Standard Detail P1255-4 Driveway Widths Policy

\*Minimum 82' property width.

\*\*Median -30' Maximum unless there is significant truck access, then 40'.

### 6.7.7 One-Way Driveways

One-way directional driveways “In or Out” are discouraged to/from public streets. Allowance may be considered for sites that have existing constraints, such as existing buildings on a lot with constrained widths, or other existing non-site development induced constraints. Allowance shall require the approval of the street transportation department. The development will be responsible for installation and maintenance of all associated on-site directional signage and markings.

For one-way driveways the width shall be 24' for entrance-only driveways on all streets, 16' for exit-only driveways on local or collector streets, and 20' for exit-only driveways on arterial streets.

### 6.7.8 Cross Access and Common Driveway

Cross access is achieved when property owners agree to allow vehicles traveling to adjacent parcels to cross their property to access a driveway access point.

Common driveway access is achieved when adjacent property owners agree to share a single driveway that is located on the property line (half of the driveway on each parcel).

On major arterial and arterial streets, the sharing of driveways between adjacent properties and common ingress/egress easements is encouraged. New development creating multiple parcels or projects that seek to split lots shall require cross access between parcels to minimize the number of driveways connections to the street.

The City of Phoenix Planning and Development Department has developed a checklist for a cross access/common driveway/cross parking agreement, which is used when adjacent properties desire, or are required to, provide non-exclusive access (for vehicles and pedestrians) to driveways, maneuvering areas, and parking areas ([https://www.phoenix.gov/pddsite/Documents/TRT/dsd\\_trt\\_pdf\\_00407c.pdf](https://www.phoenix.gov/pddsite/Documents/TRT/dsd_trt_pdf_00407c.pdf)).

### 6.7.9 Light Rail Corridors

The following design considerations must be made throughout all Phoenix light rail corridors:

- Curb returns and driveways must be designed to minimize large truck and bus turning movement encroachments onto the guideway curb and trackway, where applicable. Fences, signs, and poles, etc. must be set back far enough to minimize large vehicle maneuvers onto the trackway area. A truck turning analysis may be required to demonstrate safe maneuvers into and out of driveways.
- Vehicular access will not be allowed across the trackway except at traffic signal locations. Non-signalized driveways and cross-streets will be right-in/right-out and will not cross the rail line unless specifically permitted by roadway signage and striping.

## 6.8 AUXILIARY TURN LANES

### 6.8.1 Right-Turn Lanes

Right-turn/deceleration lanes may be required at driveways to assist traffic exiting the roadway. The need for right-turn lanes to developments are based on criteria that consider traffic volume and street cross section as identified in **Table 6.8-1**.

Street Transportation Department will indicate installation requirements based on the recommendations in consideration of the site context.

No driveways are to be located within the limits of deceleration lanes. Deceleration lanes will be constructed to serve individual driveways. No continuous deceleration lanes will be allowed to serve multiple driveways. Dimensions of storage and taper lengths for right-turn lanes is described in Chapter 2, Section 2.3.6.

Table 6.8-1 Site Driveways Turn Lane Criteria

Driveway Auxiliary Lane	Arterial and Collector Roadway	Industrial/Freight Development
<p><b>Driveway Right-Turn Lane/Deceleration Lanes</b></p>	<p>Driveway right-turn lane is to be provided when:</p> <ul style="list-style-type: none"> <li>▶ The outside/curb lane has an expected volume of 250 vph or greater and the right-turn volume is greater than 55 vph.</li> </ul> <p>Or, when 3 of the following are met:</p> <ul style="list-style-type: none"> <li>▶ 5,000 vehicles per day on the adjacent street.</li> <li>▶ Posted speed limit is greater than 35 mph.</li> <li>▶ 1,000 vehicles per day are expected to use the driveway.</li> <li>▶ At least 30 vehicles are expected to make right-turns into the driveway within a one-hour period.</li> </ul> <p>Driveway right-turn lane/deceleration lanes may be required on interim-condition arterial roads that are not yet currently built to the ultimate cross section.</p>	<p>For large industrial or commercial developments with a significant percentage of truck traffic entering the site from a high-volume arterial, driveway right-turn deceleration lanes may be required at the below described criteria and will be evaluated on a case-by-case basis.</p> <p>Auxiliary lanes will be required for all sites with 25 or more truck bays at all primary entrance route driveways.</p>

### 6.8.2 Left-Turn Lanes

Traffic volume warrants for adding a left-turn lane to a roadway that a two-way left turn lane is not present are shown in **Table 6.8-2**. The volumes provided in **Table 6.8-2** are the minimum left-turn peak-hour volume and minimum through volume in the same direction. A left-turn lane will be required if the left-turn peak-hour volume is equal to or greater than the volume shown in **Table 6.8-2**.

Dimensions of storage and taper lengths for left-turn lanes is described in **Chapter 2, Section 2.3.6**.

Table 6.8-2 Volume Warrants for Auxiliary Left-Turn Lanes

Peak Hour Traffic Volume on the Roadway in the Advancing Direction	Minimum Peak Hour Left-Turn Traffic Volume			
	Number of Through Lanes Per Direction			
	1		2	
	< 45 MPH Posted Speed	≥ 45 MPH Posted Speed	< 45 MPH Posted Speed	≥ 45 MPH Posted Speed
≤ 200	30	15	-	-
201-300	12	12	40	30
301-400	12	12	30	25
401-500	12	12	25	18
501-600	12	12	15	12
601-1000	12	12	10	8
1001+	12	8	10	8

Source: MCDOT Roadway Design Manual, p. 7-19

### 6.8.3 Angle of Entry/Exit and Driveway Throat Length

The preferred driveway angle of entry and exit is 90 degrees. Up to 15 degrees deviation is permissible. The driveway throat should be of sufficient length to enable the intersection of the driveway and abutting roadway and the on-site circulation to function without interference with each other. Drivers

entering the site should be able to clear the intersection of the roadway and the driveway before encountering any on-site intersections. Driveway throat length is a minimum 60' (three car lengths) but could require longer lengths considering on-site circulation. On-site driveway aisle to a driveway to be a minimum 3:1 taper.

#### 6.8.4 Driveway Sight Visibility Triangle

Single-family residential driveways should not be located within the curb radius return on a corner lot. A 10' by 20' sight visibility triangle is required on both sides of a driveway as illustrated in **Figure 6.8.1**. If a property has 10' of right of way behind the curb, then the sight visibility triangle could be measured 7' from back of curb.

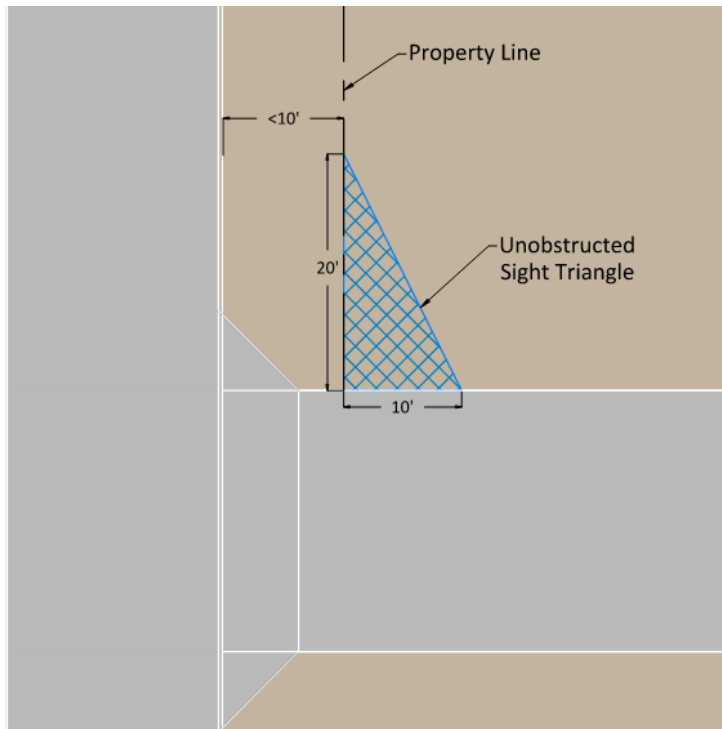

Figure 6.8-1 Driveway Sight Visibility Triangle

31-13 depicts the method used to determine the sight triangle as measured along the property line, as illustrated in **Figure 6.8-2**.

If a property has 10' or more of right-of-way behind the curb, then the sight visibility triangle could be measured 7' from back of curb as illustrated in **Figure 6.8-3** and **Table 6.8-3**.

#### 6.8.5 Intersection Sight Visibility Triangle

Sight visibility triangles shall be used to limit the height of structures, vegetation, and other improvements on corner properties immediately adjacent to intersections.

Visibility triangles are not to be used as a substitute for intersection sight distance.

Visibility triangles provide visibility around corners for all intersection approaches and should be applied to the design of perimeter walls and landscape features. Items within the triangle shall be no higher than 36" measured from the roadway surface. City Ordinance

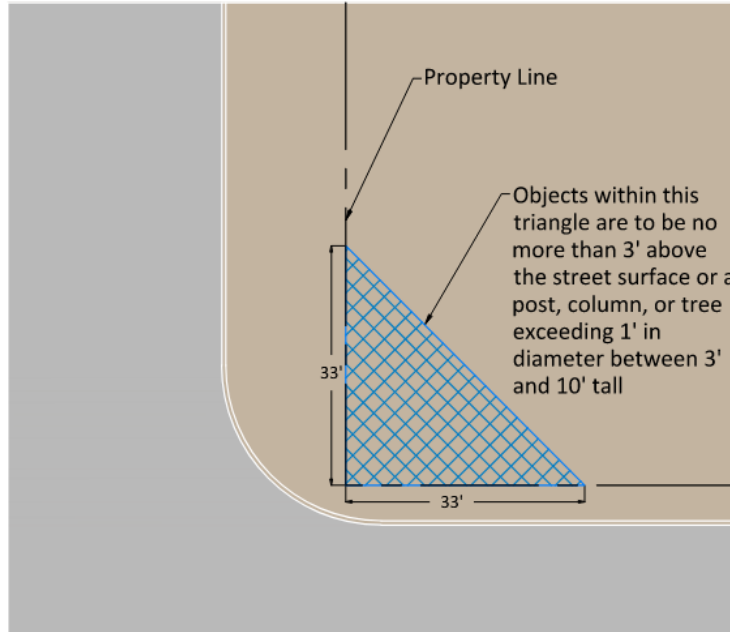

Figure 6.8-2 Street Intersection Sight Visibility Triangle

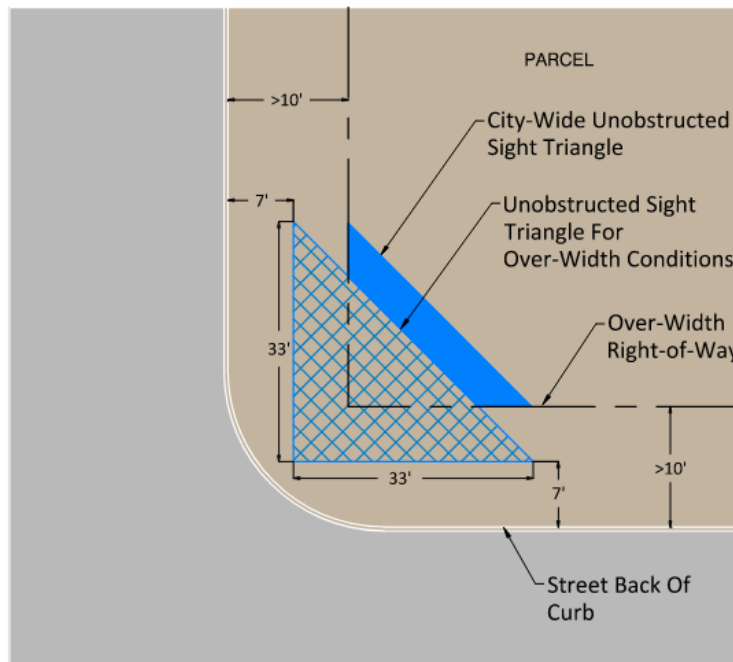

Figure 6.8-3 Street Intersection Alternative Sight Visibility Triangle

**Sec. 31-13. OBSTRUCTING VISIBILITY AT INTERSECTIONS.**

At public street intersections in residential areas, there shall be no fence or wall or hedge higher than 3', nor any obstruction to vision other than a post or column or tree not exceeding 1' in diameter between a height of 3' and 10' inside the triangular area formed by the lot lines at the following distances from the point of their intersection.

Table 6.8-3 Street Intersection Sight Visibility Triangle

Classification of Intersecting Street	Distance Measured Along Each Street
Local-Local	33'
Local-Collector	33'
Collector-Collector	33'
Collector-Arterial	33'
Arterial-Arterial	33'
Arterial-Local	33' along arterial street 15' along local street

In non-residential areas, the above provisions for unobstructed sight triangles on private property apply only to landscaping.

### 6.8.6 Turn Restrictions

Where full access will impact the safety along the adjacent roadway, turning restrictions at driveways may be implemented. The restriction may be for left-turn movements in or out of the driveway, which is a right-in, right-out driveway.

Turning restrictions should be imposed for driveways that are too close to signalized intersections, or where existing driveways or roadway characteristics may increase crash potential or at locations with a history of high-crash rates. **Figure 6.8-4** provides examples of turning movements restrictions. Signage identifying the movement restrictions shall be installed in the median per current MUTCD standards.

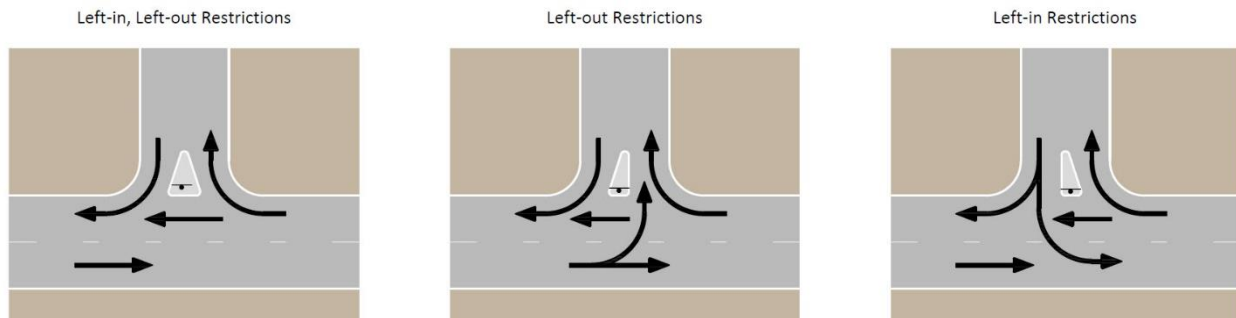

Figure 6.8-4 Examples of Turn Restrictions

### 6.8.7 Alleys

Alley access shall be provided where required by applicable City Ordinance. The Driveway Ordinance prohibits access from commercial property to alleys that abut residential property. Commercial access to residential alleys not permitted by City Ordinance must be applied for and shall be considered by the Driveway Hearing Officer.

Alleys utilized for site access shall be paved to the nearest cross street. Development located mid-block or fronting 50 percent or more of the block shall be paved to the two nearest intersecting streets to a local street standard.

Vehicular movement shall be contained on-site and not within the alleyway unless approved by Planning Hearing Officer by variance through the Planning and Development Department. Contact the Planning and Development Department for additional information.

## 6.9 DRIVEWAY AND INTERSECTION SPACING NEAR ROUNDABOUTS

Table 6.9-1 presents typical driveway and intersection spacing recommendations at roundabouts on two-lane and four-lane streets.

Table 6.9-1 Minimum Access Connection Spacing from Roundabouts

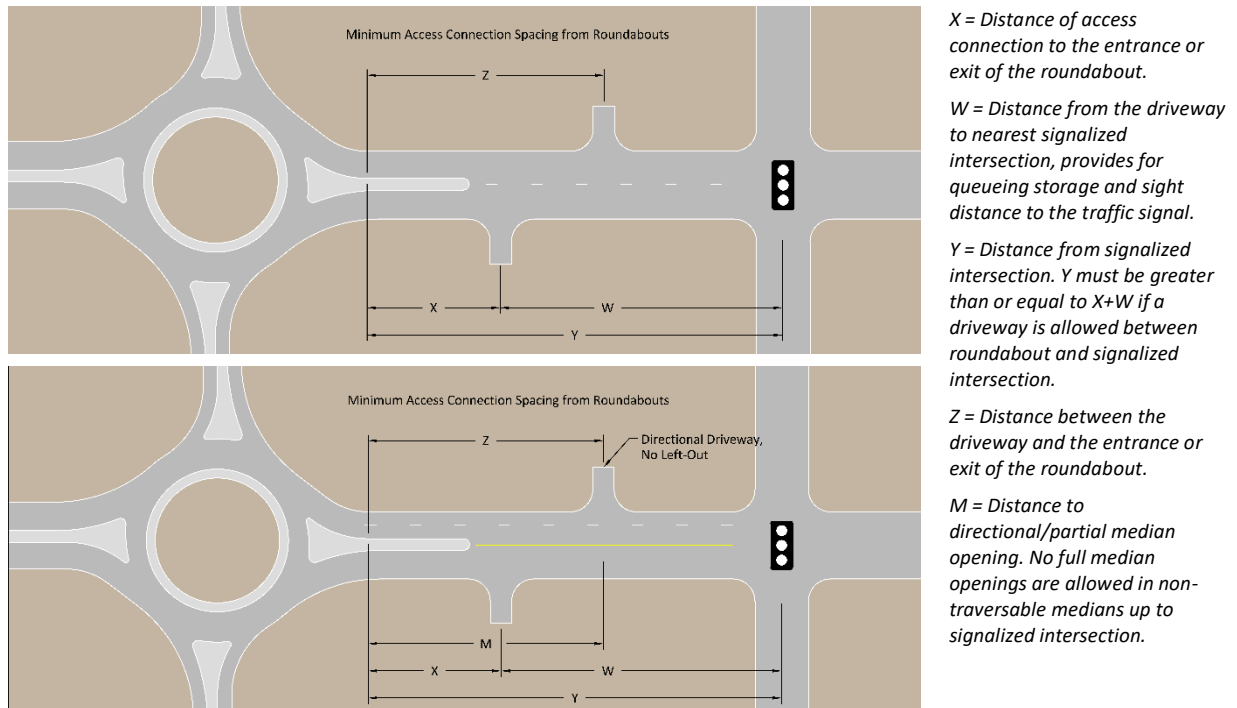

Urban Area		Spacing Dimension (feet)				
Number of lanes	Design Speed (mph)	X	W	Y	Z	M
2-lane	25	400'	1000'	1000'	460'	N/A
	30	490'	1090'	1090'	460'	N/A
	35	590'	1140'	1140'	460'	N/A
4-lane	25	400'	1000'	1000'	510'	475'
	30	490'	1090'	1090'	510'	565'
	35	590'	1140'	1140'	510'	665'

Source: Transportation Research Board Access Management Manual, Second Edition (2014), p. 438

## 6.10 DRIVEWAYS AT BUS BAYS

City of Phoenix Public Transit Department standards and policies dictate placement of bus stops and bus bays. Additional requirements may include enhanced pedestrian infrastructure and shade. Driveways are prohibited within the passenger waiting area of bus stops. Driveways should be located such that bus stop improvements are beyond the projection of driveway visibility triangles and drivers will be able to see around bus stop improvements, both existing and planned. Driveways are not to be located within the flat portion of the bus bay (bus standing area). See City of Phoenix Supplemental Standard Details for Public Works. Contact the Public Transit Department at [pubtrans@phoenix.gov](mailto:pubtrans@phoenix.gov) or 602-262-7242 for more information.



# 7. SUBDIVISION STREET PLANNING



## OVERVIEW

Chapter 7 provides an overview of key requirements and formal interpretations for subdivision street planning and design, such as street location principles, street design guidelines for subdivisions, and block design and connectivity

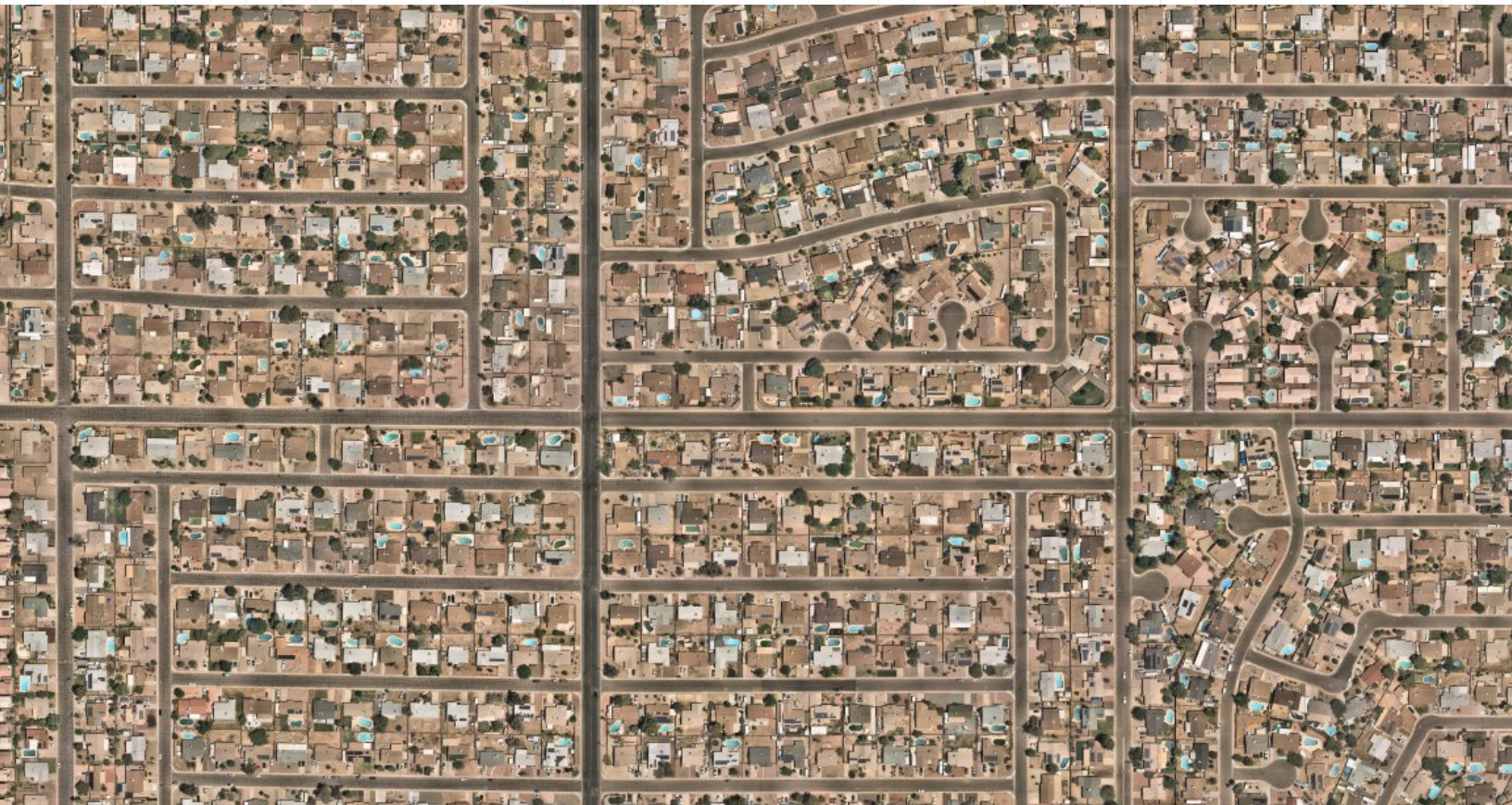

# Chapter 7 --- SUBDIVISION STREET PLANNING

This chapter provides an overview of key requirements and formal interpretations for subdivision street planning and design, such as street location principles, street design guidelines for subdivisions, and block design and connectivity. Requirements for subdivision street planning are contained in Phoenix City Code, Chapter 32 – Subdivisions, as well as applicable sections of Phoenix Zoning Ordinance Sec 507 Tab A. C. Subdivision Design/Development. Further subdivisions shall meet the criteria and intent as outlined in the City of Phoenix adopted Complete Street Guidelines for all-inclusive multimodal design.

General design principles for public and private streets are contained in Chapter 32-25, Design Principles and Development Standards in General, which states:

*Every subdivision shall conform to the requirements and objectives of the City General Plan, or any parts thereof, as adopted by the City Council, to the Zoning Ordinance, the Planning and Development Department Development Review Guidelines, and to other ordinances and regulations of the City, and to the Arizona Revised Statutes.*

The following sections are to be viewed in relation to Chapter 32 of the City Code and Section 507 Tab A of the Phoenix Zoning Ordinance. It is the intent of this section to provide additional commentary, detail, and context sensitivity in providing City direction on subdivision planning and review.

## 7.1 STREET TYPE AND ARRANGEMENT

Street location and arrangement shall be consistent with City Code 32-26, as well as the City's current adopted Street Classification System (1992) Handbook<sup>8,9</sup> and Council adopted specific plans.

### 7.1.1 Local Streets

- Local streets are not intended for regional through traffic; local streets provide internal trips connections to adjacent collector and arterial streets. Traffic volumes should be under 1,000 ADT; 100 vehicles an hour for single family homes, 2,000 ADT; 200 vehicles an hour within more dense developed areas.



Source: planPHX, 2015 General Plan, Adopted April 2018, p. 15.

<sup>8</sup> [https://www.phoenix.gov/pdds/site/Documents/PZ/pdd\\_pz\\_pdf\\_00176.pdf](https://www.phoenix.gov/pdds/site/Documents/PZ/pdd_pz_pdf_00176.pdf)

<sup>9</sup> <https://www.phoenix.gov/streetssite/Documents/098996.pdf>

- Local streets' primary function is to provide direct access to abutting lands and for traffic movements within neighborhoods connecting to localized entities as schools, parks, trailheads, and shopping centers.
- The Street Classification map does not reflect local street locations or alignments.
- Local streets typically shall remain and/or be dedicated as public roadways.

### 7.1.2 Collector Streets

- The Street Classification map may not reflect all collector street locations and alignments. Collector streets are to be designated at the half-mile point east to west and north to south within every quarter section. Consideration can be given to existing topography, wash corridors, and existing street network in identifying its ultimate placement.
- Collector streets' primary function is to collect and distribute traffic between local streets or high-volume traffic generators and arterial streets at evenly disbursed intersections. As such collector streets shall remain and/or be dedicated as public roadways.
- Collector streets placement should reflect existing alignments and be connected and extended in areas where a collector street exists to facilitate network connectivity.
- Traffic volumes for collectors may range between 5,000 to 30,000 ADT dependent on one (1) or two (2) through lanes in each direction.
- Minor residential collector volumes may range between 1,000 to 8,000 ADT with one (1) lane in each direction.
- Single family lots fronting onto a collector street should be avoided. If proposed within a new subdivision, a minimum collector street section shall be provided to allow for on-street parking, separated bicycle lanes and turn lane striping at intersections.

### 7.1.3 Arterial Streets

- Arterial streets shall be dedicated as public streets as their primary function is to collect and disburse regional traffic at evenly disbursed intersections.
- Arterial street placement should reflect existing alignments and be connected and extended in areas where arterial street exists to facilitate network connectivity.
- Arterial street volumes may range between 15,000 to 50,000 ADT with two (2) to three (3) through lanes in each direction.
- Traffic volumes for major arterial streets may range between 30,000 to 60,000 ADT with three (3) lanes, up to four (4) lanes in the transition area where the street serves as an extension of a freeway or expressway in each direction upon build-out.

## 7.2 STREET DESIGN

Street design shall be consistent with City Code 32-25 thru 35 and Sec 507 Tab A. C. Subdivision Design/Development. When connecting into an existing platted subdivision, the requirements of existing City Code and following shall apply.

### 7.2.1 Block Lengths

The City of Phoenix Zoning Ordinance, Chapter 5, Section 507 TAB A, Guidelines for Design Review Part II. C. Subdivision Design/Development, states that “Local streets exceeding 600’ in length should incorporate traffic calming measures.” See Chapter 5 Neighborhood Traffic Calming for approved standards and details to be utilized.

### 7.2.2 Cul-de-Sac Streets

Cul-de-sac streets shall comply with City Code 32-27. In residential subdivisions cul-de-sacs shall terminate in circular right-of-way 50’ in radius with an improved traffic turning circle. A 45’ radius may be used when rolled curb is permitted. When vertical curb is required or where sidewalk is offset, the traffic turning circle shall be a minimum 50’ in radius. City of Phoenix Planning and Development Department may approve an equally convenient form of space where extreme conditions justify.

When a cul-de-sac terminates adjacent to an amenity area or public open space vertical curb should be utilized.

### 7.2.3 Knuckles

Subdivision knuckles (**Figure 7.2-1**) are areas on the roadway expanded to provide a turn-around and additional access or lot frontage on residential-collector and local streets. Knuckles are required at intersections where each street extends in only one direction from the intersection.

Sidewalk ramps are not required at knuckles; however, if they are provided, they should be in accordance with City Standard Details. Ramps should be provided if there are amenities on either side of the “elbow.” Knuckle dimensions are shown in **Figure 7.2-2**. Design shall consider sight visibility when designing the ramp location.



Figure 7.2-1 Neighborhood Street Knuckle

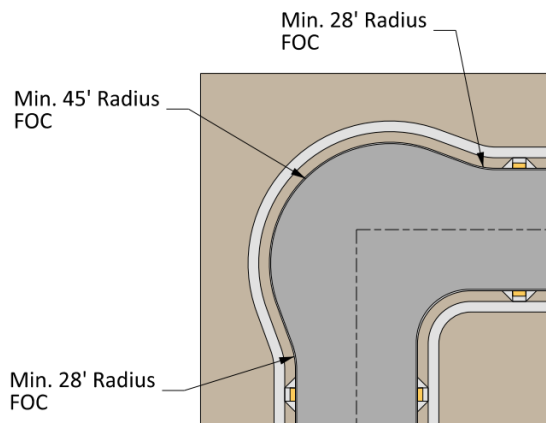

Figure 7.2-2 Subdivision Knuckles

#### NOTES:

1. Alternate knuckle configurations may be used. Alternate design must accommodate a standard City of Phoenix Solid Waste Collection truck, inside wheel track radius of 28.4’ and outside wheel track of 44’, without the truck encroaching on the sidewalk.
2. Alternatives must be approved by Public Works.
3. Knuckles are not required if lots not requiring sanitation pick-up are proposed for the outside of the “elbow.”
4. Pedestrian crossings shown require ramps on both sides of the street.

### 7.2.4 Eyebrows

Eyebrows (**Figure 7.2-3**) are permitted between intersections to improve accessibility to odd-shaped sites. The design of an eyebrow should be in accordance with plans approved by the City of Phoenix Development Services Department.

### 7.2.5 Alleys

Alleys (**Figure 7.2-4**) shall comply with City Code 32-27 and 32-33. When an alley is proposed for site access or utilization for public or private services, the alley pavement structural section shall be paved to a minimum local street standard to the nearest cross street. Development located mid-block or fronting 50 percent or more of the block shall be paved to the two nearest intersecting streets.

### 7.2.6 Residential Subdivision Street Cross Sections

Single-family subdivision local streets requesting detached sidewalks shall be designed to a minimum cross section “H” City Std Detail with a minimum of 32’ of asphalt paving.

Subdivisions utilizing local street cross section City Std detail “I” with detached sidewalks shall be constructed with 6” vertical curb and City standard wing type driveways. Parking may be restricted to one side only.

## 7.3 BLOCK DESIGN

Block Design shall be consistent with City Code 32-28. The maximum length of cul-de-sac streets is 400’, measured from the intersection of right-of-way lines to the extreme depth of the turning circle along the street centerline. An exception may be made where topography justifies but shall not be made merely because the tract has restrictive boundary dimensions, in which a provision should be made for extension of street pattern to the adjoining un-platted parcel and a temporary turnaround installed.

Cul-de-sac lengths in excess of the City Code maximum may be considered only if the following conditions are present:

- The subdivision is be zoned RE-43, RE-35, RE-24, R1-18, and R1-14.
- The minimum lot width 110’.
- In no instance shall the cul-de-sac length exceed 600’.

## 7.4 EASEMENT PLANNING

Easement shall follow City Code 32-30. Plats that seek to combine previously subdivided parcels for consolidation may not be required to dedicate an 8’ Public Utility Easement (PUE) adjacent to the right-of-way.

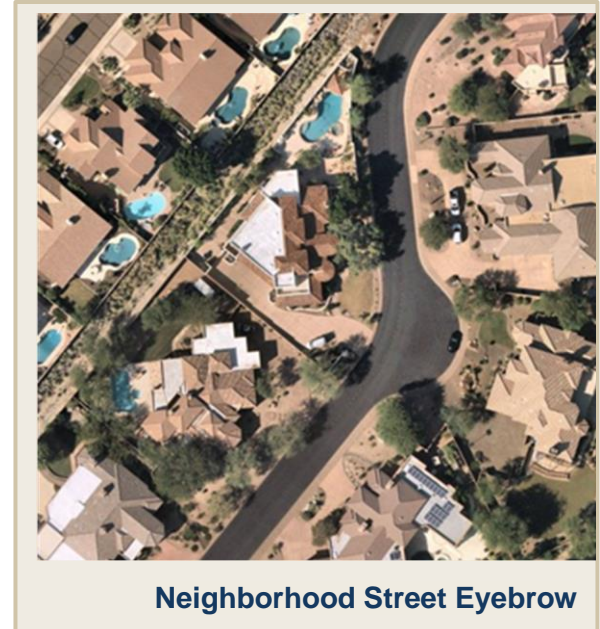

Figure 7.2-3 Eyebrow

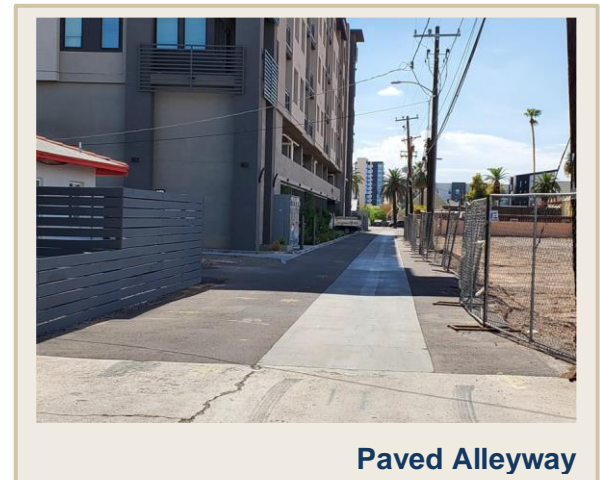

Figure 7.2-4 Paved Alleyway

### 7.4.1 Street Abandonment

Abandonments are to be in conformance to City Code, Chapter 31 Article V.

- An existing street may be considered for abandonment if it is not a street indicated on the City of Phoenix Street Classification Map or an Area Plan and will not eliminate reasonable and legal access to existing properties or negatively affect the connectivity of a neighborhood or street network. The abandonment should alleviate a significant traffic problem and not create new problems. If a street is approved to be abandoned, the abandonment must occur prior to the submittal of a final plat to the City Council. If a plat is required, the abandonment must occur concurrent with approval of the plat by City Council.
- Alleys and excess right-of-way as identified by the City's Street Classification System on any type of street may be considered for abandonment if approved by the City.

### 7.4.2 Street and Utility Improvement Requirements

Engaging with utilities early in a project is critical to prevent delay. Coordinating utility improvements on project that involve SRP Irrigation relocations (typically associated with a land transaction and the need for an SRP Irrigation design) can often take 18 months or more. A meeting with the City of Phoenix is not required prior to beginning discussions with SRP on Land and or Irrigation requirements.

Street and Utility Improvements Requirements shall be in conformance to City Code 32-33. The following provides additional detail, context and clarity in the design and intent of City Code 32-33.

#### SRP Irrigation Relocations:

- Existing SRP closed or open irrigation channels/facilities shall be tiled (i.e.) undergrounded, piped, and relocated outside of existing or proposed rights-of-way dedications or as approved by the Utility Coordination Section of the Street Transportation Department for areas where special conditions exist.
- When Irrigation facilities are within USA Fee land, the Developer shall apply for formal land transfer with SRP and the Bureau of Reclamation. Land transfers shall be relocated outside the entirety of existing or proposed rights-of-way and associated public utility easement and be completed prior to subdivision plat approval. Developments seeking exception will require the approval of the Utility Coordination Section of the Street Transportation Department for areas where special conditions exist.
- When Irrigation facilities are within USA Easement, the Developer shall apply for relocation of the easement with SRP and the Bureau of Reclamation. The USA Easement shall be relocated outside the entirety of existing or proposed rights-of-way and associated public utility easement and be completed prior to subdivision plat approval. Developments seeking exception will require the approval of the Utility Coordination Section of the Street Transportation Department for areas where special conditions exist.
- USA Easements may be platted over the right-of-way for the transition area between the relocated and existing facility tie-in point.
- USA Fee Title Transfers and USA Easements shall be coordinated through SRP in conformance with their most current processes.

- Per City Code 32-30 SRP easements shall not overlap within a public utility easement and shall begin at the back of the required 8' public-utility easement.
- Required right-of-way and site tree planting shall be designed to be outside of existing or proposed SRP designated areas.

### Large Diameter Power Poles

- Developer will perform due diligence by engaging pole owners during project scope to obtain information pertaining to relocation and/or required roadway clearances, as well as any existing easements or land rights that need to be maintained or revised due to the development process.

### Small Diameter Power Poles

- Small diameter power poles (12 kV or less) shall be in conformance with Phoenix Municipal Code 507 Tab A.II.B.7 (7.5), which requires that all new or relocated electric lines 12 kV and smaller, communications and cable television and all on premise wiring should be placed underground in all developments where visible from streets or adjoining properties. Phoenix Municipal Code 32-25 A.2 requires all electrical lines 12.5 kv and smaller shall be installed underground.

### Overhead Conversion Power Poles

- Development plans that require the conversion of electrical conductors from overhead to underground shall have the underground installation shown in the engineered plans submitted to the Street Transportation Utility Coordination section. Any deviation from this requirement will be denied unless accompanied with by approved Technical Appeal from the Planning and Development Department.

### Existing Overhead Power Pole Clearances

- Development plans that do not have an overhead to underground conversion requirement will perform due diligence by engaging pole owners during project scope to obtain requirements pertaining to overhead line clearances from vertical structures, or “clear zones” as represented by APS or SRP.
- Development plans that do not have an overhead to underground conversion requirement will perform due diligence by engaging pole owners during project scope to obtain requirements pertaining to any existing aerial easements that need to be maintained or revised due to the development process.

### Street Transportation Requirements for Developer Utility Installations

Conduit installation by Developer for dry utilities requires a Trenching Permit from the Planning and Development Department that is only issued when accompanied by an approved APS or SRP Utility Permit issued by the Street Transportation Department. The bullet points below provide guidance on what information should be shown on Development plans provided to utility companies for submittal to obtain a Street Transportation Utility Permit.

- Development plans submitted to Street Transportation for utility permitting will be reviewed for adherence to Administrative Procedure (AP) 5.1 Requirements for Obtaining a Permit and Utility

Construction Guidelines in Public Rights-of-Way.<sup>10</sup>

- Development off-site plans for underground utility installation will identify whether utilities will be installed jointly, and if so, will include which utility companies will be occupying the joint utility trench.
- Development off-site plans for underground utility installation will identify whether underground installation will be performed via trench or bore.
- Developer will supply to utility companies their final version of off-site plans for utility design. Supplying preliminary designs where revisions may be needed will delay the Street Transportation permitting process, therefore delaying utility installation.
- Development supplied off-site plans will include a well-defined area for utility companies to include linear footages for work in rights-of-way, private streets, and public utility easements. Accurately providing this information is crucial to the creation and issuance of the Developer's Trenching Permit for conduit installation.

### Existing Private Facilities within existing and/or proposed Right-of-Way

- When any existing underground or above-ground private facilities on private property must remain operational or in place, either as installed or within proximity to its current location to provide continuous operation of the service that it provides, the owner of the private facility and the property owner must contact the City's Street Transportation Department to determine if the private facility will be allowed to remain in the existing and/or proposed dedicated right-of-way.
- When existing underground private facilities are located on private property that will be or is acquired by a developer and the ongoing operation of the private facilities require it to remain underground in existing and/or proposed dedicated right-of-way, the owner of the facilities may apply for a Revocable Permit to allow for the facilities to remain in place. The City may allow the private facility to remain in place, require it to be relocated in another section of right-of-way, or require it to be relocated to private property. If the City allows the private facility to remain in the right-of-way under a Revocable Permit, the owner of the private facility must: 1) register their facility with AZ811 (Blue Stake) Center, 2) pay the fee for the Revocable Permit, and 3) maintain insurance in accordance with the terms of the Revocable Permit.
- When existing above-ground private facilities are located on private property that will be or is acquired by a developer and the Streets Transportation and the Planning and Development Departments have approved the ongoing presence and location of the above-ground private facilities in existing and/or proposed dedicated City right-of-way, the owner of the facilities may apply for a Revocable Permit to allow for the facilities to remain in place. The City may allow the private facility to remain in place, require it to be relocated in another section of right-of-way, or require it to be relocated to private property. If the City allows the private facility to remain in the right-of-way under a Revocable Permit, the owner of the private facility must: 1) register their facility with AZ811 (Blue Stake) Center, 2) pay the fee for the Revocable Permit, and 3) maintain insurance in accordance with the terms of the Revocable Permit.

<sup>10</sup> <https://www.phoenix.gov/streetssite/Documents/AP%205%201%20-%20September%202017.pdf>



# 8. BIKEWAYS AND ACTIVE TRANSPORTATION

# 8

## OVERVIEW

The City of Phoenix is committed to providing a safe, connected, and comfortable active transportation system. The primary purpose of the active transportation network is to provide enjoyable transportation options for all residents.

The focus of this chapter is to provide design guidance for facilities that are used by people riding bicycles.



## Chapter 8 --- BIKEWAYS AND ACTIVE TRANSPORTATION

### 8.1 INTRODUCTION

The City of Phoenix is committed to providing a safe, connected, and comfortable active transportation system. The primary purpose of the active transportation network is to provide enjoyable transportation options for all residents. Active transportation supports sustainability and provides access to those who utilize active modes regularly or periodically. Active transportation includes walking, bicycling, using mobility aids, or other small electric vehicles, such as e-scooters.

While the focus of this chapter is to provide design guidance for facilities that are used by people riding bicycles; the City of Phoenix recognizes that scooters, non-motorized skateboards, and others may utilize the same infrastructure. For simplicity and clarity, the term “bicycles,” “bicycling,” or “persons riding a bicycle” are used, but not to the exclusion of people using mobility aids, riding scooters, and using non-motorized skateboards, etc.



**Example of Active Transportation Improvement**

#### 8.1.1 Planning for Active Transportation

Active transportation can be used for commuting, utilitarian, social, recreational, or fitness/health purposes. Providing enjoyable active transportation infrastructure for all residents can:

- Replace the use of cars for many short trips.
- Help reduce traffic congestion, air pollution, and demand for parking.
- Benefit those who cannot drive or cannot afford a car.
- Provide healthy recreation for families and people of all ages.
- Help maintain Phoenix as a livable city with an outdoor lifestyle.

Planning for active transportation should be approached in a comparable way to conventional transportation planning considering factors such as access, convenience, safety, cost, efficiency, latent demand, induced demand, travel demand, connections, and engineering.

However, unlike design guidelines for motor vehicle infrastructure, previous bicycle infrastructure design has focused on the users with the highest levels of risk tolerance. In order for bicycle infrastructure design to be widely used, all potential users must be considered in the design. As the age range of bicyclists includes children, the physical and cognitive abilities of children must be considered during design. Network connectivity is important for ensuring people using bicycles can access the

places they want to go. The bicycle network should facilitate short trips and make it easy for people to substitute car trips for bicycle trips or bicycle plus transit trips to take care of their everyday travel needs. Even a small network gap, such as a dropped bike lane at an intersection can deter someone from riding a given route. A connected network is one with no gaps, a density of routes appropriate for the intensity of land uses, and direct, seamless transitions between facilities.

The City of Phoenix encourages enhanced bikeway design in accordance with City of Phoenix Climate Action Plan, Complete Streets Policy, and Vision Zero resolution. Developers are encouraged to meet with City of Phoenix Street Department, Active Transportation Team, to discuss design need and requirements. Any design that would impact the roadway capacity will need approval of the Street Transportation Department.

## 8.2 BIKEWAY SYSTEM COMPONENTS

The types of bikeways used in the City of Phoenix are on-street bicycle lanes, including protected and buffered bike lanes, shared-use paths or multi-use trails, and bicycle boulevards.

Not all streets have a designated bicycle travel facility, but they are open to bicycles. This includes all public streets unless specifically posted to prohibit cyclists. While the suitability of streets will vary, the basic street grid will always provide the major foundation for bicycle travel.

Opportunities to provide bicycle access may occur in conjunction with public or private development, greenbelts, canal banks, flood control projects, vista corridors, or any place with available open space or right-of-way. It is the intention of Phoenix's bicycle planning efforts to remain flexible and open to new opportunities.

**On-Street Bicycle Boulevard:** Bicycle boulevards are local streets designed to prioritize bicycle travel. These streets have low traffic volumes, and the motor vehicles present are mostly making local trips and traveling at speeds 25 mph or lower. Traffic calming and diversion measures are necessary to achieve these conditions. Other essential elements of bicycle boulevards include wayfinding signage/pavement markings and safe arterial crossings that include traffic control measures and minimize travel delay for bicyclists.

**On-Street Bicycle Lanes:** On-street bike lanes are an integral section of a roadway which is marked for exclusive bicycle use. On-street bike lanes are one-way facilities. Buffered bicycle lanes, with a buffer between the bicycle lane and the adjacent travel lane, enhance the bicyclists experience and comfort.

**Protected Bike Lanes:** Protected bike lanes (also known as cycle tracks or separated bike lanes) are bike lanes separated from adjacent traffic by a lateral buffer with vertical elements. These bikeways offer a higher degree of safety and comfort to people bicycling. When one-way protected bike lanes on both sides of the street are not feasible, two-way protected bike lanes can allow bicycle movement in both directions on one side of the street. These two-way protected bike lanes share the same design characteristics as one-way protected bike lanes but require additional considerations at driveways and intersections.

**Shared-Use Paths:** Shared-use paths are paved pathways that are clearly separate from the road infrastructure. Shared-use paths are shared with bicycles, scooters, skaters, and pedestrians. In general, shared-use paths are intended for two-way traffic.

**Multi-Use Trails:** The trails surface generally consists of stabilized, decomposed granite. These trails are open to equestrian, bicycle, and pedestrian travel.

**Intersection treatments:** Treatments including signalization and phasing can improve the safety and comfort of bicyclists. These include continuing the bike facility up to and through the intersection, providing queuing space out of the flow of vehicle traffic, bicycle signals, etc.

**Grade-Separated Crossings:** Underpasses or overpasses separate motorized and non-motorized traffic from each other at points where these roadway users intersect.

### 8.3 ON-STREET BICYCLE BOULEVARD

Many local and neighborhood streets with low-existing speeds and volumes provide the basic components of a safe and comfortable environment for people riding bicycles. These streets can be enhanced with design treatments, tailored to existing conditions and desired outcomes, to create neighborhood on-street bicycle boulevard:

1. Signs and Pavement Markings to make the boulevard easy to find and to follow.
2. Speed Management to slow motor vehicle speeds to 25 mph or less.
3. Volume Management to reduce motor vehicle volumes to less than 3,000 vehicle per day, 1,500 vpd preferable.
4. Minor Street Crossings to minimize bicyclist delay.
5. Major Street Crossings to provide safe and convenient crossings.
6. Green Infrastructure to enhance comfort.

Refer to the City of Phoenix Active Transportation Team for design example, at [Bike@Phoenix.gov](http://Bike@Phoenix.gov).

### 8.4 ON-STREET BICYCLE LANES

Striped/painted bike lanes are a portion of the roadway designated for preferential use by bicyclists by use of pavement markings and, optionally, signage. Parking should not be permitted in bike lanes at any time.

All collector streets should have striped/painted bike lanes unless otherwise directed by the Street Transportation Department. All new construction shall include striped/painted bike lanes on parkway, arterial, and collector streets.

Buffered bike lanes, separated bike lanes, or protected bike lanes may be required on streets with high traffic volumes or favorable curb to curb geometry.

#### 8.4.1 Bike Lanes on Bridges/Tunnels/Grade Separation

Bridges, tunnels, or any grade separation structure, should allow the full width of the physical improvements including standard bike lanes. Bridges and tunnels with solid barriers alongside often become dangerous constriction points for bicycle travel. Consideration should be given to maintaining extra width on bridges and in tunnels even if the street does not have bike lanes.

#### 8.4.2 Bike Lanes on Rural Streets

In rural areas, a paved shoulder can serve the function of a bike lane, in which case it should have a minimum of 5' of paving.

### 8.4.3 Bike Lanes on Streets with On-Street Parking/Parking Protected Bike Lanes

A bicycle lane can be delineated with striping between an area for parallel parking and a traffic lane or between parking and the curb. This second arrangement constitutes a parking protected bike lane. A parking protected bike lane should provide a 4' buffer between the bike lane and the parked car to allow the buffer to be used as a walkway to access the curb ramp at the nearest intersection.

### 8.4.4 Bike Lane Width

Bike lane width should meet dimensions summarized in **Table 8.4-1**. Changes in bike lane width and horizontal and vertical alignment should be smooth. A solid 8" white stripe is used to mark the bike lane. The use of minimum bike lane widths is preferable to the provision of wide outside vehicle-travel lanes. Minimum-width bike lanes should be limited to constrained situations where the preferred widths cannot be provided after all other travel lanes have been narrowed to minimum widths.

Table 8.4-1 Preferred and Minimum Widths of Bike Lanes

<i>Bike Lane Description</i>	<i>Preferred Width (ft)</i>	<i>Minimum Width (ft)</i>
<i>Bike lane with buffer</i>	6' (bike lane) 3' (Buffer)	5.5' (bike lane) 2.5' (Buffer)
<i>Bike lane adjacent to curb (from face of curb)*</i>	6' – 7.5'	5.5'
<i>Bike lane adjacent to edge of pavement</i>	5' – 7.5'	4.5'
<i>Bike lane between travel lanes and turn lanes</i>	6' – 7.5'	5'
<i>Bike lane adjacent to parking**</i>	6' – 7.5'	5'
<i>Intermediate or sidewalk level bike lane (see Figure 8.7.1)</i>	6' – 10'	5'
<i>Bike lane to allow side-by-side bicycling or passing</i>	8' – 10'	8'

\*Parking protected bike lanes require a 4' buffer (3' minimum) between the bike lane and parking lane.

\*\*Assumes a 1.5' gutter. Minimum bike lane width 4' (even surface) exclusive of gutter unless the gutter is integrated into the full width of the bike lane.

Adding buffer space or wider bike lanes may be preferable in the following situations:

- Where parking is present and turnover is high.
- Where it is desirable to allow bicyclists to travel side-by-side or to pass each other.
- On roadways with posted speeds over 25 mph or 3,000 vehicles/day.
- Where the percentage of heavy vehicles exceeds 5 percent.
- Where bicycle lanes are located between two moving travel lanes, such as between a through lane and a turning lane.
- Where there are multiple lanes of vehicle traffic per direction.

Bike lanes wider than 7.5' (assuming a 1.5' gutter) should include a buffer or buffer with vertical elements to minimize their appearance as a travel lane or parking lane for motorists.

### 8.4.5 Bicycle Stencils

Painted/striped bike lanes are demarcated with a white-lane line and green-backed bicycle stencils. Bicycle stencils are added to alert all users of the roadway that a designated area is identified as the bike lane.

Bicycle stencils (**Figure 8.4-1**) should be placed 30'-50' downstream from an intersection. The first marking after an intersection or driveway should be placed outside of the wheel path of turning vehicles, to reduce wear. If a far side bus stop is present, the bicycle lane marking should be placed after the bus stop, outside of the area frequently used for the bus to merge into the adjacent lane.

Bicycle stencils are generally spaced every quarter mile. In Downtown and urban areas, where conflicts with motorists may be higher (i.e., where there is significant parking turnover, at intersections, at driveways, at turn lanes), it is appropriate to space the symbols closer than the quarter mile spacing. In areas with long distances between intersections and little roadside activity, bicycle stencils may be spaced even further apart, as approved by the Street Transportation Department.

Bicycle stencils are added in conflict zones or to denote where a bike needs to move to another area. For example, where a bike lane continues on the left side of a right-turn-only lane, bicycle stencils should be placed in the bike lane adjacent to the turn arrows for the right-turn-only lane. Bike lanes should be continuous between intersections and not stop or leave a gap as approaching the intersections or driveways.

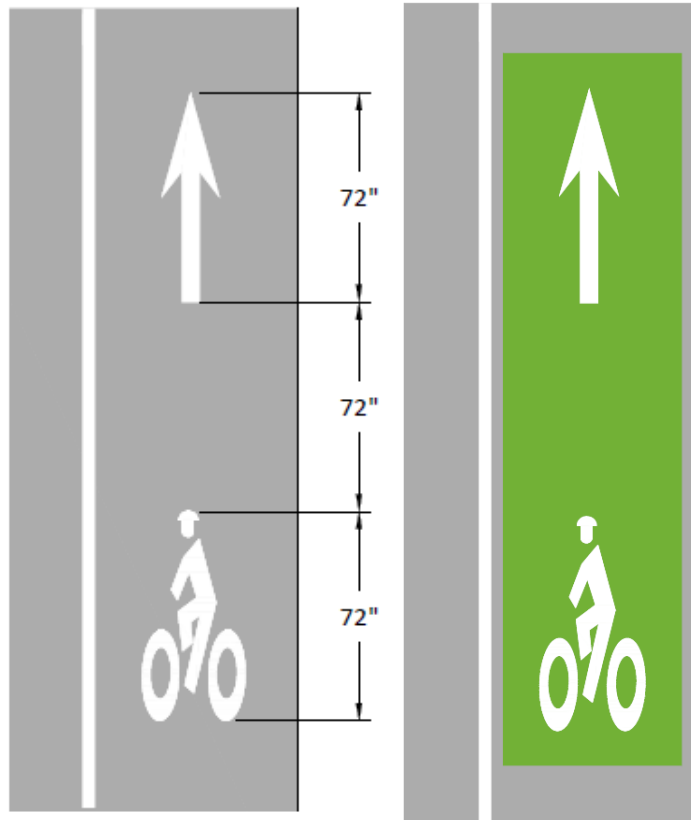

Figure 8.4-1 Standard and Green Backed Bike Symbol

## 8.5 ON-STREET BUFFERED BIKE LANES

Increasing the lateral separation between motor vehicles and people riding bicycles provides a more comfortable condition for both those riding bicycles and vehicles. Buffered bike lanes are the preferred bike lane wherever space allows.

Bike lanes can be improved through the provision of a painted buffer (Figure 8.5-1, Figure 8.5-2, and Figure 8.5-3) between the bike lane and adjacent travel lane and/or between the bike lane and parking lane. The painted buffer provides a spatial and visual separation between parked or moving motor vehicles and the bicycle lane. The bike can be reduced to the 4' minimum (excluding gutter) to achieve a buffered bike lane.



Figure 8.5-2 On-Street Buffered Bike Lane

Buffered bike lanes (Figure 8.5-3) generally consist of a combination of standard longitudinal markings and cross hatching as illustrated in Figure 8.5-4. Buffers less than 2.5' in width are to be used only in short, constrained sections, and do not have cross hatching.

Where provided, cross hatching should be provided at a regular interval. A typical spacing (L) is 40' for speeds less than 40 mph and 80' for speeds 40 mph or greater. Spacing may be reduced to as frequent as 5' where engineering judgment determines a more frequent spacing is desirable.

The use of an additional buffer between the bike lane and parking lane is desirable when parking turnover is frequent (e.g., short-term parking), where loading/unloading activity is high, or when larger vehicles are typically using the parking lane.

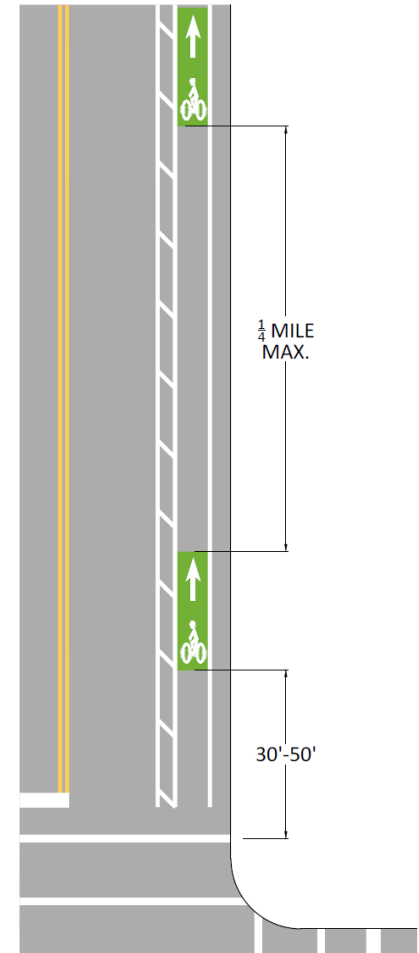

Figure 8.5-1 Typical Bike Lane Layout

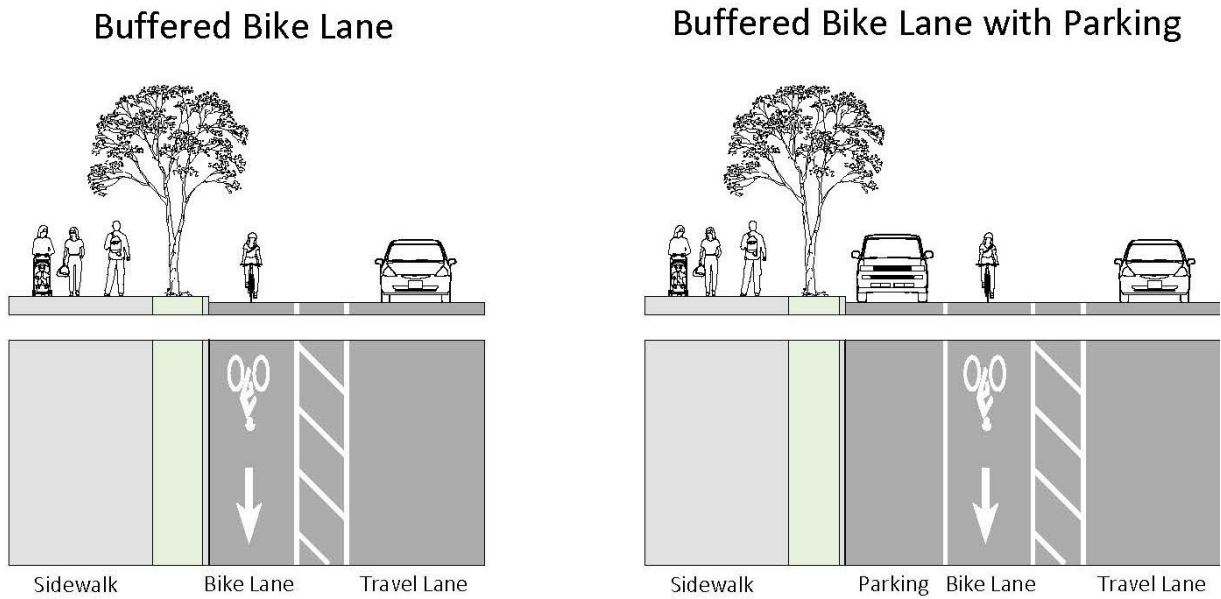
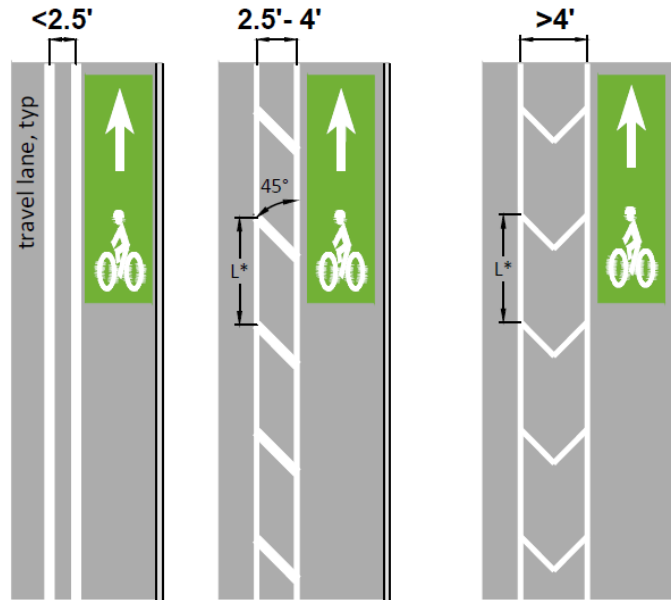

Figure 8.5-3 Typical Buffered Bike Cross-Sections



L = 20' (typical); L = posted speed limit (max)  
 \*spacing may be reduced where engineering judgement determines more frequent spacing

Figure 8.5-4 Typical Buffered Bike Lane Pavement Markings



## 8.6 PROTECTED BIKE LANES

Protected bike lanes are a type of bicycle facility that provides an exclusive space for bicyclists along or within a roadway. Protected bike lanes (**Figure 8.6-1**) have two fundamental elements: horizontal offset from adjacent motor vehicle lanes and vertical objects located within that offset. An offset between bike lanes and pedestrian space is also desired if the bike lane is at sidewalk level. Developers are instructed to contact City of Phoenix Streets Department if a protected bike lane is adjacent, planned, or desired.

Protected bike lanes may be designed as either one-way or two-way (**Figure 8.6-2**), and may be constructed at street level, sidewalk level, or at an intermediate level between the street and sidewalk. Separation can be achieved with inclusion of objects such as vertical curb, planters, flexible delineator posts, or parked vehicles, among others, placed in the street buffer.



Figure 8.6-1 Two-Way Protected Bike Lanes

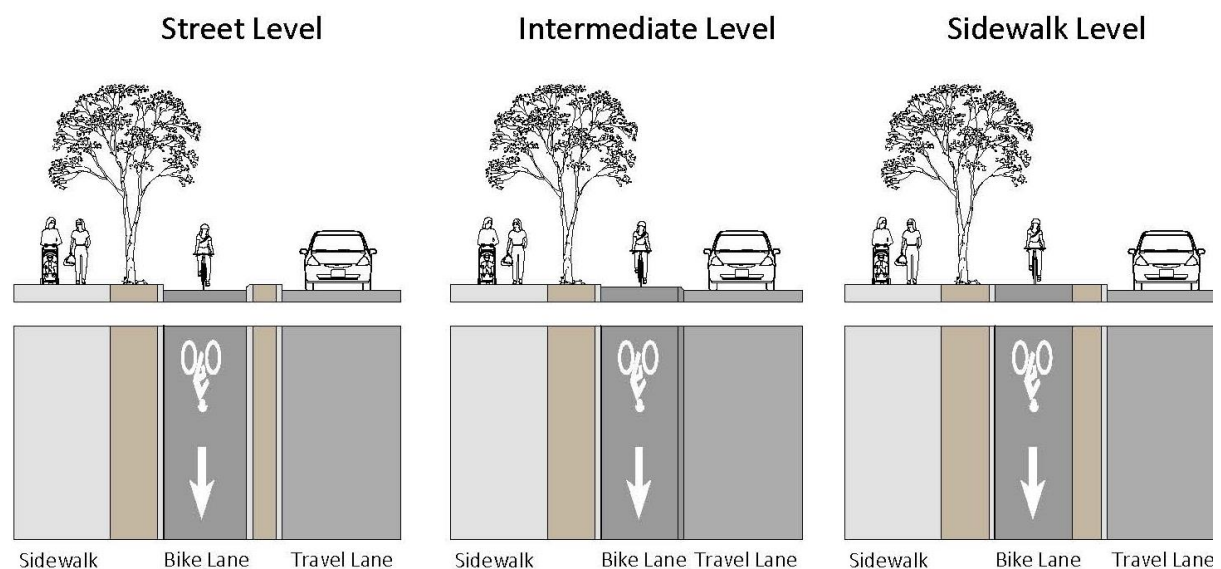

Figure 8.6-2 Separated Bike Lane Types

## 8.7 CURB INLETS/STORM DRAIN GRATES

Drainage grates with openings running parallel to the direction of bicycle travel can cause narrow bicycle wheels to drop into the gaps and cause a crash. It is preferable to avoid drainage grate concerns by installing inlets, which only have curb face openings. Drainage grates should be located outside the bicycle facility whenever possible, however when unavoidable, care should be taken to ensure that drainage grates are bicycle-compatible, with openings small enough to prevent a bicycle wheel from falling into the slots of the grate (See **Figure 8.7-1**).

Drainage grates and utility covers that extend into the bicyclist operating space may cause bicyclists to swerve, effectively reducing the usable width of the bike lane. Where grates are located within a bicycle facility or adjacent to bicyclists' operating space, the gap between the drainage grate and its frame should be 0.5" or less, and it should be perpendicular to the path of travel. Another option is to place the grate entirely within a gutter or curb rather than extending it into the bicycle facility.

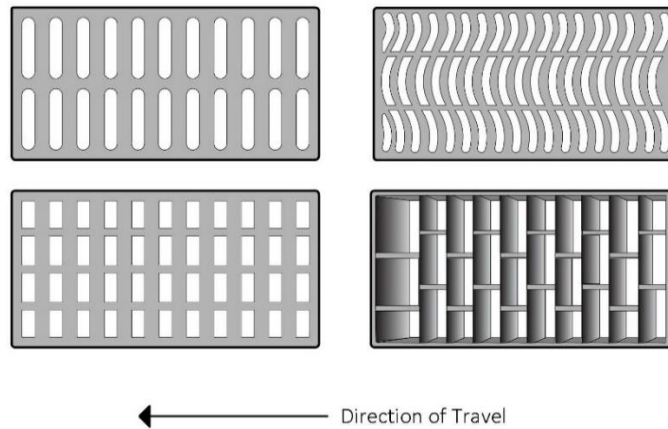

Figure 8.7-1 Bicycle Compatible Drainage Grates

## 8.8 CONNECTIONS TO PRIVATE PROPERTY

Developers are encouraged to provide comfortable and safe access from a protected bicycle lane to the adjacent property. Access may be provided at block ends, using a standard or widened curb ramps, mid-block using a driveway or a modified driveway (6'-8' wide) for bicycle access, or with a bike ramp with a trapezoidal delineator (**Figure 8.8-1**). Contact the City of Phoenix Street Transportation Department for information about a modified driveway for bicycle access.

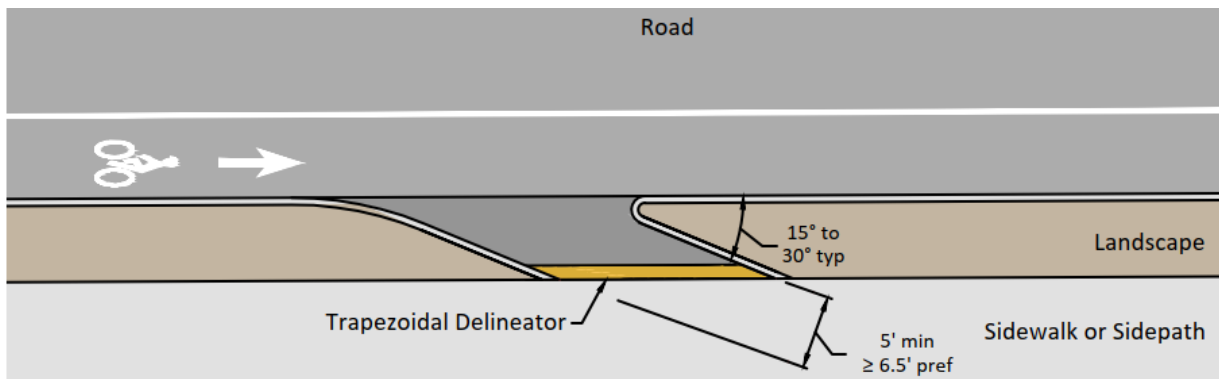

Figure 8.8-1 Example of Bike Ramp

## 8.9 SHARED-USE PATHS

### 8.9.1 Design Considerations

Shared use paths (**Figure 8.9-1**) are facilities on exclusive right-of-way. Shared use paths are sometimes referred to as trails; however, to some, the term trail means an un-improved recreational facility.

City of Phoenix requirements for shared-use paths (**Table 8.9-1**) are found in City of Phoenix Supplement to MAG Uniform Standard Specifications, section 429 and details P1130 and P1131. For additional information, please refer to the AASHTO Guide for the Development of Bicycle Facilities.

Every attempt should be made to avoid having a path adjacent to a street. If this is unavoidable, on arterial streets a separation of at least 8' with landscaping should be provided and on collector streets a separation of at least 5' should be provided.

Connections between different types of facilities is important to ensure an efficient and functional system. Shared-use paths may be used to connect sections of roadways that would otherwise dead-end. However, it is critical not to attempt to substitute a path or a sidewalk where bike lanes are warranted. Bike lanes allow direct, higher-speed travel for cyclists, unimpeded by pedestrians.

Shared-use paths are typically two-way; designing a path to connect with one-way bike lanes requires study and design to that the bicyclist does not end up riding the wrong way (against traffic) in one of the bike lanes.

As shared-use paths connect or cross arterial or collector streets, the crossing of the street needs to be considered in the overall design to maintain connectivity. A safe and convenient crossing needs to be implemented with the overall design of the shared-use path. A traffic signal, pedestrian hybrid beacon, or raised median island may be required depending on the volume, speed, width, and additional factors of the roadway. The developer is instructed to contact Street Transportation Department for type of crossing required.



**Example of Shared-Use Path**

*Figure 8.9-1 Shared-Use Path*

Table 8.9-1 Shared-Use Path Design Considerations

<b>Design Speed</b>	20 mph
<b>Typical Width</b>	10' wide (minimum) with 2'-foot graded shoulder on each side, 5' horizontal clearance, and 10' vertical clearance.
	8' or more where paths can be paired so each can have one-way travel.
	14' in areas with high use and/or a wide variety of users. Where pedestrian and bicycle activity are high, it may be advantageous to have separate paths for walking and bicycling rather than increase the path width to minimize speed differential between pedestrians and wheeled users.
<b>Surface</b>	Variables by use. Surfaces may include decomposed granite, turf, or concrete with medium broom finish. On concrete surface, it is desirable to provide traction, but not to a degree that impedes skaters.
<b>Shoulders</b>	Material for the shoulders should allow for recovery if a user runs off the path. Substances such as turf, decomposed granite, exposed aggregate, or low shrubs/grasses are appropriate. No spiny/thorny plants.
<b>Clear Zone</b>	An area clear of fixed objects such as poles or tree trunks for another 3' beyond the shoulder is desirable.
<b>Fencing/Rail</b>	Where needed, fences or railings for paths or bikeways should be 54" in height (40" minimum) and be flared at the ends.
<b>Vertical Clearance</b>	8' over the path and shoulder areas; 10' for underpasses
<b>Horizontal Grade</b>	5 percent or less. Where this is not feasible, refer to the AASHTO Guidelines.
<b>Cross-Slope</b>	Maximum side slope is 2 percent. Maximum cross-slope is 2 percent. Adjacent grades should always direct water away from the path surface.
<b>Alignment</b>	Alignment is as linear as possible. Avoid compound curves. Unnecessary "meandering" reduces the effective width of the path, can create sight distance problems, and increases possibility of users running off the path.
<b>Tunnels</b>	Tunnels should be lighted
	Provision in tunnels to keep nuisance water off the path and allow the water to rapidly drain or be removed. One solution is a small channel constructed with a sloping side, built on one side of the tunnel. Sump pumps are needed in areas prone to flooding.
<b>Ramp</b>	Path ramp design where the pan for any curb ramp shall be as wide as the path. The ramp should be aligned with the path, and not require users to make sudden swerves, or to be directed towards oncoming traffic.

### 8.9.2 Easements, Dedications, and Abandonments

Sometimes on-street facilities may need to be connected with short sections of paved path. As an example, connecting cul-de-sacs that have only one direct access to the public street system. The cul-de-sac street can be connected to allow bicycle and foot access to reach adjacent streets, paths, trails, or property.

If a private-gated community will cut off functional access for cyclists, means should be explored to maintain a public-use easement on the streets and through the gates for pedestrians and cyclists.

For off-street paths/trails, right-of-way may need to be obtained from development stipulations, or purchased. Any easements or dedications for paths should include a clear statement of maintenance responsibilities for the actual concrete path, any adjacent landscaping or lighting, and for maintaining proper grades and drainage along the path. Dedicated right-of-way or public use easements for paths must be noted in the stipulations and on the site plan. This should occur in the Project Review process for new developments. If the classification of an existing or planned street is proposed to be changed, or a street easement or right-of-way proposed for abandonment, present and potential pedestrian and bicyclist connections should be reviewed. The proposed change shall be evaluated against the needs of the active transportation program. Public use easement for bicycle and/or foot access should be obtained or retained.

## 8.10 TRANSIT STOPS

Transit stops in locations with bike lanes are generally configured in two ways: by continuing the bicycle facility through the stop area (requiring a bike/bus shared space, or bike/bus merge zone), or by routing the bicycle facility around or behind the transit platform (floating stop).

A bike/bus shared space is used in locations where there is insufficient space to route bicyclists behind the transit stop area. Depending on the available width, the bus may cross over or occupy the bike lane.

In locations where an in-lane transit stop is proposed, a floating stop should be considered, by routing the bicycle facility behind the transit platform. **Figure 8.10-1** through **Figure 8.10-3** shows configurations that are applicable for near, far, and mid-block stops. In all cases, a 5' by 8' clear boarding and alighting area that connects to a pedestrian access route must be provided. On multi-lane streets, floating transit stops should be placed on the far side of the intersection only. The pedestrian crossing of the bicycle facility should be marked with crosswalk markings and pavement marking/signage should indicate that bicyclists should stop for pedestrians accessing the transit platform. Additional guidance related to accessibility, clearances, and mitigating conflicts is provided in the AASHTO Guide for Development of Bicycle Facilities.

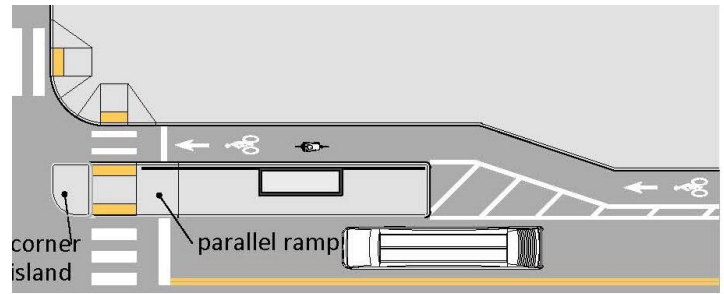

ALTERNATIVE 1

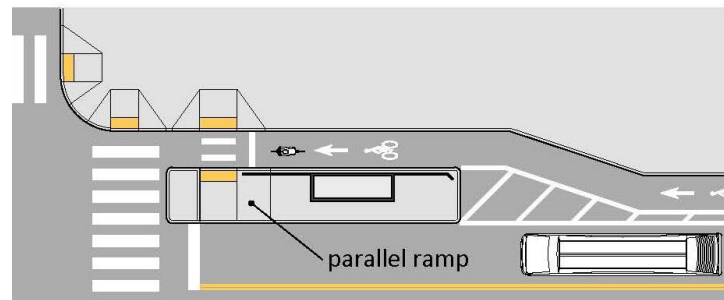

ALTERNATIVE 2

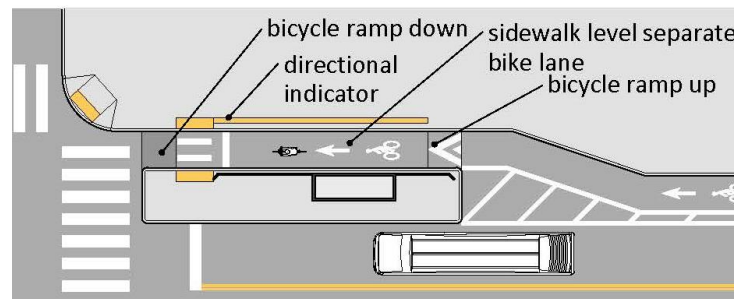

ALTERNATIVE 3

Figure 8.10-1 Bike Lane Routing Behind Transit Stop (Near-Side)

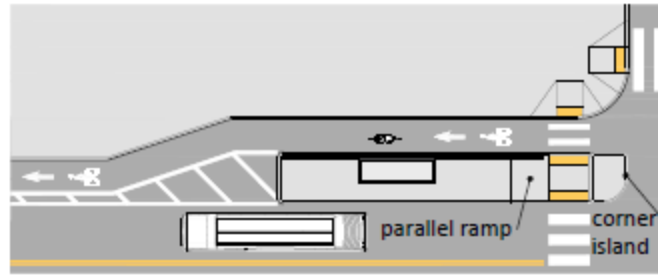

ALTERNATIVE 1

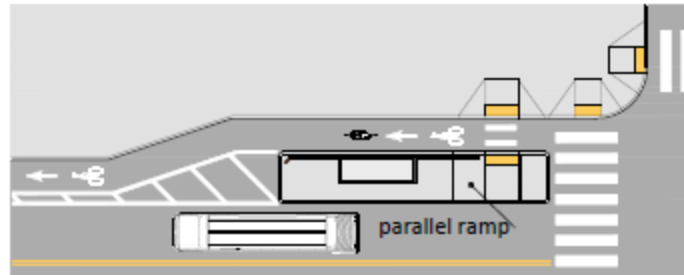

ALTERNATIVE 2

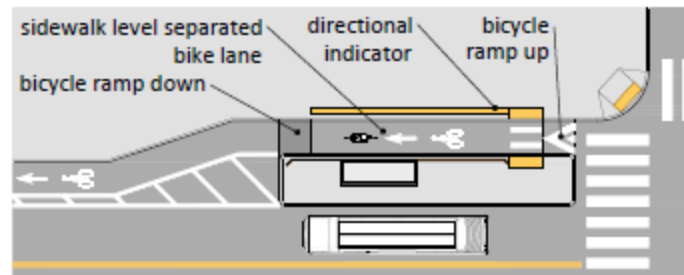
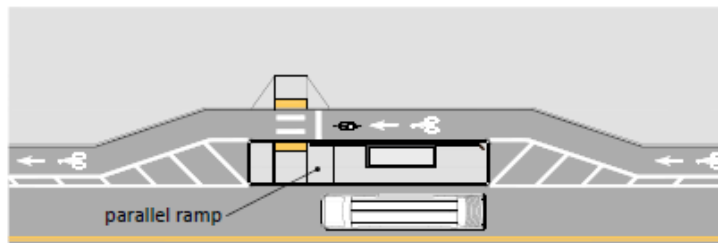

Figure 8.10-2 Bike Lane Routing Behind Transit Stop (Far-Side)



ALTERNATIVE 1

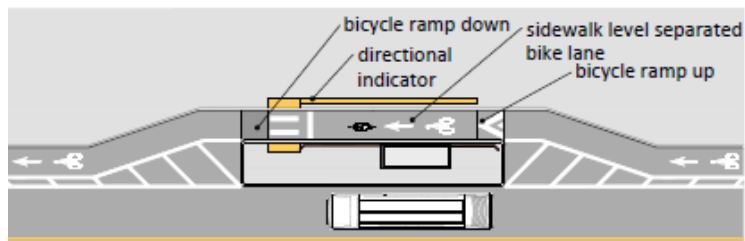

Figure 8.10-3 Bike Lane Routing Behind Transit Stop (Mid-Block)

## 8.11 RAIL CROSSINGS

The angle at which at-grade rail lines intersect with a bicycle facility is a critical design consideration. The preferable skew angle between the center line of the tracks and the bicycle facility is between 60 and 90 degrees (**Figure 8.11-1**) so bicyclists can avoid catching their wheels in the flange and losing their balance.

When rails curve through an intersection, the safe path for a cyclist may not be intuitive. In this case, pavement markings may be used to indicate the bicyclists' path of travel across the rails. Care should be taken that the path of travel does not conflict with movements from other roadway users.

When rails are located parallel to a bicycle facility, consideration should be given to connections to adjacent bicycle facilities at intersections. Two-stage turn queue boxes are provided to facilitate a 90-degree crossing of the rails, to indicate an alternative to crossing the parallel tracks.



Figure 8.11-1 Bike Lanes at Rail Crossings

## 8.12 TRANSITION POINTS AND ENDING BICYCLE FACILITIES

Each bicycle facility begins and ends at a specific location and will either terminate or transition into another distinct bikeway. The following section describes design considerations to safely transition and terminate the facilities described above.

Transitions of two-way separated bike lanes to bikeways or shared lanes that require one-way bicycle operation require particular attention. Bicyclists operating counterflow to traffic will be required to cross two roadways. Failure to provide a clear transition to the desired one-way operation may result in wrong-way bicycle riding. It may also be desirable to use green-colored pavement within crossings and



two-stage bicycle turn boxes to improve legibility and provide strong visual guidance of the intended path across the intersection to all users. The crossing may warrant bicycle signals at signalized crossings. The signal should be coordinated with the intersecting street signal phase. Site-specific conditions and engineering judgement should determine the most appropriate treatments for ensuring a safe and intuitive bikeway transition.

### 8.13 CONFLICT ZONE MARKINGS

At locations where designated bicycle facilities cross intersections and driveways, conflict markings (**Figure 8.13-1**) may be provided to guide bicyclists along their path of travel while clearly designating locations where bicycles and motor vehicles will intersect. Bicycle intersection treatments requires coordination with traffic services and the City of Phoenix Active Transportation Team.

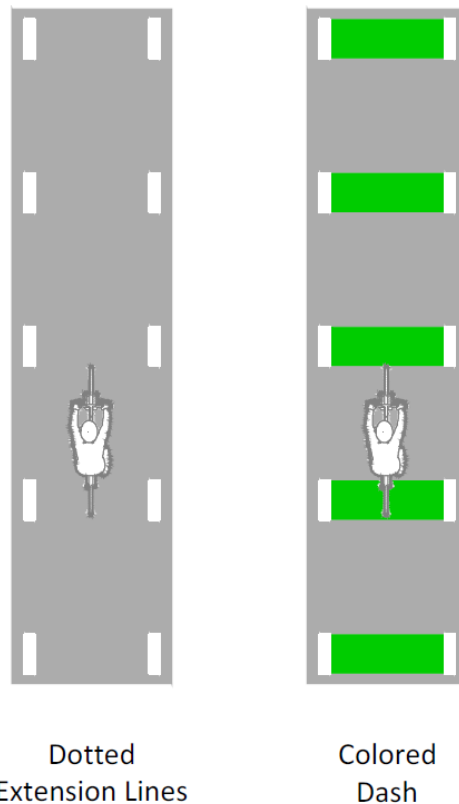

*Figure 8.13-1 Typical Bicycle Conflict Markings*

# 9. TRAFFIC IMPACT ANALYSIS

## OVERVIEW

This chapter is prepared to assist an applicant to satisfy the requirement of performing a Traffic Impact Analysis (TIA) when requesting access to a city street.



# Chapter 9 --- TRAFFIC IMPACT ANALYSIS

## 9.1 INTRODUCTION

This chapter is prepared to assist an applicant to satisfy the requirement of performing a Traffic Impact Analysis (TIA) when requesting access to a city street.

Development or redevelopment may require improvements to adjacent and nearby streets to ensure that traffic continues to operate safely and efficiently. A TIA evaluates the magnitude of traffic impact resulting from the proposed development or redevelopment project and provides recommendations to effectively mitigate adverse contributions.

The TIA scope is tailored to the scale of the proposed development activity. Development that is expected to have minimal traffic impacts will complete a focused and limited analysis or potentially no analysis.

Development or redevelopment activity that is expected to have greater impacts would complete a broader, multimodal, in-depth analysis. The Applicant and Street Transportation Department will coordinate to define the scope, type, and scale of analysis appropriate to the development or redevelopment activity.

The TIA shall be prepared in accordance with guidelines published by the Institute of Transportation Engineers and submitted studies shall be sealed by a Civil Engineer duly experienced in their preparation and licensed by the State of Arizona.

### 9.1.1 Scoping Process

The requirement and scope for a TIA is identified considering the scale of the project, intensity of land use, and the resulting anticipated vehicular trip generation. Additional considerations that may lead to a TIA or an expanded scope, include:

- Identified traffic safety or crash histories adjacent or nearby to the site.
- Existing neighborhood traffic concerns or complaints.
- Access control considerations.
- Proximity to transit or other amenities with significant pedestrian demand.
- An overview of the TIA Process Flow is provided in **Table 9-1.1**.

The Applicant is strongly encouraged to arrange a pre-application scoping meeting with Street Transportation Department staff. At this meeting, Street Transportation Department staff and the Applicant will review the project, discuss any known critical issues pertaining to site access, and discuss TIA assumptions and methodologies.

### 9.1.2 City of Phoenix Street Classification Map

The City of Phoenix publishes a General Plan that includes a Street Classification Map. Prior to commencing any study within the City of Phoenix, the Applicant should reference the Street Classification Map for minimum roadway alignments and cross-sections.

Table 9.1-1 Criteria for Determining TIA Study Requirements

<p><b>Site Development Review:</b></p>	<p><b>Rezoning (including PUD) and General Plan Amendments</b></p>	<p><b>Master Plan(s) submittal for PCD Master Plan(s) submittal for PUD, where the gross land area is 320 acres in size or greater Master Plan(s) submittal per rezoning stipulation</b></p>
<p>Refer to <b>Table 9.2-1</b> for criteria Does not meet the criteria? – No further action is needed unless otherwise specified by the Street Transportation Department. Meets criteria? – See submittal process below.</p>	<p><b>Required</b> – Refer to <b>Table 9.2-1</b> for analysis criteria See Submittal Process below.</p>	<p><b>Required</b> See Submittal Process below.</p>
<p><b>Submittal Process:</b></p> <ul style="list-style-type: none"> <li>• Contact the Street Transportation Department to set up a scoping meeting</li> <li>• Submit two hard copies of the Traffic Impact Analysis to the Payments and Submittals counter to be routed to Streets, filed under the project KIVA number.</li> <li>• E-mail an electronic copy to the Street Transportation Department.</li> </ul> <p><b>Subsequent submittals:</b></p> <ul style="list-style-type: none"> <li>• Submit two (2) hard copies to the Payments and Submittals counter to be routed to Streets and e-mail an electronic copy to the Street Transportation Department.</li> </ul>	<p><b>Submittal Process:</b></p> <ul style="list-style-type: none"> <li>• Contact the Street Transportation Department to set up a scoping meeting</li> <li>• Submit two (2) hard copies of the Traffic Impact Analysis to the Payments and Submittals counter to be routed to Streets, filed under the project KIVA number. The study shall be submitted prior to or on the same day of the rezoning case submittal.</li> <li>• Submit one (1) hard copy in the rezoning case file.</li> <li>• E-mail an electric copy to the Street Transportation Department and the Village Planner.</li> </ul> <p><b>Subsequent Submittals:</b></p> <ul style="list-style-type: none"> <li>• Submit two (2) hard copies to the Payments and Submittals counter to be</li> </ul>	<p><b>Submittal Process:</b></p> <ul style="list-style-type: none"> <li>• Contact the Street Transportation Department to set up a scoping meeting.</li> <li>• Submit two (2) hard copies of the Traffic Impact Analysis to the Payments and Submittals Counter to be routed to Streets, filed under the KIVA number.                         <ul style="list-style-type: none"> <li>➤ Traffic impact analysis must be approved <b>prior</b> to submitting Master Street Plans to the Planning and Development Department.</li> <li>➤ Any proposed phasing shall be identified in the Traffic Impact Analysis and the Master Street Plans shall identify the phasing schedule along with correlating</li> </ul> </li> </ul>

Site Development Review:	Rezoning (including PUD) and General Plan Amendments	Master Plan(s) submittal for PCD Master Plan(s) submittal for PUD, where the gross land area is 320 acres in size or greater Master Plan(s) submittal per rezoning stipulation
	<p>routed to Streets and e-mail an electronic copy to the Street Transportation Department.</p> <ul style="list-style-type: none"> <li>Submit one (1) hard copy for the Village Planner along with an electronic copy.</li> </ul>	<p>improvements, as presented in the approved Traffic Impact Analysis.</p> <ul style="list-style-type: none"> <li>E-mail an electronic copy of the Traffic Impact Analysis to the Street Transportation Department.</li> </ul> <p><b>Subsequent Submittals:</b></p> <ul style="list-style-type: none"> <li>Submit two (2) hard copies to the Payments and Submittals counter to be routed to Streets and e-mail an electronic copy to the Street Transportation Department.</li> <li>Any proposed amendments to approved master street plans shall require that an updated Traffic Impact Analysis be submitted and approved <b>prior</b> to submitting new Master Street Plans.</li> </ul>
<p>Traffic Impact Analysis reports must be approved by the Street Transportation Department prior to submission of preliminary site plans with Planning and Development Department. All recommendations of the approved study shall be represented on the preliminary site plan.</p>	<p>It is at the discretion of the Street Transportation Department to require that the analysis be completed, and all associated improvements be identified, prior to the first recommendation Village Planning Committee meeting OR City Council Hearing. Otherwise, a Traffic Impact Analysis must be approved prior to submitting preliminary site plans.</p>	<p>Traffic Impact Analysis report and Master Street Plan must be approved by the Street Transportation Department prior to submission of preliminary site plans with Planning and Development Department. All recommendations of the approved study shall be represented on the Master Street Plan and the preliminary site plan.</p>

## 9.2 CITY OF PHOENIX TIA REQUIREMENTS

The Street Transportation Department reserves the right to require a traffic study, and its component scope, from any proposed development project in consideration of unique project elements, existing traffic operational or safety concerns, or reasonably anticipated operational challenges.

The City may require or request TIA submission to or from adjacent municipalities or agencies, in which controlling jurisdictions roadways or facilities may be affected. It is the responsibility of the submitter to coordinate these reviews and provide necessary approvals from municipalities or agencies prior to final TIA approval being granted.

### 9.2.1 Site Development Permits

Generally, any project that creates a subdivision of property, or a ground disturbance of at least 2,000 square feet, is routed to the Street Transportation Department for review. All such projects are evaluated for traffic study requirements. Where Street Transportation staff determine that a TIA is required, a stipulation will be indicated on the site plan review report. Refer to Chapter 5 of the City's Zoning Ordinance for additional information regarding site development requirements.

A TIA that is prepared for a site development will conduct the evaluation against observed traffic counts.

### 9.2.2 Zoning Applications

A TIA for a land entitlement/rezoning process will conduct the evaluation against observed traffic counts. In addition, the TIA will include an evaluation of the projected trip generation for the requested entitlement/rezoning, in comparison with projected trip from the current entitlement/rezoning. This comparison will demonstrate the net effect of the zoning/entitlement change. All applications for modifications of property entitlements require documentation of the expected change in vehicular trip generation to accompany the public review process of the zoning application. Certain zoning modification procedures require more well-defined TIA scope and timing for review and approval.

### 9.2.3 Planned Community Development (PCD)

Refer to Section 636 of the Zoning Ordinance for full procedural requirements. An approved traffic study is required prior to development of Master Street Plans. Projects at the PCD scale typically involve multiple parcels with phased installation of roadway infrastructure exceeding individual parcel frontages as necessary to support regional growth.

### 9.2.4 Planned Unit Development (PUD)

Refer to Section 671 of the Zoning Ordinance for full procedural requirements. The PUD model allows for flexible development standards that may not correspond to traditional land use categories. As such, a TIA is required with the initial application to inform the anticipated traffic impacts associated with the proposal. Street Transportation, in coordination with the Planning and Development Department, will determine whether TIA approval is required prior to setting City Council hearing dates.

### 9.2.5 Downtown Code, Walkable Urban Code, and Transit-Oriented Design Districts

Urban-focused districts require additional evaluation of the non-vehicular interface to public right-of-way. All studies within these districts must include analytical and/or narrative elements discussing active

modes considerations and the streetscape interface. The TIA must include a section addressing pedestrian considerations.

TIA recommendations must be consistent with the Downtown Code, Walkable Urban, or Transit-Oriented Development Zoning Districts. These include the use of alleyways and minimal use of driveway access points.

### 9.2.6 Guidelines for Traffic Study Scope

The scope of the TIA is commensurate with the number of trips to be generated by the development. Table 9.2-1 presents approximate ranges for anticipated vehicular trip generation by TIA analysis category. The appropriate scope must be discussed with the Street Transportation Department prior to commencing data collection or analysis. Projects that generate less than 100 peak-hour trips may *initially* submit a *traffic statement* that provides key information about the project for further evaluation. Street Transportation may accept the statement as fulfillment of the study requirement.

Table 9.2-1 Criteria for Determining TIA Study Requirements

Analysis Category	Development Characteristic	Study Horizons	Minimum Study Area
Traffic Statement	Single phase developments which generate < 100 peak hour trips during AM or PM per hour	-	-
I	Single phase developments which generate < 500* peak hour trips during the AM or PM peak hour  <i>Note: *200 peak hour trips for Downtown Code, Walkable Urban Code, or Transit-Oriented Development Code</i>	1. Opening year	1. Site access drives 2. Signalized and/or potential signalized intersections adjacent to development
II	Single phase or multi-phase developments which generate 500 or more peak hour trips but fewer than 1,000 trips during the AM or PM peak hour	1. Opening year 2. 5 years after opening	1. Site access drives 2. Signalized and/or potential signalized intersections within ¼ mile of development
III	Single phase or multi-phase developments which generate 1,000 or more peak hour trips but fewer than 1,500 trips during the AM or PM peak hour	1. Opening year 2. 10 years after opening	All site access drives Signalized and/or potential signalized intersections within ½ mile of development
IV	Multi-Phase developments (such as PCDs), and developments which generate more than 1,500 trips during the AM or PM peak hour	1. Opening year 2. Significant phases 3. 15 years after opening	Determined by the Street Transportation Department based on project size, location, and surrounding traffic conditions; typically, major intersections within one (1) mile of the development

a. Assume full occupancy and build-out for single-phase developments. Multi-phase developments may require assessment of multiple horizon year's corresponding to key phases as directed by the Street Engineering Department.

b. An enlarged study area may be required when the minimum study areas identified in 10.1 does not provide sufficient information to meet the intent of the Traffic Impact Study guidelines.

## 9.3 TRAFFIC IMPACT STUDY CONTENT

The following must be included in the Traffic Impact Study:

### 9.3.1 Required Sections

- **Introduction:** Describe the reason for the TIA, identify the project, and state its location. Identify the TIA Category.
- **Proposed Development:** Include information on location, land use, size, density, phasing, build-out year, access points, and any other relevant descriptions of the development.
- **Study Area:** Identify intersections and roadways analyzed within the report.
- **Surrounding Land Use:** Describe the existing land uses surrounding the development.
- **Surrounding Transportation System:** Describe the existing streets, intersections, transit, bike, and pedestrian facilities. Include information regarding planned improvements in the area not a part of the planned development.
- **Existing Traffic Counts:** State when, where, and how counts were collected. Include count data in the Appendix.
- **Analysis Time Periods and Study Horizon Years:** Document the peak hours to be analyzed within the report and all scenarios (existing, background, total, improved, etc.) to be analyzed.
- **Proposed Development Traffic:** Describe the trips to be generated by the proposed development and how the generated trips will be distributed to the street network.
  - ▶ **Trip Generation:** Document the estimated trips generated by the development using the Institute of Transportation Engineers (ITE) Trip Generation. Include the calculations in the Appendix.
  - ▶ **Trip Reductions:** Document Street Transportation Department approved trip reductions for internal capture, pass-by or mode split.
  - ▶ **Distribution:** Document the trip distribution of development trips based on the employment and population data for the study area. This can be done on a figure.
  - ▶ **Assignment:** Document the specific route trips will take to arrive at and depart from the development. This can be done on a figure.
- **Off-Site Future Traffic:** Describe the process utilized to calculate the growth rate and future traffic volumes in the study area.
- **Analysis:** Include the calculations for all analyses required by the Street Transportation Department (Level-Of-Service, auxiliary lanes, etc.). Document multimodal considerations and impacts.
- **Safety:** Discuss crash data and key findings of the crash analysis; sight distance, alignment of driveway/streets; speed; multimodal considerations.
- **Recommendations:** Identify any improvements necessary for safe and efficient operation of the transportation system. Identify multimodal considerations and recommendations.



### 9.3.2 Required Figures

- **Site Location:** Area map showing site location and area of influence.
- **Conceptual Plan of Proposed Development:** Land use components, access points for vehicular and pedestrian connections, and on-site circulation.
- **Surrounding Transportation System:** All major streets, minor streets adjacent to site, planned improvements not part of proposed development, transit, bicycle, and major pedestrian routes, right-of-way widths, and traffic signal locations.
- **Existing and Anticipated Area Development:** Existing and future land uses in area.
- **Existing Traffic Volumes:** Daily traffic volumes and peak-hour traffic volumes; turning movement counts for peak hours.
- **Distribution:** Portion (by percentages) of site traffic approaching and departing proposed development.
- **Site Traffic:** Daily traffic volumes and peak hour traffic volumes for each horizon year (if separate phasing is expected); turning movement counts for the peak hours.
- **Off-Site Future Traffic:** Daily traffic volumes and peak-hour traffic volumes for each scenario (horizon year); turning movements for peak hours.
  - ▶ Analysis scenarios (horizon years) analyzed in the report must be described such as *'Existing Traffic Volumes + Site Phase 1 Traffic Volumes'* and *'Year 2025 Traffic Volumes + Site Full Build-out Traffic Volumes'*; figures showing the total traffic volumes for each scenario and analysis time period.
- **Total Traffic:** Daily traffic volumes and peak hour traffic volumes for each scenario (horizon year); turning movements for peak hours.
- **Recommend Improvements:** Recommended geometrics, cross sections, and traffic control. Include phasing if applicable.

## 9.4 SPECIAL CONSIDERATIONS FOR TRAFFIC COUNTS

The City of Phoenix generally experiences reduced traffic volumes during summer months. Traffic counts collected during summer months, or for periods where schools are not in normal operation, should be adjusted by a seasonal factor between 0.90 and 0.95. Collected counts should be divided by the agreed on seasonal factor.

Projects with unique traffic patterns may include data collection from comparison sites, adjusted for relevant factors, such as square footage or number of operational units.

Street Transportation concurrence on modification factors should be obtained prior to conducting the study analysis.

- All data shall be collected in accordance with the ITE Manual of Traffic Engineering Studies or as directed by the Street Transportation Department.
- Traffic count data should be no more than two years old.

- Adjust counts for average conditions due to seasonal differences when necessary.
- Existing daily traffic volumes may be obtained from the Street Transportation Department's 'Average Weekday Traffic Flow' map or from our Traffic Count Section.
- The directional split should be based on existing conditions. In the case where existing peak traffic is not available, a 60/40 split should be used.
- The peak factor (K) should be based on existing conditions. If traffic data are not available, 7 percent of daily traffic should be used for the morning peak hour and 8 percent for the evening peak hour.

## 9.5 TRIP REDUCTIONS FOR PASS-BY AND/OR INTERNAL TRIPS

Trip reductions, if appropriate, may be applied subject to approval by the Street Transportation Department:

- The *ITE Trip Generation Manual, 10<sup>th</sup> Edition* introduced subcategories for land use codes corresponding to urban project settings. These categories are the preferred method for estimating internal capture and mode split reductions. Reductions for pass-by or diverted trips may be based on ITE data or documentation of similar case in type and location.
- Internal trip reductions should generally not exceed 5-10 percent. All applications of trip reductions require an affirmative justification. Internal trip reductions in excess of 10 percent require approval from Street Transportation prior to submittal of the study.

## 9.6 OFF-SITE FUTURE TRAFFIC

As applicable, growth rates, MAG projections, and/or other traffic studies in the area may be used.

If the proposed site is surrounded by future developments or developable land, the Street Transportation Department may require that these developments be considered when estimating future traffic volumes.

## 9.7 LEVEL-OF-SERVICE ANALYSIS

Level-of-service analyses must be performed for the analysis time periods for each study intersection and site access in accordance with the Highway Capacity Manual.

Each analysis scenario (horizon year) should be analyzed with and without recommended improvements. The level-of-service calculations will be included in the Appendix.

Level-of-service 'D' is the minimum acceptable level-of-service at both signalized and unsignalized intersections during the peak hours. Level-of-service 'D' may be achieved by increasing intersection capacity and/or reducing vehicular traffic demand.

A level-of-service 'E' may be acceptable during peak hours within the most densely developed sections of Phoenix with the approval of the Street Transportation Department.

When requested by the Street Transportation Department, additional traffic analyses should be included in the study, such as queuing, gap, and speed. For large commercial developments, an internal circulation plan inclusion is required.

## 9.8 AUXILIARY TURN LANES

### 9.8.1 Intersections

Auxiliary lanes (right-turn, left-turn lanes) at intersections are required when thresholds as presented in **Table 9.8-1** are expected to be met with the addition of the projected development traffic.

Thresholds presented in **Table 9.8-1** are consistent with those established by *Maricopa County Department of Transportation, Roadway Design Manual, Section 6.1.6 (February 2020)*.

Table 9.8-1 Intersection Auxiliary Turn Lane Criteria

Intersection Auxiliary Lane	Criteria
<b>Intersection Right-Turn Lane/Deceleration Lanes</b>	<p>Intersection right-turn lane is to be provided:</p> <ul style="list-style-type: none"> <li>▶ When the roadway has two approach through lanes, a posted speed limit of 45 mph or greater, and an expected right-turn peak hour volume of 300 vph or greater.</li> <li>▶ When the roadway has one approach through lane, a posted speed limit of 35 mph or greater, and an expected right-turn peak hour volume of 300 vph or greater.</li> <li>▶ On any roadway where a traffic impact analysis indicates the level-of-service would be increased to a level-of-service of D or better with the addition of a right-turn lane.</li> </ul> <p>In rural and developing urban areas with higher speeds, a separate right-turn lane may be required for lower right-turn volumes.</p>
<b>Intersection Left-Turn Lane</b>	<p>Intersection left-turn lane is to be provided:</p> <ul style="list-style-type: none"> <li>▶ At all signalized intersections.<sup>1</sup></li> <li>▶ When the left-turn movement into another roadway results in a level-of-service less than the minimum level-of-service of D during any peak hour.</li> </ul>
<b>Intersection Dual Left-Turn Lanes</b>	<p>Intersection dual left-turn lane is to be provided:</p> <ul style="list-style-type: none"> <li>▶ When the peak hour left-turn volume exceeds 300 vehicles per hour.</li> <li>▶ When the peak hour conflicting through movement volume exceeds 1,000 vehicles per hour.</li> <li>▶ When a traffic impact analysis indicates the level-of-service would be increased to a level-of-service of D or better with the addition of dual left turns.</li> </ul>

1. In some circumstances, left-turn lanes may not be required at signalized intersections; those intersections will generally require split phase signal operation and will be evaluated by the City on a case-by-case basis.

### 9.8.2 Site Driveways

#### Driveway Right-Turn Lane/Deceleration Lane

Right-turn/deceleration lanes may be required at driveways to assist traffic entering or exiting the roadway. The need for right-turn lanes to developments are based on criteria that consider traffic volume and street cross section as identified in **Table 9.8-2**. Street Transportation Department will indicate installation requirements based on the recommendations in consideration of the site context.

No driveways are to be located within deceleration lanes. Deceleration lanes will be constructed to serve individual driveways. No continuous lanes will be allowed to serve multiple driveways.

Table 9.8-2 Site Driveways Turn Lane Criteria

Driveway Auxiliary Lane	Arterial and Collector Roadway	Industrial/Freight Development
<b>Driveway Right-Turn Lane /Deceleration Lanes</b>	Driveway right-turn lane is to be provided when: <ul style="list-style-type: none"> <li>▶ The outside lane has an expected volume of 250 vph or greater and the right-turn volume is greater than 55 vph.</li> </ul> Or, when three of the following are met: <ul style="list-style-type: none"> <li>▶ 5,000 vehicles per day on the adjacent street.</li> <li>▶ Posted speed limit is greater than 35 mph.</li> <li>▶ 1,000 vehicles per day are expected to use the driveway.</li> <li>▶ At least 30 vehicles are expected to make right-turns into the driveway within a one-hour period.</li> </ul>	For large industrial or commercial developments with a significant percentage of truck traffic entering the site from a high-volume arterial, driveway right-turn deceleration lanes may be required at below the above-described criteria and will be evaluated on a case-by-case basis.  Auxiliary lanes will be required for all sites with 25 or more truck bays at all primary entrance route driveways.

### Driveway Left-Turn Lanes

Traffic volume warrants for adding a left-turn lane to an arterial or collector roadway are shown in **Table 9.8-3**. The volumes provided in **Table 9.8-3** are the minimum left-turn peak hour volume and minimum through volume in the same direction. A left-turn lane will be required if the left-turn peak hour volume is equal to or greater than the volume shown in **Table 9.8-3**.

Table 9.8-3 Volume Warrants for Auxiliary Left-Turn Lanes

Peak Hour Traffic Volume on the Roadway in the Advancing Direction	Minimum Peak Hour Left-Turn Traffic Volume			
	Number of Through Lanes Per Direction			
	1		2	
	< 45 mph Posted Speed	≥ 45 mph Posted Speed	< 45 mph Posted Speed	≥ 45 mph Posted Speed
≤ 200	30	15	-	-
201-300	12	12	40	30
301-400	12	12	30	25
401-500	12	12	25	18
501-600	12	12	15	12
601-1000	12	12	10	8
1001+	12	8	10	8

## 9.9 MITIGATION

Applicants will propose mitigations for all development action impacts that degrade modes to unacceptable performance levels or that generate travel demand in a way inconsistent with city goals.

Mitigation measures are identified by comparing Future Conditions with and without the proposed mitigation. A summary table of the Total Future analysis with the proposed mitigation measures, and for each phase of multi-phase developments will be presented and a map of the analysis results also be prepared.

### 9.9.1 Approach to Mitigation

The approach to mitigate vehicle trip impacts to the transportation network is to first establish optimal site design and operations to support efficient site circulation. When these efforts alone cannot properly mitigate an action's impact, reducing vehicle parking; implementing travel demand management (TDM) measures; and making upgrades to the pedestrian, bicycle, and transit networks to encourage use of non-auto modes shall be proposed.

In some instances, it may not be feasible to mitigate impacts to all modes. For example, established high-density areas typified by heavy vehicular traffic and constrained right-of-way will have few if any options for improving traffic operations. In these cases, the TIA must describe the challenges in mitigating impacts, with a focus on constrained right-of-way and negative secondary impacts on other modes. The Applicant shall instead explore and commit to other non-auto mitigations that have the potential to reduce demand for vehicular travel to the site. Performance monitoring may be appropriate in certain circumstances to ensure that a development's actual impacts do not exceed the impacts projected during zoning review and could require additional mitigation measures.

Any change required to the transportation network to reduce or minimize an action's impacts is considered "mitigation." All actions with proposed mitigation measures to be implemented over multiple phases will require the Applicant to commit to an implementation schedule by phase.

### 9.9.2 Non-Automotive Network Impacts

An assessment of non-automotive network impacts is required for sites within the Downtown Code, Walkable Urban, or Transit-Oriented Development Zoning Districts in support of the City's adopted Complete Street Ordinance.

Definitions for impacts to non-auto transportation networks and infrastructure are less quantitative than impacts to the roadway network. In general, any action is said to have an impact and requires mitigation if:

- It leads to overcrowding on infrastructure such as sidewalks, bike lanes, or transit service and facilities. This pedestrian or bicycle congestion may be measured via Highway Capacity Manual methodologies, other quantitative means (such as area of sidewalk per pedestrian, etc.), or shown via qualitative site and facility analysis; and
- There are any inadequate or missing pedestrian facilities, bicycle facilities, or transit stops in the vicinity of the site that are anticipated to be used by site-generated trips.
- The Following Sections should be considered and incorporated within the TIA in support of the City's adopted Complete Streets Ordinance.

### 9.9.3 Non-Automotive Network Enhancements

It is expected that the Applicant will fill gaps in the non-automotive network and fix substandard non-automotive facilities, as identified in the TIA. The Applicant should look for opportunities to upgrade site-adjacent and off-site pedestrian, bicycle, and transit facilities. The Applicant should focus particularly on improvements to facilities that link between the site and transit facilities, schools, parks, and other major activity centers.

### **9.9.4 Pedestrian Facilities**

When determining appropriate pedestrian mitigations, special attention should be paid to facilities that promote pedestrian safety. Examples include installing missing sidewalk segments, widening sidewalks, correcting non-ADA compliant curb ramps, removing right-turn slip lanes, refurbishing crosswalks and pedestrian signage, installing curb extensions to shorten wide pedestrian crossings, installing pedestrian signal heads, and planting new street trees. Improvements to the pedestrian network should be accessible for all users and encourage a reduction in speeds of vehicles which in turn reduces the likelihood of collision with a pedestrian or bicyclist as well as the severity of the crash. For larger projects, both internal and external pedestrian circulation should be considered.

### **9.9.5 Bicycle Facilities**

A principal impact for development projects on the stress of the bicycle network is the number and access condition of site driveways. For sites fronting an identified bicycle route, all reasonable efforts should be made to consolidate access locations, utilize shared access, and narrow site driveways. For larger projects, providing protected or conventional bike lanes and space for, or contributing to, a multi-use trail may be appropriate during the development process. Typically, on-street bicycle facilities are not required unless a project is large enough to cover an entire block or more. Smaller projects adjacent to City-planned bicycle lanes are expected to reserve space along the site frontage, as appropriate, to ensure the facility can be installed. However, an Applicant may be required as mitigation to upgrade facilities to a greater degree of cyclist protection where appropriate (i.e., converting conventional bicycle lanes to separated facilities by flipping the parking and bicycle lane).

### **9.9.6 Transit Facilities**

Improved access to and quality of Valley Metro bus stops and Light Rail stations should be considered for mitigation. Connections should be provided directly to building entrances, utilize distinct surface materials, and offer concentrated shade. Examples include coordinating with Valley Metro and the City on bus stop relocation to locations that are preferred for safety and operations, ensuring ADA-accessibility, electrification of bus shelters, and installation of real-time digital displays or new wayfinding signage.

### **9.9.7 Roadway Operational and Geometric Changes**

If traffic operation changes on a street are proposed (i.e., closing, direction change, reconfiguration of traffic lanes, etc.), analysis and clear rationale should be provided to support the change. In addition to operational changes, restrictions to site access points at other intersections may be appropriate, including turning and time-of-day restrictions. Restrictions may need to be reinforced through design elements, such as internal signage, physical barriers, or channelization identified in the project impact assessment phase.

The Street Transportation Department will review the proposed changes and determine if they are feasible, effective, and appropriate. The mitigations shall be designed to sufficient detail for the City to evaluate their potential effectiveness. Proposals for widening roads or installing turn lanes must be accompanied by a right-of-way analysis to determine if the available right-of-way can accommodate the proposed mitigation, along with impacts to existing street trees and on-street parking. Preliminary engineering may be needed to determine the feasibility of proposed changes.

### 9.9.8 Intersection Control

For all intersections where the Applicant is proposing a change in intersection control, such as converting an existing two-way stop control intersection to all-way stop control, an assessment of appropriate traffic control shall be performed. Refer to Section 2.7 of this manual.

Traffic signal warrant analyses, as established by the MUTCD, should be provided for site access locations and adjacent intersections that demonstrate operational degradation.

Warrant analysis shall be included for any arterial/arterial or arterial/collector intersection within the study area. Additional intersections may be subject to warrant evaluation based on the engineer's judgement or by request of the Street Transportation Department.

Satisfaction of warrant criteria is not the sole consideration for a recommendation or requirement to install a traffic signal as identified in a study. Proportional funding may be required regardless of warrant satisfaction due to considerations, such as existing master plans prepared by prior development and location of collector street intersections anticipated to meet signal warrants for time horizons beyond the scope of the development's study.

Development projects may be required to install underground traffic signal infrastructure, such as conduits and junction boxes, with corresponding off-site improvements due to the efficiencies gained in limiting future excavation work.

If the proposed traffic control device is a traffic signal, Pedestrian Hybrid Beacon (PHB) (Figure 9.9-1), also referred to as a HAWK, or Rectangular Rapid Flashing Beacon (RRFB) and is primarily driven

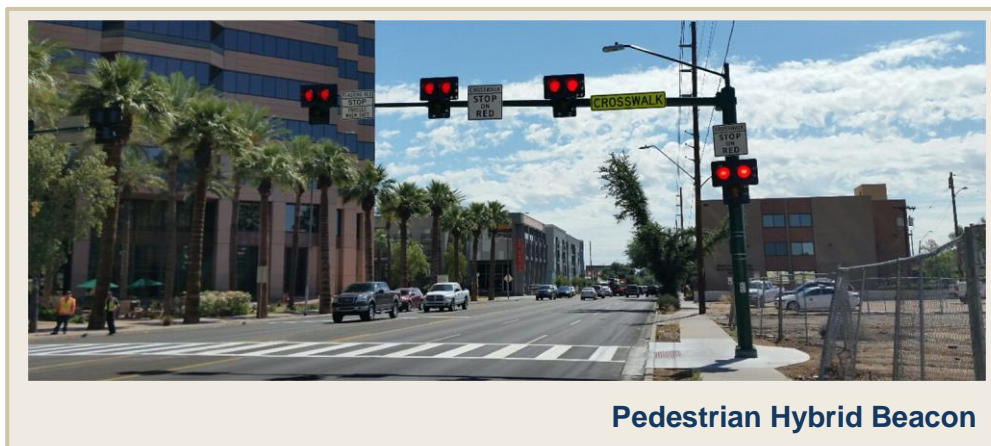

**Pedestrian Hybrid Beacon**

*Figure 9.9-1 Pedestrian Hybrid Beacon*

conditions anticipated by the "Total Future" scenario, the Applicant will be required to provide a traffic control justification in support of the recommendations. The justification shall include future traffic volume analysis of the threshold necessary to reach the signal warrant thresholds.

Development funding responsibilities will be identified in the response letter provided by the Street Transportation upon final review of a study, or as stipulations provided to site development or zoning application review reports.

# REFERENCES

## CHAPTER 2

### 2.1 Introduction

*AASHTO A Policy on Geometric Design of Highways and Streets, 7<sup>th</sup> Edition, 2018, Section 1.8 Design Flexibility, p. 1-32*

#### **2.1.3 Right-of-way Zones**

City of Phoenix, Key Corridors Master Plan

City of Phoenix Bicycle Master Plan

*City of Seattle, Right-of-Way Improvements Manual, Standard 2.1 Right-of-Way Allocation*

### 2.3 Travel Lanes Zone

City of Phoenix, Key Corridors Master Plan

#### **2.3.1 Design Speed**

*NACTO Urban Street Design Guide, 2013, p. 141*

*AASHTO A Policy on Geometric Design of Highways and Streets, 7<sup>th</sup> Edition, 2018, p. 2-24*

#### **2.3.2 Design Vehicle**

*AASHTO A Policy on Geometric Design of Highways and Streets, 7<sup>th</sup> Edition, 2018, Section 2.8 Design Vehicles, pp. 2-55 to 2-85*

*NACTO Urban Street Design Guide, 2013, p. 144-146*

#### **2.3.3 Street Section Elements**

*City of Phoenix Street Transportation Department, Traffic Operations Manual, Chapter 4, Pavement Narrowing Treatments, p. 144-145*

*Maricopa County 2018 Roadway Design Manual, Section 5.20.1, Narrowing Transitions*

#### **2.3.6 Turn Lanes**

*MCDOT, Roadway Design Manual, 2018, p. 6-5*

#### **2.3.7 Medians**

*City of Phoenix Parks and Recreation Department, 2006 Street Landscape Standards*

*City of Phoenix Street Planning and Design Guidelines 2009*

*MAG Left-Turn Crash Mitigation Implementation Template and Guidance, May 2018, p. 3-8*



**2.3.8 Curb Type**

*2009 City of Phoenix Street Planning and Design Guidelines, Sections 3.5.4 Curb Returns, p. 3-7 and p. 3-8.*

*MAG Standard Specifications for Public Works Construction, 2019 Revision to the 2015 Edition, Sections 340: Concrete Curb, Gutter, Sidewalk, Curb Ramps, Driveway and Alley Placement, pp. 340-1 to 340-5*

*2015 City of Phoenix Supplement to the 2015 Edition MAG Uniform Standard Specifications for Public Works Construction, Section 340, Concrete Curb, Gutter, Sidewalk, Curb Ramps, Driveway and Alley Entrance and Section 401 (G), Pedestrian Access Requirements*

*2021 City of Phoenix Supplemental Standard Details for Public Works Construction, Detail P1230, Sidewalks*

*City of Phoenix Administrative Procedure No 155, Project Development Requirements and Guidelines, February 2012, p. 16*

**2.3.9 Horizontal Alignments**

*AASHTO, A Policy on Geometric Design of Highways and Streets, 7<sup>th</sup> Edition, 2018, pp. 3-120, 3-121, and 9-32*

**2.3.10 Vertical Alignment**

*AASHTO, A Policy on Geometric Design of Highways and Streets, 7<sup>th</sup> Edition, 2018, pp. 3-167, 3-171, 3-173*

**2.3.11 Alignment Sight Distance**

*AASHTO, A Policy on Geometric Design of Highways and Streets, 7<sup>th</sup> Edition, 2018, Section 3.2.6.2*

Superelevation

*AASHTO, A Policy on Geometric Design of Highways and Streets, 7<sup>th</sup> Edition, 2018, p. 2-24*

**2.4 Flex Zone****2.4.1 Bicycle Facilities**

*Arizona Revised Statute 28-815, Riding on roadway and bicycle path; bicycle path usage*

*City of Phoenix Street Transportation Department, Traffic Operations Handbook— Chapter 5 Bicycle Facilities, pp. 167 - 168*

**2.4.2 On-Street Parking**

*City of Phoenix Zoning Ordinance 662, Interim Transit-Oriented Zoning Overlay District 1 (TOD-1), Section L, Parking and Loading Regulations*

*City of Phoenix Zoning Ordinance 663, Interim Transit-Oriented Zoning Overlay District 2 (TOD-2), Section L, Parking and Loading Regulations*

### **2.4.3 Transit**

*Valley Metro Light Rail Transit Projects LRT Design Criteria Manual, January 2018, p. 3-20*

*MAG Uniform Details for Public Works Construction, 2019 Revision to the 2015 Edition, Standard Detail 252, Bus Bays*

*NACTO Transit Street Design Guide, pp. 70 – 81*

*City of Phoenix Street Transportation Department, Traffic Operations Manual, Chapter 14, Bus Stop Signing, pp. 420-421*

*Valley Metro Light Rail Transit Projects LRT Design Criteria Manual, January 2018, p. 3-20*

*City of Phoenix Standard Details*

P1256-1 Bus Bay (Type 1)

P1256-2 Bus Bay (Type 2)

P1258 bus shelter pad location (bus stop)

P1260 bus shelter/accessory pad bus stop

P1261 bus shelter/accessory pad bus bay

P1262 parkway bus shelter/accessory pad

P1263-1 bus shelter/accessory pad frontage road mid-block

P1263-2 parkway bus shelter/accessory pad

## **2.5 Pedestrian Zone**

### **2.5.1 Sidewalks**

*City of Phoenix Administrative Procedures No. 155, Project Development Requirements and Guidelines*

## **2.6 Intersections**

### **2.6.2 Intersection and Driveway Sight Distance**

*City of Mesa Engineering and Design Standards, 2017, Section 211, Sight Distance and Visibility, pp. 29-30, 43*

*AASHTO, A Policy on Geometric Design of Highways and Streets, 7<sup>th</sup> Edition, 2018*

## **2.7 Roundabouts**

*NCHRP Report 672, Roundabouts: An Informational Guide, Second Edition, 2010*

*City of Phoenix Street Transportation Department, Traffic Operations Manual, Chapter 9, Traffic Circle/Roundabout Signing and Pavement Markings, p. 220-221*

## **CHAPTER 3**

### **3.1 Introduction**

#### **3.1.2 Definitions**

*MAG Standard Specifications for Public Works Construction, 2019 Revisions to the 2015 Edition*

### 3.1.3 Geotechnical Investigation Requirements

*City of Phoenix Street Transportation Department Design and Construction Management Division, Administrative Procedure (AP) No. 155, Project Development Requirements and Guidelines, pp. 26-28*

*MAG Standard Specifications for Public Works Construction, 2019 Revisions to the 2015 Edition*

### 3.1.3 Design Parameters

*AASHTO Guide for Design of Pavement Structures*

*ADOT Standard Drawing C-05.40, Median Paving and Nose Taper*

*City of Phoenix Ordinance, Section 32 – 26 (k)*

## **3.3 Bridges and Major Structural Plans**

### 3.3.1 Bridges

*AASHTO Standard Specifications for Highway Bridges, 17<sup>th</sup> Edition, 2002*

*AASHTO LRFD Bridge Design Specifications*

*AASHTO LRFD Bridge Construction Specifications, 4<sup>th</sup> Edition, 2017 with March 2018 errata*

*AASHTO LRFD Bridge Design Specifications, 8<sup>th</sup> Edition, 2017*

*ADOT Bridge Design Guidelines*

[\(<https://www.azdot.gov/business/engineering-and-construction/bridge>\)](https://www.azdot.gov/business/engineering-and-construction/bridge)

*ADOT Standard Specifications for Road and Bridge Construction*

*City of Phoenix Administrative Procedure (AP) No. 155 Project Development Requirements and Guidelines, pp. 52-53*

*City of Phoenix Storm Water Policies and Standards Manual*

[\(<http://phoenix.gov/STREETS/index.html>\)](http://phoenix.gov/STREETS/index.html)

### 3.3.2 Structural Clearances

*AASHTO A policy on Geometric Design of Highways and Streets, 2018, p. 7-8 (clear zones for rural arterials), p. 7-9 and 7-51 (rural and urban arterial vertical clearance), p. 7-49 (clear zone for urban arterials), p. 6- 21 (urban collectors), p. 6-20 (vertical clearance urban collectors), p. 6-8 (clear zones and vertical clearance for rural collectors) p. 5-23 (clear zone for urban local streets), p. 5-10 (clear zones for rural local streets), 5-9 (vertical clearance for rural local roads)*

*AASHTO Roadside Design Guide, 4<sup>th</sup> Edition, 2011, Chapter 3, Roadside Topography and Drainage Features*

*Manual of Uniform Traffic Control Devices, Section 4D.16*

## **3.4 Cut or Fill Slopes**

*AASHTO Roadside Design Guide, 4<sup>th</sup> Edition, 2011, Chapter 3, Roadside Topography and Drainage Features*

*City of Phoenix Administrative Procedure No. 155, Project Development Requirements and Guidelines, 2012, p. 46*

### **3.5 Pavement Transitions**

*City of Phoenix Street Transportation Department, Traffic Operations Manual, Chapter 4, Pavement Narrowing Treatments, pp. 144-145*

*Maricopa County 2018 Roadway Design Manual, Section 5.20.1, Narrowing Transitions*

### **3.6 Stormwater Management**

*City of Phoenix Storm Water Policies and Standards, 3<sup>rd</sup> Edition, December 2013,*  
<https://www.phoenix.gov/waterservicessite/Pages/STORMWATER-Construction.aspx>

*City of Phoenix Drainage Design Management System for Windows (Phoenix – DDMSW)*

### **3.7 Green Infrastructure**

*Greater Phoenix Metro Green Infrastructure and Low Impact Development (LID) Handbook (2019)*

*MAG Uniform Standard Specifications for Public Works Construction, Section 323, Placement of Pervious Concrete and Section 723, Pervious Concrete*

### **3.8 Right-of-way Management Procedures**

*City of Phoenix Traffic Barricade Manual, 9<sup>th</sup> Edition, 2017*

*City Manager's Construction Project Map*

## **CHAPTER 4**

### **4.2 Traffic Signal Design**

*City of Phoenix Standard Traffic Signal Details*

*City of Phoenix Street Transportation Department, Traffic Operations Manual, 2018, Chapter 12, Traffic Signals*

*U.S. Department of Transportation Federal Highway Administration, Manual on Uniform Traffic Control Devices for Streets and Highways (MUTCD), 2009*

*Arizona Supplement to the Manual on Uniform Traffic Control Devices, 2009*

#### **4.2.3 Traffic Design Reference**

##### **Developer Costs and Escrow Account**

*City of Phoenix Street Transportation Department, Traffic Operations Manual, 2018, Chapter 12, Traffic Signals*

##### **Maintenance of Traffic**

*City of Phoenix Traffic Barricade Manual, 9<sup>th</sup> Edition, 2017*

### **4.3 Pavement Markings and Signing Plans**

#### **4.3.3 Signing**

*City of Phoenix Street Transportation Department, Traffic Operations Manual, 2018, Chapter 13, Traffic Signs*

*U.S. Department of Transportation Federal Highway Administration, Manual on Uniform Traffic Control Devices for Streets and Highways (MUTCD), 2009*

*Arizona Supplement to the Manual on Uniform Traffic Control Devices, 2009*

#### **4.3.4 Pavement Markings**

*City of Phoenix Street Transportation Department, Traffic Operations Manual, 2018, Chapter 4, Pavement Markings*

*U.S. Department of Transportation Federal Highway Administration, Manual on Uniform Traffic Control Devices for Streets and Highways (MUTCD), 2009*

*Arizona Supplement to the Manual on Uniform Traffic Control Devices, 2009*

## **CHAPTER 6**

### **6.4 Access Management Summary**

#### **6.4.3 Access Management Guidelines Summary**

*Transportation Research Board Access Management Manual, Second Edition, 2014*

### **6.7 Driveways**

*City of Phoenix Supplemental Standard Details for Public Works Construction (2021):*

- No. P1243: Return Type Driveways with Attached Sidewalk
- No. P1243-1: Limited Access Driveway with No LT-In and without Deceleration Lane
- No. P1243-2: Limited Access Driveway with No LT-In/Out and without Deceleration Lane
- No. P1243-3: Limited Access Driveway with No LT-In and with Deceleration Lane
- No. P1243-4: Limited Access Driveway with No LT-In/Out and with Deceleration Lane
- No. P1244: Driveway-Pedestrian Ramp Combination (For use at T type intersections)
- No. P1255-1: Driveway Entrance – Type I (Sidewalk Adjacent to Curb)
- No. P1255-2: Driveway Entrance – Type II (Detached Sidewalk)
- No. P1255-3: Driveway Entrance – ADA Retrofit
- No. P1255-4: Driveway Widths Policy

*City of Phoenix Supplement to the 2015 MAG Uniform Standard Specifications for Public Works Construction: Section 340, Concrete Curb, Gutter, Sidewalk, Curb Ramps, Driveway, and Alley Entrance*

*MAG Standard Detail 250-1 Driveway Entrances with Attached Sidewalk*

*MAG Standard Detail 250-2 Driveway Entrances with Sidewalk attached to Curb MAG Standard Detail No. 251 – Return Type Driveways*

## **6.8 Auxiliary Turn Lanes**

*City of Phoenix Supplemental Standard Details for Public Works Construction (2021):*

No. P1018: Alley Access Road Termination at Alleys

No. P1164: Maximum Driveways and Alleys Slope

*City of Phoenix Supplement to the 2015 MAG Uniform Standard Specifications for Public Works Construction:*

Section 340, Concrete Curb, Gutter, Sidewalk, Curb Ramps, Driveway, and Alley Entrance

*City of Phoenix Planning and Development Department, Downtown Alley Activation Program Policy, Revision 9/2017,*

*[https://www.phoenix.gov/pddsit/Documents/TRT/dsd\\_trt\\_pdf\\_00145.pdf#search=Downtown%20Alley%20Activation%20Policy](https://www.phoenix.gov/pddsit/Documents/TRT/dsd_trt_pdf_00145.pdf#search=Downtown%20Alley%20Activation%20Policy)*

*City of Phoenix Planning and Development Department, Gated Alley Program (GAP), FAQs, December 2018, [https://www.phoenix.gov/pddsit/Documents/PZ/pdd\\_pz\\_pdf\\_00455.pdf](https://www.phoenix.gov/pddsit/Documents/PZ/pdd_pz_pdf_00455.pdf)*

*City Code, 32-27, Street Design*

*City of Phoenix Supplemental Standard Details for Public Works Construction (2021):*

No. P1258: Bus Shelter Pad Location (Bus Stop)

## **CHAPTER 8**

*Manual of Uniform Traffic Control Devices, and adopted revisions, Arizona Supplement*

*American Association of State Highway and Transportation Officials (AASHTO) Guide for the Development of Bicycle Facilities, current version*

*National Association of City Transportation Officials (NACTO) Urban Bikeway Design Guide, most current version. NACTO has prepared additional guidance documents relevant to bikeway design that should be referenced.*

*MAG Active Transportation Plan and Toolbox, 2020*

*MAG Uniform Standard Specifications for Public Works Construction*

*City of Phoenix Active Transportation Plan*

*City of Phoenix Trails Master Plan*

*City of Phoenix Supplement to MAG Uniform Standard Specifications*

*City of Phoenix Complete Streets Policy and Complete Streets Design Guidelines*