

GENERAL NOTES:

- 1 The contractor shall notify the City Of Phoenix Traffic Signal Shop ((602) 262-6733) a minimum of fourteen (14) calendar days prior to beginning any traffic signal work. Submittals of all equipment shall be furnished to the Signal Shop and approved prior to the ordering of any traffic signal equipment. The Contractor shall verify that they have the most current set of drawings prior to start and ordering of any equipment.
- 2 The Contractor shall layout all ADA ramps, junction boxes and foundation locations for approval by the traffic signal representative prior to any excavation.
- 3 The Contractor shall provide and install all traffic signal items as shown on the approved traffic signal plans.
- 4 Foundation elevations must be within 1/4" of finished sidewalk grade.
- 5 A minimum of four (4) feet of clearance is required between all traffic signal poles and the back edge of sidewalk pedestrian ramps.

F.H.W.A. REGION	STATE	PROJ. NO.	NO.	TOTAL
9	ARIZ.			
DR:	DES:	CK:	DATE:	

TRAFFIC SIGNAL STANDARD DETAILS INDEX

POLES

SHEET NO.	DESCRIPTION	APPROVED
TS1 - 1	Type SQ Pole, Mast Arms and Mast Arm Extensions	05-08-2017
TS1 - 2	Type SR Pole, Mast Arms and Mast Arm Extensions	05-08-2017
TS1 - 3	Type SM Pole, Mast Arms and Mast Arm Extensions	05-08-2017
TS1 - 4	Type LM Pole and Risers	05-08-2017
TS1 - 5	Type G Pole, Luminaire Mast Arm	12-12-2017
TS1 - 6	Type A and PB (Pushbutton) Poles	09-01-2017
TS1 - 7	Loads for Poles, Mast Arms Signal Equipment	09-01-2017

JUNCTION BOXES AND FOUNDATIONS

SHEET NO.	DESCRIPTION	APPROVED
TS2 - 1	Junction Boxes, Foundations for Controller and Power Service Pedestal	04-01-2019
TS2 - 2	Pole Foundations	04-01-2019

SIGNAL EQUIPMENT DETAILS

SHEET NO.	DESCRIPTION	APPROVED
TS3 - 1	Mounting Details - Side Mount Signal Equipment	08-01-2014
TS3 - 2	Traffic Signal Head Graphic Detail	04-01-2019
TS3 - 3	HAWK Pedestrian Crossing Beacon - Dual Mast Arm	04-01-2019
TS3 - 4	HAWK Pedestrian Crossing Beacon - Single Mast Arm	04-01-2019
TS3 - 5	HAWK Pedestrian Crossing Beacon - Pole Configuration	04-01-2019

WIRING

SHEET NO.	DESCRIPTION	APPROVED
TS4 - 1	Wire Code Tables	04-01-2019
TS4 - 2	Pull Box/Pole Hand Hole Wiring	04-01-2019
TS4 - 3	Color Coding/Banding Scheme, Loop Numbering	08-01-2016

DETECTION

SHEET NO.	DESCRIPTION	APPROVED
TS5 - 1	Detection Loops	05-08-2017

PUSH BUTTON DETAIL

SHEET NO.	DESCRIPTION	APPROVED
TS6 - 1	Clear Space	04-01-2019
TS6 - 2	Apron Joints, Single Curb Ramp, and Limited Right-Of-Way	04-01-2019
TS6 - 3	Mid-Block	04-01-2019

SPECIAL USE POLES

SHEET NO.	DESCRIPTION	APPROVED
S1	Verizon SR Comm Signal Pole - Pole Details	10-31-2014
S2	Verizon SR Comm Signal Pole - Foundation Details	10-31-2014
S1	Verizon SM Comm Signal Pole - Pole Details	10-31-2014
S2	Verizon SM Comm Signal Pole - Pole Details	10-31-2014
S1	Verizon LM Comm Signal Pole - Pole & Foundation Details	10-31-2014

"PER CITY OF PHOENIX CITY CODE CHAPTER 2, SECTION 2-26, THESE PLANS ARE FOR OFFICIAL USE ONLY & MAY NOT BE SHARED WITH OTHERS EXCEPT AS REQUIRED TO FULFILL THE OBLIGATIONS OF YOUR CONTRACT WITH THE CITY OF PHOENIX."

CITY OF PHOENIX, ARIZONA
STREET TRANSPORTATION DEPARTMENT
TRAFFIC SIGNAL STANDARD DETAILS

INDEX SHEET

TPP File Number: 10164 DATE: 4-1-2019

TRAFFIC SERVICES ENGINEER

TRAFFIC SIGNAL DETAIL INDEX

CITY OF PHOENIX, ARIZONA
STREET TRANSPORTATION DEPARTMENT

PROJECT #:

DR:	DES:	CK:	SHEET NO:	TOTAL SHEETS
DATE:	DATE:	DATE:		

SCALE: QS. #:

DETAIL INDEX:

PROJECT #:

MAST ARM STAGE PIPE DIAMETER			
PRIMARY MAST ARM LENGTH	COLUMN A	COLUMN B	COLUMN C
40'	12 3/4" O.D. X 0.312 X 13'-4" (42 KSI)	10 3/4" O.D. X 0.25 X 13'-4" (42 KSI)	8 5/8" O.D. X 0.25 X 10'-1" (42 KSI)

F.H.W.A. REGION	STATE	PROJ. NO.	NO.	TOTAL
9	ARIZ.			

- NOTES:**
- DESIGN IN ACCORDANCE WITH AASHTO "STANDARD SPECIFICATIONS FOR STRUCTURAL SUPPORTS FOR HIGHWAY SIGNS, LUMINAIRES, AND TRAFFIC SIGNALS", 5TH EDITION, 2009.
 - PIPE SHALL HAVE MINIMUM YIELD STRENGTH SPECIFIED.
 - ALL OTHER STEEL SHALL HAVE A MINIMUM YIELD STRENGTH OF 36 KSI.
 - WELDING SHALL BE WITH E-70 LOW HYDROGEN RODS AND SHALL CONFORM TO AWS D1.1 LATEST EDITION.
 - POLE AND ARM SHALL BE POWDER COATED PER CITY SPECIFICATIONS.
 - INCLUDE ALL HANDHOLE COVERS W/ 2 EA. 1/4"-20 55 MACHINE SCREWS.
 - 'SQ' POLE CAN SUPPORT THE 55', # 60' MAST ARMS AS SHOWN.
 - 'SQ' POLE IS NOT COMPATIBLE WITH OTHER MAST ARMS.
 - ALL EQUIPMENT SHALL BE PERMANENTLY LABELED WITH MANUFACTURERS NAME, MONTH, DAY, YEAR MANUFACTURED AND EQUIPMENT TYPE.

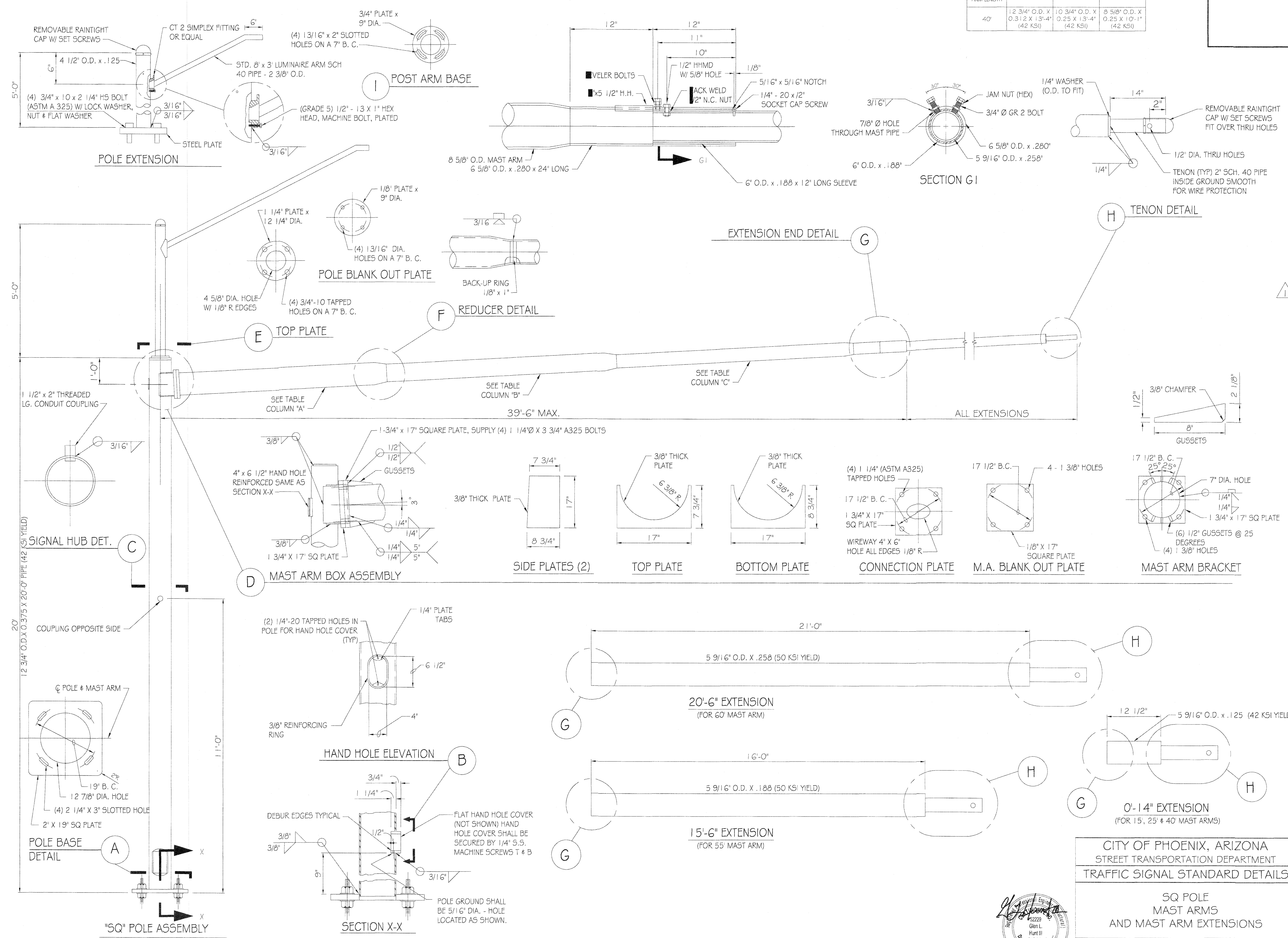

PER CITY OF PHOENIX CITY CODE CHAPTER 2, SECTION 2-28, THESE PLANS ARE FOR OFFICIAL USE ONLY & MAY NOT BE SHARED WITH OTHERS EXCEPT AS REQUIRED TO FULFILL THE OBLIGATIONS OF YOUR CONTRACT WITH THE CITY OF PHOENIX.

TRAFFIC SIGNAL DETAILS

CITY OF PHOENIX, ARIZONA
STREET TRANSPORTATION DEPARTMENT

SQ POLE MAST ARMS AND MAST ARM EXTENSIONS

TPP File Number: 10164 TS 1-1

DATE: 5-8-2017

SCALE: Q5 #:

PROJECT #:

DR: DES: CK: SHEET NO: TOTAL SHEETS

REVISION #	DATE	REVISION	DRAWN BY	APPROVED BY
1	5/8/2017	Added note #9	ZR	[Signature]

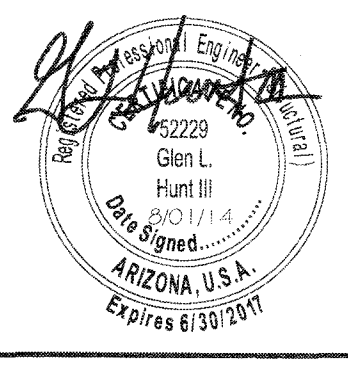

F.H.W.A. REGION	STATE	PROJ. NO.	NO.	TOTAL
9	ARIZ.			

DR: DES: CK: DATE:

PRIMARY MAST ARM LENGTH	MAST ARM STAGE PIPE DIAMETER		
	COLUMN A	COLUMN B	COLUMN C
15'	6 5/8" O.D. X 0.156 X 6'-4" (42 KSI)	6 5/8" O.D. X 0.156 X 6'-0" (42 KSI)	
25'	6 5/8" O.D. X 0.188 X 13'-4" (56 KSI)	6 5/8" O.D. X 0.156 X 8'-8" (56 KSI)	
40'	10 3/4" O.D. X 0.250 X 13'-4" (46 KSI)	8 5/8" O.D. X 0.250 X 13'-4" (46 KSI)	6 5/8" O.D. X 0.250 X 10'-1" (52 KSI)

- NOTES:**
- DESIGN IN ACCORDANCE WITH AASHTO 'STANDARD SPECIFICATIONS FOR STRUCTURAL SUPPORTS FOR HIGHWAY SIGNS, LUMINAIRES, AND TRAFFIC SIGNALS', 5TH EDITION, 2009.
 - PIPE SHALL HAVE MINIMUM YIELD STRENGTH SPECIFIED.
 - ALL OTHER STEEL SHALL HAVE A MINIMUM YIELD STRENGTH OF 36 KSI.
 - WELDING SHALL BE WITH E-70 LOW HYDROGEN RODS AND SHALL CONFORM TO AWS D1.1 LATEST EDITION.
 - POLE AND ARM SHALL BE POWDER COATED PER CITY SPECIFICATIONS.
 - INCLUDE ALL HANDHOLE COVERS W/ 2 EA. 1/4"-20 55 MACHINE SCREWS.
 - 'SR' POLE CAN ONLY SUPPORT UP TO A 50' MAST ARM.
 - ALL EQUIPMENT SHALL BE PERMANENTLY LABELED WITH MANUFACTURERS NAME, MONTH, DAY, YEAR MANUFACTURED AND EQUIPMENT TYPE.

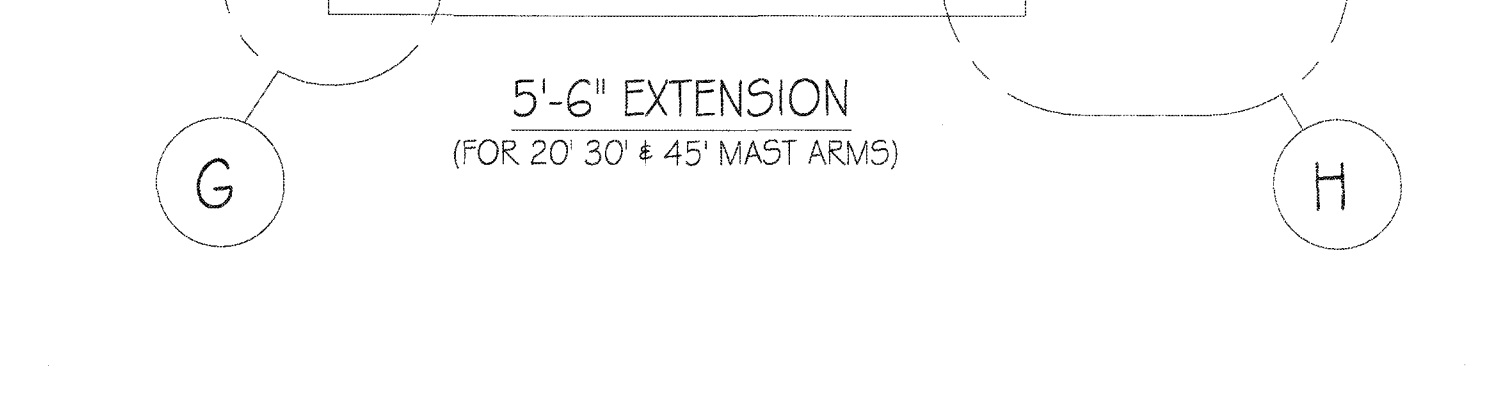
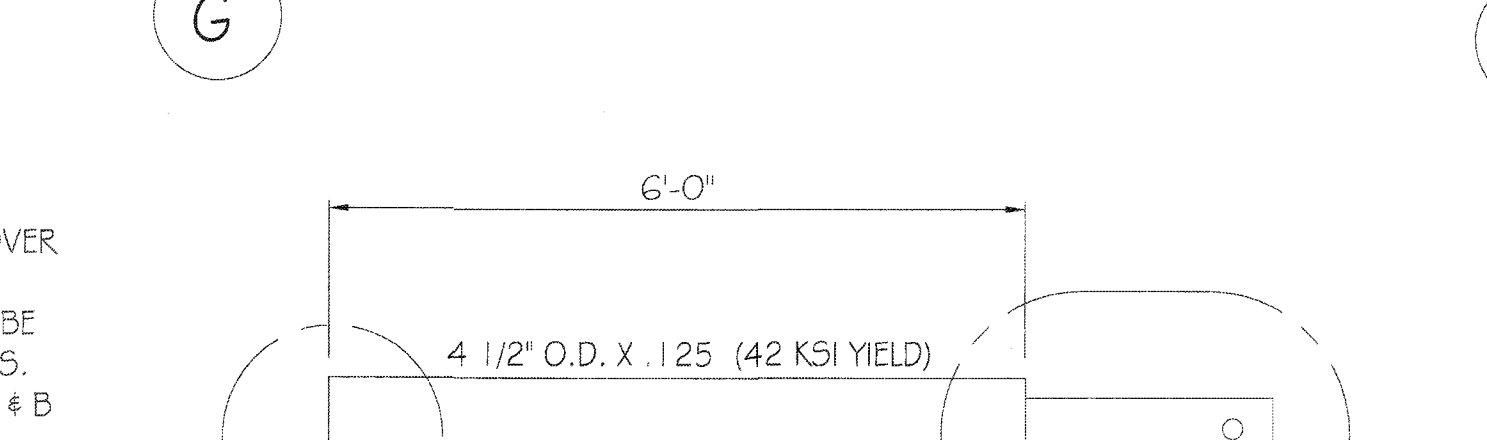
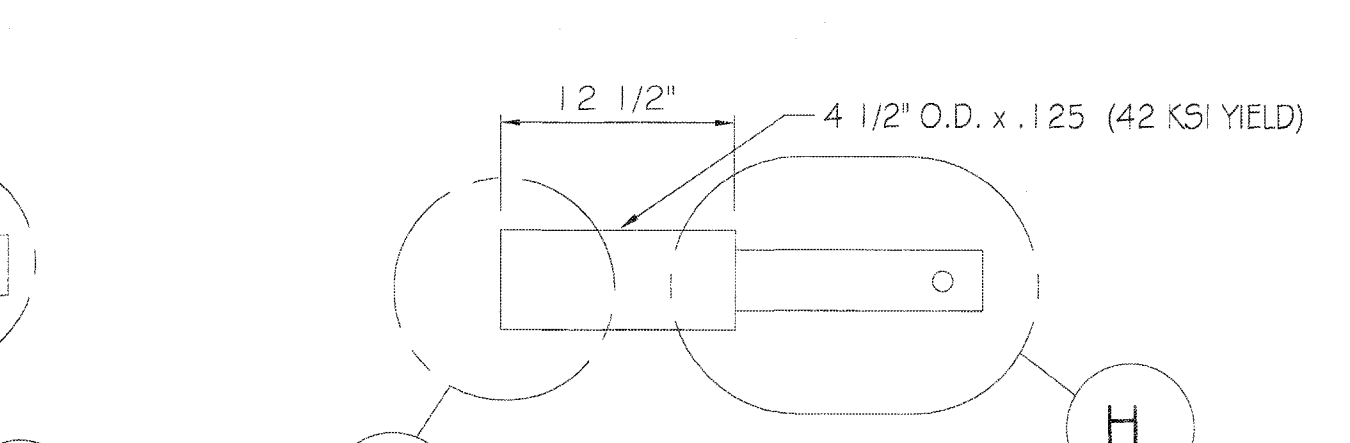
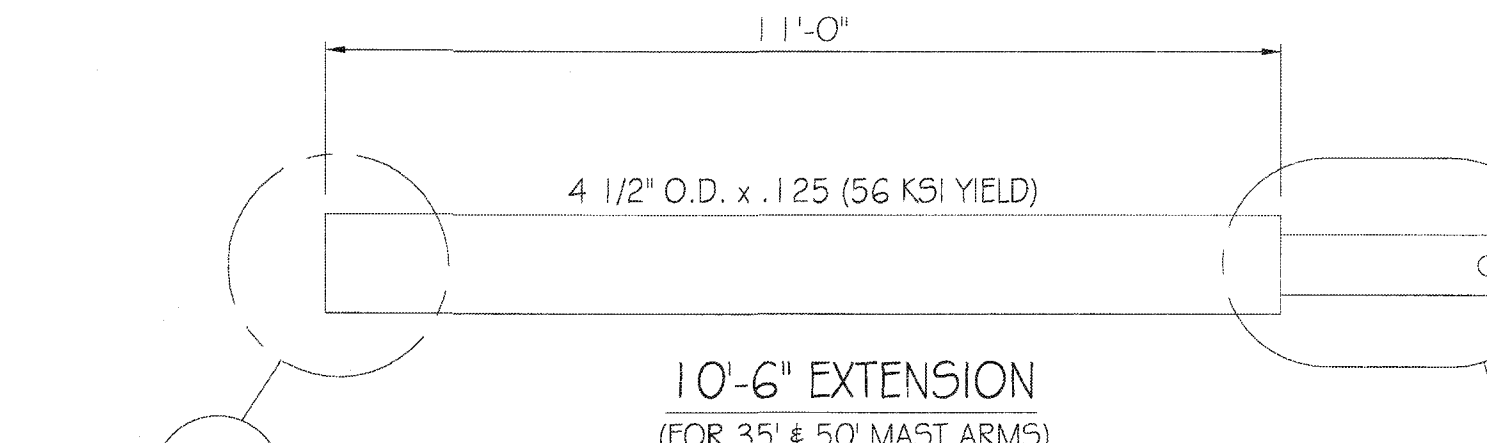
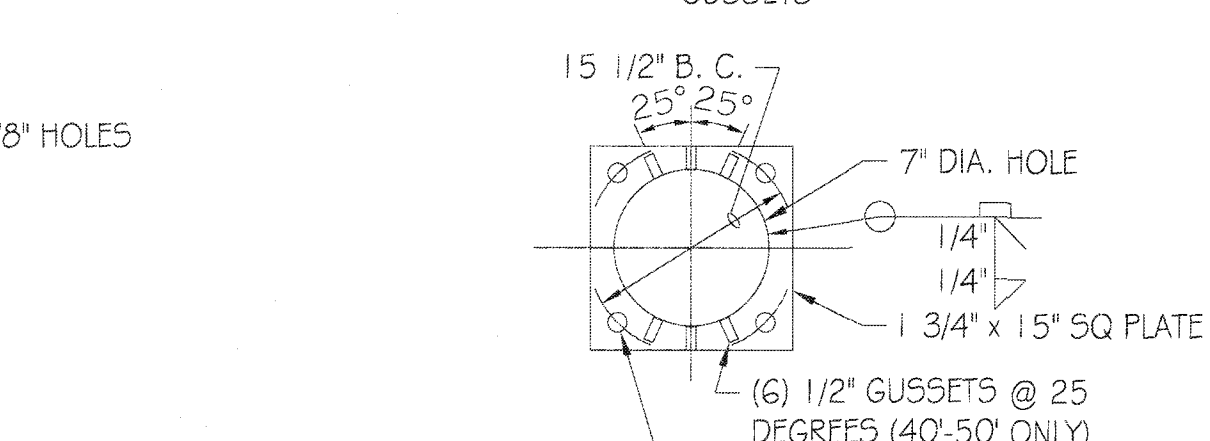
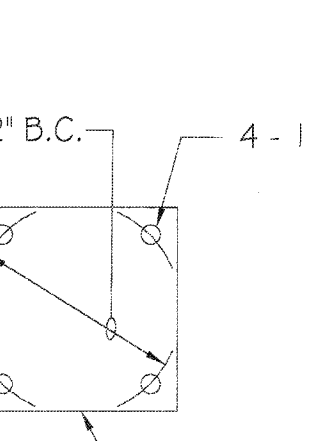
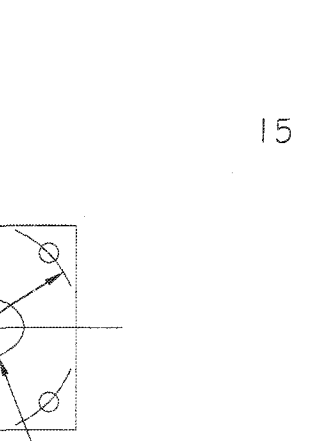
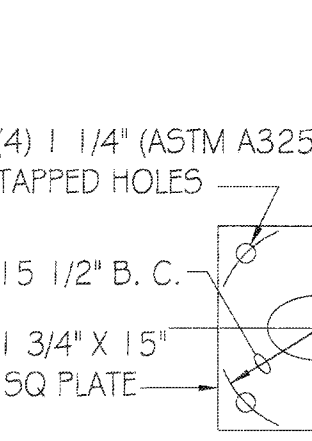
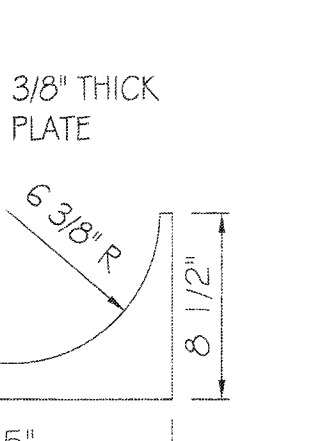
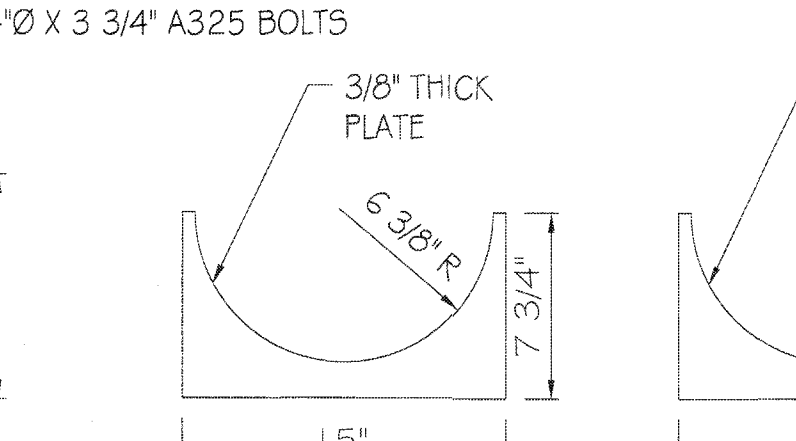
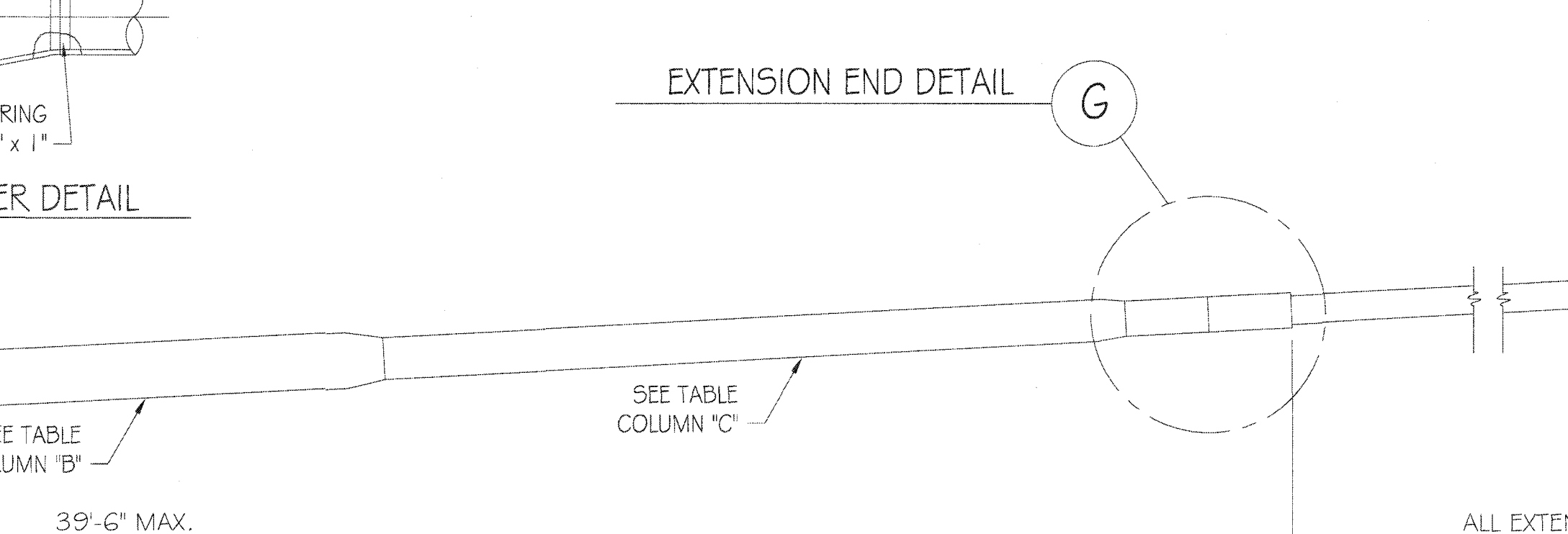
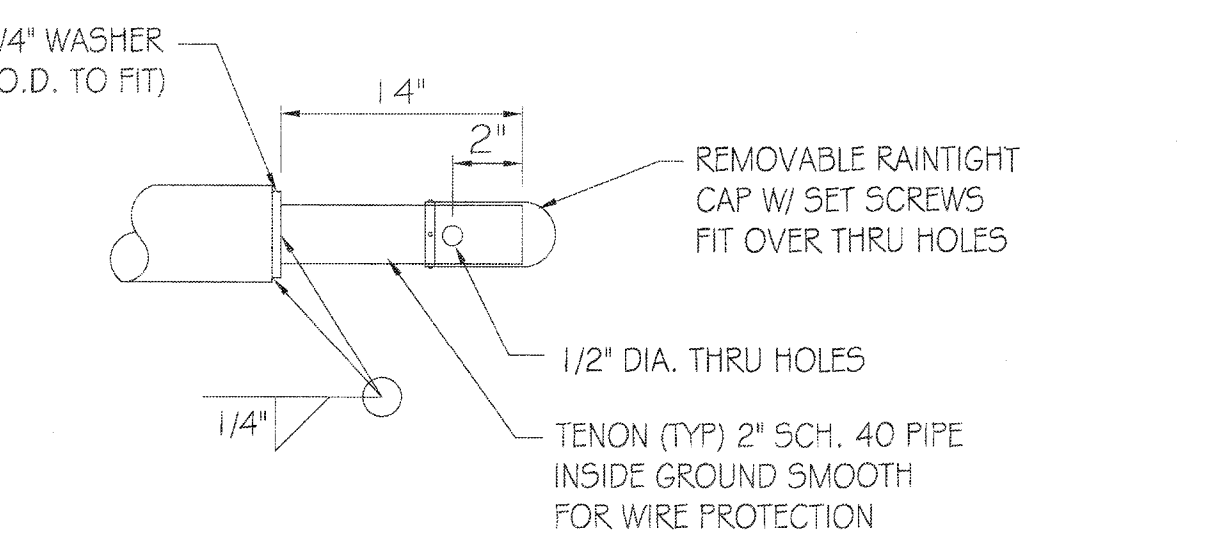
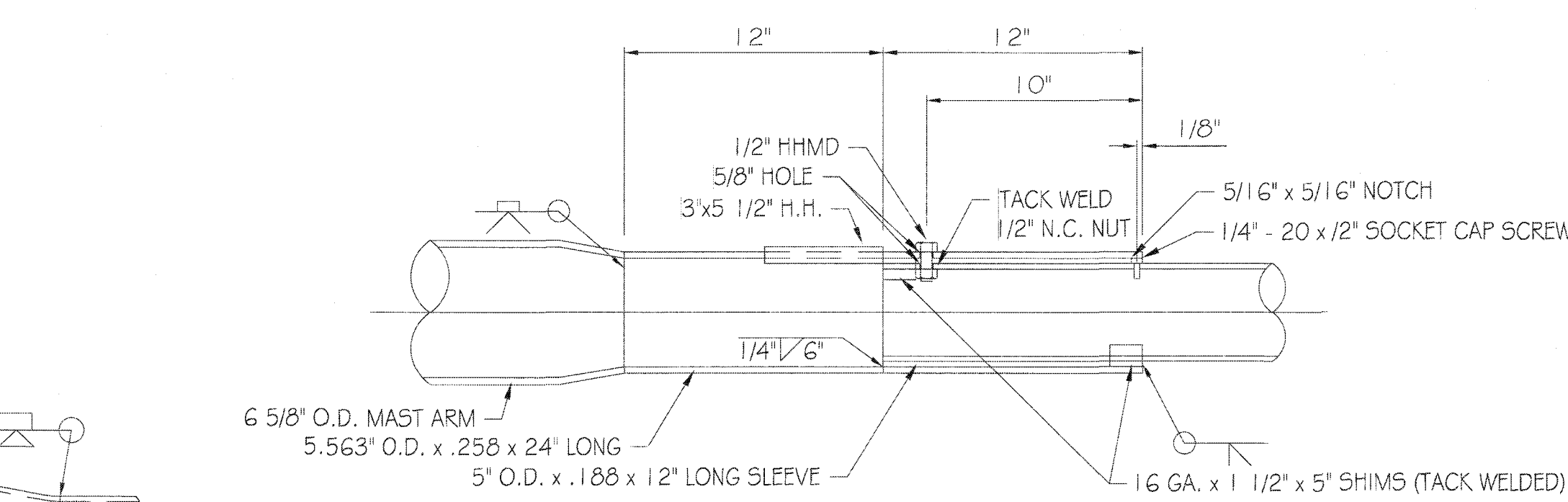
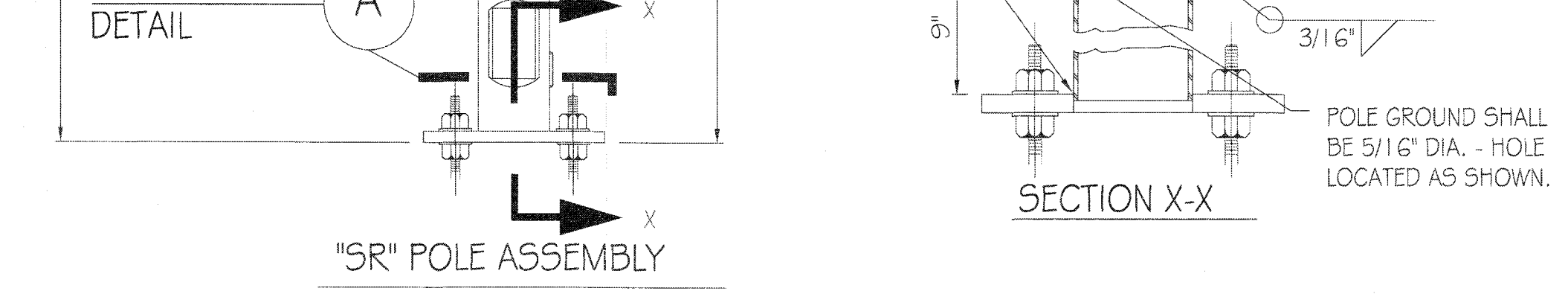
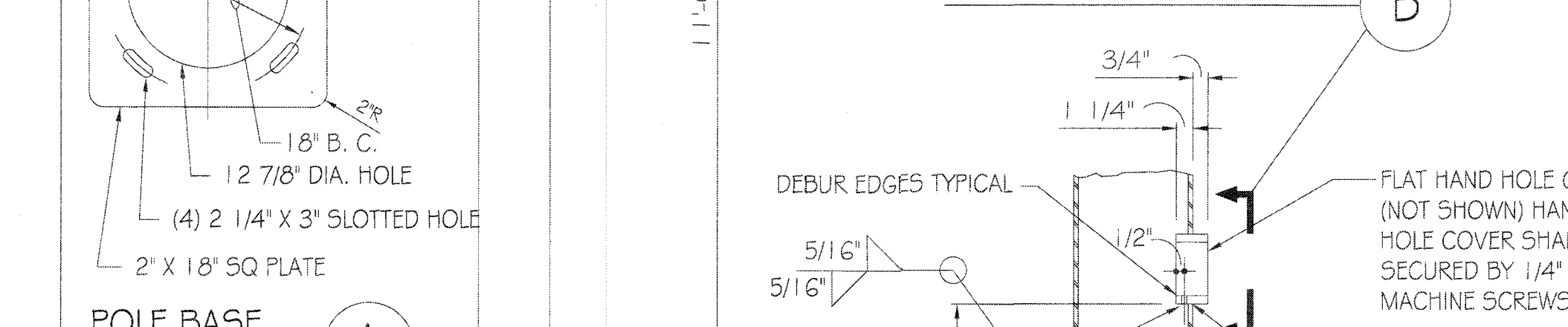
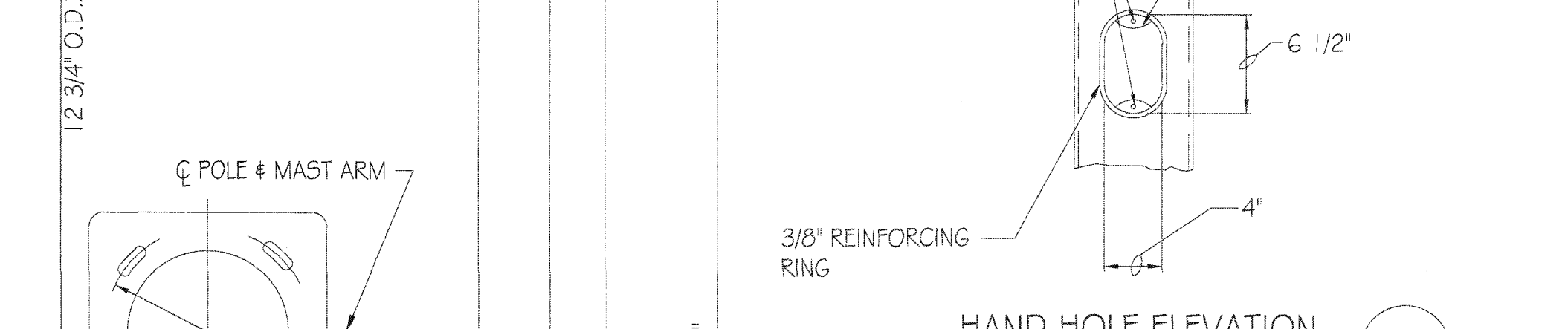
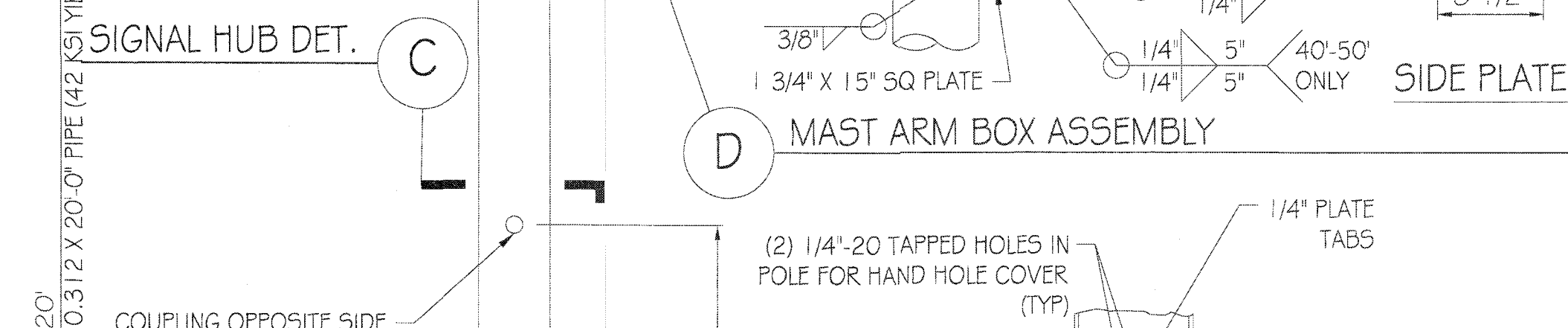
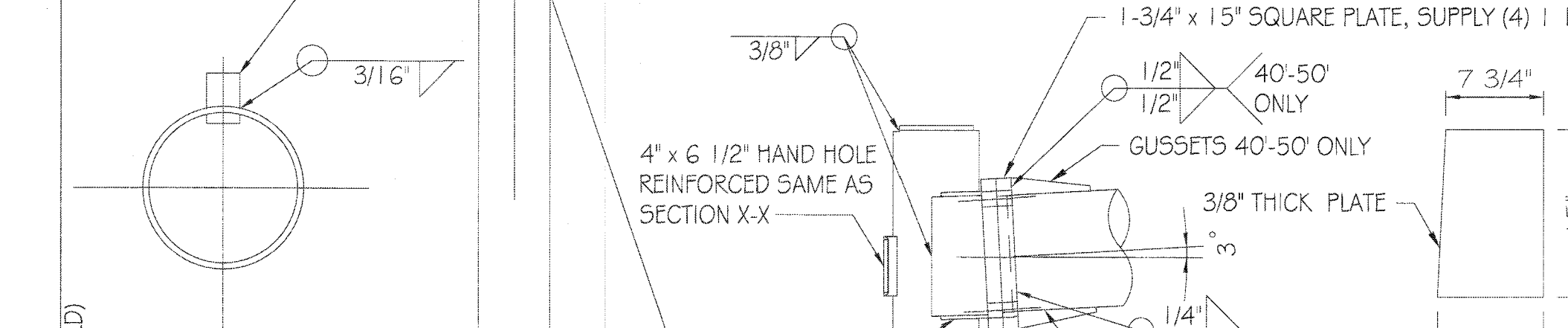
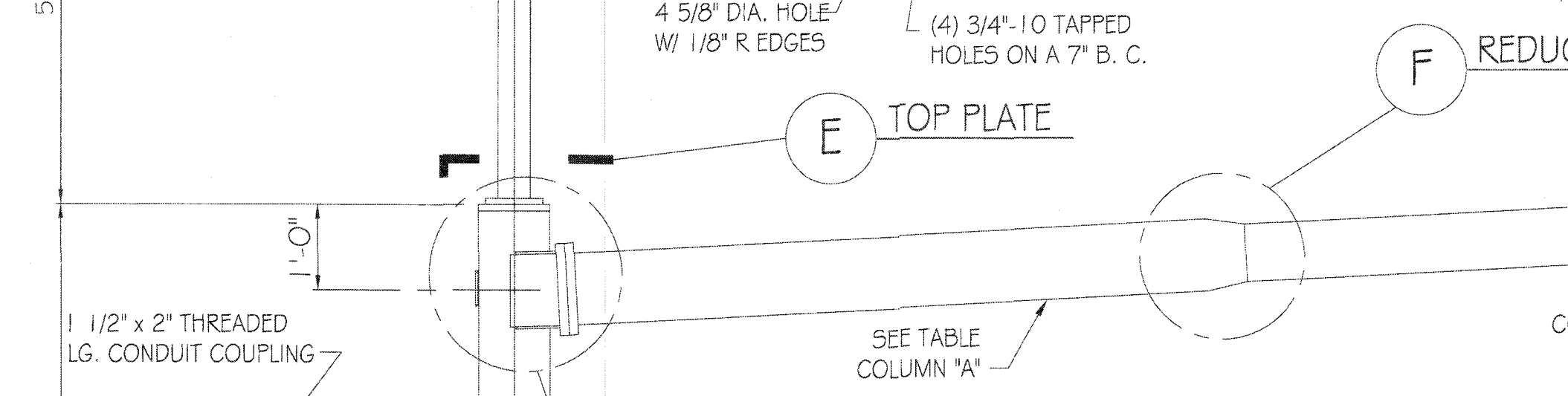
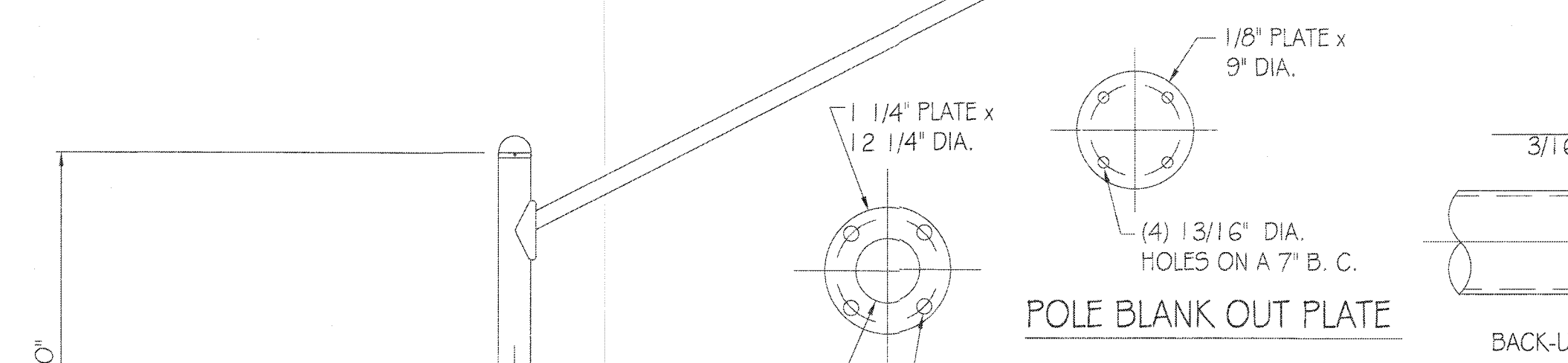
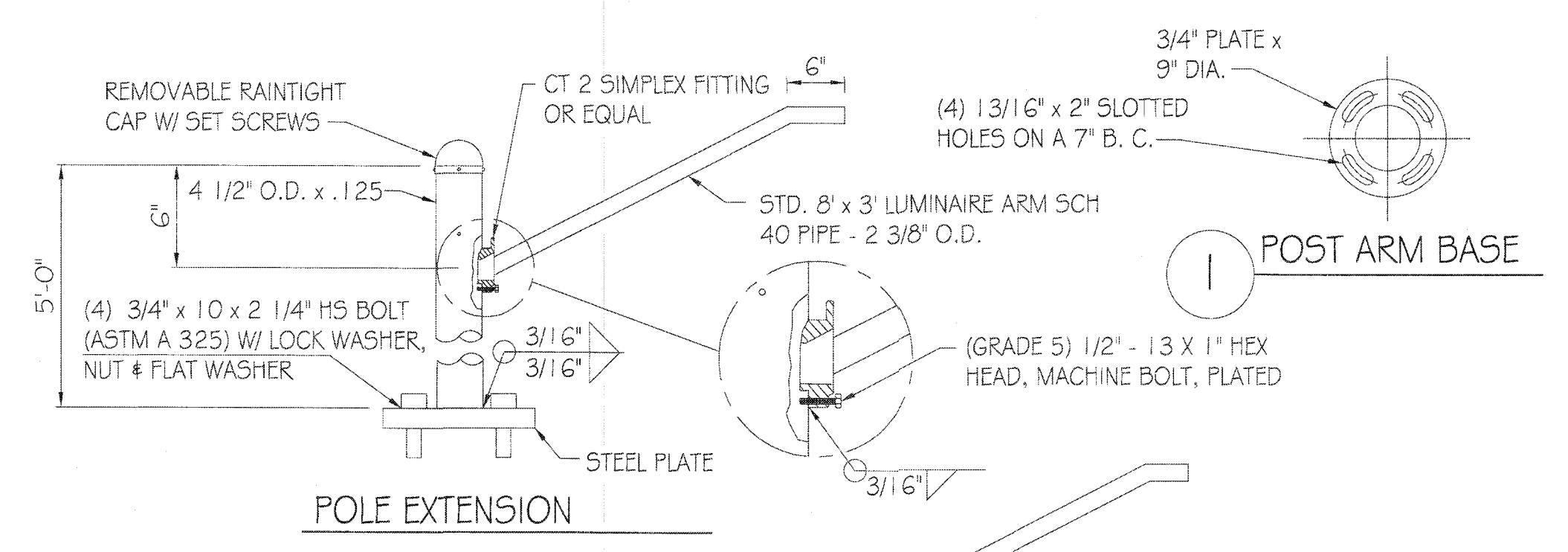

PER CITY OF PHOENIX CITY CODE CHAPTER 2, SECTION 2-26, THESE PLANS ARE FOR OFFICIAL USE ONLY & MAY NOT BE SHARED WITH OTHERS EXCEPT AS REQUIRED TO FULFILL THE OBLIGATIONS OF YOUR CONTRACT WITH THE CITY OF PHOENIX.

CITY OF PHOENIX, ARIZONA
STREET TRANSPORTATION DEPARTMENT
TRAFFIC SIGNAL STANDARD DETAILS

SR POLE
MAST ARMS
AND MAST ARM EXTENSIONS

TRAFFIC SIGNAL DETAILS
CITY OF PHOENIX, ARIZONA
STREET TRANSPORTATION DEPARTMENT

REVISION #	DATE	REVISION	DRAWN BY	APPROVED BY
1	5/8/2017	Added note #8	ZR	[Signature]

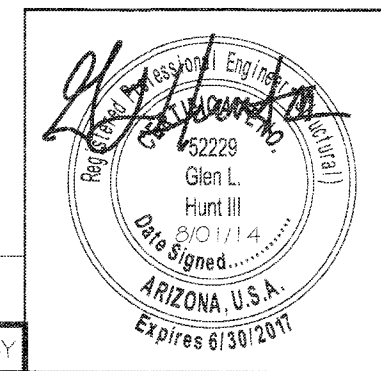

TPP File Number: J0164
TS 1-2
5-8-2017

PROJECT #:	DR:	DES:	CK:	SHEET NO.:	TOTAL SHEETS:

F.H.W.A. REGION	STATE	PROJ. NO.	NO.	TOTAL
9	ARIZ.			

DR: DES: CK: DATE:

- NOTES:**
- DESIGN IN ACCORDANCE WITH AASHTO 'STANDARD SPECIFICATIONS FOR STRUCTURAL SUPPORTS FOR HIGHWAY SIGNS, LUMINAIRES, AND TRAFFIC SIGNALS', 5TH EDITION, 2009.
 - PIPE SHALL HAVE MINIMUM YIELD STRENGTH SPECIFIED.
 - ALL OTHER STEEL SHALL HAVE A MINIMUM YIELD STRENGTH OF 36 KSI.
 - WELDING SHALL BE WITH E-70 LOW HYDROGEN RODS AND SHALL CONFORM TO AWS D 1.1 LATEST EDITION.
 - POLE AND ARM SHALL BE POWDER COATED PER CITY SPECIFICATIONS.
 - INCLUDE ALL HANDHOLE COVERS W/ 2 EA. 1/4"-20 SS MACHINE SCREWS.
 - 'SM' POLE CAN ONLY SUPPORT UP TO A 35' MAST ARM.
 - ALL EQUIPMENT SHALL BE PERMANENTLY LABELED WITH MANUFACTURERS NAME, MONTH, DAY, YEAR MANUFACTURED AND EQUIPMENT TYPE.

MAST ARM STAGE PIPE DIAMETER

PRIMARY MAST ARM LENGTH	COLUMN A	COLUMN B
15'	6 5/8" O.D. X 0.188 X 6'-4" (42 KSI)	6 5/8" O.D. X 0.156 X 6'-0" (42 KSI)
25'	6 5/8" O.D. X 0.188 X 13'-4" (56 KSI)	6 5/8" O.D. X 0.156 X 8'-8" (56 KSI)

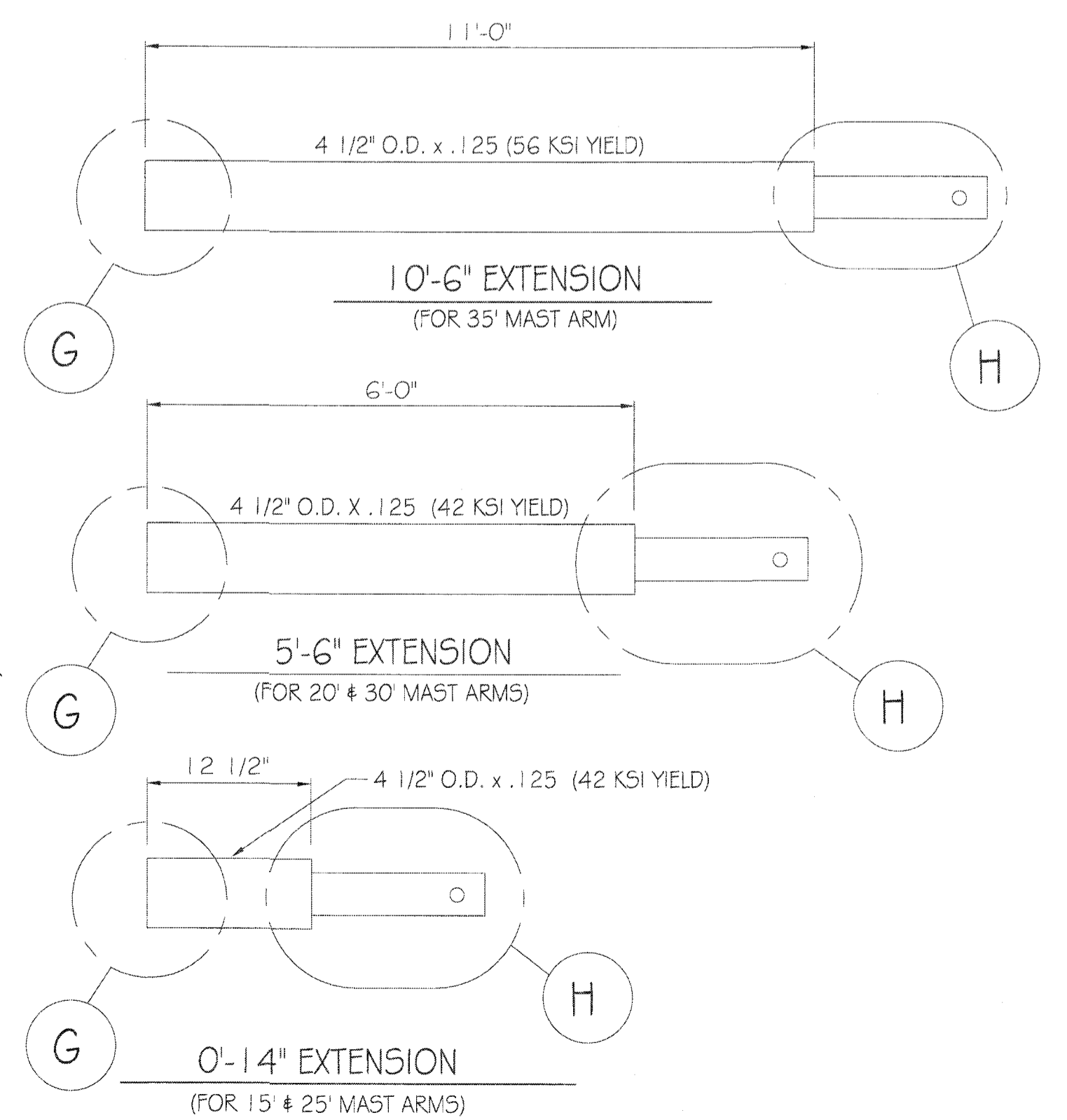
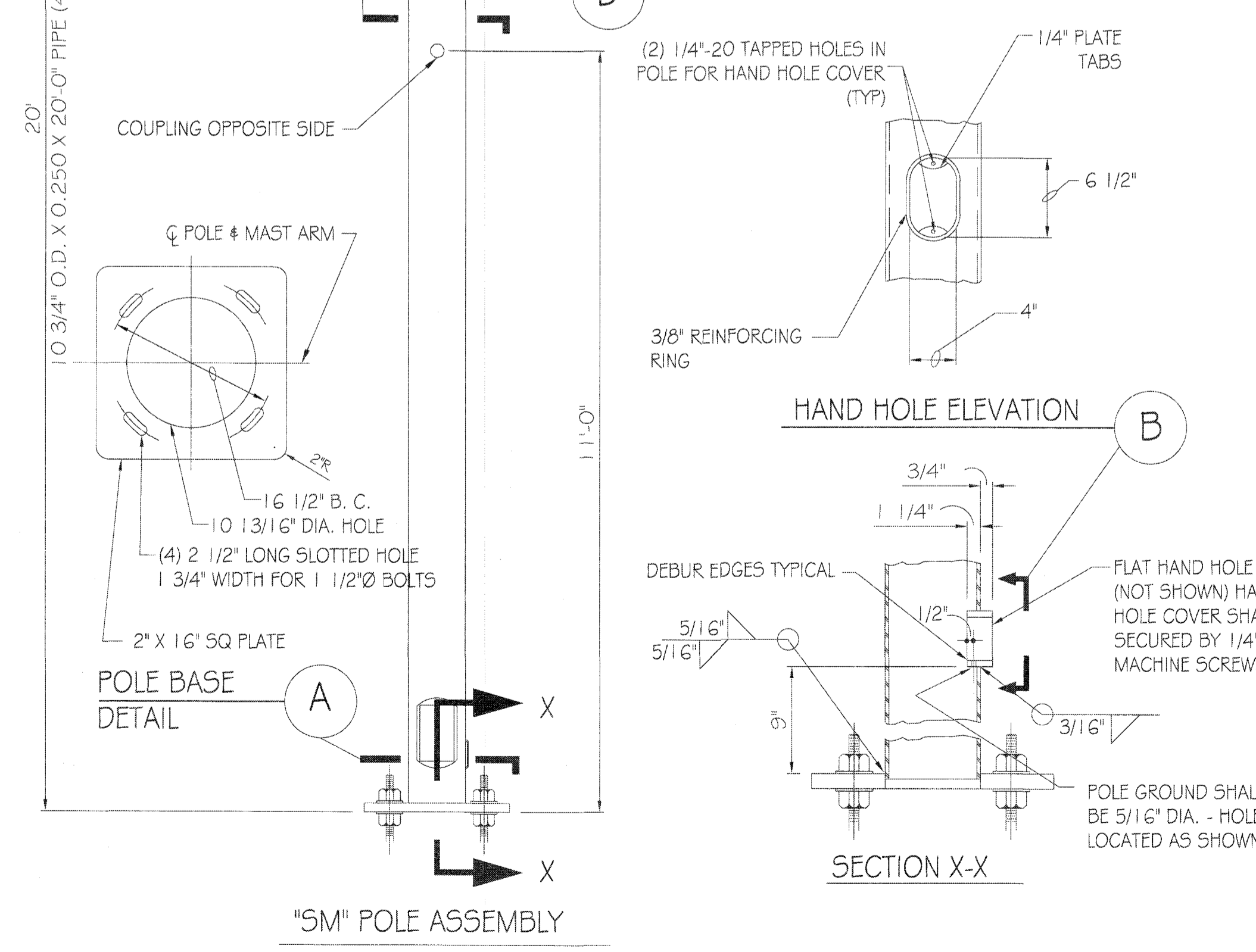
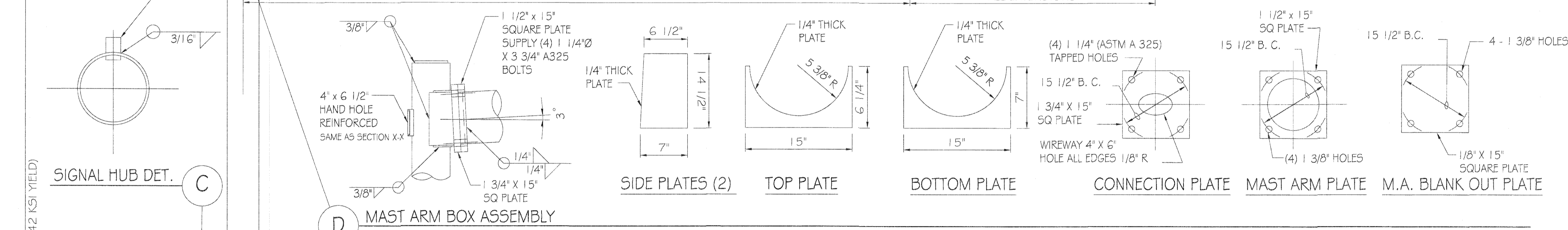
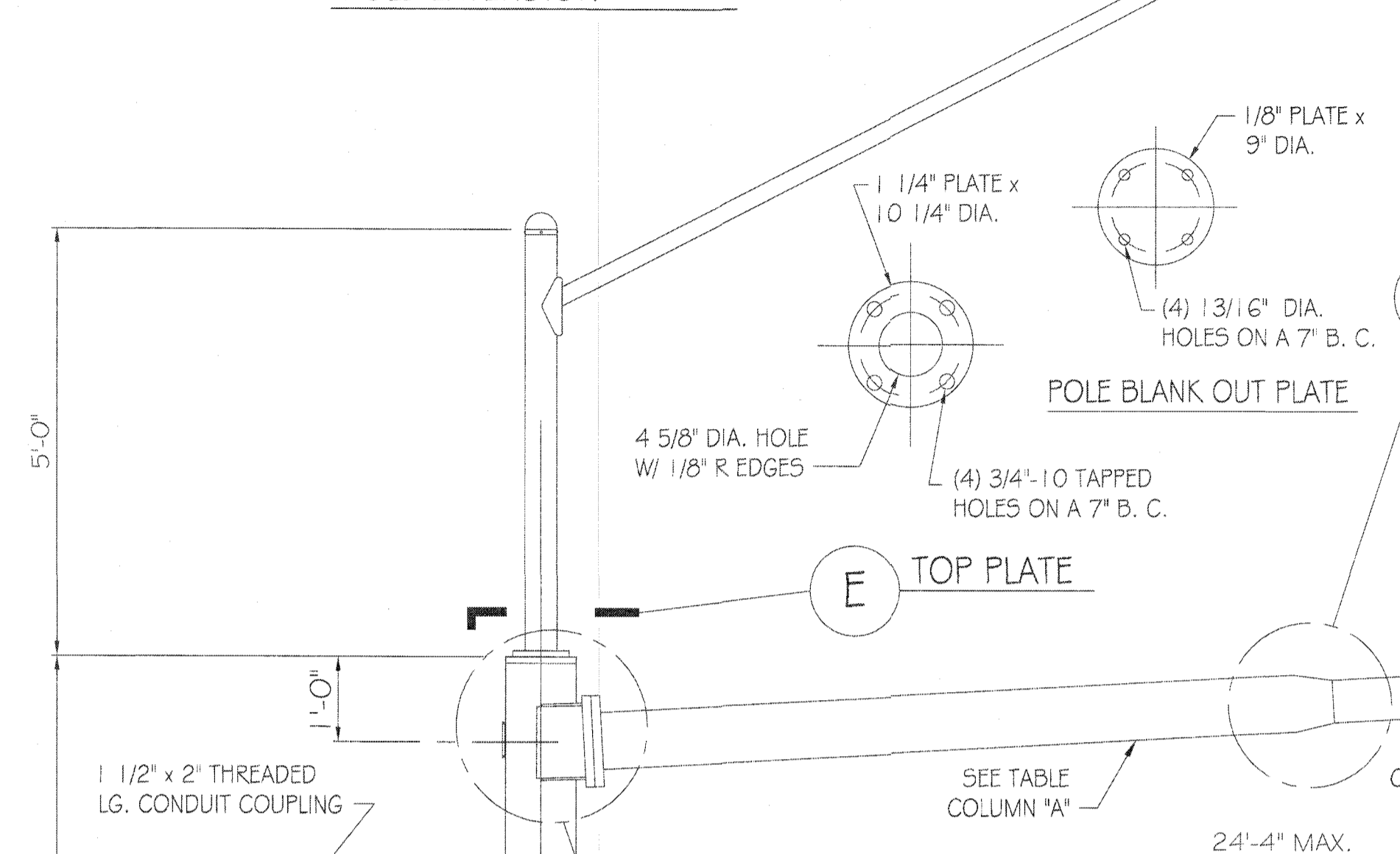
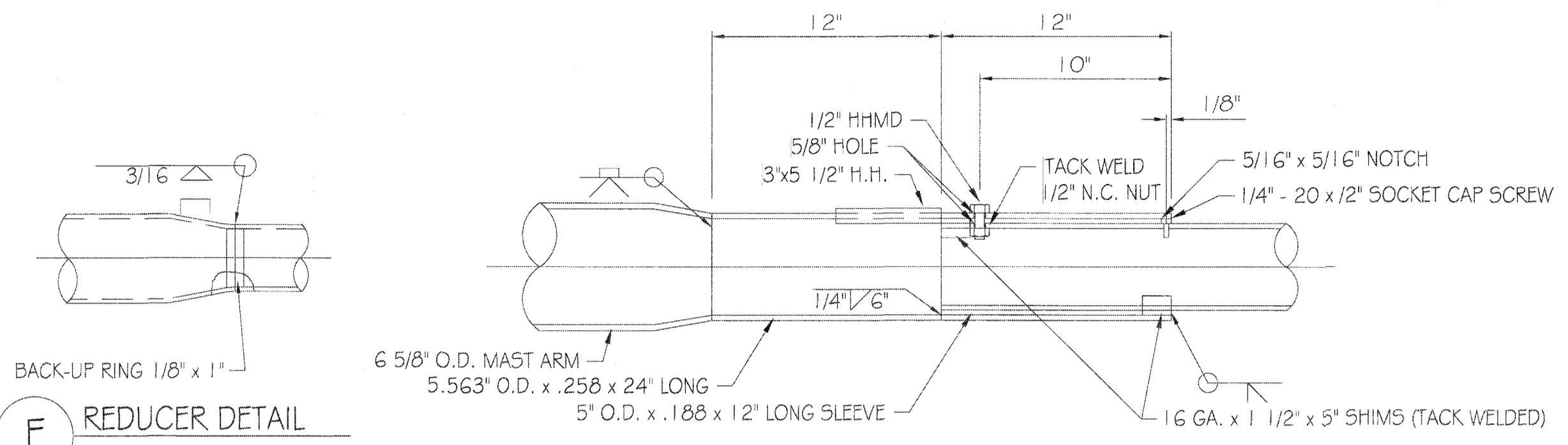
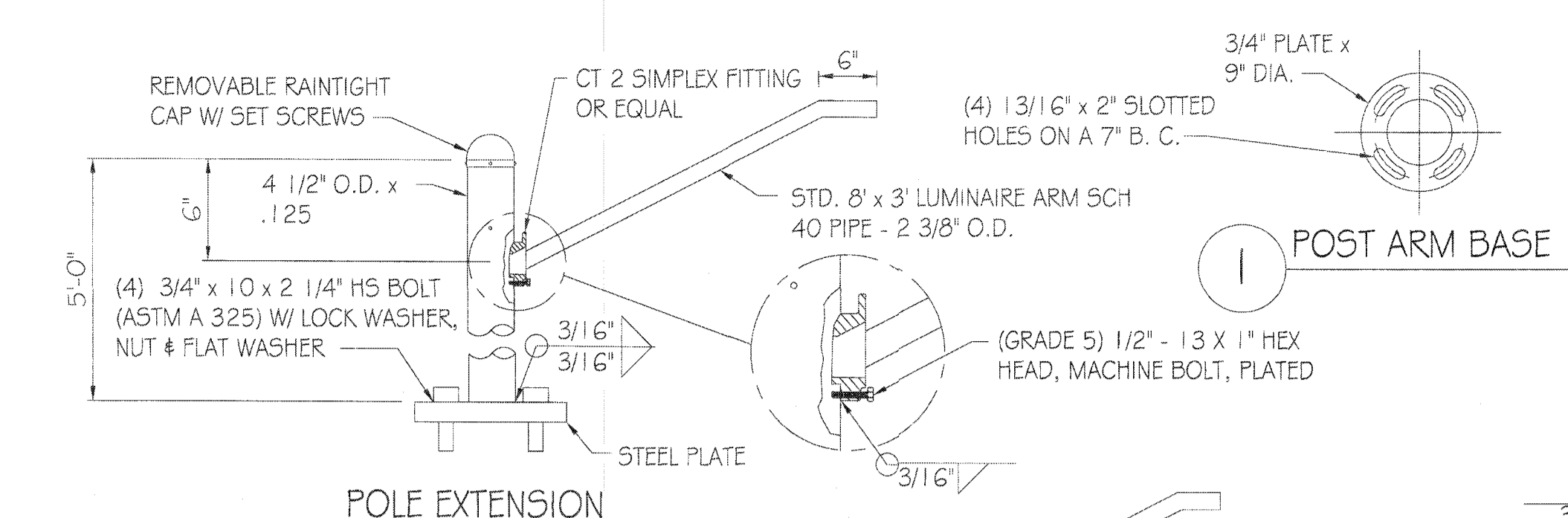

CITY OF PHOENIX, ARIZONA
STREET TRANSPORTATION DEPARTMENT
TRAFFIC SIGNAL STANDARD DETAILS

SM POLE
MAST ARMS
AND MAST ARM EXTENSIONS

TRAFFIC SIGNAL DETAILS
CITY OF PHOENIX, ARIZONA
STREET TRANSPORTATION DEPARTMENT

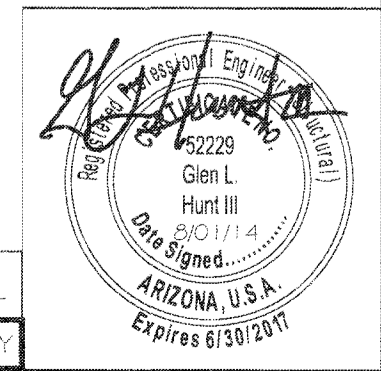

REVISION #	DATE	REVISION	DRAWN BY	APPROVED BY
1	5/8/2017	Added note #5	ZR	[Signature]

TPP File Number	TS 1-3	PROJECT #:	SHEET NO.	TOTAL SHEETS
10164	5-8-2017			

F.H.W.A. REGION	STATE	PROJ. NO.	NO.	TOTAL
9	ARIZ.			

DR: DES: CK: DATE:

- NOTES:**
- DESIGN IN ACCORDANCE WITH AASHTO 'STANDARD SPECIFICATIONS FOR STRUCTURAL SUPPORTS FOR HIGHWAY SIGNS, LUMINAIRES, AND TRAFFIC SIGNALS', 5TH EDITION, 2009.
 - MATERIALS - ALL NEW PIPE - ASTM A 53 GR B PLATES - ASTM A 36 ANCHOR BOLTS - ASTM A 36
 - WELDING ALL WELDING SHALL USE E-70 ELECTRODES AND SHALL CONFORM TO ANSI/A.W.S. D 1.1.
 - POLE AND ARM SHALL BE POWDER COATED PER CITY SPECIFICATIONS.
 - TOP MOUNTED CAMERA DIMENSIONS: 5' X 5' X 25'
 - ALL EQUIPMENT SHALL BE PERMANENTLY LABELED WITH MANUFACTURERS NAME, MONTH, DAY, YEAR MANUFACTURED AND EQUIPMENT TYPE.

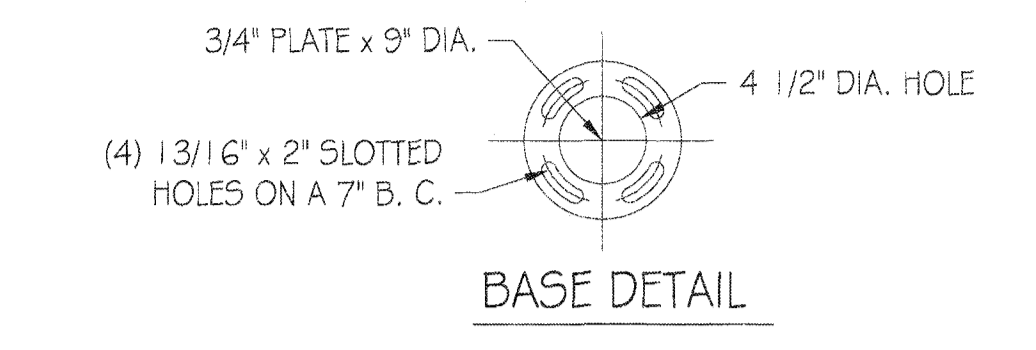
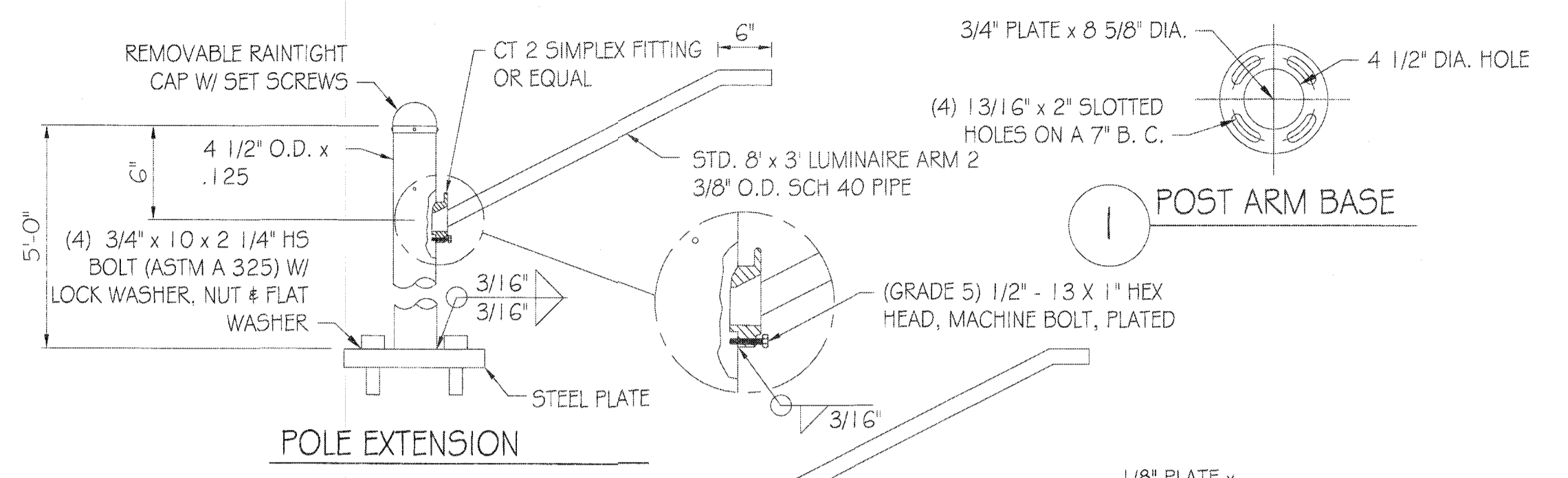

MATERIALS - 20' POLE EXTENSION
PIPE - 56 KSI MINIMUM YIELD STRENGTH
ALL OTHER STEEL - 50 KSI MINIMUM YIELD STRENGTH

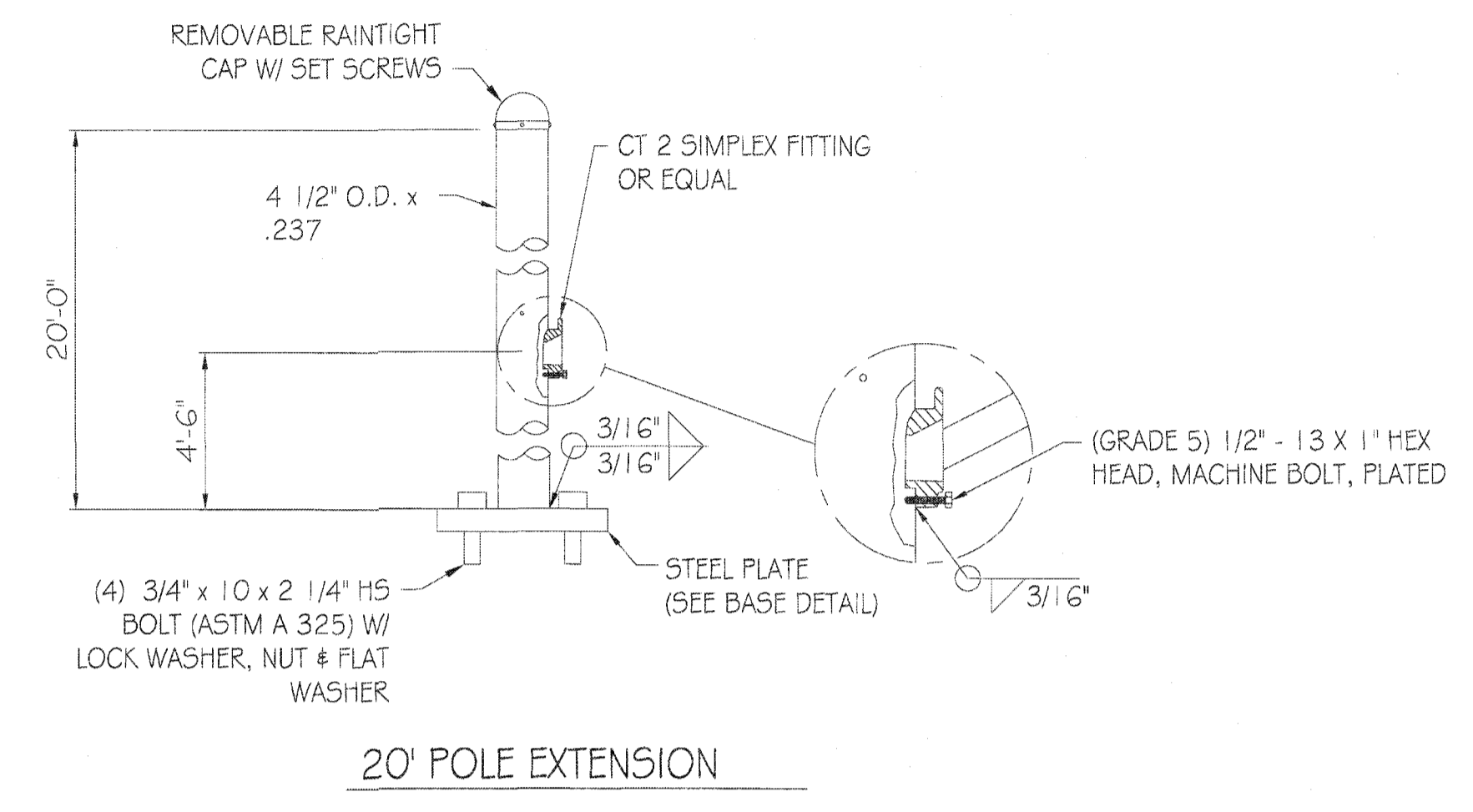

MATERIALS - 10' POLE EXTENSION
PIPE - 56 KSI MINIMUM YIELD STRENGTH
ALL OTHER STEEL - 36 KSI MINIMUM YIELD STRENGTH

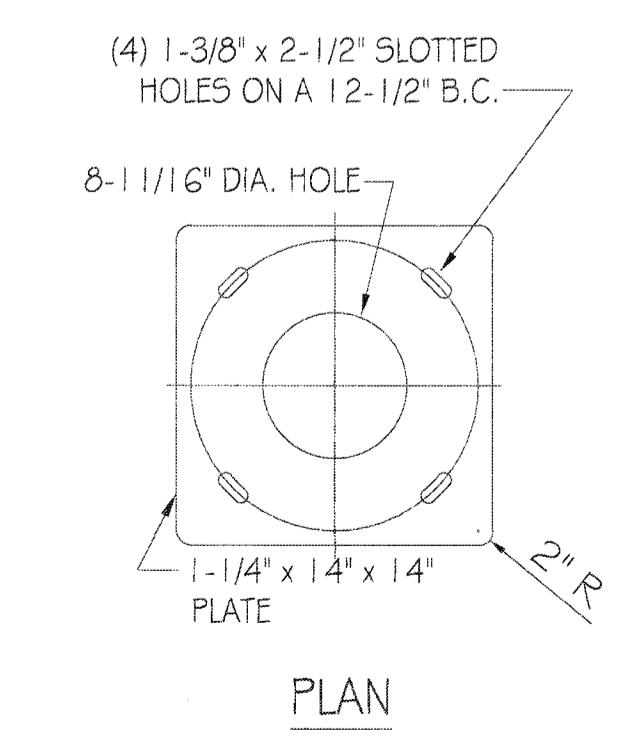
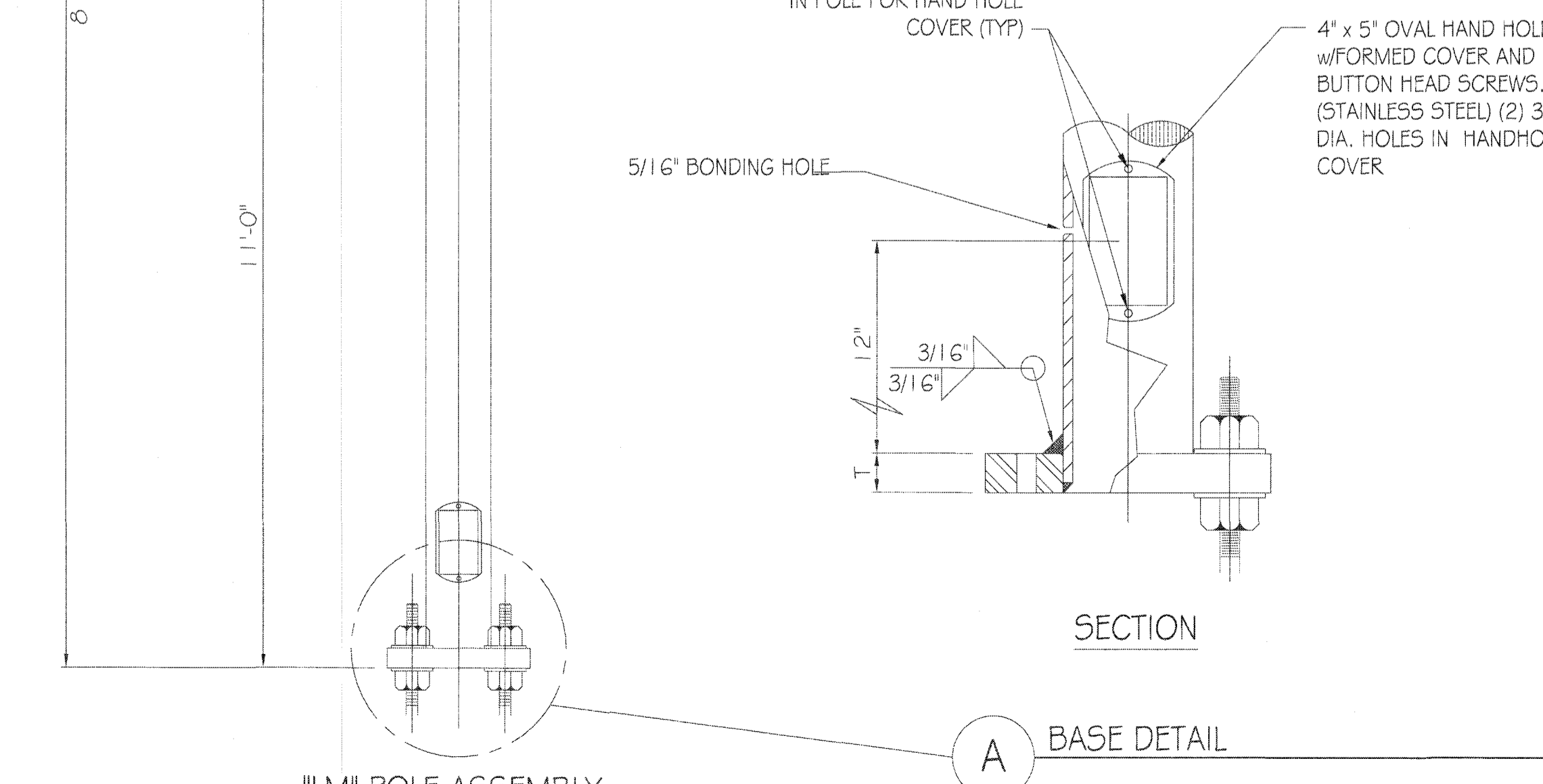
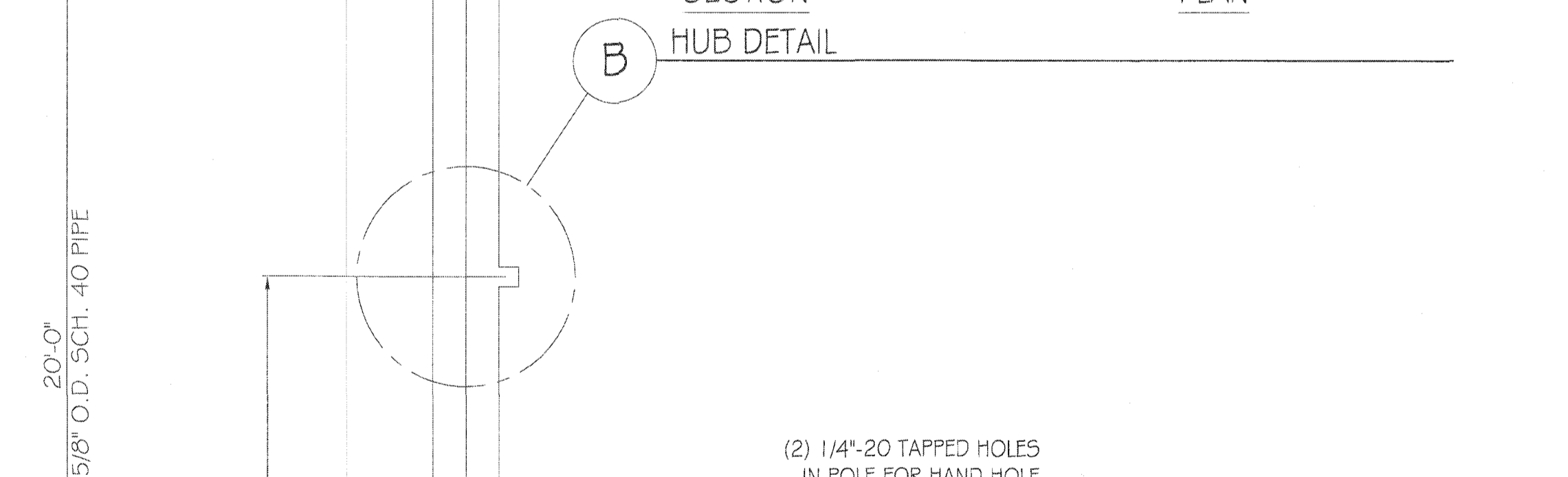
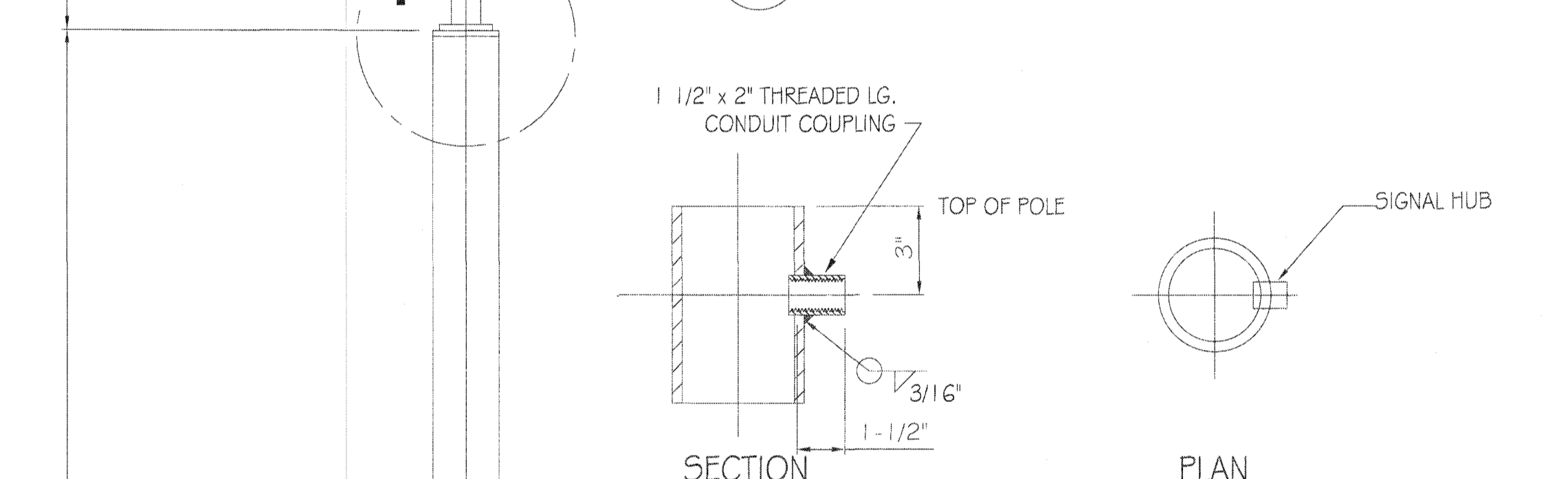
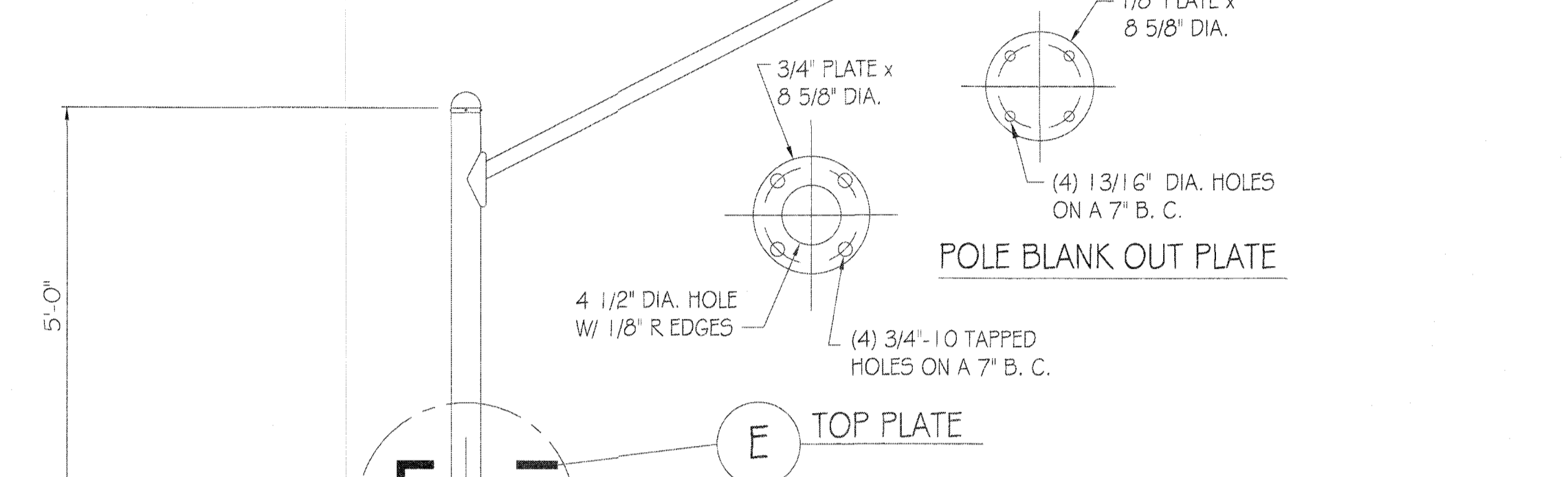
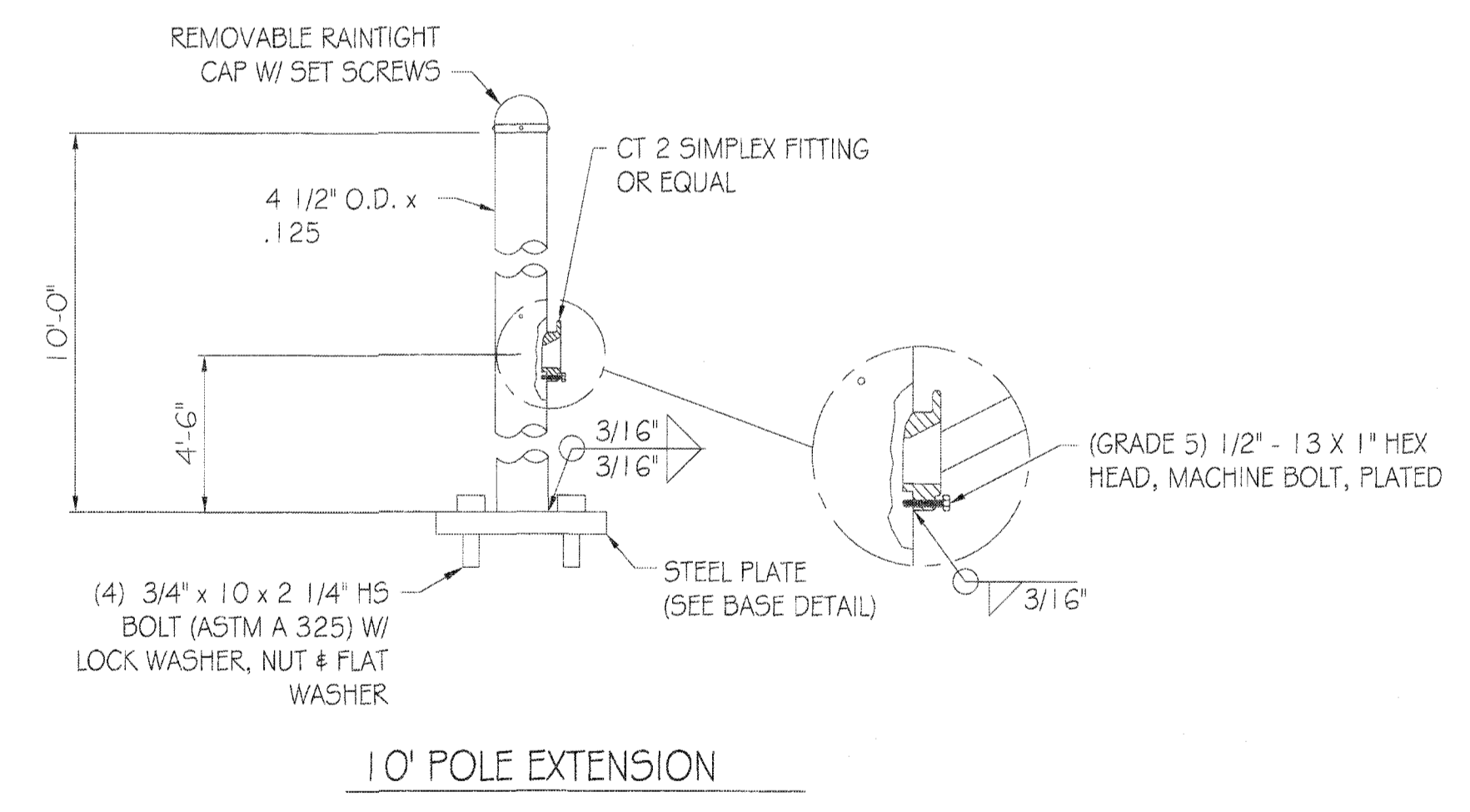
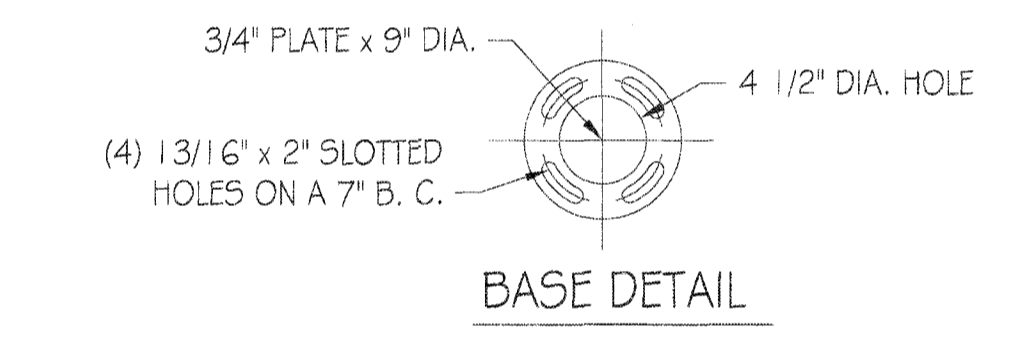

CITY OF PHOENIX, ARIZONA
STREET TRANSPORTATION DEPARTMENT
TRAFFIC SIGNAL STANDARD DETAILS

TRAFFIC SIGNAL DETAILS
CITY OF PHOENIX, ARIZONA
STREET TRANSPORTATION DEPARTMENT

LM POLE AND RISERS

TPP File Number: 10164 TS 1-4
DATE: 5-8-2017

PROJECT #:	DR:	DES:	CK:	SHEET NO:	TOTAL SHEETS:

REVISION #	DATE	REVISION	DRAWN BY	APPROVED BY
1	5/8/2017	Added note #6	ZR	[Signature]

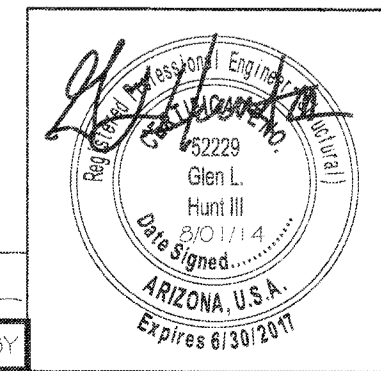

PER CITY OF PHOENIX CITY CODE CHAPTER 2, SECTION 2-26, THESE PLANS ARE FOR OFFICIAL USE ONLY & MAY NOT BE SHARED WITH OTHERS EXCEPT AS REQUIRED TO FULFILL THE OBLIGATIONS OF YOUR CONTRACT WITH THE CITY OF PHOENIX.

NOTE(S):

1. ALL WIRE ENTRANCE AND EXIT HOLES SHALL BE FREE OF ALL BURRS AND SHARP EDGES.
2. SOME HIDDEN LINES NOT SHOWN FOR CLARITY.
3. DO NOT SCALE TO DRAWING.
4. STAMP / TAG WITH YEAR MANUFACTURED, MANUFACTURER LOGO AND "G-POLE".
5. PIPE MATERIAL: ASTM A500 GR B (Fy 42 KSI).
6. USES CITY OF PHOENIX TYPE "LM" FOUNDATION.

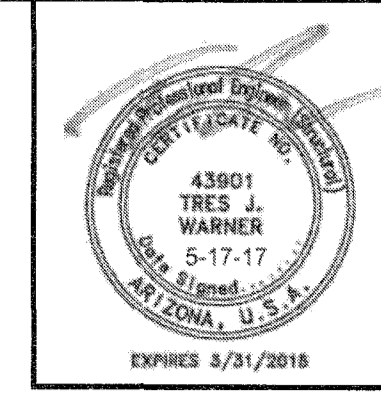

F.H.W.A. REGION	STATE	PROJ. NO.	NO.	TOTAL
9	ARIZ.			
DR:	DES:	CK:	DATE:	

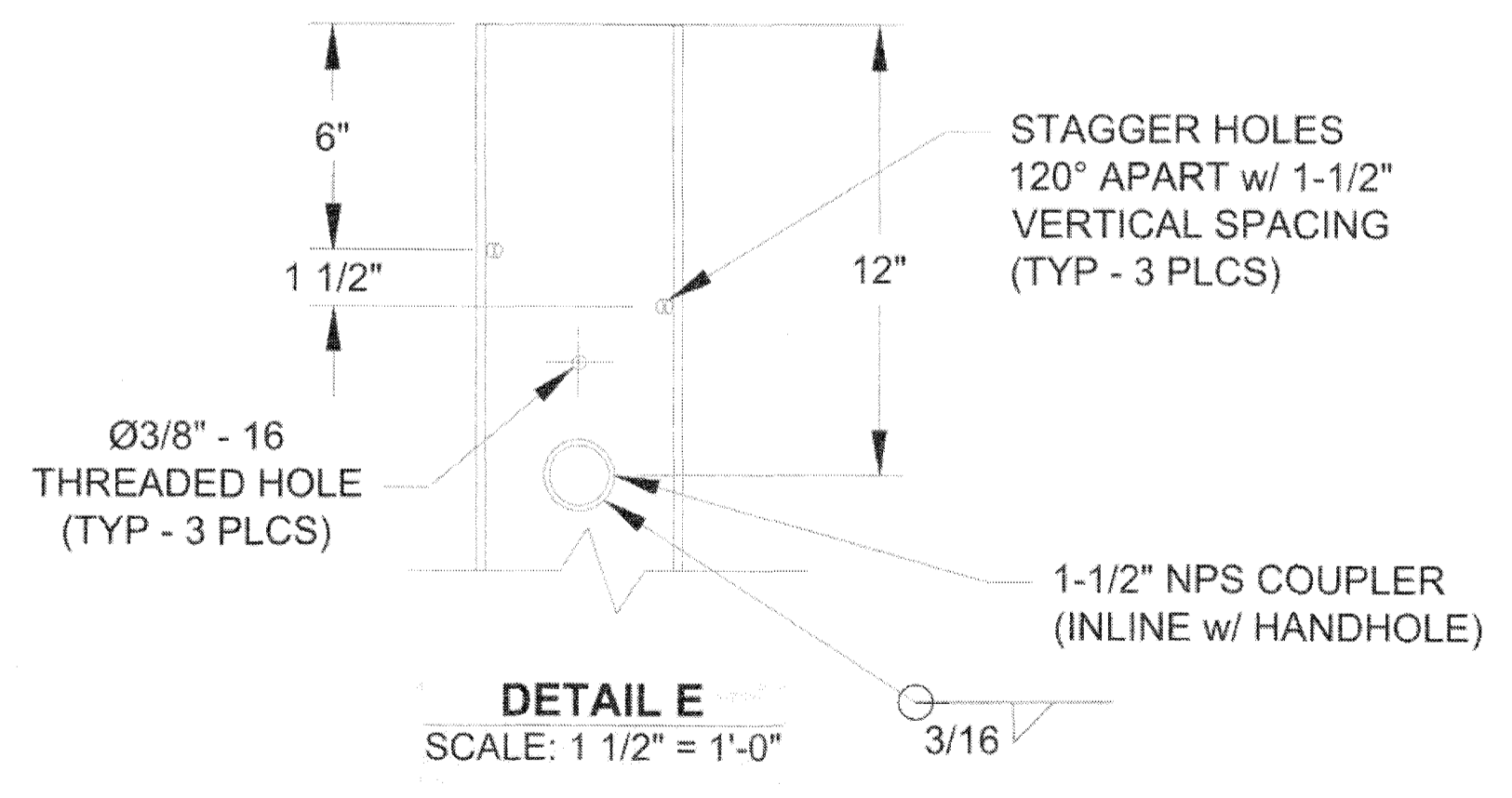
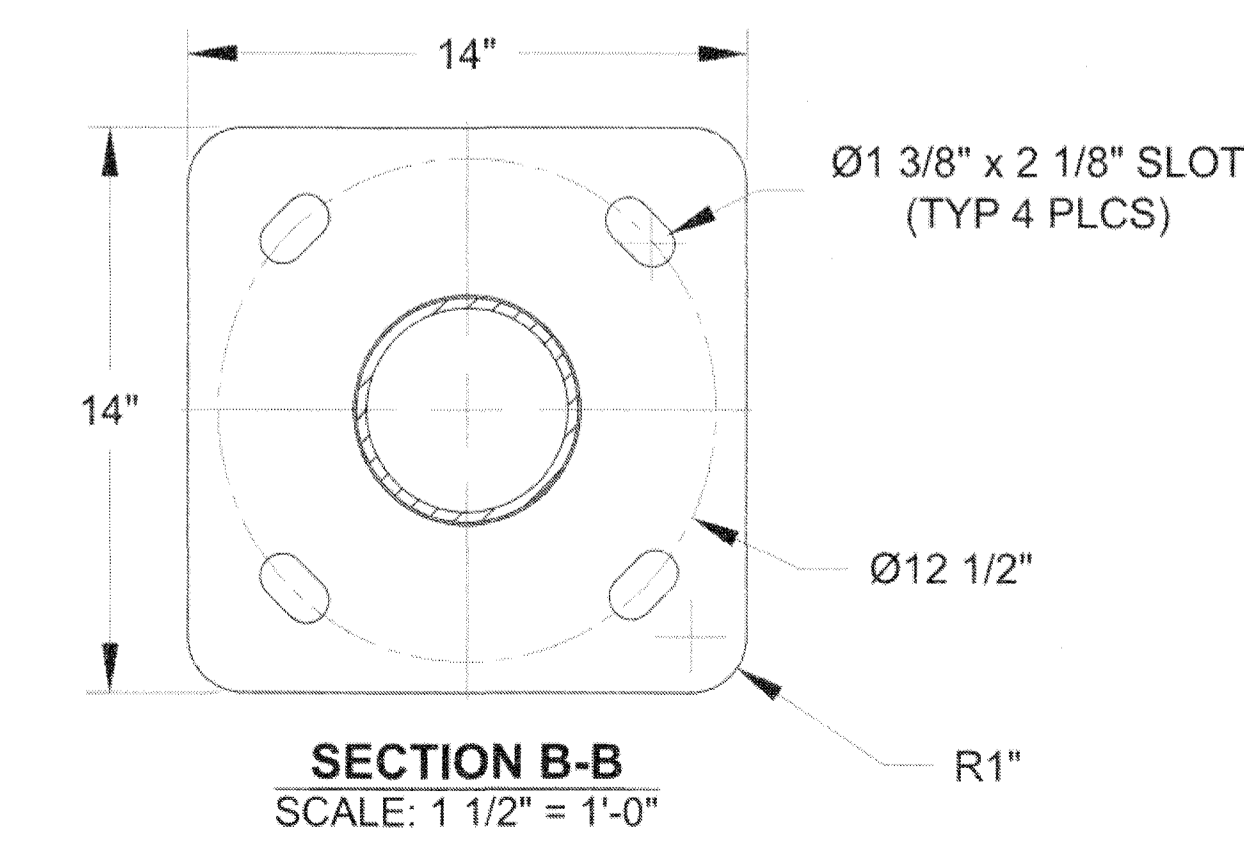
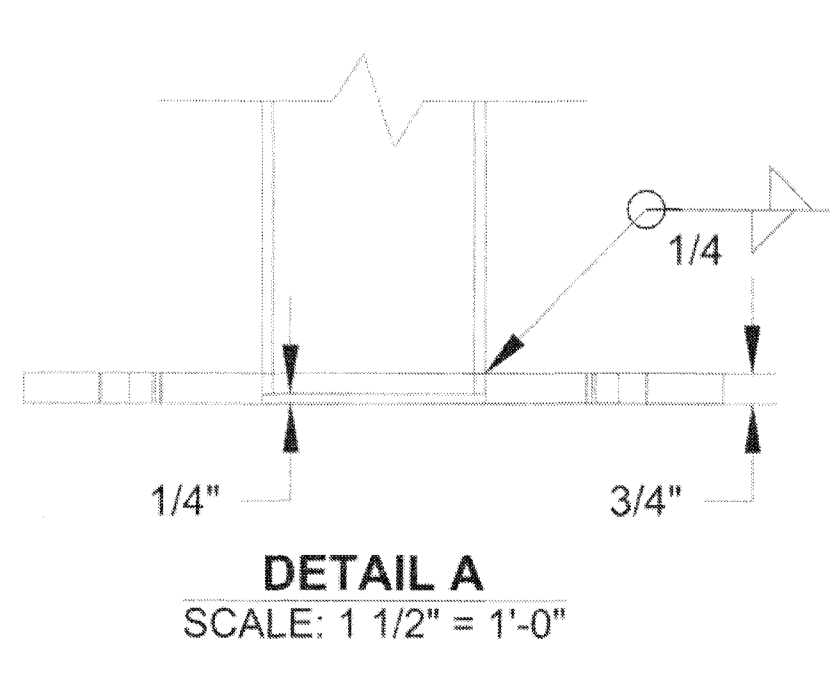
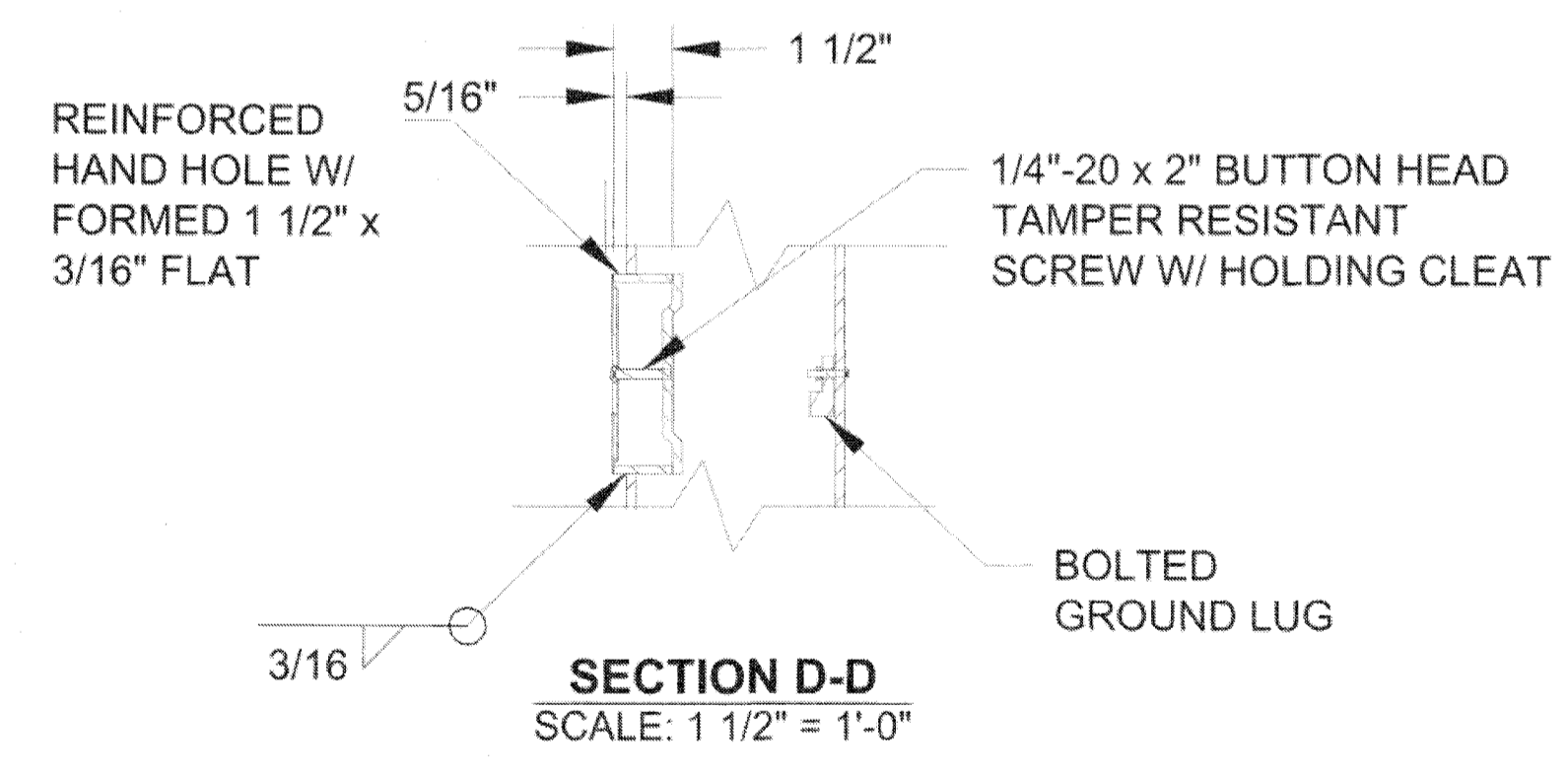
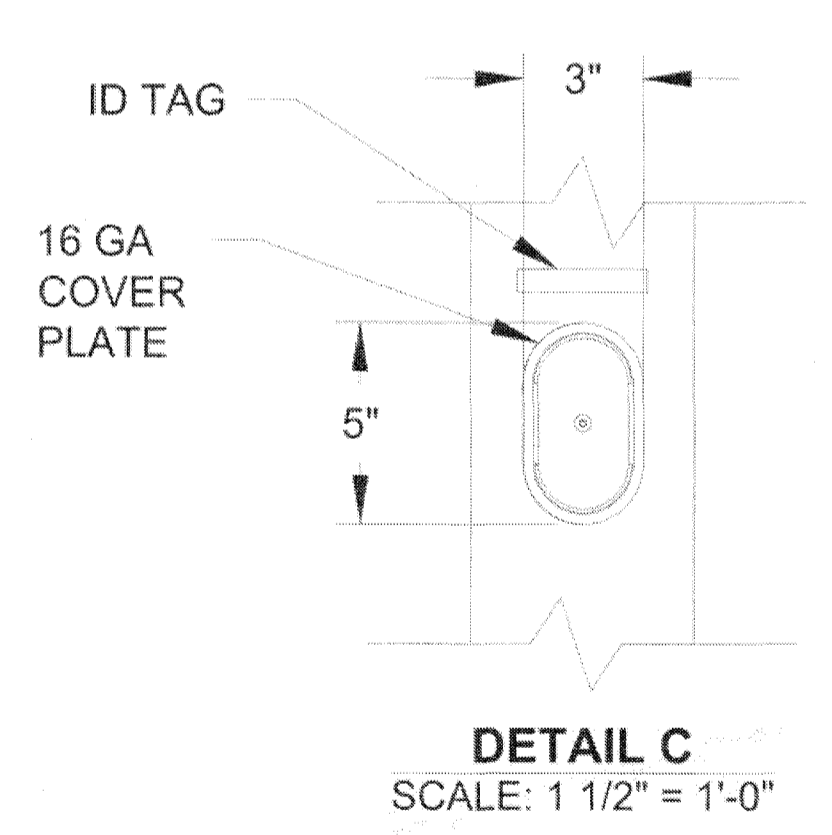
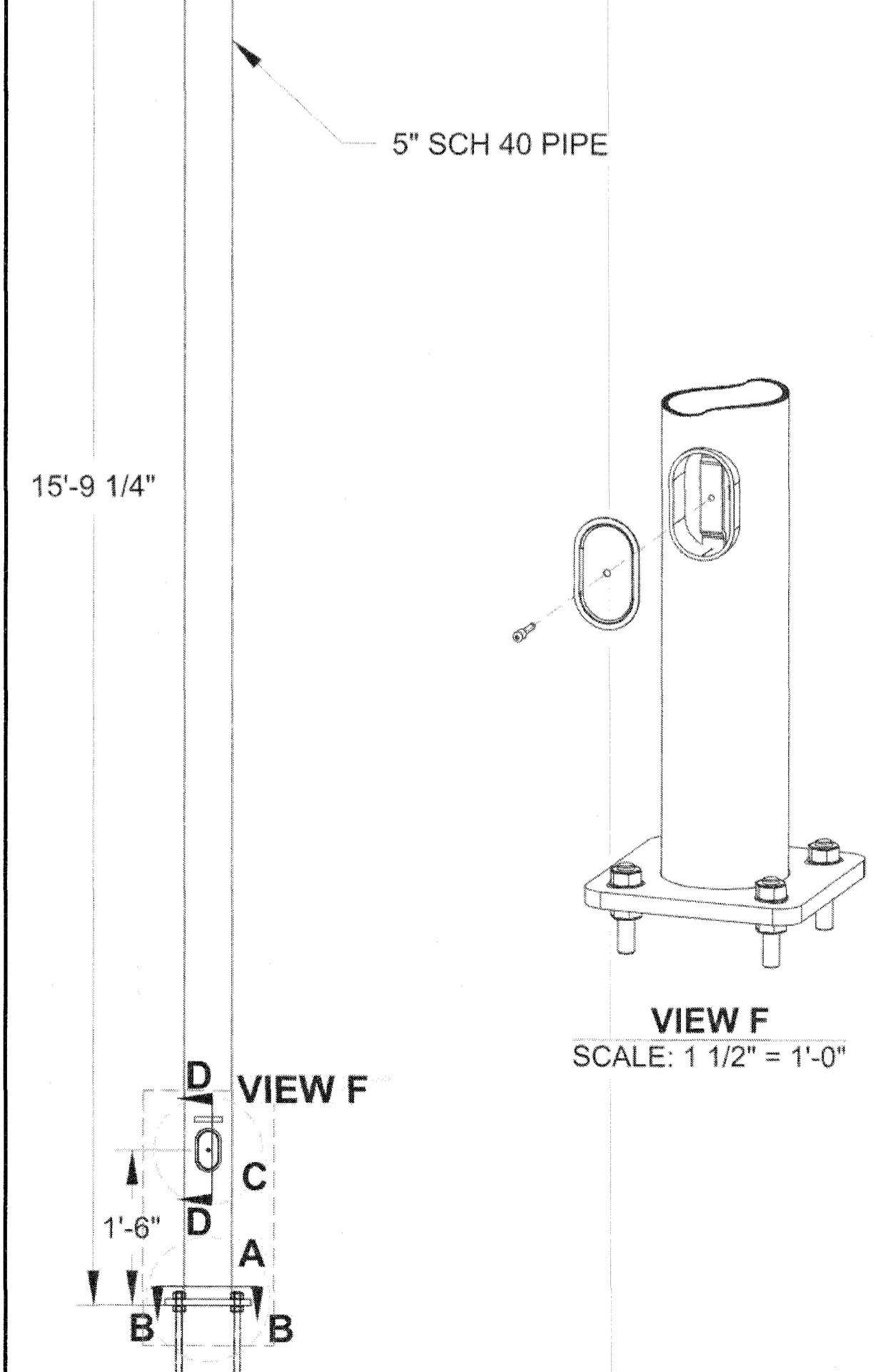
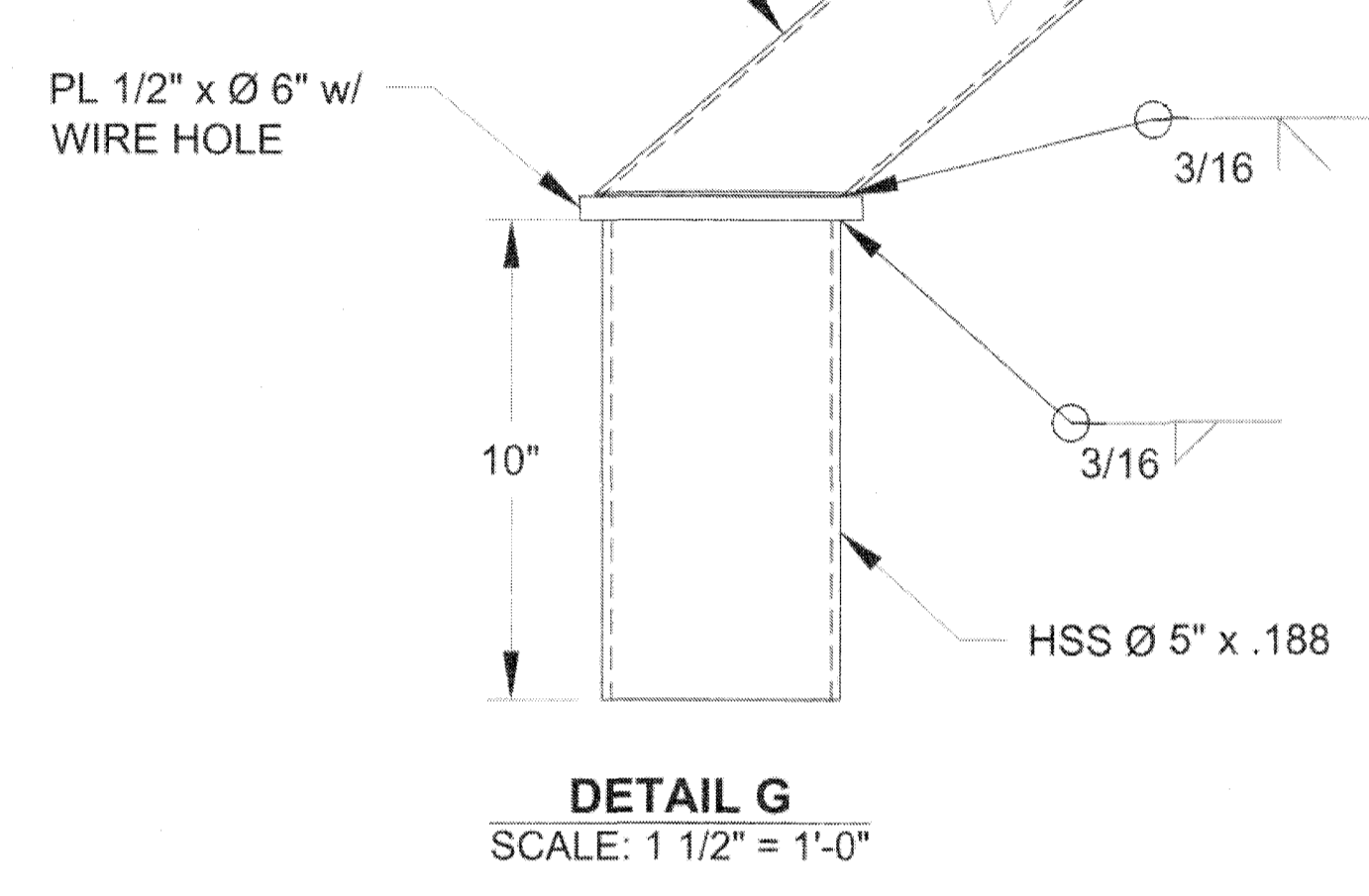
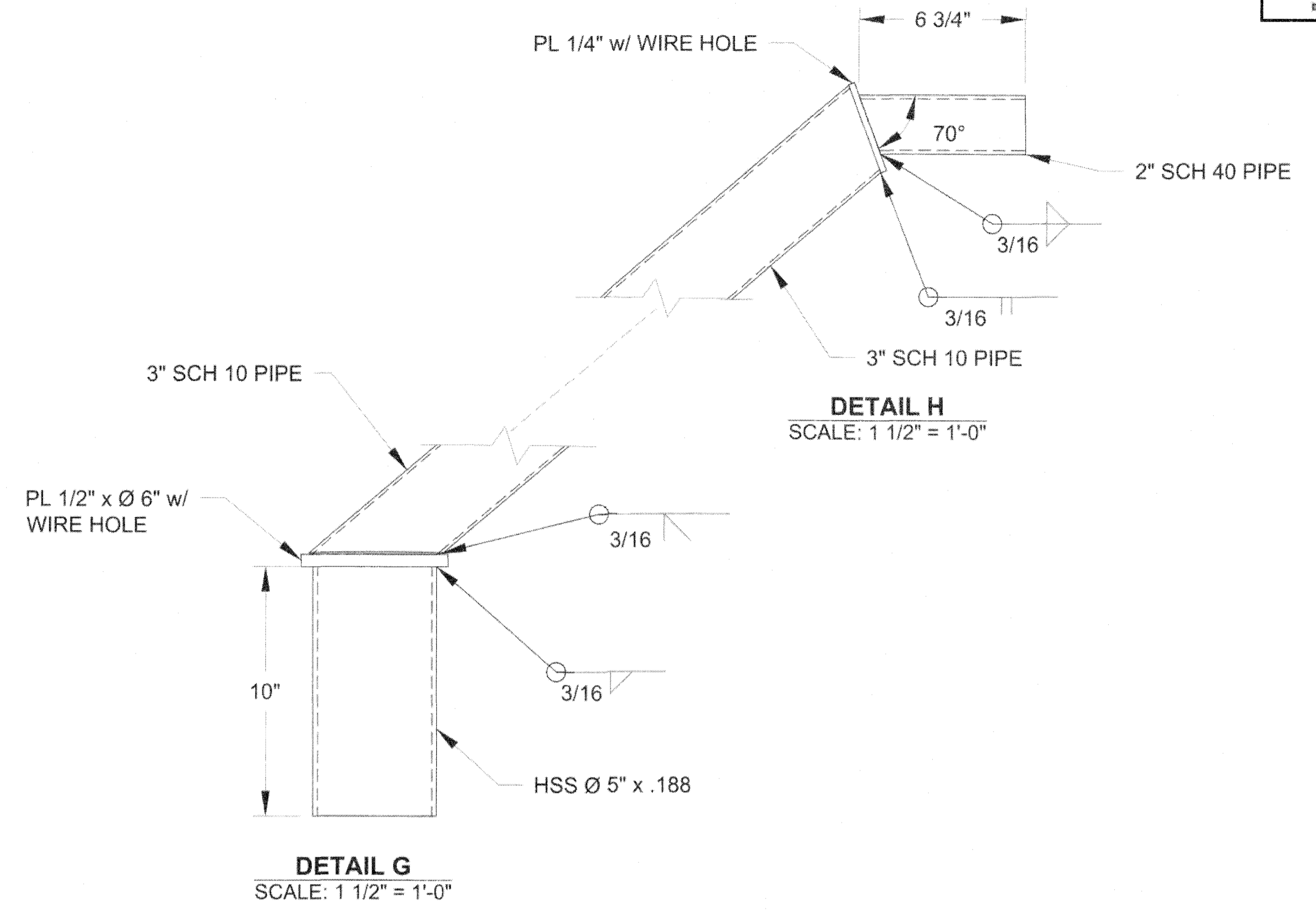
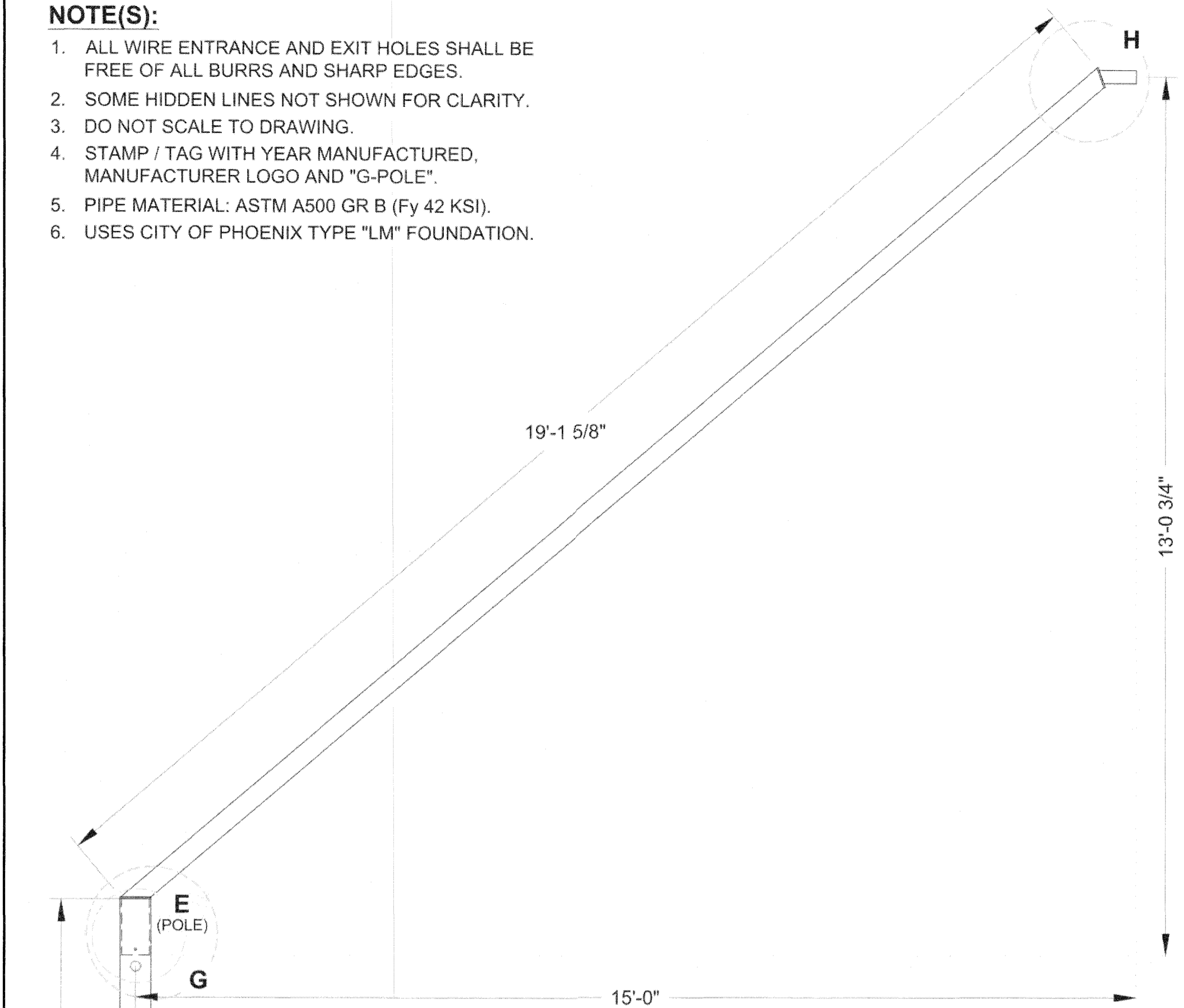

"PER CITY OF PHOENIX CITY CODE CHAPTER 2, SECTION 2-28, THESE PLANS ARE FOR OFFICIAL USE ONLY & MAY NOT BE SHARED WITH OTHERS EXCEPT AS REQUIRED TO FULFILL THE OBLIGATIONS OF YOUR CONTRACT WITH THE CITY OF PHOENIX."

CITY OF PHOENIX, ARIZONA STREET TRANSPORTATION DEPARTMENT TRAFFIC SIGNAL STANDARD DETAILS	
G POLE AND MAST ARMS	
TPP File Number 10164	TS 1-5
DATE: 12-12-2017	DATE:
TRAFFIC SERVICES ENGINEER: <i>Thomas E. Weller</i>	SCALE:

TRAFFIC SIGNAL DETAILS	
CITY OF PHOENIX, ARIZONA STREET TRANSPORTATION DEPARTMENT	
PROJECT #:	
DR:	DES:
DATE:	DATE:
CK:	DATE:
SHEET NO:	TOTAL SHEETS
SCALE:	QS. #:

PROJECT #:

PROJECT #:

F.H.W.A. REGION	STATE	PROJ. NO.	NO.	TOTAL
9	ARIZ.			
DR:	DES:	CK:	DATE:	

NOTES:

- DESIGN IN ACCORDANCE WITH AASHTO "STANDARD SPECIFICATIONS FOR STRUCTURAL SUPPORTS FOR HIGHWAY SIGNS, LUMINAIRES, AND TRAFFIC SIGNALS", 5TH EDITION, 2009.
- PIPE SHALL HAVE MINIMUM YIELD STRENGTH SPECIFIED.
- ALL OTHER STEEL SHALL HAVE A MINIMUM YIELD STRENGTH OF 36 KSI.
- WELDING ALL WELDING SHALL USE E-70 ELECTRODES AND SHALL CONFORM TO ANSI/A.W.S. D1.1.
- POLE AND ARM SHALL BE POWDER COATED PER CITY SPECIFICATIONS.
- ALL EQUIPMENT SHALL BE PERMANENTLY LABELED WITH MANUFACTURERS NAME, MONTH, DAY, YEAR MANUFACTURED AND EQUIPMENT TYPE.

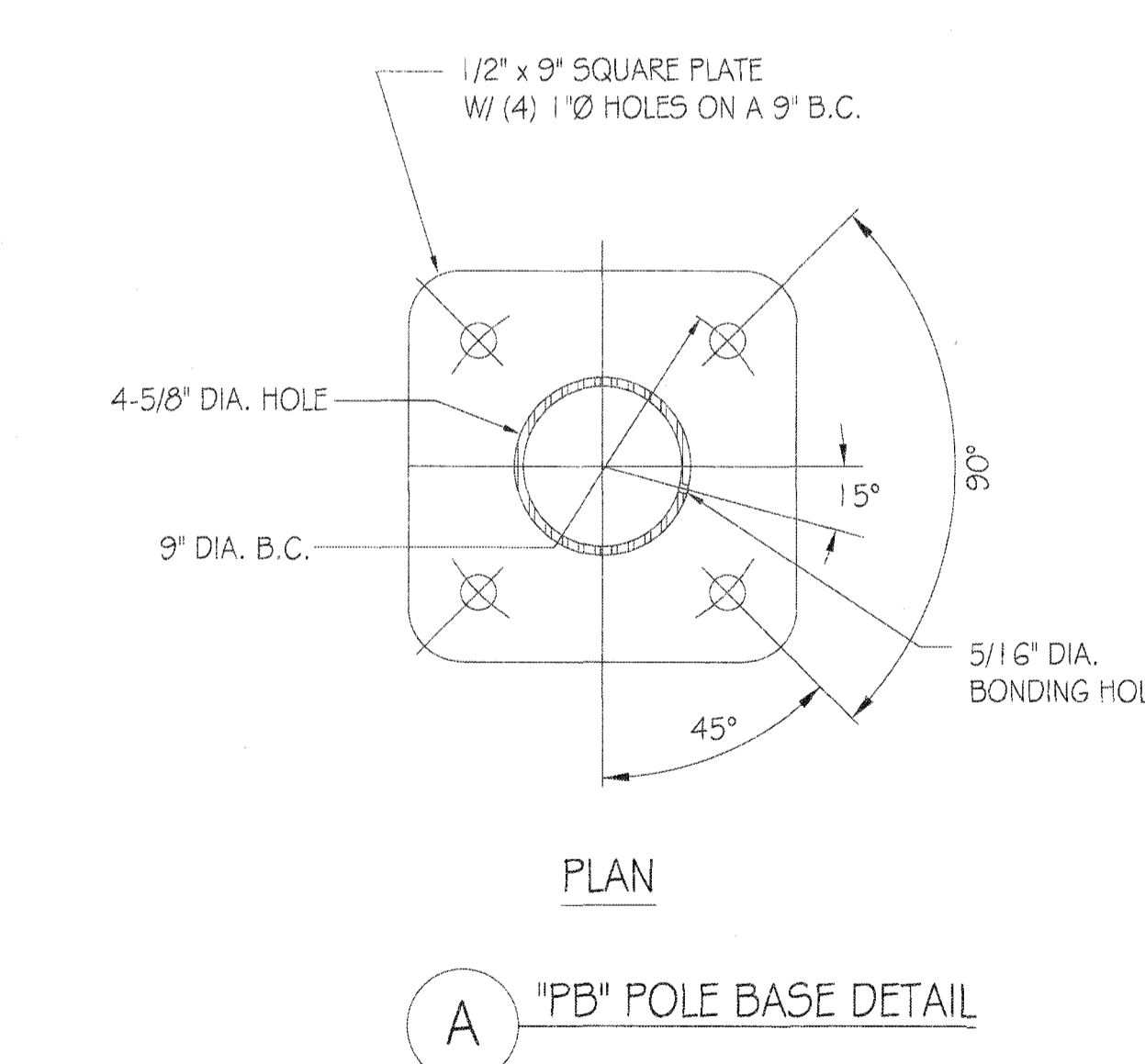
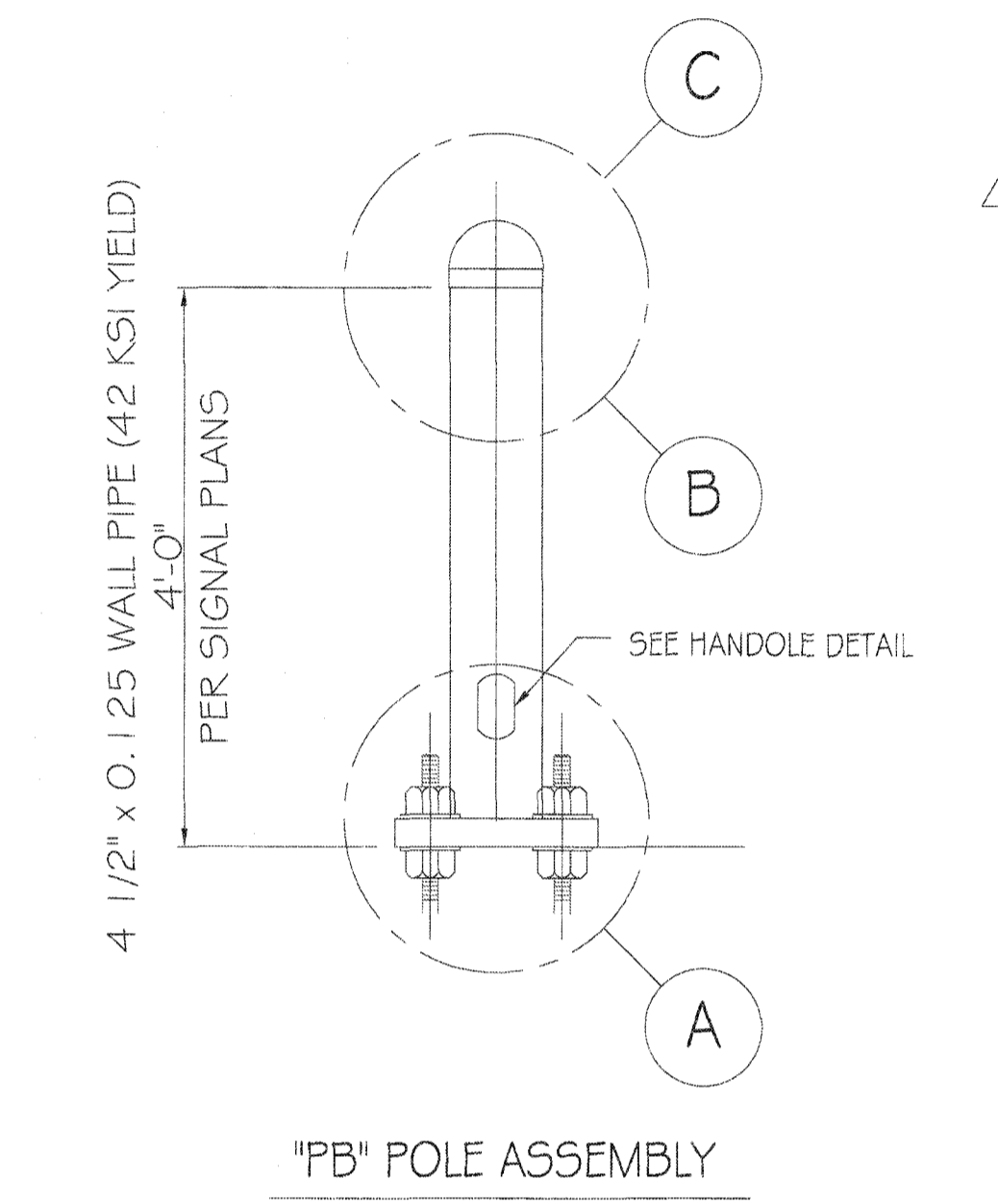
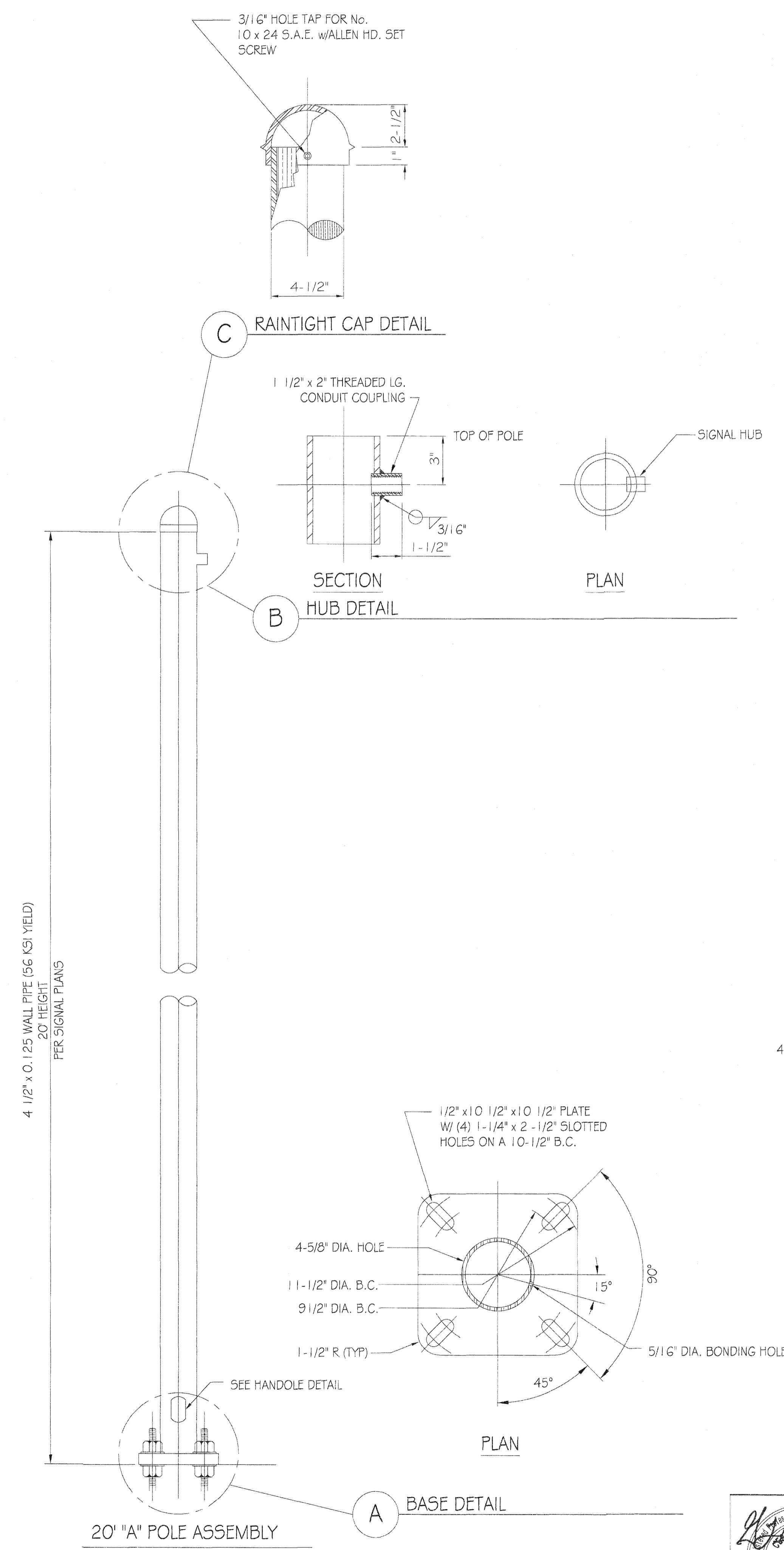
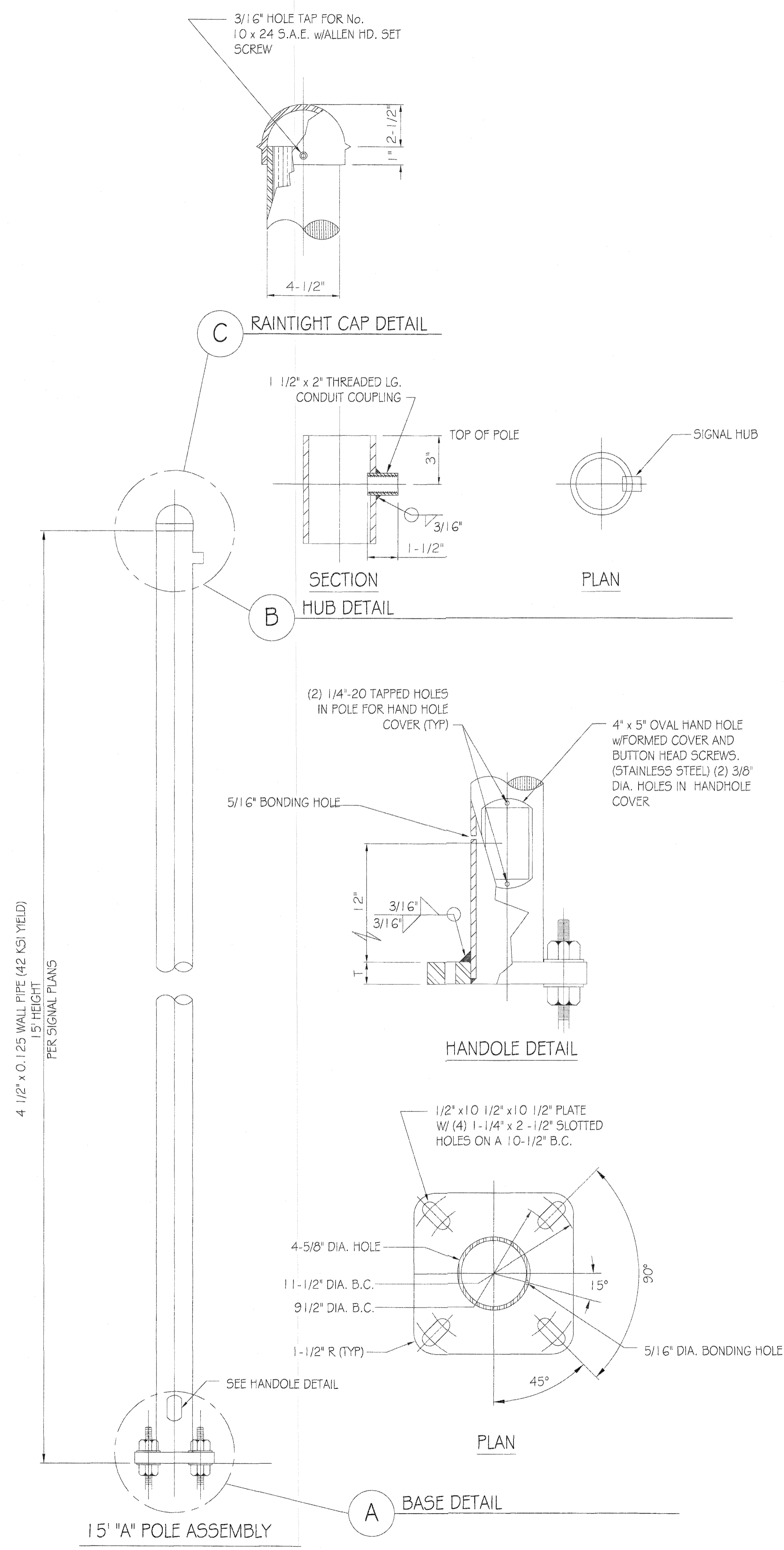

REVISION #	DATE	REVISION	DRAWN BY	APPROVED BY
1	9/1/2017	Added note #6 & Changed Sheet number	ZR	[Signature]

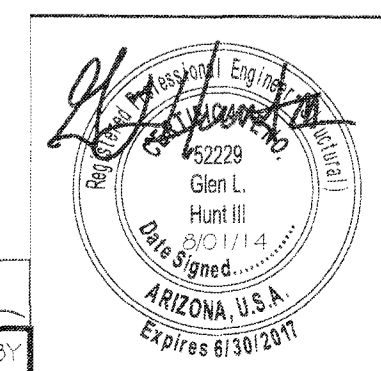

CITY OF PHOENIX, ARIZONA
STREET TRANSPORTATION DEPARTMENT
TRAFFIC SIGNAL STANDARD DETAILS

A POLE AND PB POLE

TPP File Number 10164 TS 1-6

DATE: 9-1-2017

TRAFFIC SIGNAL DETAILS		CITY OF PHOENIX, ARIZONA STREET TRANSPORTATION DEPARTMENT	
PROJECT #:	DR:	DES:	CK:
	DATE:	DATE:	DATE:
SCALE:	Q5 #:	SHEET NO:	TOTAL SHEETS:

F.H.W.A. REGION	STATE	PROJ. NO.	NO.	TOTAL
9	ARIZ.			

DR: DES: CK: DATE:

NOTES:
 1. DESIGN IN ACCORDANCE WITH AASHTO "STANDARD SPECIFICATIONS FOR STRUCTURAL SUPPORTS FOR HIGHWAY SIGNS, LUMINAIRES, AND TRAFFIC SIGNALS", 5TH EDITION, 2009.
 2. FOR DETAILS OF "Q" AND "R" POLES AND MAST ARMS, SEE ARIZONA DOT (ADOT) TRAFFIC SIGNALS AND LIGHTING STANDARD DRAWINGS.

ATTACHMENTS
 1 - 42" x 58" x 90# SIGNAL
 2 - 24" x 54" x 40# SIGNAL
 3 - 30" x 30" x 100# BLANK OUT SIGN
 4 - 36" x 36" x 15# SIGN

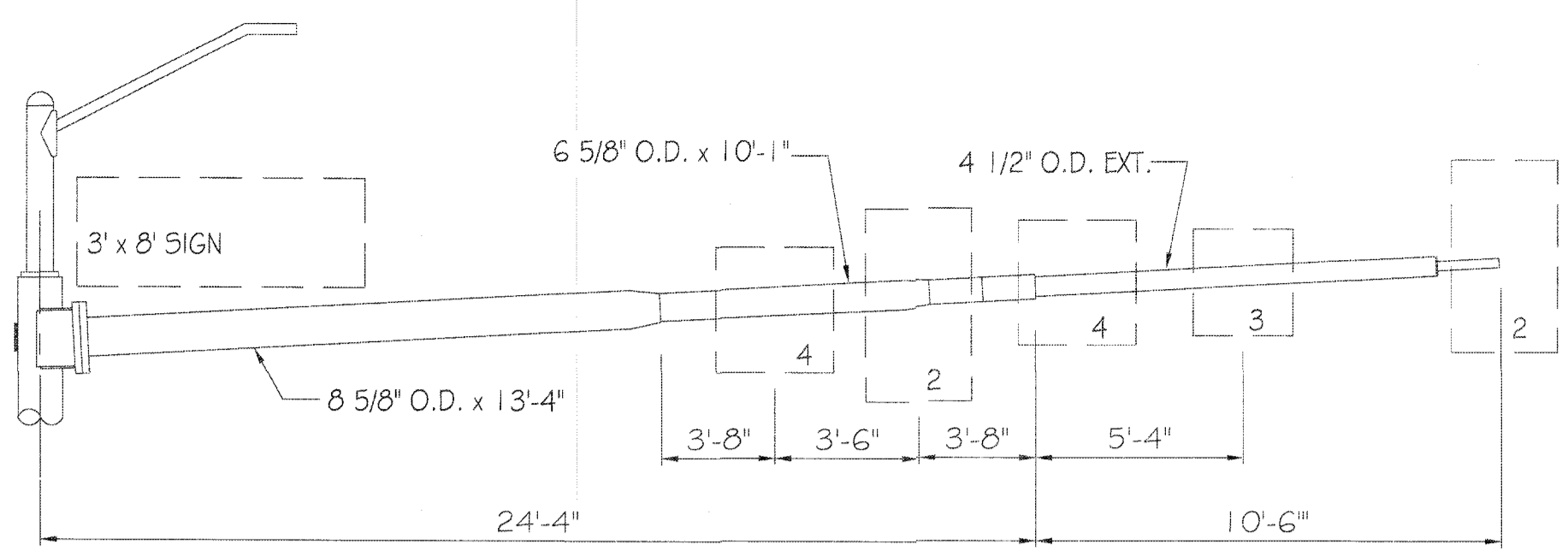

25' - 35' MAST ARM - SM & SR POLE

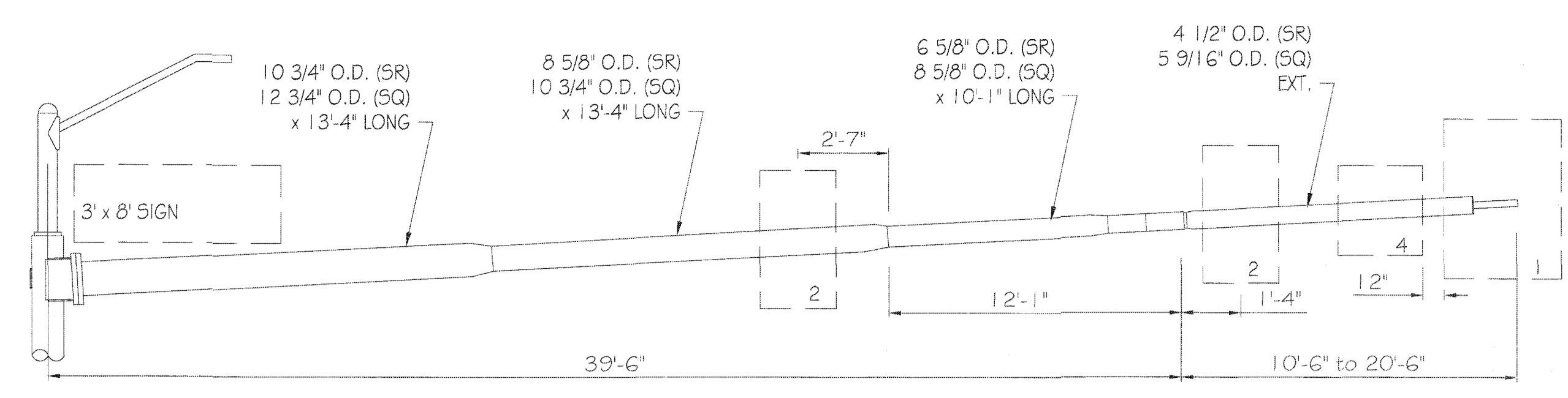

50' (SR), 55' (SQ), & 60' (SQ) MAST ARM

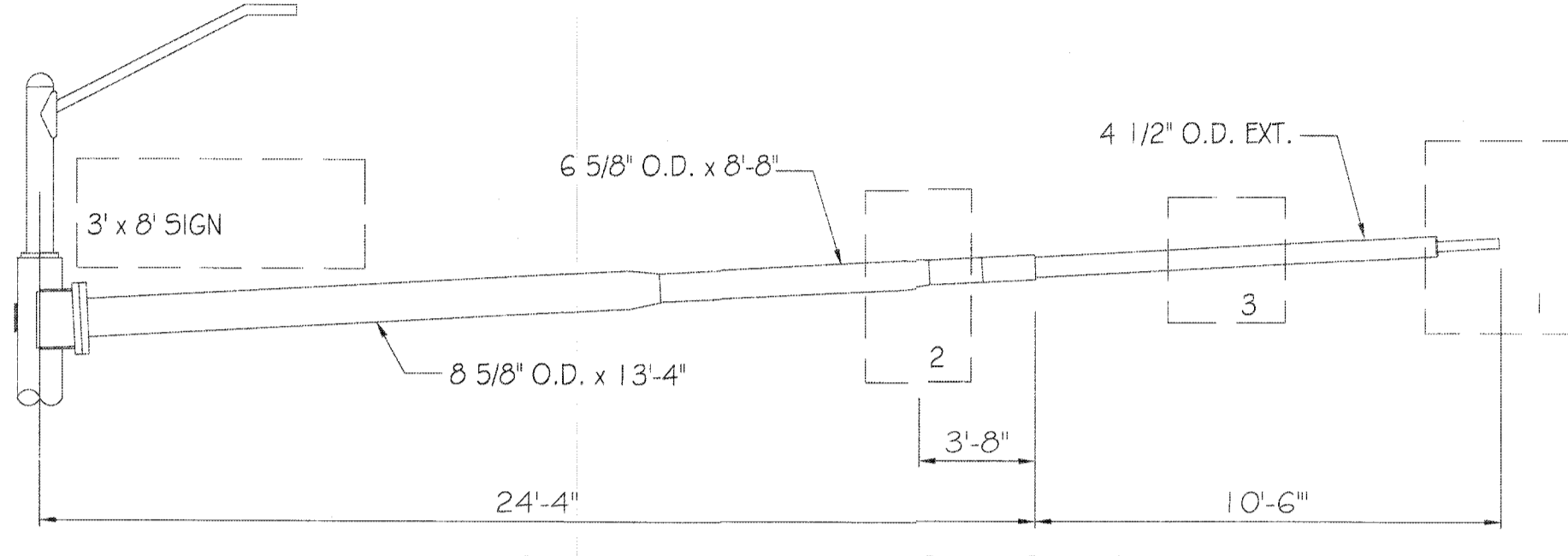

25' - 35' MAST ARM - SM & SR POLE

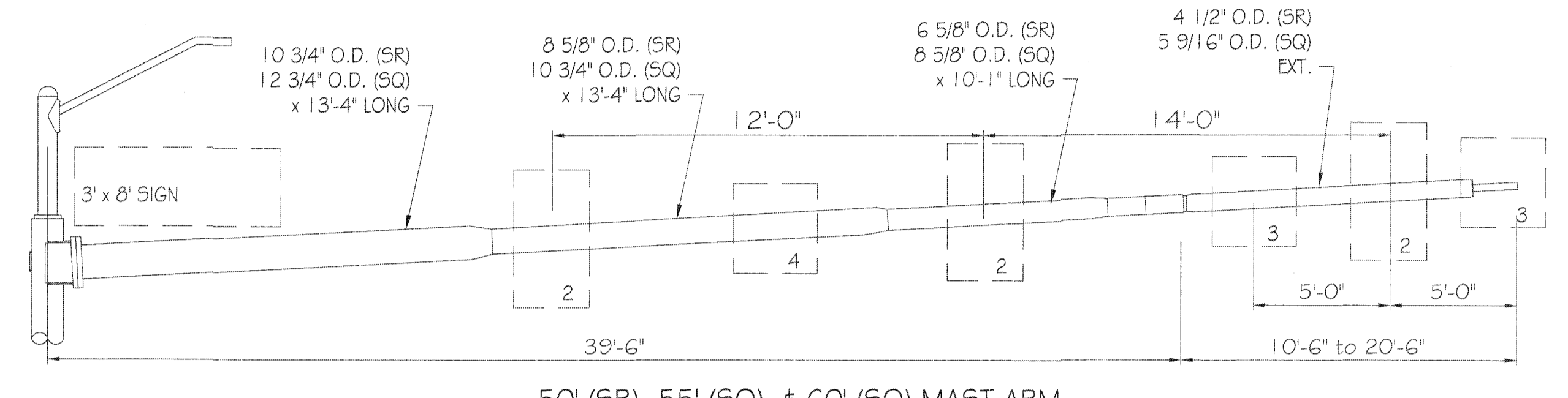

50' (SR), 55' (SQ), & 60' (SQ) MAST ARM

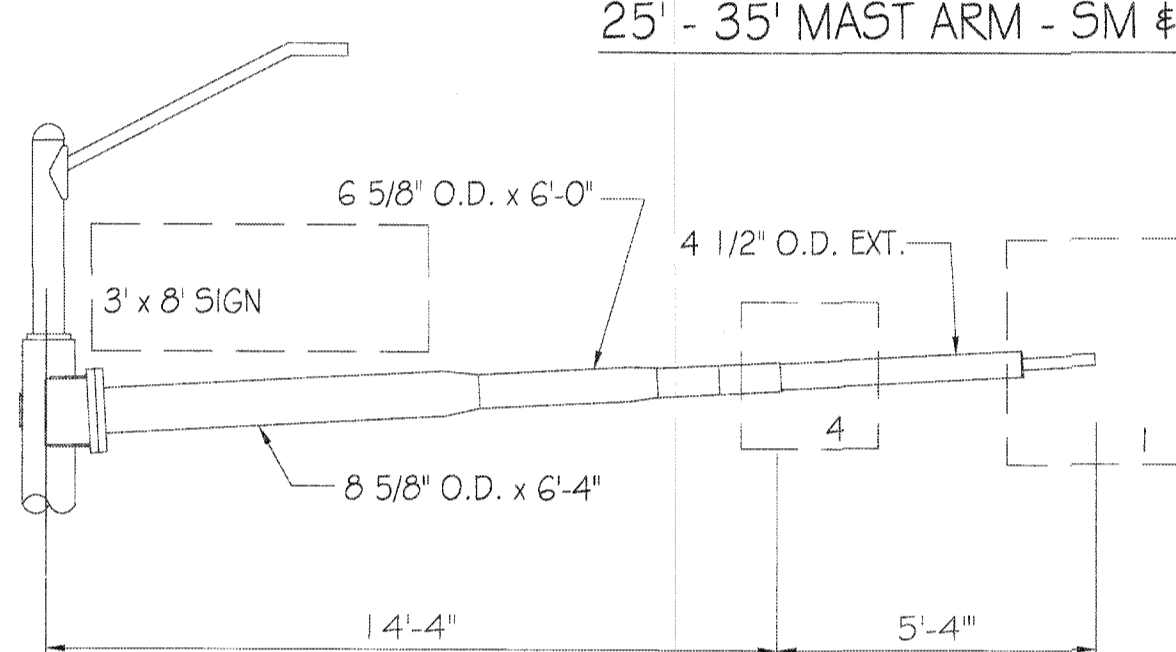

15' - 20' MAST ARM - SM & SR POLE

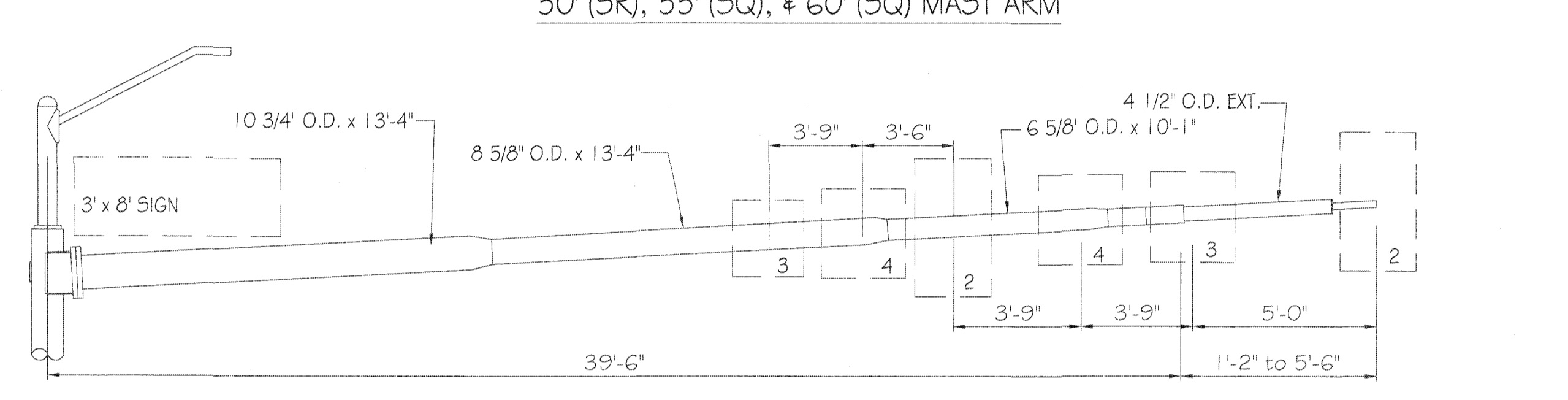

40' - 45' MAST ARM - SR POLE

4 1/2" O.D. EXT.	
CONTROLLER CABINET	WEIGHT
PAD MOUNT CABINET	325 POUNDS
POLE MOUNT CABINET	190 POUNDS

"SR" POLE AND MAST ARM EXTENSION WEIGHTS	
	WEIGHT
POLE ONLY	1050 POUNDS
MAST ARM - 45 FT	-

"A" POLE	
	WEIGHT
POLE ONLY	90 POUNDS

"SQ" POLE AND MAST ARM EXTENSION WEIGHTS	
	WEIGHT
POLE ONLY	1050 POUNDS
MAST ARM - 55 FT	-

"SM" POLE AND MAST ARM EXTENSION WEIGHTS	
	WEIGHT
POLE ONLY	710 POUNDS
MAST ARM - 25 FT TO 35 FT	-
MAST ARM - 15 FT TO 20 FT	225 POUNDS

	WEIGHT
LUMINAIRE RISER 5FT	40 POUNDS
LUMINAIRE ARM 8FT	-
LUMINAIRE FIXTURE N/A	20 POUNDS

"R" POLE AND MAST ARM EXTENSION WEIGHTS	
	WEIGHT
POLE ONLY	850 POUNDS
40 FT MAST ARM EXTENSION	-
5 FT MAST ARM EXTENSION	30 POUNDS
	20 POUNDS
	75 POUNDS

	WEIGHT
3' X 8' SMART SIGN WITH HARDWARE	225 POUNDS

	WEIGHT
DOG HOUSE	60 POUNDS
5 SECTION	-
3 SECTION	5 POUNDS

	WEIGHT
POLE ONLY	850 POUNDS
MAST ARM	-

	WEIGHT
	95 POUNDS
	500 POUNDS

CITY OF PHOENIX, ARIZONA
 STREET TRANSPORTATION DEPARTMENT
 TRAFFIC SIGNAL STANDARD DETAILS

TRAFFIC SIGNAL DETAILS
 CITY OF PHOENIX, ARIZONA
 STREET TRANSPORTATION DEPARTMENT

LOADS FOR
 POLES, MAST ARMS
 SIGNAL EQUIPMENT

TPP File Number 101G4 TS 1-7
 DATE: DATE: DATE: 9-1-2017
 SCALE: OS: #:

PROJECT #:	
DR:	DES:
DATE:	DATE:
SCALE:	OS: #:

REVISION #	DATE	REVISION	DRAWN BY	APPROVED BY
1	9/1/2017	Changed Sheet number	ZR	ABE

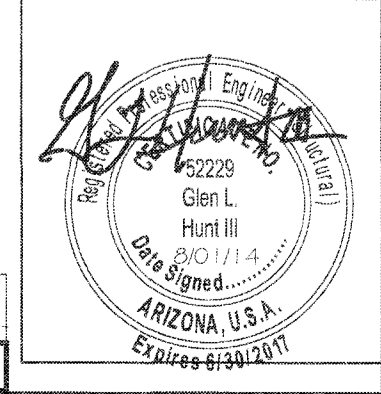

F.H.W.A. REGION	STATE	PROJ. NO.	NO.	TOTAL
9	ARIZ.			
DR:	DES:	CK:	DATE:	

PROJECT #:

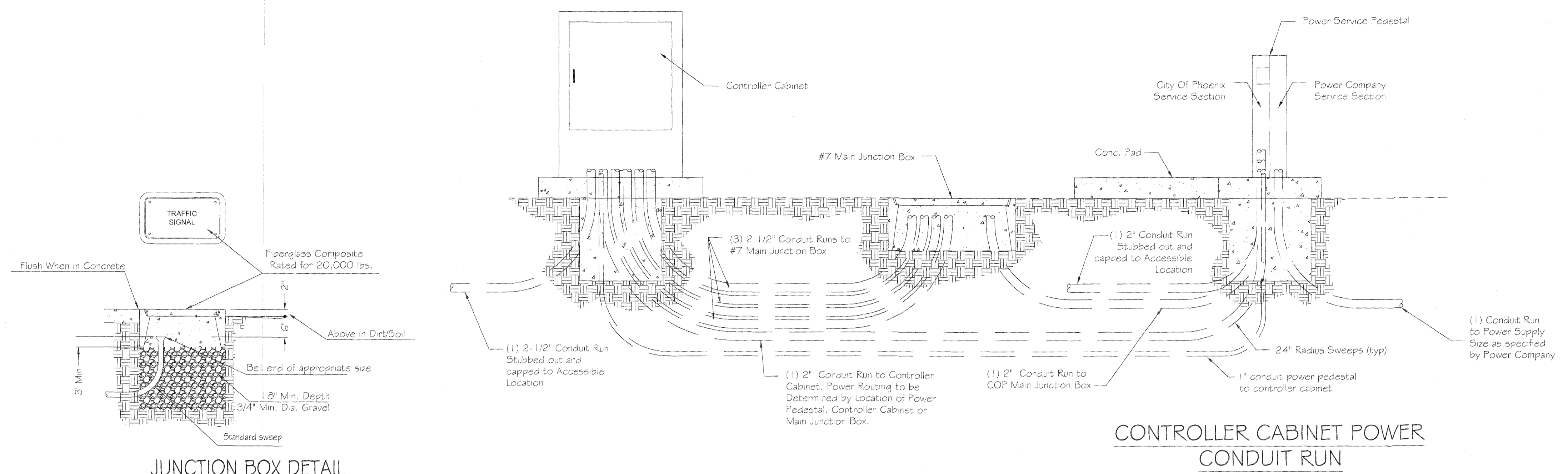

CONTROLLER CABINET POWER CONDUIT RUN

JUNCTION BOX:

- All Junction Box Lids shall be imprinted to say "TRAFFIC SIGNALS" and be a fiberglass composite rated for 20,000 lbs. and supplied with bolt lock downs. A minimum depth of eighteen (18) inches of three quarter (3/4) inch rock shall be installed under each Junction Box.
- All Conduit shall be installed between twentyfour (24) inches and forty (40) inches below finished grade, in straight lines, Junction Box to Junction Box or Junction Box to Pole Base, with one (1) 90° sweep on each end as specified in the plans. All Conduit entering Junction Boxes shall be vertical with the top of the Conduit six (6) inches below the bottom of the Junction Box cover. Conduit in all Foundations shall be located as close as possible to the center of the Foundation.

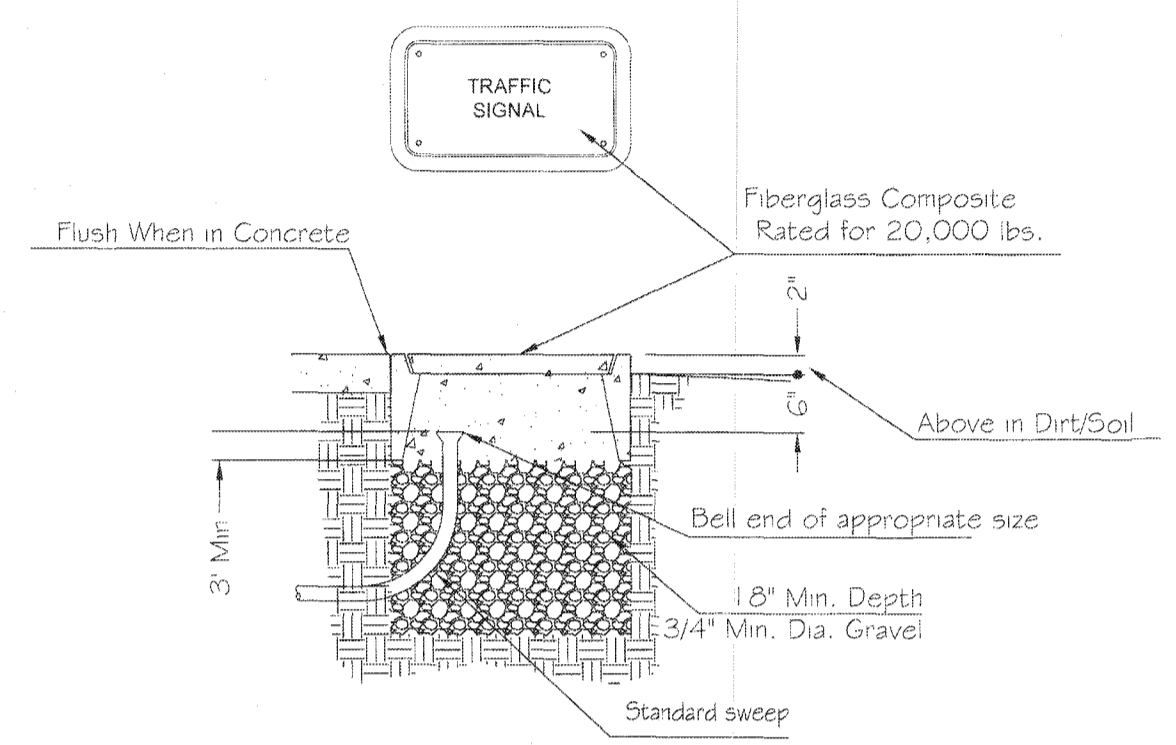

JUNCTION BOX DETAIL

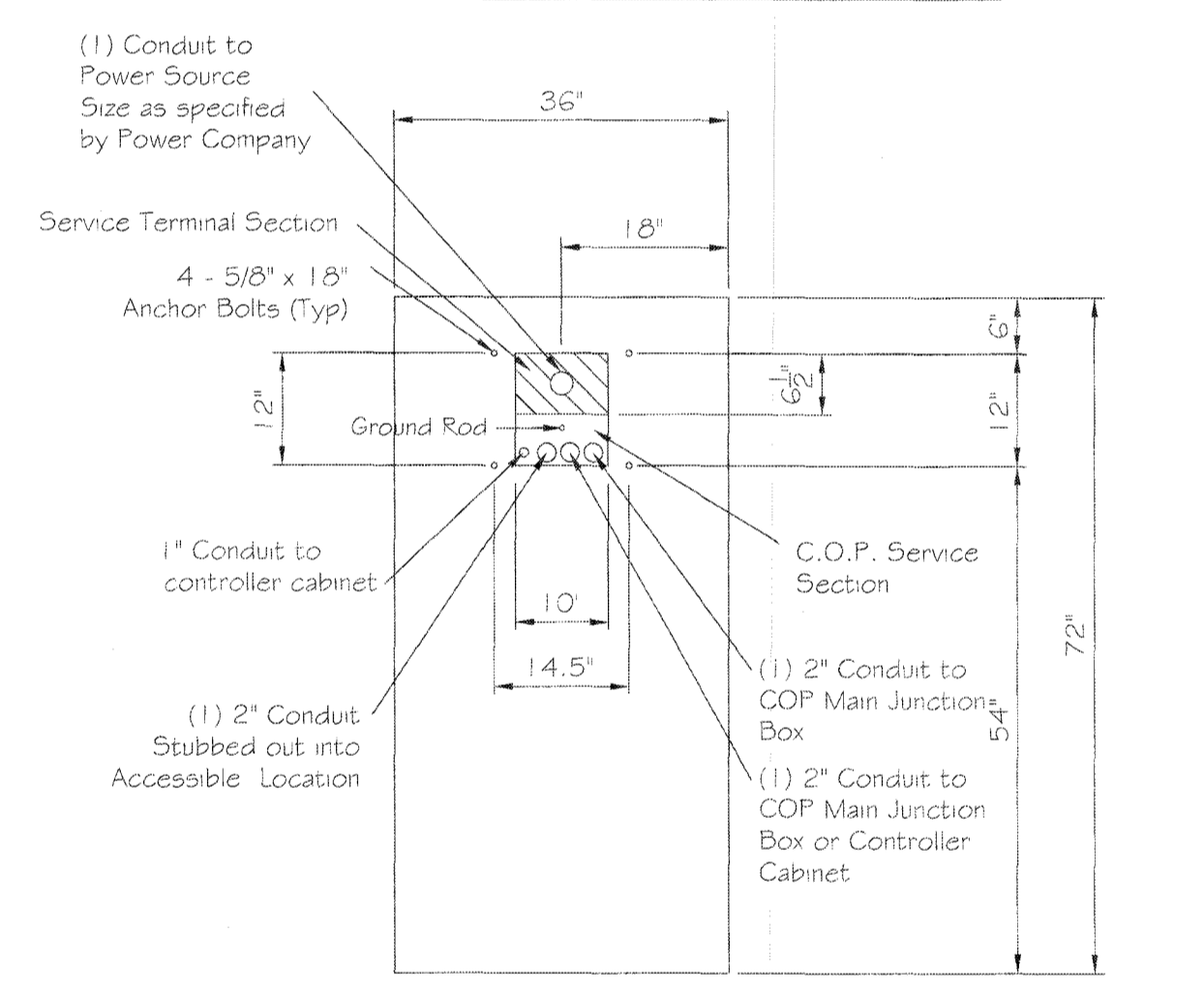

TOP VIEW

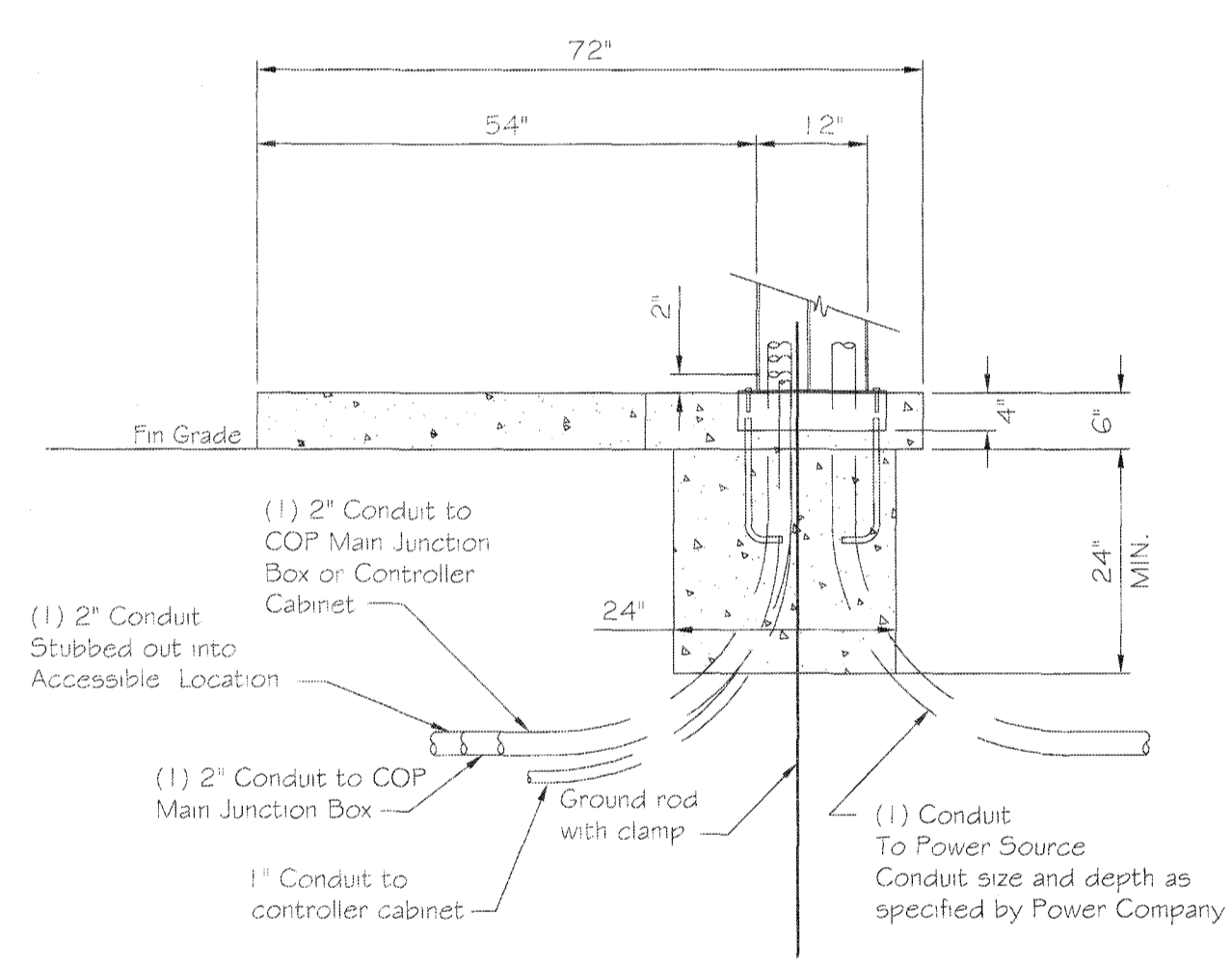

SIDE VIEW

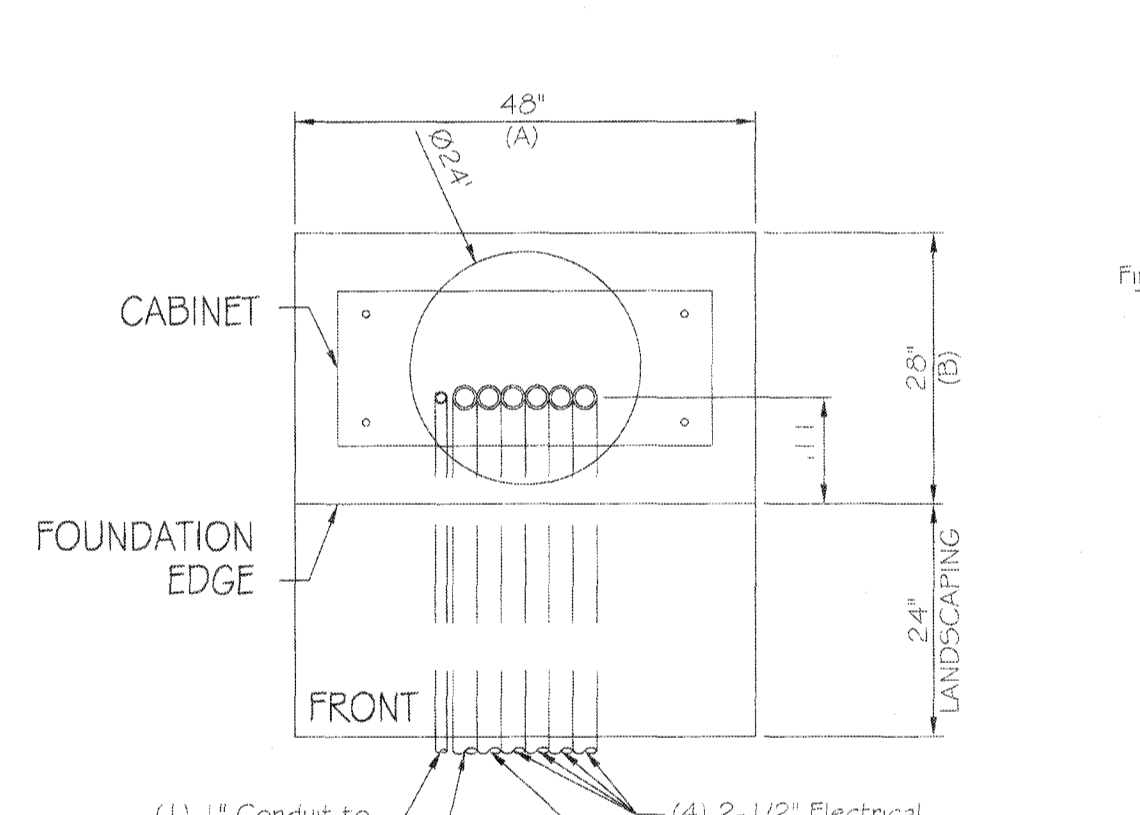

TOP VIEW

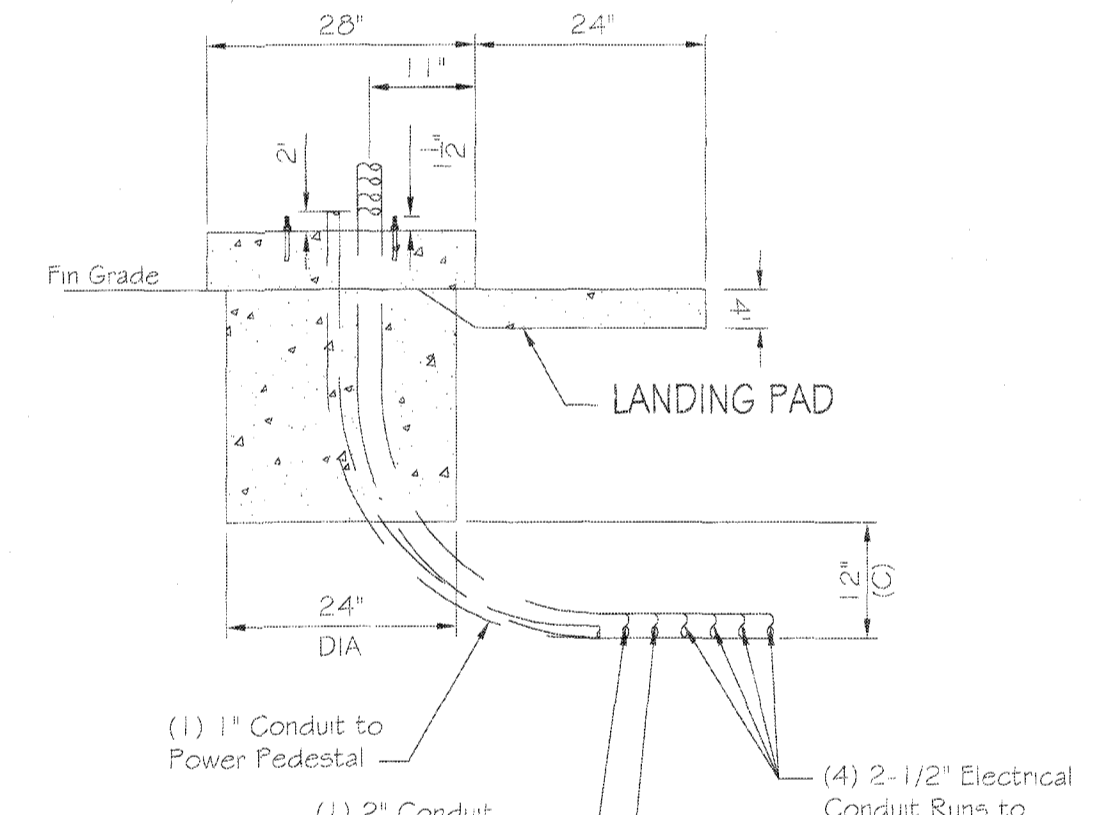

SIDE VIEW

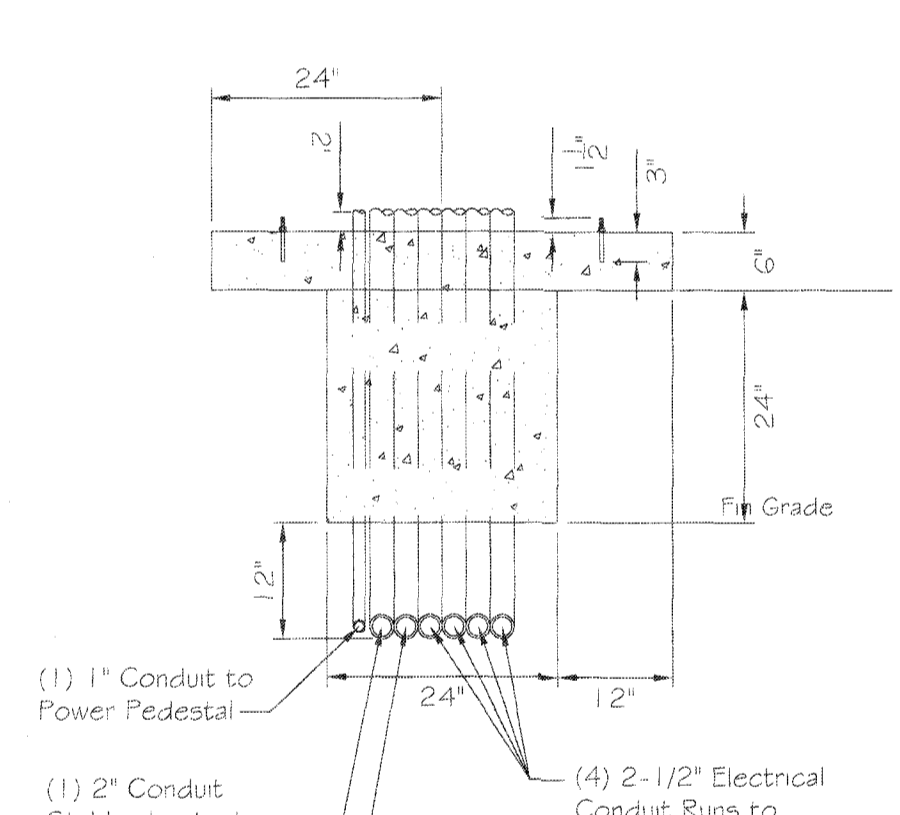

FRONT VIEW

CONTROLLER CABINET FOUNDATION BASE DETAIL

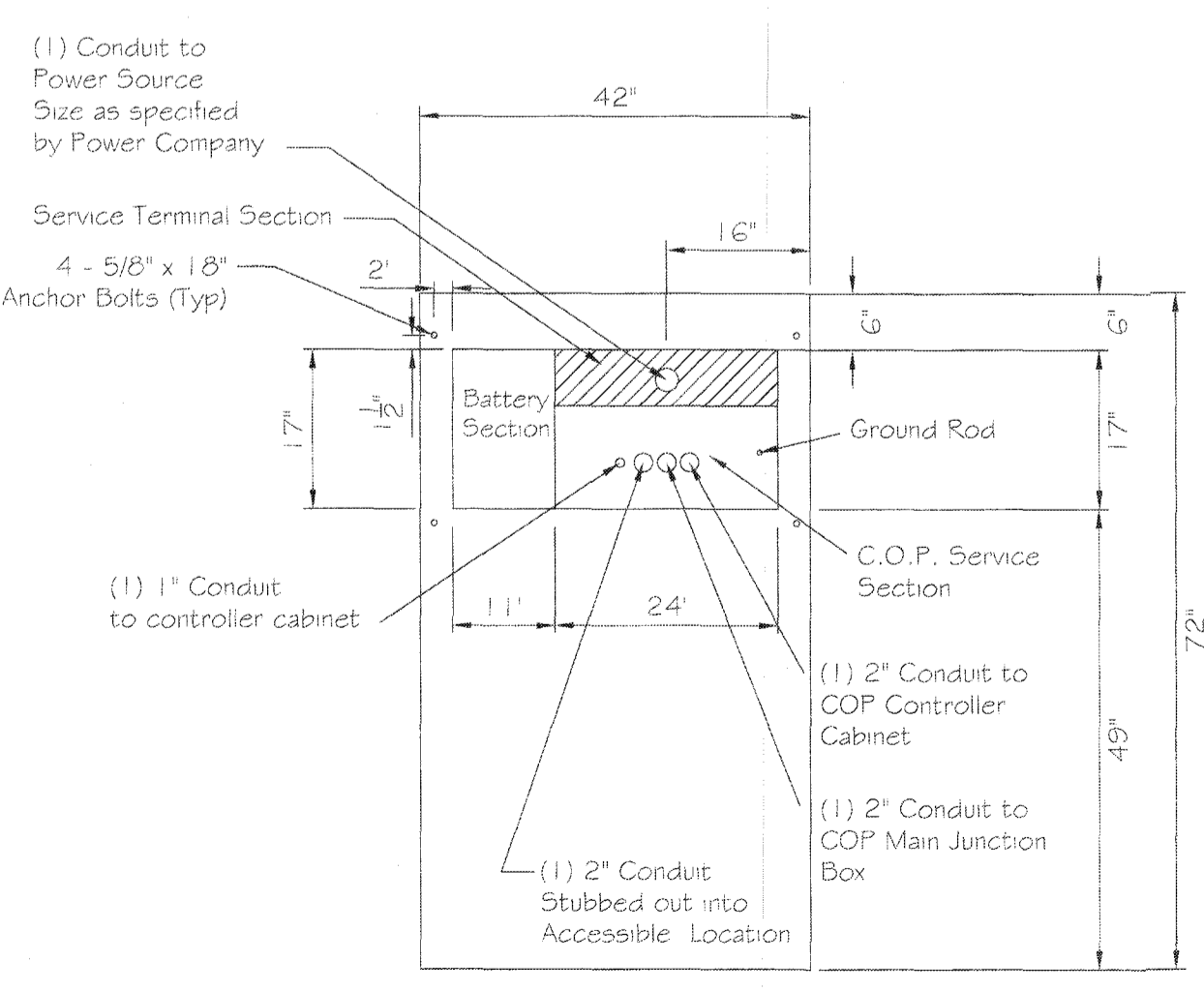

TOP VIEW

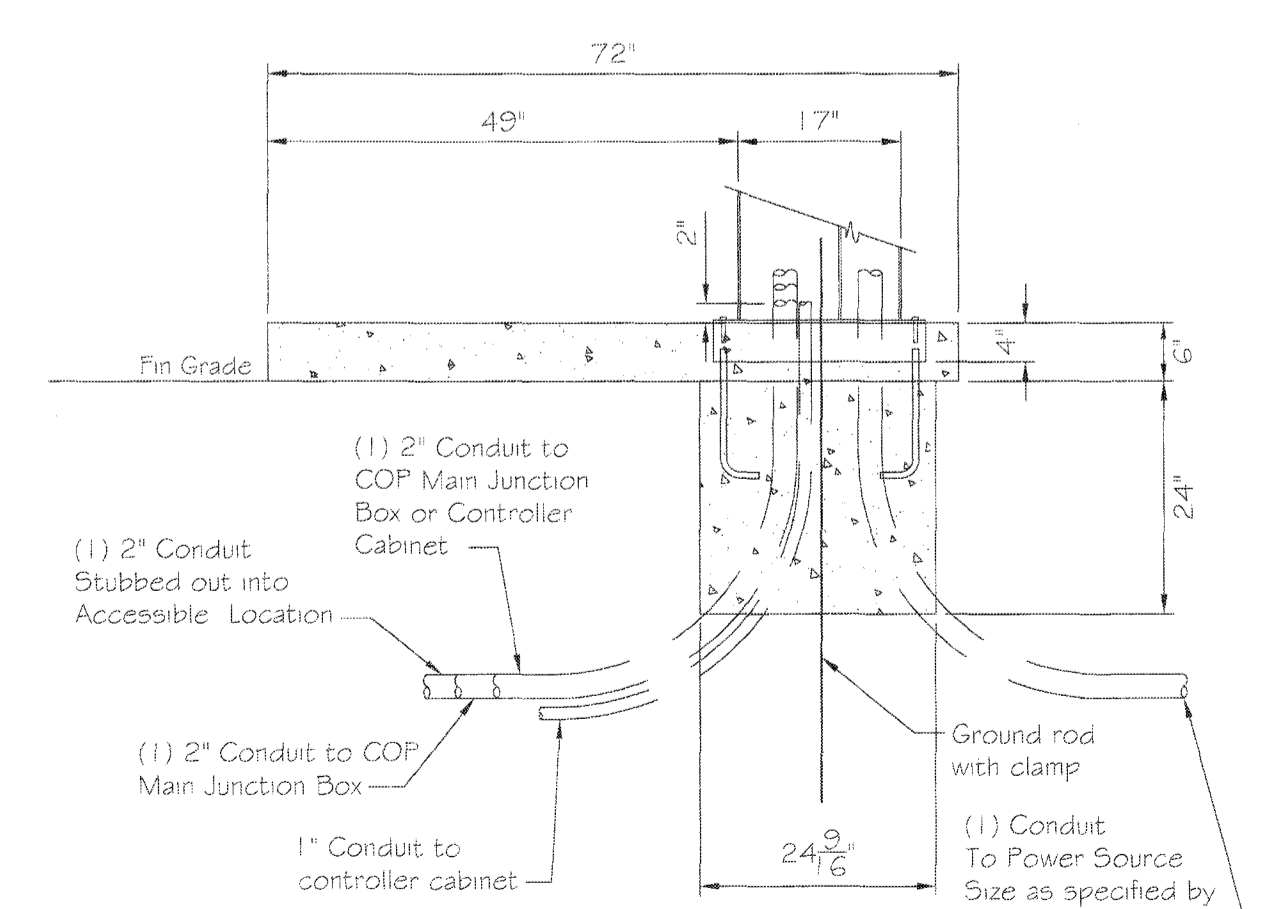

SIDE VIEW

BATTERY BACKUP POWER PEDESTAL BASE DETAIL TYPE "B"

CONTROLLER TYPE	FOUNDATION LENGTH 'A'	FOUNDATION WIDTH 'B'	CONDUIT SWEEP 'C'
Ø PHASE	48"	28"	24"

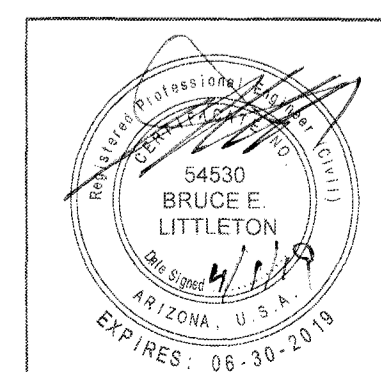

CITY OF PHOENIX, ARIZONA
STREET TRANSPORTATION DEPARTMENT
TRAFFIC SIGNAL STANDARD DETAILS

JUNCTION BOXES
FOUNDATIONS FOR CONTROLLER
AND POWER SERVICE PEDESTAL

TPP File Number 10164 TS 2-1
TRAFFIC SERVICES DEPUTY DIRECTOR
4-1-2019

"PER CITY OF PHOENIX CITY CODE CHAPTER 2, SECTION 2-26, THESE PLANS ARE FOR OFFICIAL USE ONLY & MAY NOT BE SHARED WITH OTHERS EXCEPT AS REQUIRED TO FULFILL THE OBLIGATIONS OF YOUR CONTRACT WITH THE CITY OF PHOENIX."

TRAFFIC SIGNAL DETAILS
CITY OF PHOENIX, ARIZONA
STREET TRANSPORTATION DEPARTMENT

PROJECT #:	DR:	DES:	CK:	SHEET NO:	TOTAL SHEETS:
SCALE:	DATE:			GS #:	

PROJECT #:

F.H.W.A. REGION	STATE	PROJ. NO.	NO.	TOTAL
9	ARIZ.			

DR: _____ DES: _____ CK: _____ DATE: _____

FOUNDATION GENERAL NOTES:

- FOUNDATION ELEVATIONS MUST BE WITHIN 1/4" OF FINISHED SIDEWALK GRADE.
- ALL FOUNDATION CONCRETE SHALL HAVE A MINIMUM COMPRESSIVE STRENGTH $P_c = 3000$ PSI AT 28 DAYS. CONCRETE MIX SHALL BE DESIGNED BY AN APPROVED LABORATORY. CONCRETE SHALL HAVE A MAXIMUM WATER/CEMENT RATIO OF 0.45. ALL CONCRETE CONSTRUCTION SHALL BE IN ACCORDANCE WITH ACI 318. "THE BUILDING CODE REQUIREMENTS FOR REINFORCED CONCRETE", LATEST EDITION. CEMENT SHALL BE TYPE I/II CONFORMING TO ASTM C-150. ALL AGGREGATE USED IN THE CONCRETE SHALL CONFORM TO ASTM C-33. MAXIMUM AGGREGATE SIZE TO BE 1 1/2". SLUMP 4" - 6"
- ALL REINFORCING STEEL SHALL CONFORM TO ASTM A615. VERTICAL BARS SHALL BE GRADE 60, AND TIES OR STIRRUPS SHALL BE A MINIMUM OF GRADE 40. THE PLACEMENT OF ALL REINFORCEMENT SHALL CONFORM TO ACI 315, "MANUAL OF STANDARD PRACTICE FOR DETAILING REINFORCED CONCRETE STRUCTURES", LATEST EDITION
- A 25' COIL OF #4 AWG STRANDED BARE COPPER GROUNDING ELECTRODE SHALL BE INSTALLED AT THE BASE OF SIGNAL POLE FOUNDATIONS AND EXTEND CENTERED, 2' ABOVE TOP OF FOUNDATION. CONDUCTOR SHALL BE INSTALLED 6" BELOW FOUNDATION AND COVERED WITH 6" OF SOIL PRIOR TO CONCRETE PLACEMENT.

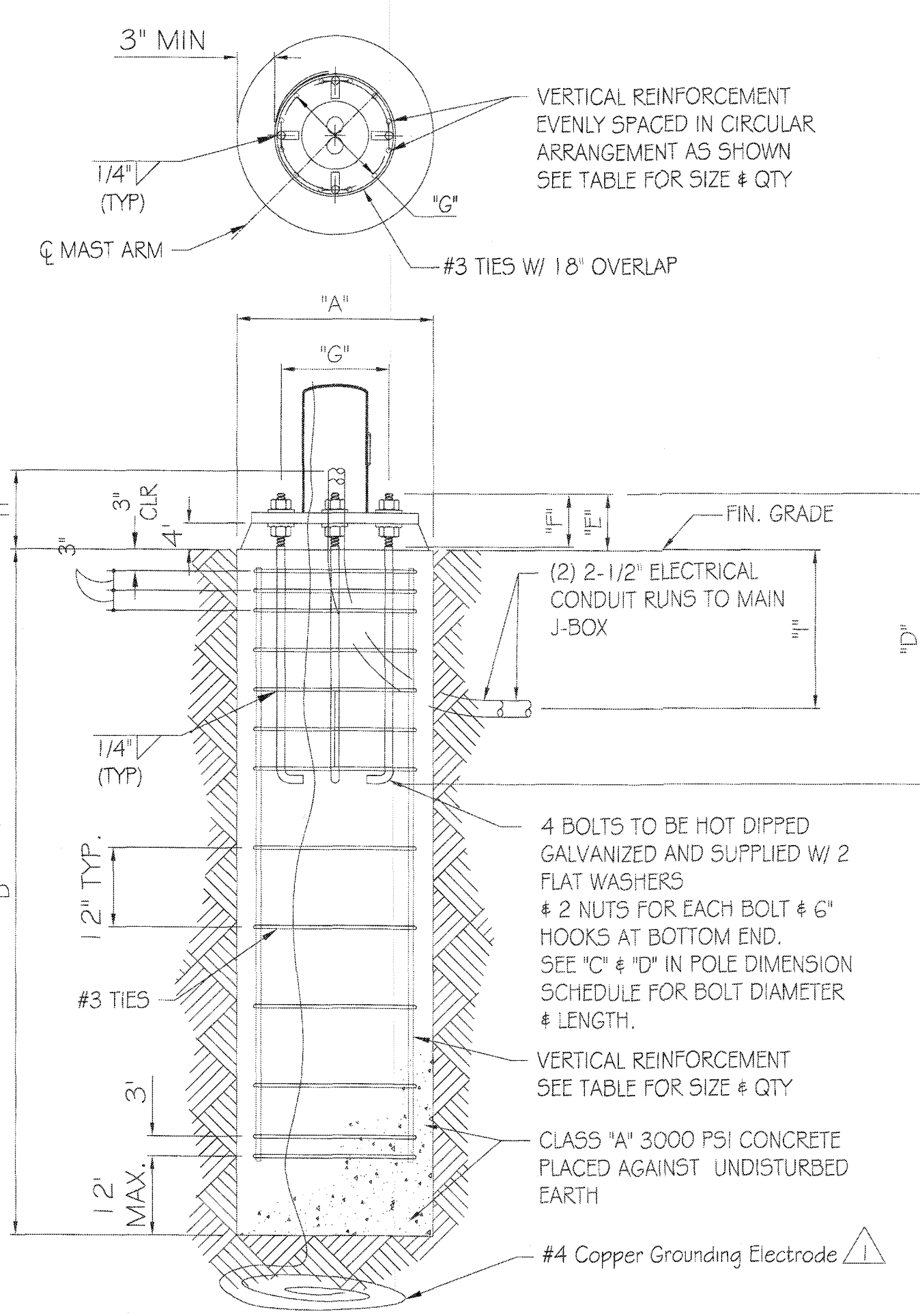

FOUNDATION, ANCHOR BOLT & REBAR CAGE DETAIL FOR SQ, SR, SM, & LM POLES

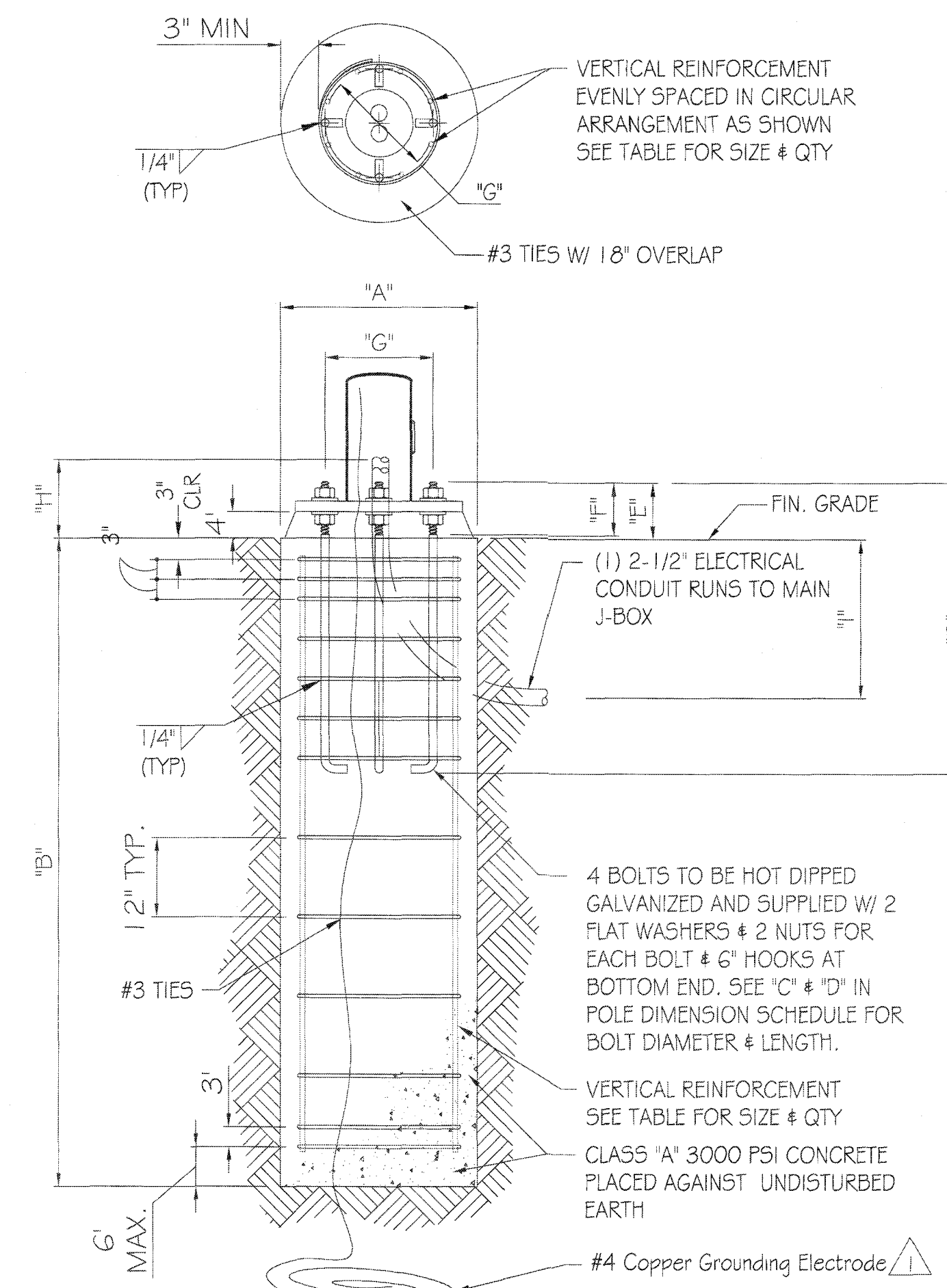

FOUNDATION, ANCHOR BOLT & REBAR CAGE DETAIL FOR "A" POLES

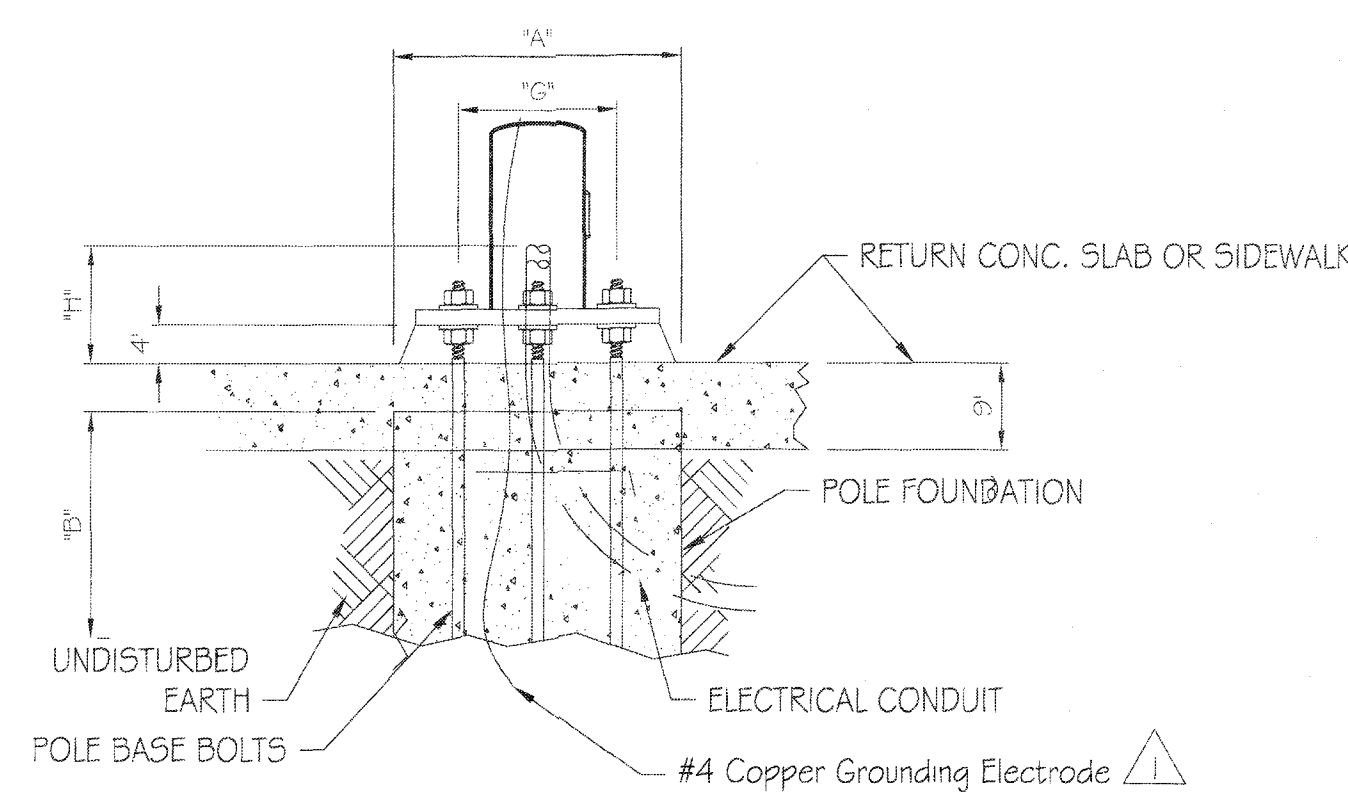

TYPICAL POLE FOUNDATION LOCATED WITHIN SIDEWALK SLAB

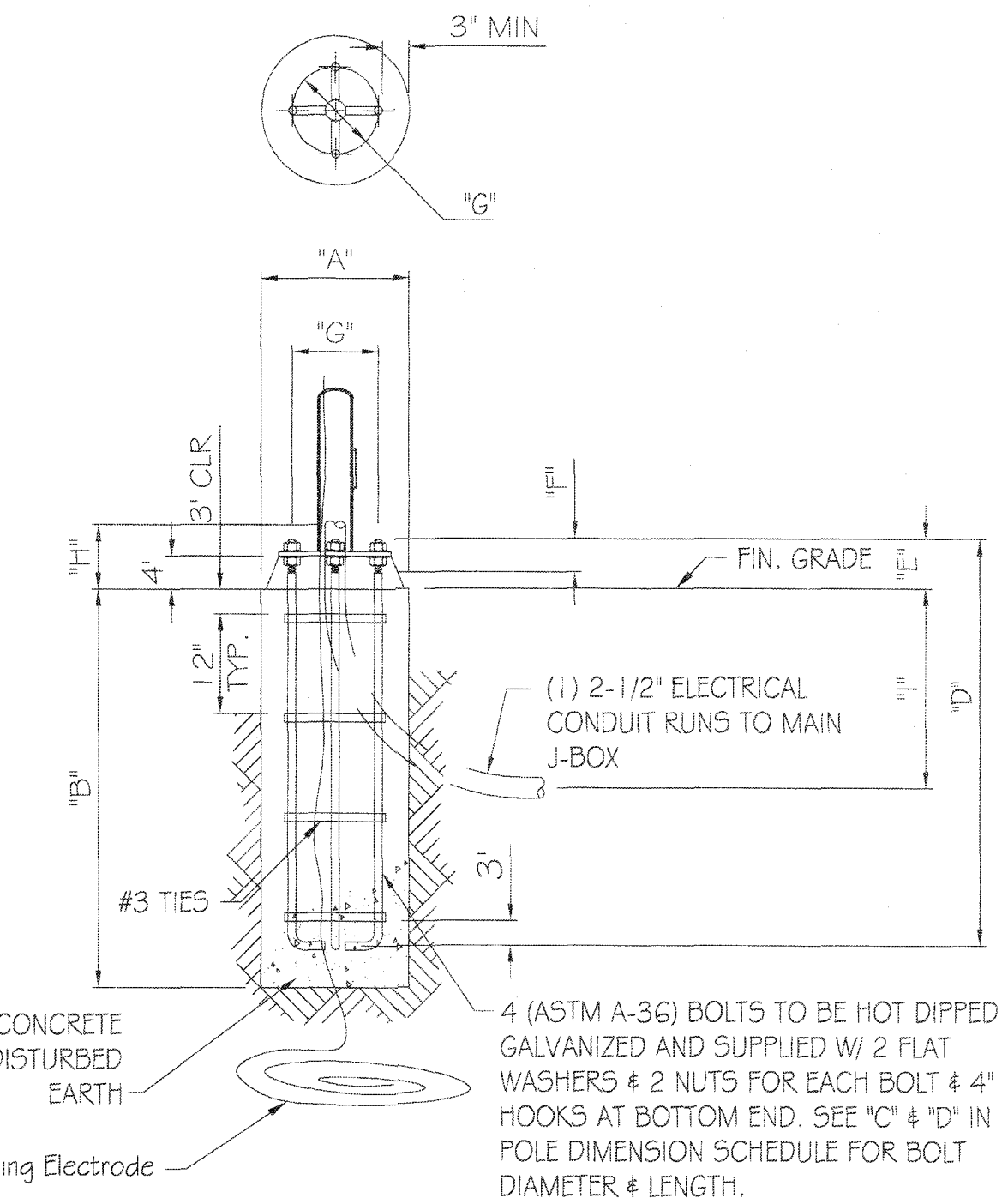

FOUNDATION & ANCHOR BOLT CAGE DETAIL FOR "PB" POLES

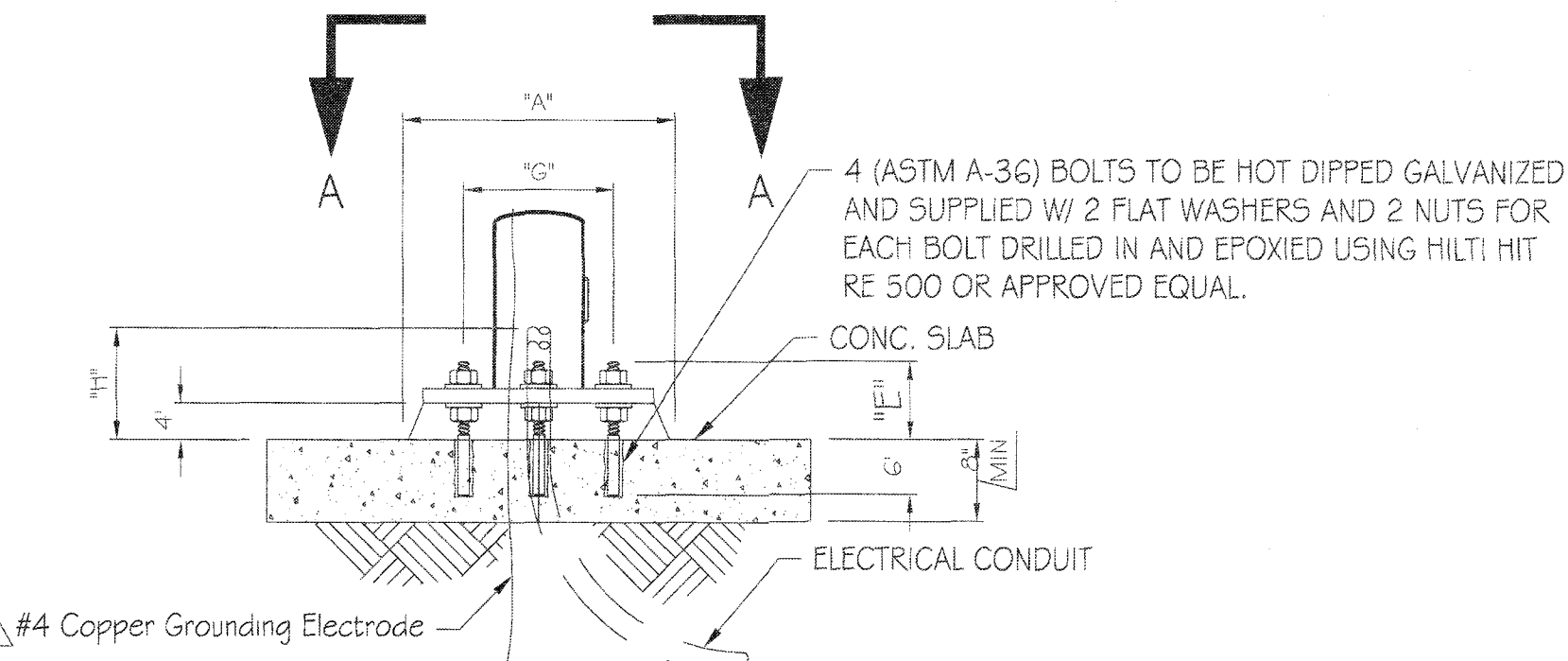

"PB" POLE SLAB FOUNDATION LOCATED ON SIDEWALK SLAB

FOUNDATION POLE TYPE	POLE DETAIL (ft.)		LUMINAIRE ADAPTABILITY	FOUNDATION DETAIL (in.)		VERT. REINFORCEMENT		BOLT DETAIL (in.)					* CONDUIT DETAIL			
	POLE HEIGHT	MAST ARM LENGTH		'A' WIDTH	'B' DEPTH	REBAR QUANTITY	REBAR SIZE	ASTM MATERIAL GRADE	"C" DIAMETER	"D" LENGTH OVERALL	"E" PROJECTION	"F" THREAD	"G" BOLT CIRCLE	"H" CLEAR	"I" MIN. DEPTH	CONDUIT QUANTITY
TYPE "SQ"	20	55-60	YES	36	156	12	#6	F 1554-55	2	66	8 1/2	10	19	12	24	2
				30	186	10	#6	F 1554-55	2	66	8 1/2	10	18	12	24	2
TYPE "SR"	20	15-50	YES	36	138	12	#6	F 1554-55	2	66	8 1/2	10	18	12	24	2
				30	168	10	#6	F 1554-55	2	66	8 1/2	10	18	12	24	2
TYPE "SM"	20	15-35	YES	36	120	12	#6	F 1554-55	1 1/2	54	8 1/2	8	16 1/2	12	24	2
				30	132	10	#6	F 1554-55	1 1/2	54	8 1/2	8	16 1/2	12	24	2
TYPE "LM"	20	N/A	YES	36	84	12	#6	F 1554-55	1 1/2	44	7	6	12 1/2	12	24	2
TYPE "A"	15-20	N/A	N/A	18	72	8	#5	F 1554-36	1	36	6	4	10 1/2	12	24	1
TYPE "PB"	4	N/A	N/A	18	36**	N/A	N/A	F 1554-36	3/4	30	6	4	9	12	24	1

*CONDUIT SHALL ENTER 24" MINIMUM DEPTH, VERTICALLY, THROUGH THE BOTTOM OF THE FOUNDATION
 **UNLESS INSTALLED ON SLAB FOUNDATION PER DETAIL ON THIS SHEET

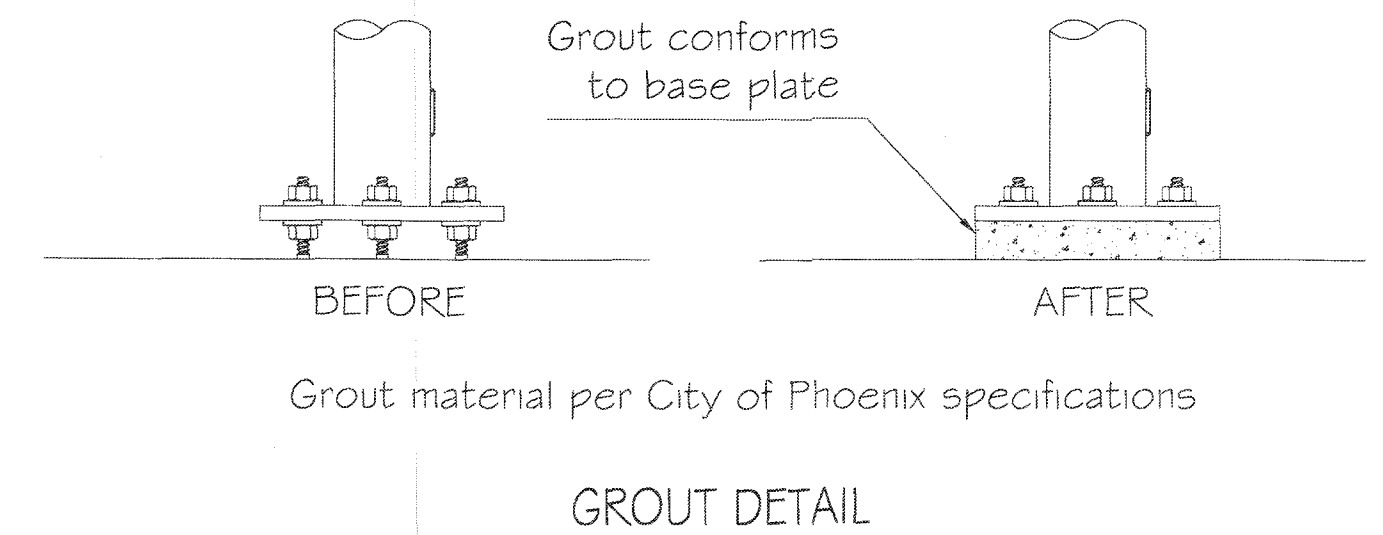

GROUT DETAIL

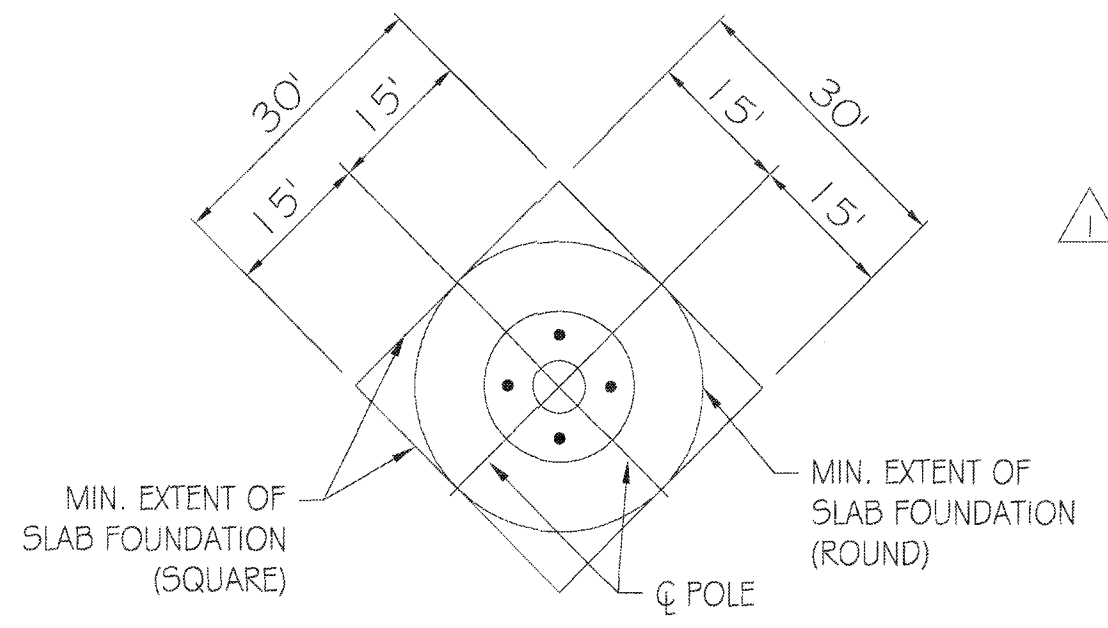

SECTION A-A

REVISION #	DATE	DESCRIPTION	DRAWN BY	APPROVED BY
1	4/1/2019	Added #4 copper grounding electrode to all details	ZR	Bec

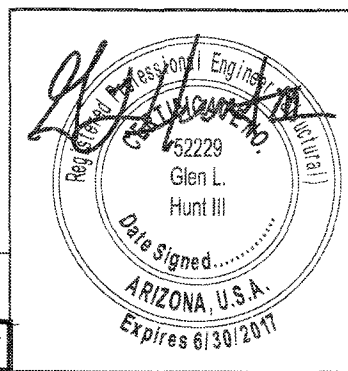

CITY OF PHOENIX, ARIZONA
 STREET TRANSPORTATION DEPARTMENT
 TRAFFIC SIGNAL STANDARD DETAILS

POLE FOUNDATIONS

TPP File Number 10164 TS 2-2
 DATE: 5-8-2017

TRAFFIC SIGNAL DETAILS
 CITY OF PHOENIX, ARIZONA
 STREET TRANSPORTATION DEPARTMENT

PROJECT #:

DR:	DES:	CK:	SHEET	TOTAL
DATE:	DATE:	DATE:	NO:	SHEETS

SCALE: _____ Q5. #:

F. H. W. A. REGION	STATE	PROJ. NO.	NO.	TOTAL
9	ARIZ.			

DR: DES: CK: DATE:

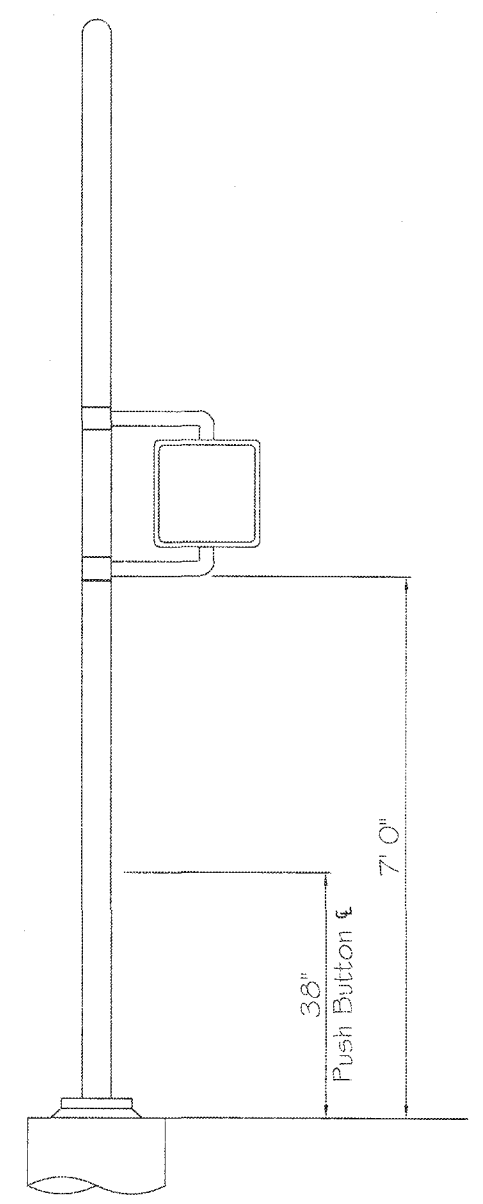

TYPE A POLE
PED SIGNAL

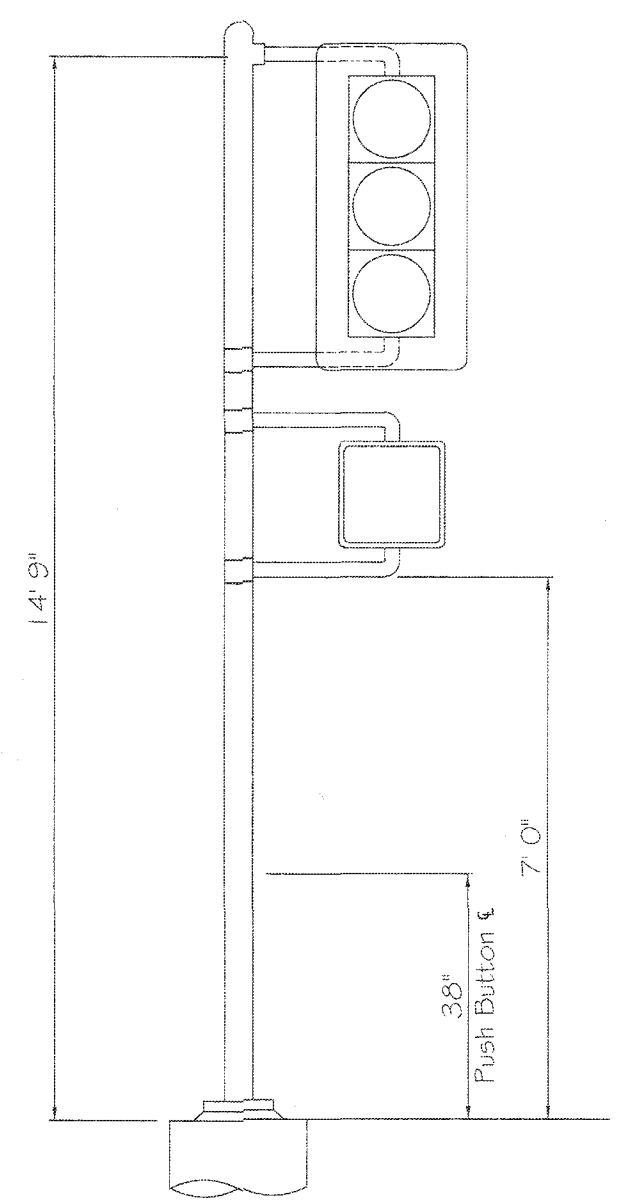

TYPE A POLE
12" VEHICLE SIGNAL AND PED SIGNAL

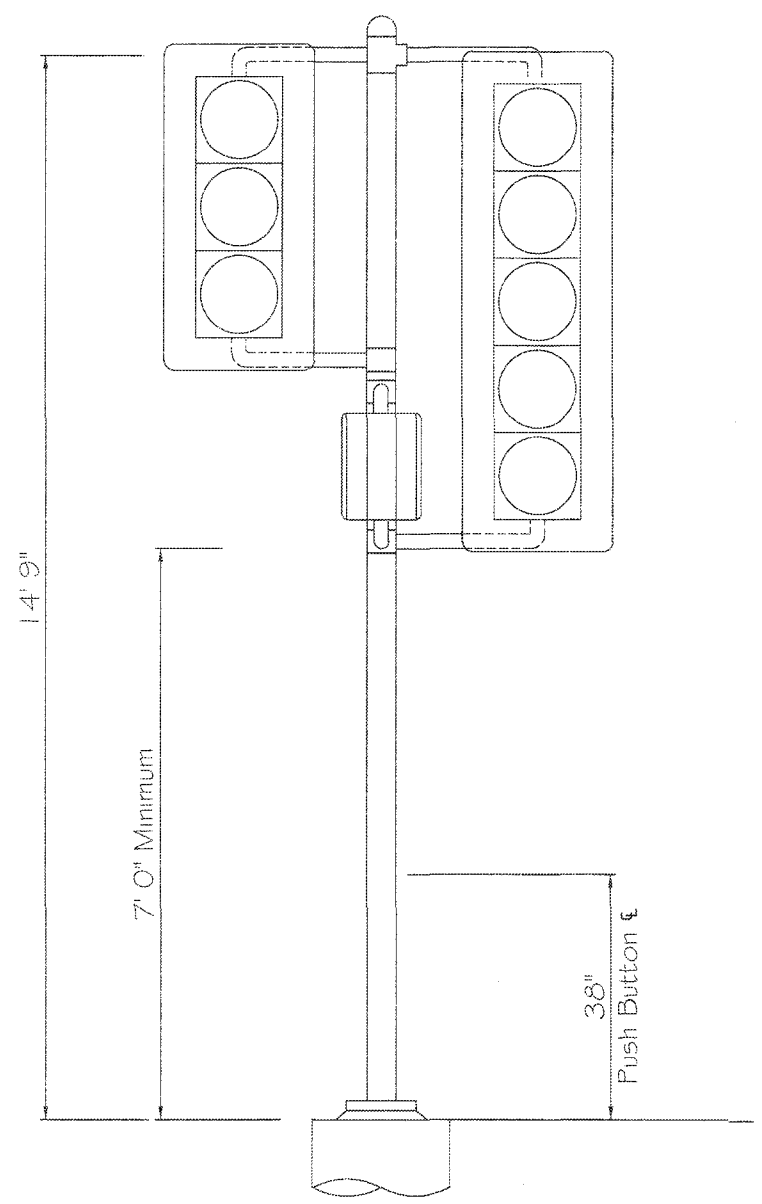

TYPE A POLE
12" 5 SECTION VEHICLE SIGNAL
AND PED SIGNAL

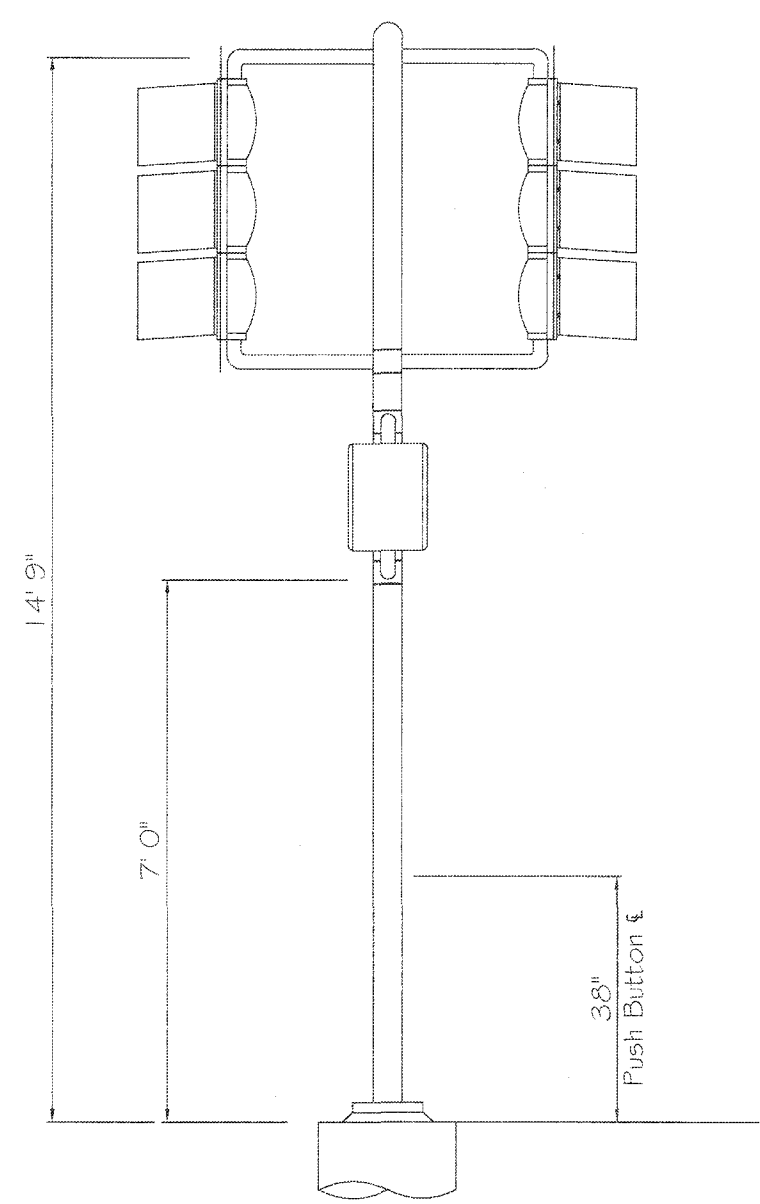

TYPE A POLE
12" BACK TO BACK VEHICLE SIGNAL
AND PED SIGNAL

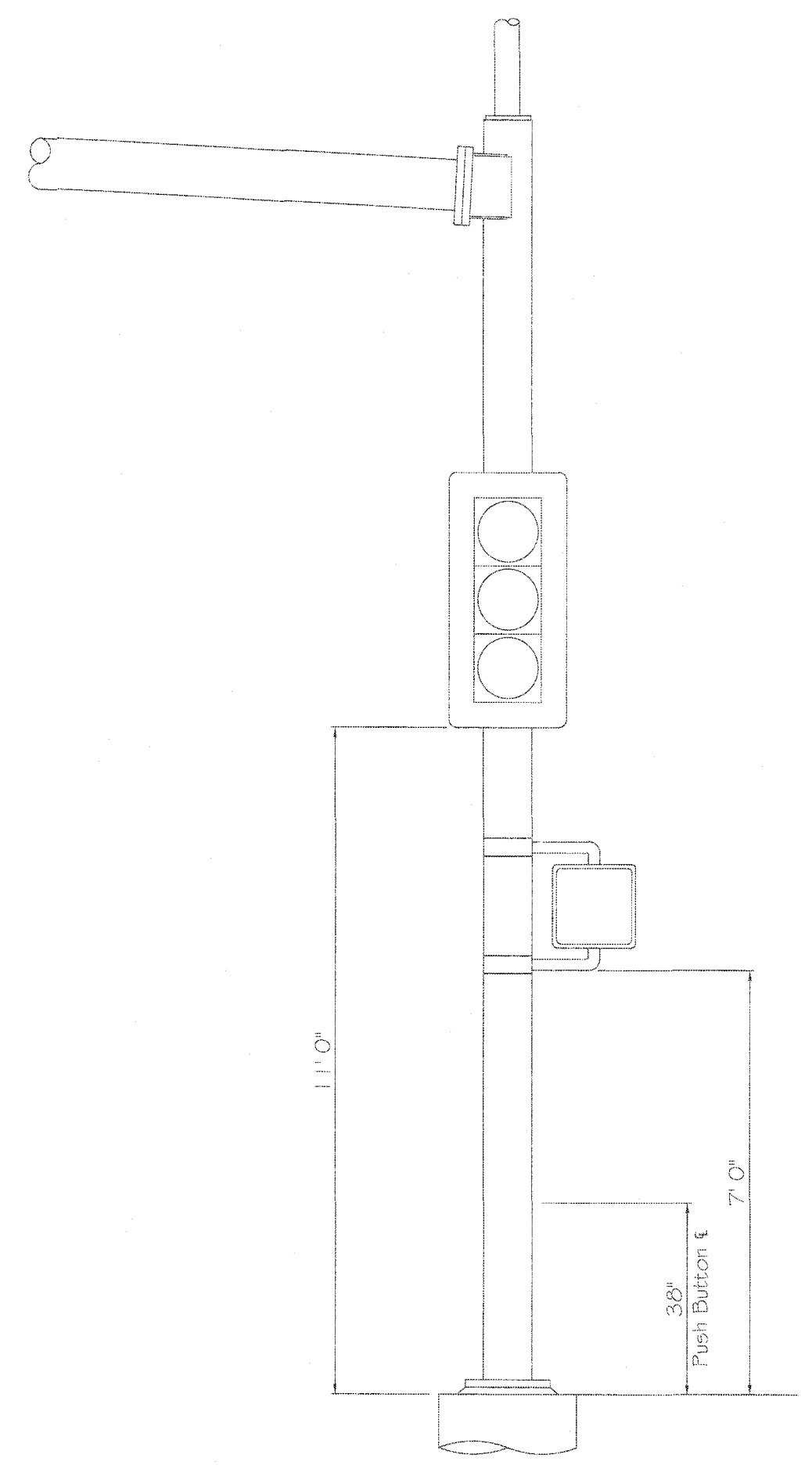

TYPE SM OR SR POLE
12" VEHICLE SIGNAL HEAD
AND PED SIGNAL

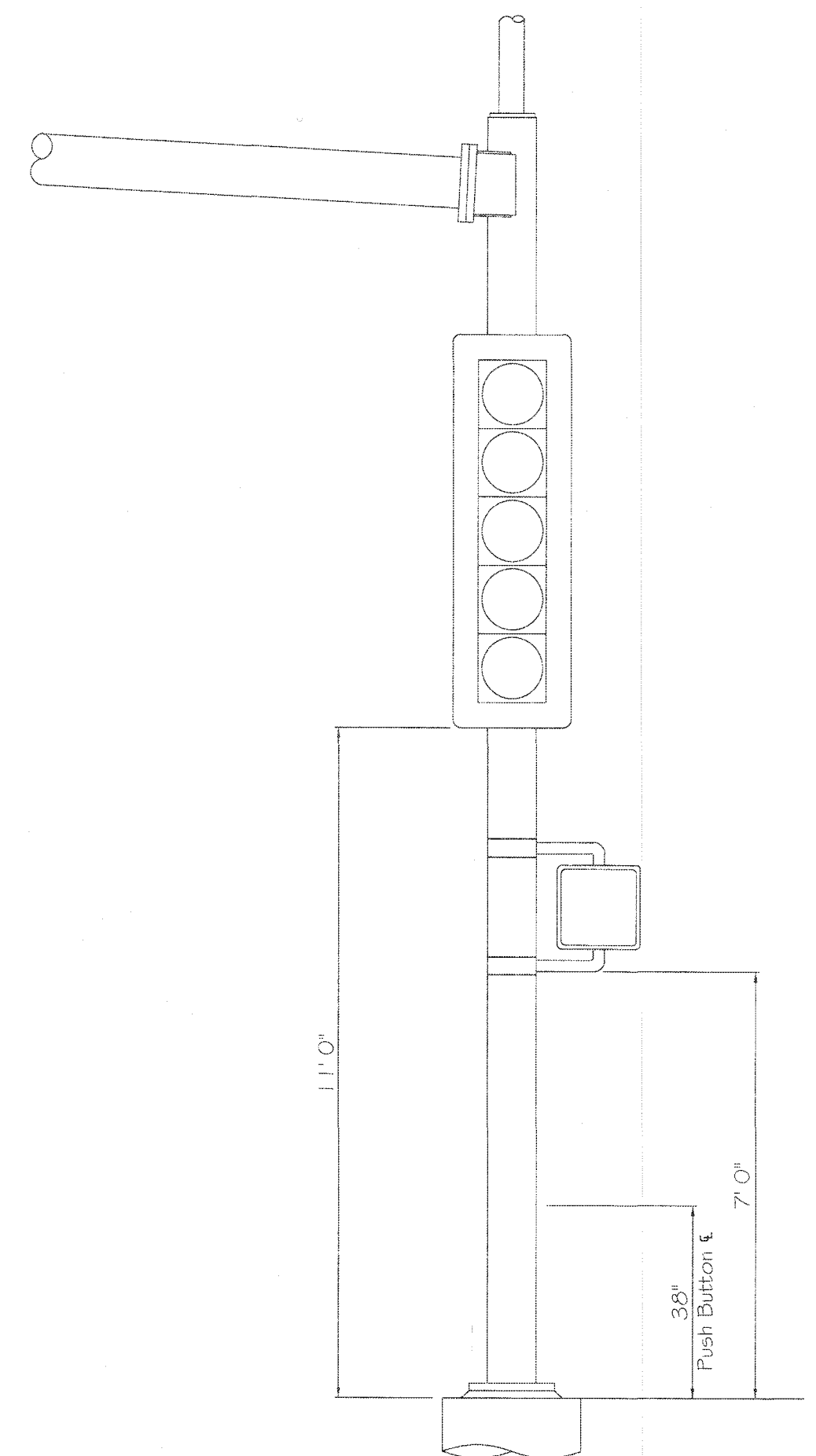

TYPE SM OR SR POLE
12" 5 SECTION VEHICLE SIGNAL HEAD
AND PED SIGNAL

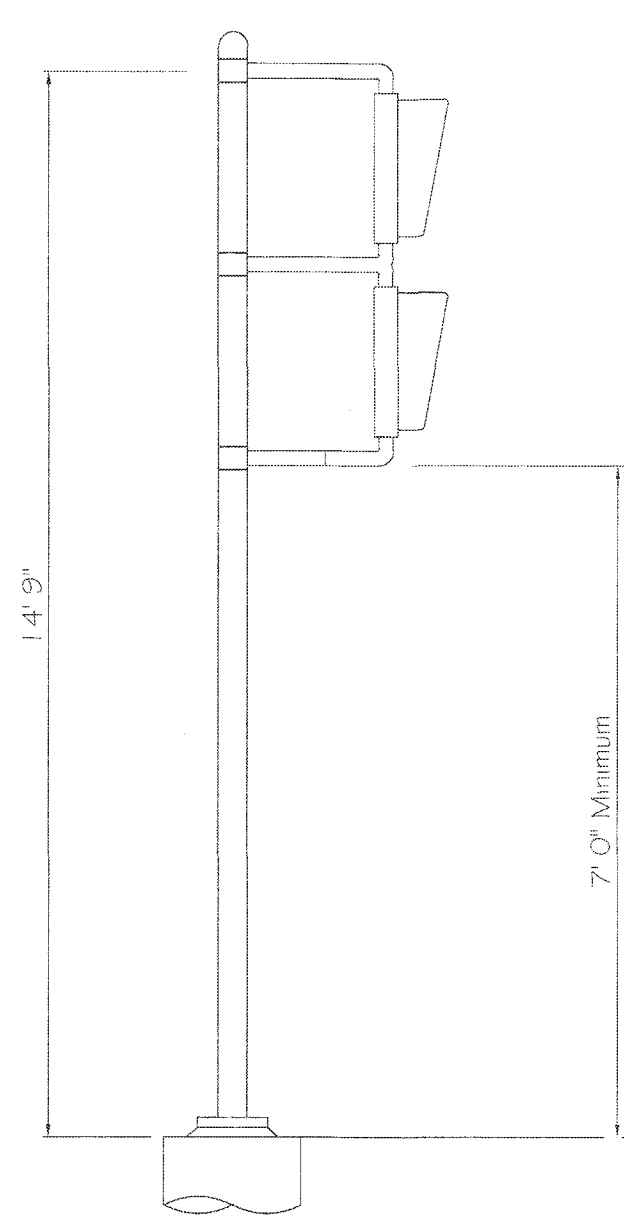

TYPE A POLE
WITH BLANKOUT SIGNS

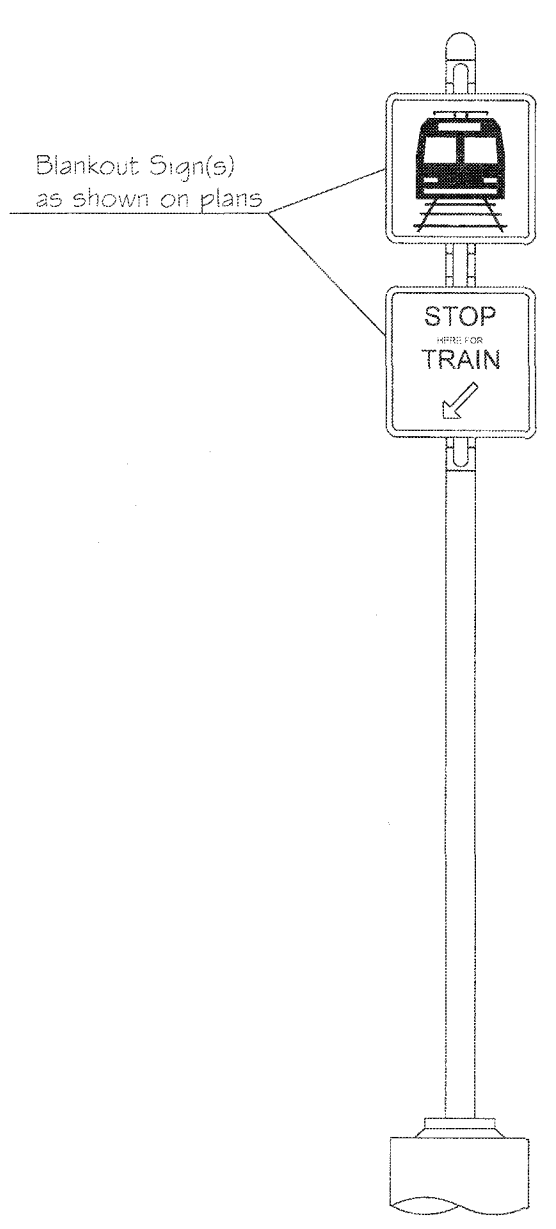

OCS POLE WITH
LRT SIGNAL, PEDESTRIAN SIGNAL
PUSHBUTTON AND SIGNS

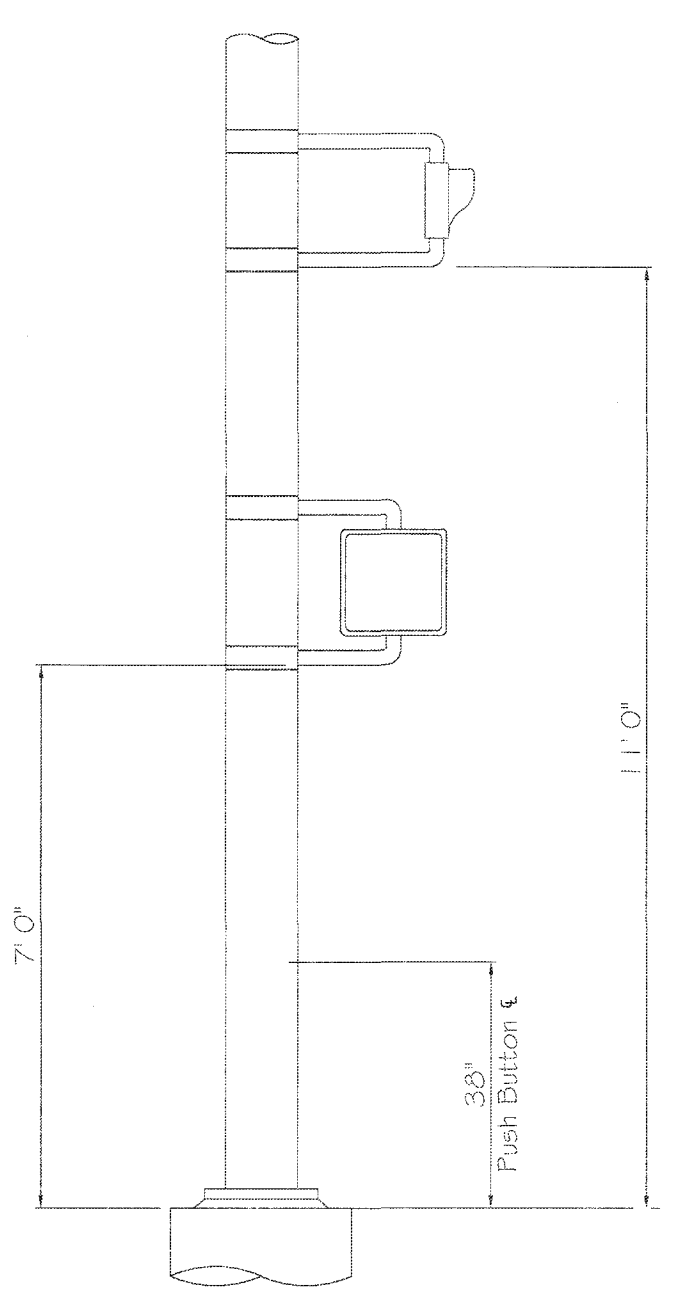

TYPE PB POLE
PEDESTRIAN PUSH BUTTON POLE

NOTES

- 1 Height measurement for Pedestrian Pushbutton is from finished grade to center of pushbutton, regardless of pushbutton style.
- 2 Height measurement for other Traffic Signal Devices are minimums. Up to a plus 6" will be acceptable.

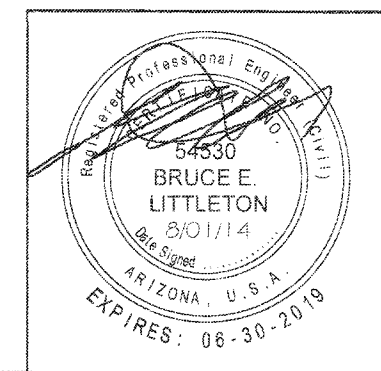
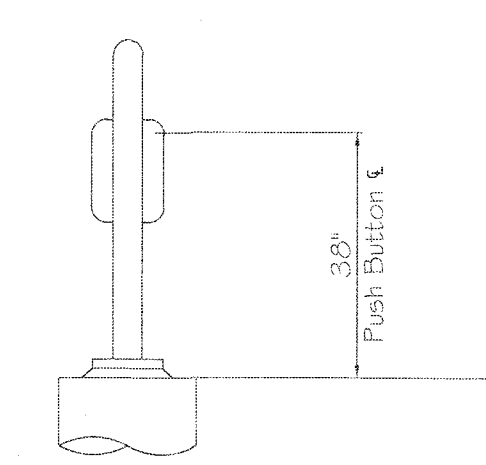

CITY OF PHOENIX, ARIZONA
STREET TRANSPORTATION DEPARTMENT
TRAFFIC SIGNAL STANDARD DETAILS

MOUNTING DETAILS
SIDE MOUNT SIGNAL EQUIPMENT

TPP File Number 10164 TS 3-1
TRAFFIC SERVICES DEPUTY DIRECTOR *Thomas J. Doolittle* 8-1-2014

TRAFFIC SIGNAL DETAILS
CITY OF PHOENIX, ARIZONA
STREET TRANSPORTATION DEPARTMENT

PROJECT #:	DR:	DES:	CK:	SHEET NO:	TOTAL SHEETS:
	DATE:	DATE:	DATE:		
	SCALE:		QS. #:		

"PER CITY OF PHOENIX CITY CODE CHAPTER 2, SECTION 2-26, THESE PLANS ARE FOR OFFICIAL USE ONLY & MAY NOT BE SHARED WITH OTHERS EXCEPT AS REQUIRED TO FULFILL THE OBLIGATIONS OF YOUR CONTRACT WITH THE CITY OF PHOENIX."

F.H.W.A. REGION	STATE	PROJ. NO.	NO.	TOTAL
9	ARIZ.			

DR: _____ DES: _____ CK: _____ DATE: _____

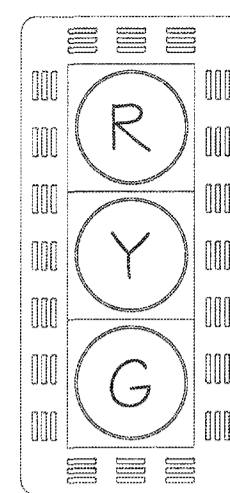

Type "F"
3 Section 12" Vehicle Signal Head
Mounted on Signal Pole

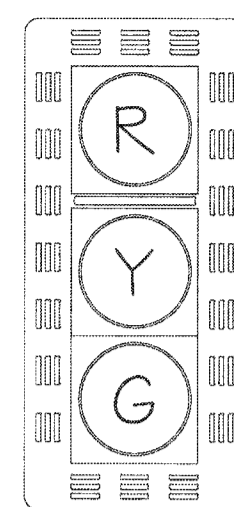

Type "F1" with Plumbizer
3 Section 12" Vehicle Signal Head
Mounted on Signal Mast Arm

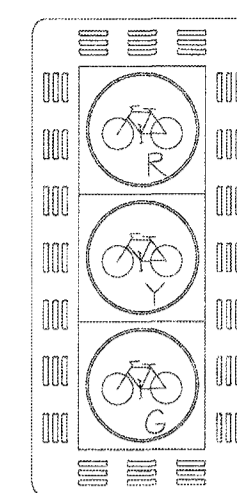

Type "B"
3 Section 12" Bike Signal Head
Mounted on Signal Pole

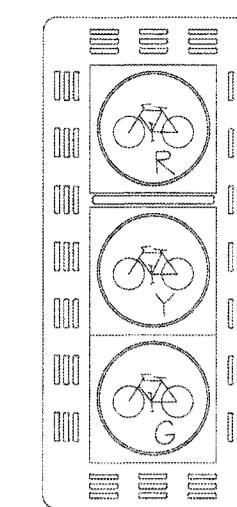

Type "B1" with Plumbizer
3 Section 12" Bike Signal Head
Mounted on Signal Mast Arm

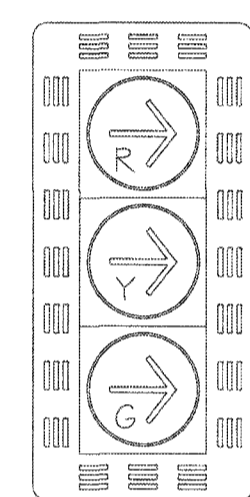

Type "R" (Right Turns)
3 Section 12" Vehicle Signal Head
with Arrows
Mounted on Signal Pole

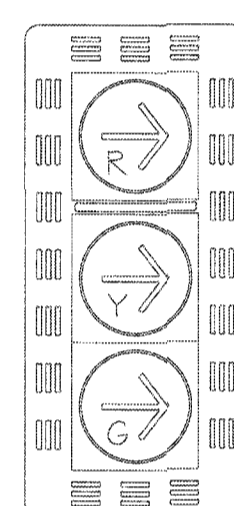

Type "R1" (Right Turns) with Plumbizer
3 Section 12" Vehicle Signal Head
with Arrows
Mounted on Signal Mast Arm

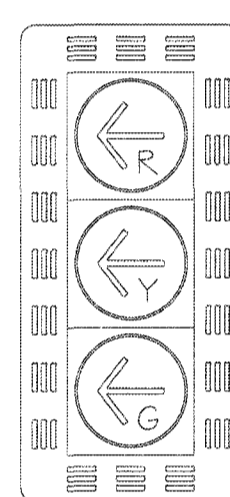

Type "R"
3 Section 12" Vehicle Signal Head
with Arrows
Mounted on Signal Pole

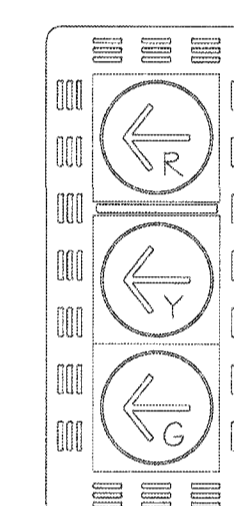

Type "R1" with Plumbizer
3 Section 12" Vehicle Signal Head
with Arrows
Mounted on Signal Mast Arm

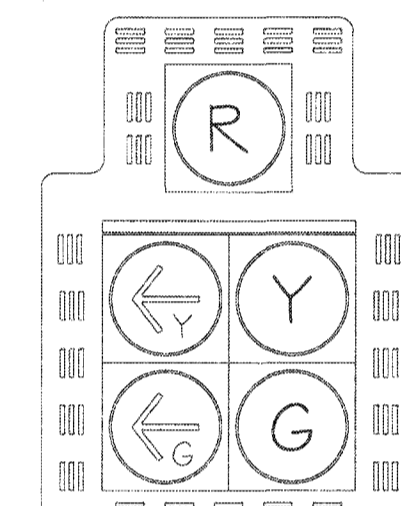

Type "Q2" with Plumbizer
5 Section 12" Signal Head
Mounted on Signal Mast arm

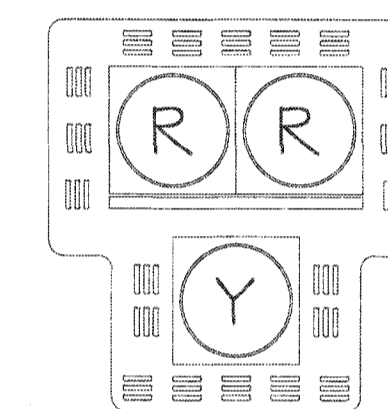

Type "T1" with Plumbizer
3 Section 12" HAWK Signal Head
Mounted on Signal Mast arm

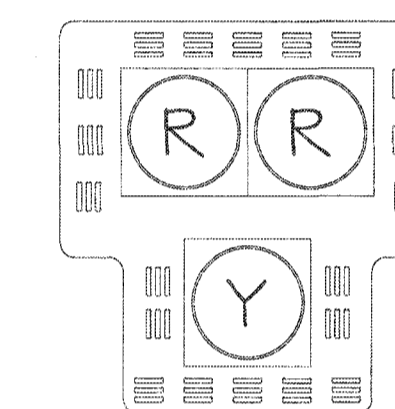

Type "T"
3 Section 12" HAWK Signal Head
Mounted on Signal Pole

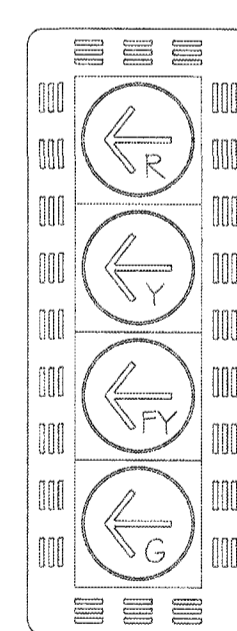

Type "FA"
4 Section 12" Signal Head
Mounted on Signal Pole
FLASHING YELLOW

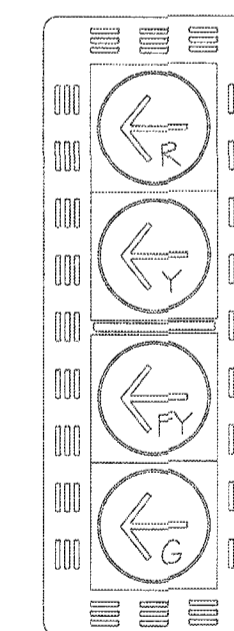

Type "FA1" with Plumbizer
4 Section 12" Signal Head
Mounted on Signal Mast Arm
FLASHING YELLOW

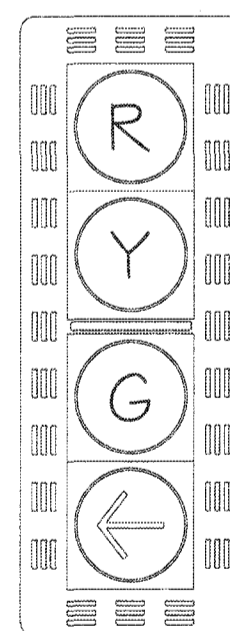

Type "G"
4 Section 12" Signal Head
Mounted on Signal Pole

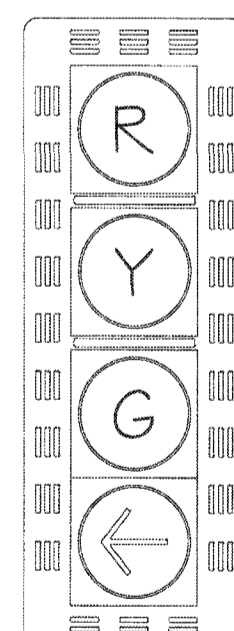

Type "G1" with Plumbizer
4 Section 12" Signal Head
Mounted on Signal Mast Arm

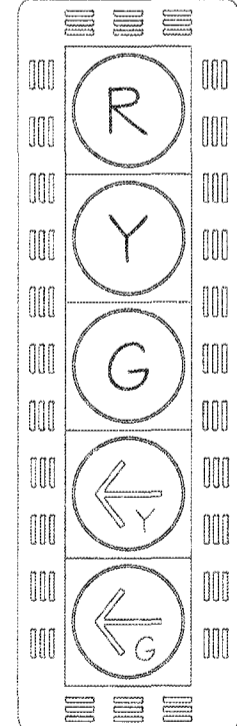

Type "Q"
5 Section 12" Vehicle Signal Head
Mounted on Signal Pole

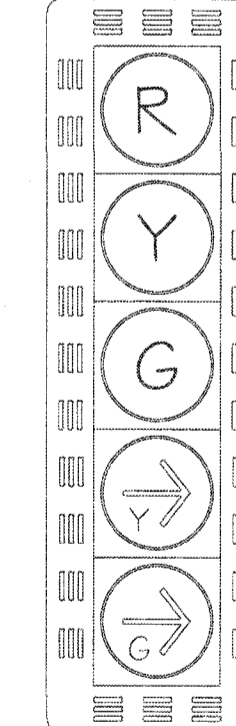

Type "Q" (Right Turns)
5 Section 12" Vehicle Signal Head
Mounted on Signal Pole

"PER CITY OF PHOENIX CITY CODE CHAPTER 2, SECTION 2-26, THESE PLANS ARE FOR OFFICIAL USE ONLY & MAY NOT BE SHARED WITH OTHERS EXCEPT AS REQUIRED TO FULFILL THE OBLIGATIONS OF YOUR CONTRACT WITH THE CITY OF PHOENIX."

CITY OF PHOENIX, ARIZONA
STREET TRANSPORTATION DEPARTMENT
TRAFFIC SIGNAL STANDARD DETAILS

TRAFFIC SIGNAL DETAILS
CITY OF PHOENIX, ARIZONA
STREET TRANSPORTATION DEPARTMENT

TRAFFIC SIGNAL HEAD
GRAPHIC DETAIL

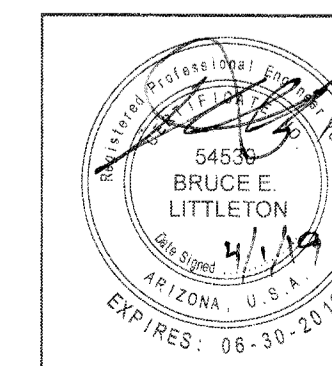

TPP File Number 10164
TS 3-2
DATE: 4-1-2019
TRAFFIC SERVICES DEPUTY DIRECTOR

PROJECT #:	DR:	DES:	CK:	SHEET NO:	TOTAL SHEETS:
	DATE:	DATE:	DATE:		
SCALE:	QS. #:				

- GENERAL NOTES**
- All IMSA Cable shall be pulled continuous (no splicing) from the Terminal Compartment in each Signal Head or Push Button Station to the Hand Hole at the base of Pole.
 - Cable shall be utilized as follows:
 3 Conductor - All ADA Push Button Stations
 Luminaires, Illuminated Street Signs, Detection Cameras
 5 Conductor - All 3 Section, 4 Section Signal Heads, HAWK Signal Heads, Pedestrian Heads, Audible pushbutton Stations
 7 Conductor - All outside Mast Arm and Type Q Signal Heads
 - Orange (North or East) or blue (South or West) Tape shall be applied six (6) inches above PVC bell end or IMSA Cable Jacket in Junction Box.
 - All Cable shall be tagged in the Hand Hole with orange (North or East) or blue (South or West) tape as follows:

MAST ARM VEHICLE INDICATIONS		
HEAD	CONDUCTORS	TAPES*
On Pole	5	1
First on Mast Arm	5	2
Next Outside	5	3
Next Outside	5	4
End of Mast Arm	7	5*

* Band Number corresponds to Head Number

- IMSA Cables for Pedestrian Heads shall be identified in Hand Hole using Brown tape in addition to color of phase.
- IMSA Cable for Luminaires shall be run continuous to Junction Box and identified with one (1) band of purple tape.
- IMSA Cable for Illuminated Street Signs shall be run continuous to Junction Box and identified with two (2) bands of purple tape.
- IMSA Power Cable for wireless Radio shall be pulled continuous from radio to dedicated circuit in Power Service Pedestal when available. Connect to luminaire circuit in junction box at base of pole when PSP is not available. Identified cable in junction boxes with three (3) bands of purple tape.
- CAT 5e Cable shall be pulled continuous from Wireless Radio to inside the Controller Cabinet.
- CCTV Cable and Video Detection Cable shall be pulled continuous from the device to inside the Controller Cabinet.
- All IMSA Cable to be #16 AWG Stranded unless otherwise noted on approved signal plans. When terminating in Signal Heads use suitable manufactured crimp on connector of appropriate size.

HAWK SIGNAL HEAD			COMMUNICATION RADIO			LUMINAIRE (FROM LUMINAIRE)			7 CONDUCTOR HAWK ONLY	
5 CONDUCTOR CABLE			3 CONDUCTOR CABLE			3 CONDUCTOR CABLE			INSULATION COLOR	SIGNAL INTERVAL
NO.	COLOR	FUNCTION	NO.	BASIC COLOR	FUNCTION	NO.	BASIC COLOR	FUNCTION		
1	Black	Left Red Signal	1	Black	Load	1	Black	Load	Black	Left Red Signal
2	White		2	White	Neutral	2	White	Neutral	Red	Right Red Signal
3	Red	Right Red Signal	3	Green	Ground	3	Green	Ground	Orange	Yellow
4	Green								Blue	Don't Walk
5	Orange	Yellow							Green	Walk
									White Black	Push Button
									White	Push Button Common

ADA PUSH BUTTON			PEDESTRIAN HEAD		
3 CONDUCTOR CABLE			5 CONDUCTOR CABLE		
NO.	BASIC COLOR	PUSH BUTTON STATION	NO.	BASIC COLOR	SIGNAL INTERVAL
1	Black	Push Button	1	Black	Don't Walk
2	White	Push Button Common	2	White	Pedestrian Common
3	Green	Spare	3	Red	Spare
			4	Green	Walk
			5	Orange	Spare

F.H.W.A. REGION	STATE	PROJ. NO.	NO.	TOTAL
9	ARIZ.			

DR: _____ DES: _____ CK: _____ DATE: _____

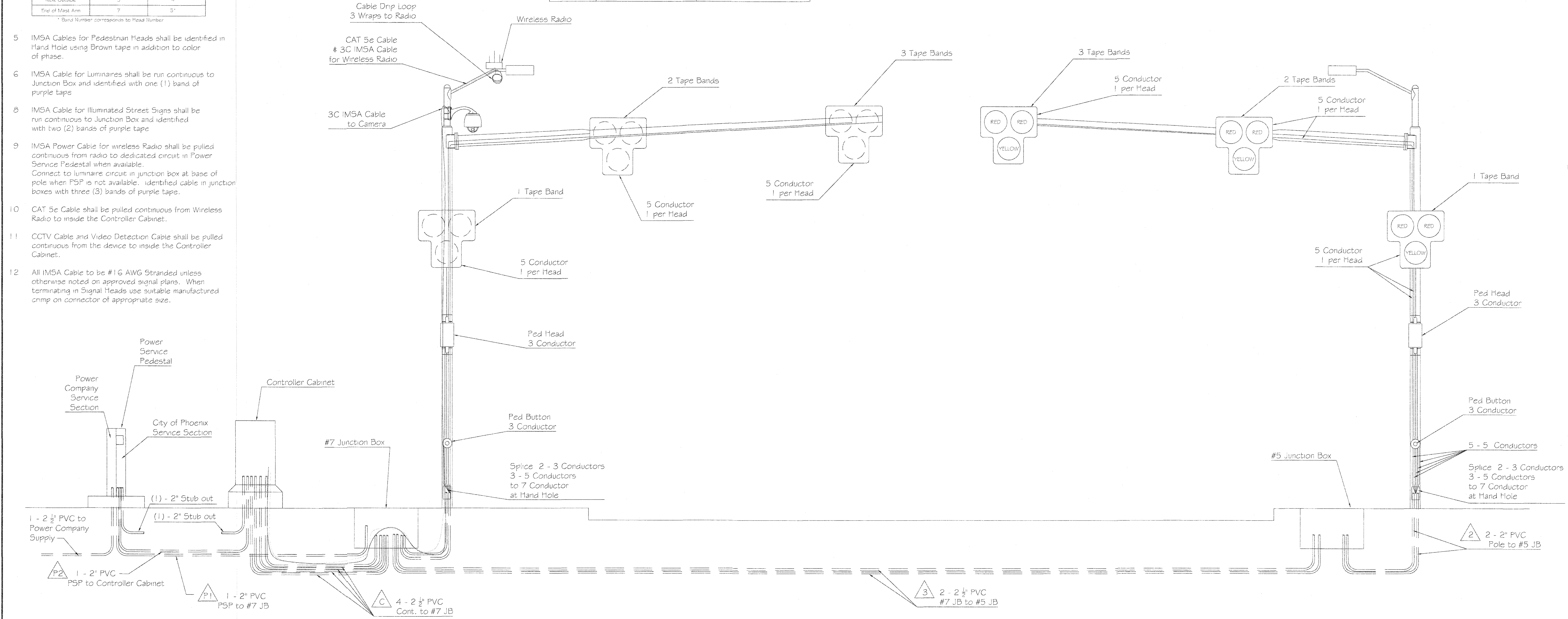

High Intensity Activated CrossWalk (HAWK) Schematic - Dual Mast Arm

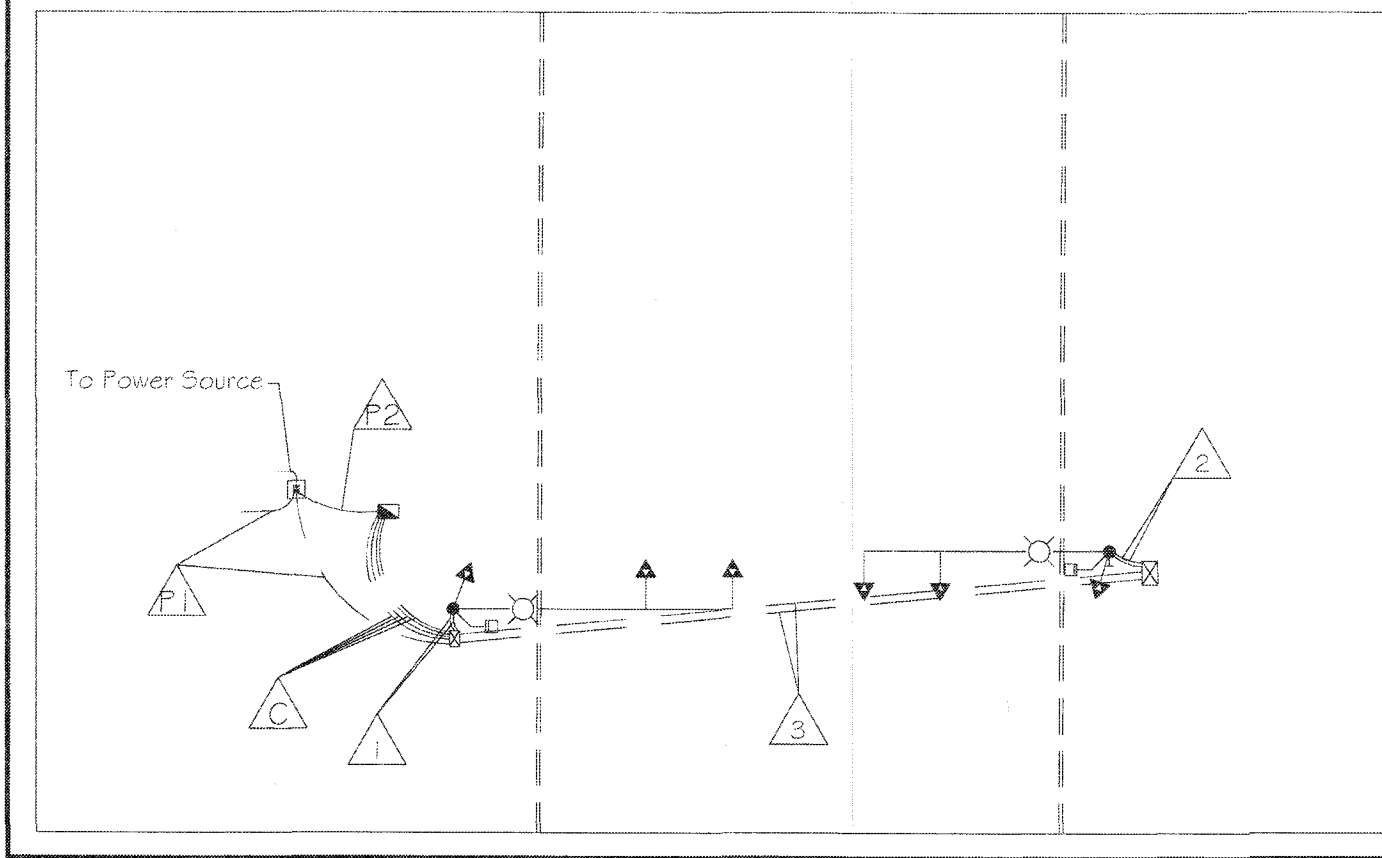

C Controller to #7 Junction Box						P1 Power Service Pedestal to #7 Junction Box		P2 Power Service Pedestal to Controller
CONDUIT 1	CONDUIT 2	CONDUIT 3	CONDUIT 4	CONDUIT 5 to PSP	CONDUIT 6 Stub-Out	CONDUIT 1	CONDUIT 2	CONDUIT 3
#10 Bare Copper #10 AWG White 7C IMSA Cable	#10 Bare Copper 175 Cable	#10 Bare Copper #10 AWG Black #10 AWG White #10 AWG Green	Detectable Mule Tape	#10 Bare Copper #10 AWG Black #10 AWG White #10 AWG Green	Detectable Mule Tape	#10 Bare Copper 3C IMSA Cable 3C Radio 3C Luminaire	Stub-Out	#10 Bare Copper #10 AWG Black #10 AWG White #10 AWG Green 5C IMSA Cable

1 #7 Junction Box to Mast Arm Pole		2 #5 Junction Box to Mast Arm Pole		3 Junction Box to Junction Box	
CONDUIT 1	CONDUIT 2	CONDUIT 1	CONDUIT 2	CONDUIT 1	CONDUIT 2
#10 Bare Copper #10 AWG White	Detectable Mule Tape	#10 Bare Copper #10 AWG White 5C IMSA Cable 7C IMSA Cable N or S 7C IMSA Cable S or W	Detectable Mule Tape	#10 Bare Copper #10 AWG White 5C IMSA Cable 7C IMSA Cable S or N 7C IMSA Cable W or S	Detectable Mule Tape

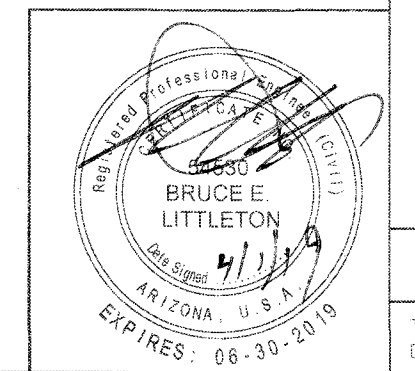

CITY OF PHOENIX, ARIZONA
 STREET TRANSPORTATION DEPARTMENT
 TRAFFIC SIGNAL STANDARD DETAILS

TYPICAL HAWK
 PEDESTRIAN CROSSING BEACON
 DUAL MAST ARM

TPP File Number 10164 TS 3-3
 DATE: 4-1-2019

TRAFFIC SIGNAL DETAILS
 CITY OF PHOENIX, ARIZONA
 STREET TRANSPORTATION DEPARTMENT

PROJECT #:
 DR: _____ DES: _____ CK: _____ DATE: _____
 SHEET NO: _____ TOTAL SHEETS: _____
 SCALE: _____ Q5. #: _____

- GENERAL NOTES**
- All IMSA Cable shall be pulled continuous (no splicing) from the Terminal Compartment in each Signal Head or Push Button Station to the Hand Hole at the base of Pole.
 - Cable shall be utilized as follows:
 3 Conductor - All ADA Push Button Stations
 Luminaires: Illuminated Street Signs, Detection Cameras
 5 Conductor - All 3 Section, 4 Section Signal Heads, HAWK Signal Heads, Pedestrian Heads, Audible pushbutton Stations
 7 Conductor - All outside Mast Arm and Type Q Signal Heads
 - Orange (North or East) or blue (South or West) Tape shall be applied six (6) inches above PVC bell end on IMSA Cable Jacket in Junction Box.
 - All Cable shall be tagged in the Hand Hole with orange (North or East) or blue (South or West) tape as follows:

MAST ARM VEHICLE INDICATIONS		
HEAD	CONDUCTORS	TAPES
On Pole	5	1
First on Mast Arm	5	2
Next Outside	5	3
Next Outside	5	4
End of Mast Arm	7	5*

*Bare Number corresponds to Head Number

- IMSA Cables for Pedestrian Heads shall be identified in Hand Hole using Brown tape in addition to color of phase.
- IMSA Cable for Luminaires shall be run continuous to Junction Box and identified with one (1) band of purple tape.
- IMSA Cable for Illuminated Street Signs shall be run continuous to Junction Box and identified with two (2) bands of purple tape.
- IMSA Power Cable for wireless Radio shall be pulled continuous from radio to dedicated circuit in Power Service Pedestal when available. Connect to luminaire circuit in junction box at base of pole when PSP is not available. Identified cable in junction boxes with three (3) bands of purple tape.
- CAT 5e Cable shall be pulled continuous from Wireless Radio to inside the Controller Cabinet.
- CCTV Cable and Video Detection Cable shall be pulled continuous from the device to inside the Controller Cabinet.
- All IMSA Cable to be #16 AWG Stranded unless otherwise noted on approved signal plans. When terminating in Signal Heads use suitable manufactured crimp on connector of appropriate size.
- See sheet TS3-5 for variations of pole configuration based on project.

HAWK SIGNAL HEAD			COMMUNICATION RADIO			LUMINAIRE (FROM LUMINAIRE)			7 CONDUCTOR HAWK ONLY	
5 CONDUCTOR CABLE			3 CONDUCTOR CABLE			3 CONDUCTOR CABLE			INSULATION COLOR	SIGNAL INTERVAL
NO.	COLOR	FUNCTION	NO.	BASIC COLOR	FUNCTION	NO.	BASIC COLOR	FUNCTION		
1	Black	Left Red Signal	1	Black	Load	1	Black	Load	Black	Left Red Signal
2	White		2	White	Neutral	2	White	Neutral	Red	Right Red Signal
3	Red	Right Red Signal	3	Green	Ground	3	Green	Ground	Orange	Yellow
4	Green								Blue	Don't Walk
5	Orange	Yellow							Green	Walk
									White Black	Push Button
									White	Push Button Common

F.H.W.A. REGION	STATE	PROJ. NO.	NO.	TOTAL
9	ARIZ.			

DR: _____ DES: _____ CK: _____ DATE: _____

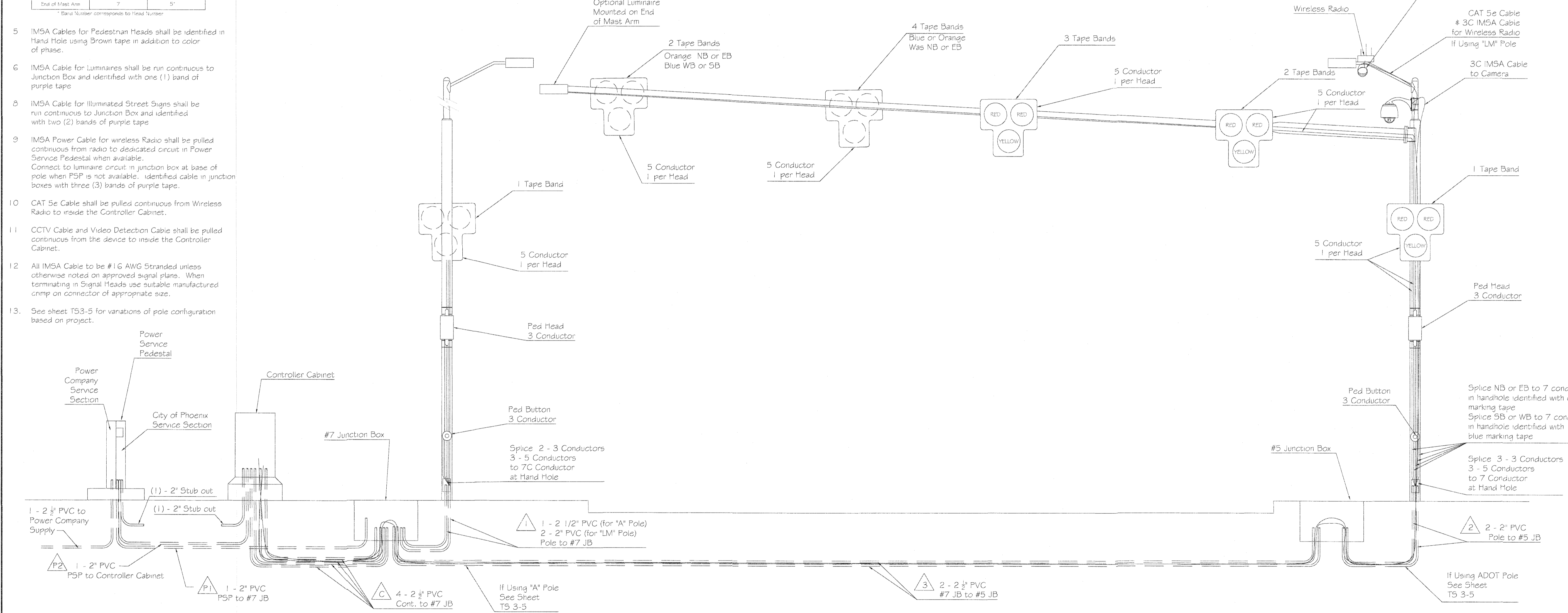

High Intensity Activated CrossWalk (HAWK) Schematic - Single Mast Arm

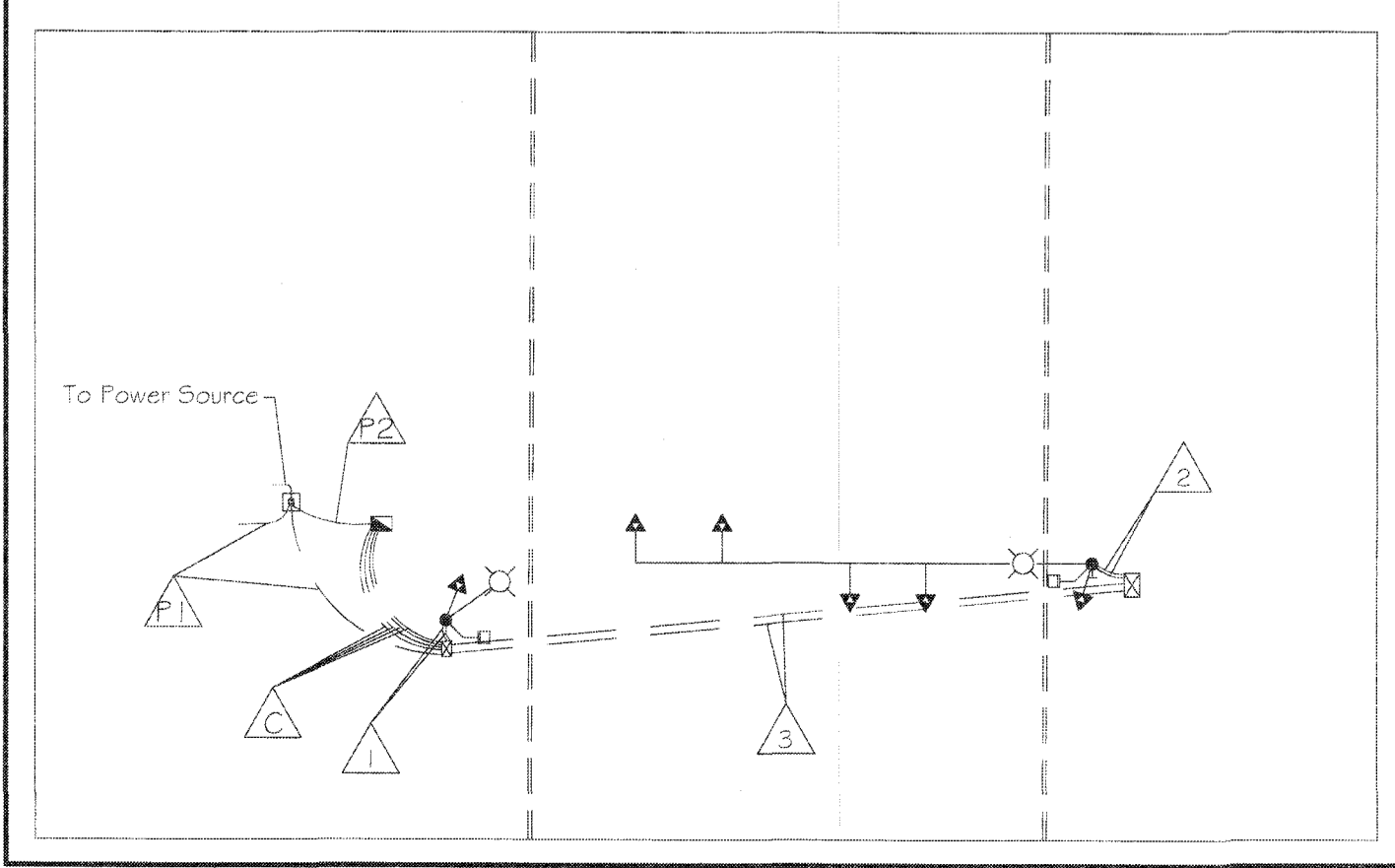

C Controller to #7 Junction Box						P1 Power Service Pedestal to #7 Junction Box		P2 Power Service Pedestal to Controller
CONDUIT 1	CONDUIT 2	CONDUIT 3	CONDUIT 4	CONDUIT 5 to PSP	CONDUIT 6 Stub Out	CONDUIT 1	CONDUIT 2	CONDUIT 3
#10 Bare Copper #10 AWG White 7C IMSA Cable	#10 Bare Copper ITS Cable	#10 Bare Copper #10 AWG Black #10 AWG White #10 AWG Green	Detectable Mule Tape	#10 Bare Copper #10 AWG Black #10 AWG White #10 AWG Green	Detectable Mule Tape	#10 Bare Copper Stub Out		#10 Bare Copper #10 AWG Black #10 AWG White #10 AWG Green 5C IMSA Cable

1 #7 Junction Box to Mast Arm Pole		2 #5 Junction Box to Mast Arm Pole		3 Junction Box to Junction Box	
CONDUIT 1	CONDUIT 2	CONDUIT 1	CONDUIT 2	CONDUIT 1	CONDUIT 2
#10 Bare Copper #10 AWG White	Detectable Mule Tape	#10 Bare Copper #10 AWG White 5C IMSA Cable 7C IMSA Cable N or E 7C IMSA Cable S or W	Detectable Mule Tape	#10 Bare Copper #10 AWG White 5C IMSA Cable 7C IMSA Cable E or N 7C IMSA Cable W or S	Detectable Mule Tape

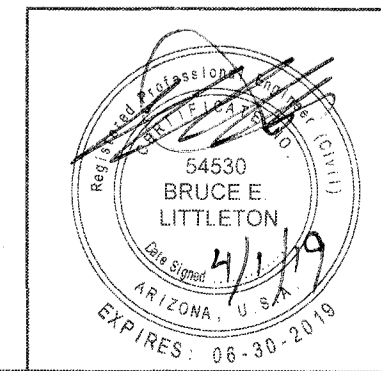

CITY OF PHOENIX, ARIZONA
 STREET TRANSPORTATION DEPARTMENT
 TRAFFIC SIGNAL STANDARD DETAILS

TYPICAL HAWK
 PEDESTRIAN CROSSING BEACON
 SINGLE MAST ARM

TPP File Number 10164
 TS 3-4
 4-1-2019

TRAFFIC SIGNAL DETAILS
 CITY OF PHOENIX, ARIZONA
 STREET TRANSPORTATION DEPARTMENT

PROJECT #:
 DR: _____ DES: _____ CK: _____ SHEET NO: _____ TOTAL SHEETS: _____
 DATE: _____ DATE: _____ DATE: _____
 SCALE: _____ QS #:

GENERAL NOTES

- All IMSA Cable shall be pulled continuous (no splicing) from the Terminal Compartment in each Signal Head or Push Button Station to the Hand Hole at the base of Pole
- Cable shall be utilized as follows:
 - 3 Conductor - All ADA Push Button Stations
Luminaires, Illuminated Street Signs, Detection Cameras
 - 5 Conductor - All 3 Section, 4 Section Signal Heads, HAWK Signal Heads, Pedestrian Heads, Audible pushbuttons Stations
 - 7 Conductor - All outside Mast Arm and Type Q Signal Heads
- Orange (North or East) or blue (South or West) Tape shall be applied six (6) inches above PVC bell end on IMSA Cable Jacket in Junction Box
- All Cable shall be tagged in the Hand Hole with orange (North or East) or blue (South or West) tape as follows;

MAST ARM VEHICLE INDICATIONS		
HEAD	CONDUCTORS	TAPE(S)
On Pole	3	1
First on Mast Arm	5	2
Next Outside	5	3
Next Outside	5	4
End of Mast Arm	7	5*

* Band Number corresponds to Head Number

- IMSA Cables for Pedestrian Heads shall be identified in Hand Hole using Brown tape in addition to color of phase.
- IMSA Cable for Luminaires shall be run continuous to Junction Box and identified with one (1) band of purple tape
- IMSA Cable for Illuminated Street Signs shall be run continuous to Junction Box and identified with two (2) bands of purple tape
- IMSA Power Cable for wireless Radio shall be pulled continuous from radio to dedicated circuit in Power Service Pedestal when available. Connect to luminaire circuit in junction box at base of pole when PSP is not available. Identified cable in junction boxes with three (3) bands of purple tape.
- CAT 5e Cable shall be pulled continuous from Wireless Radio to inside the Controller Cabinet.
- CCTV Cable and Video Detection Cable shall be pulled continuous from the device to inside the Controller Cabinet.
- All IMSA Cable to be # 16 AWG Stranded unless otherwise noted on approved signal plans. When terminating in Signal Heads use suitable manufactured crimp on connector of appropriate size.

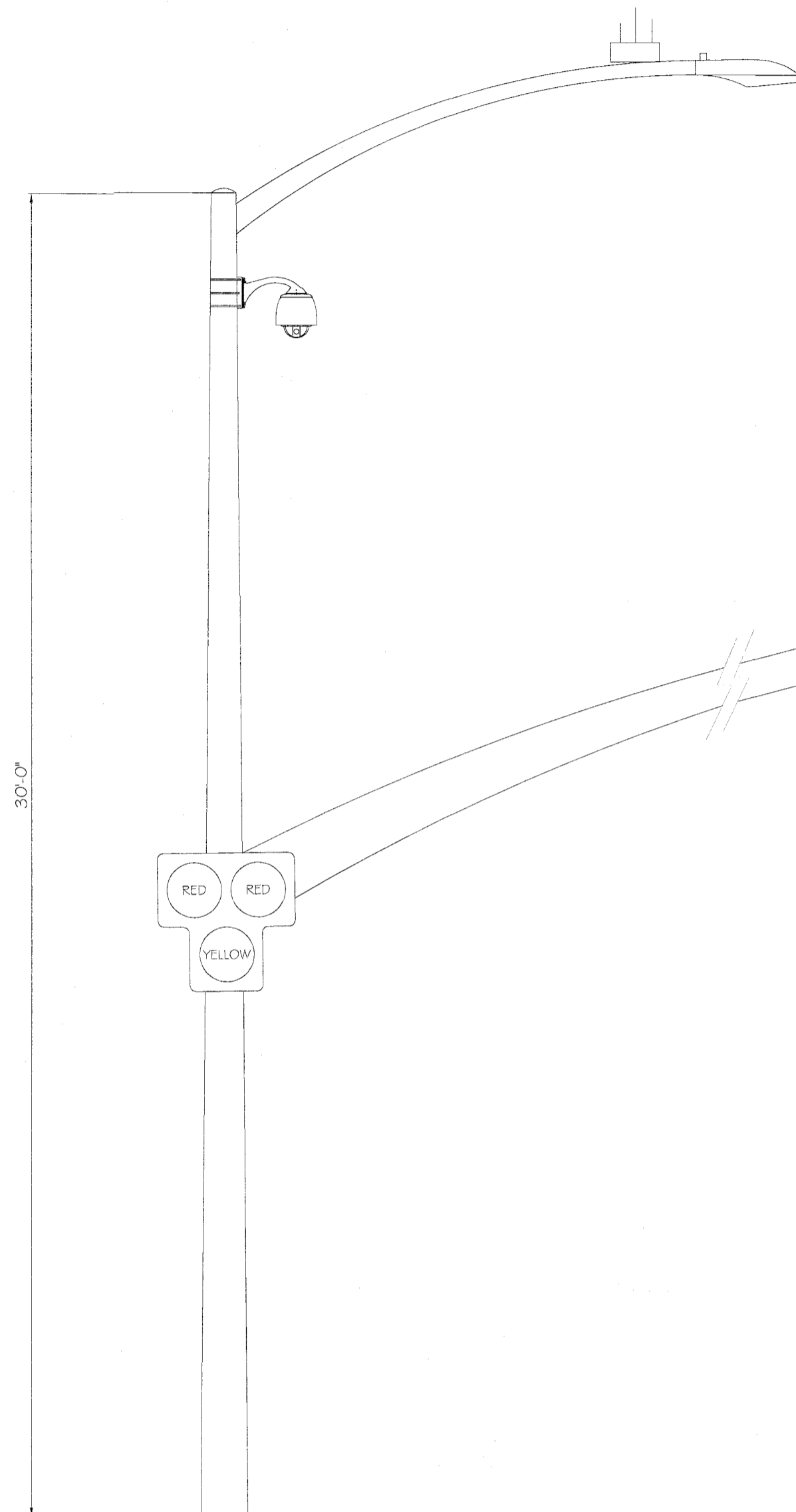

ADOT Pole Configuration
Typical For "Q" "R" "W"

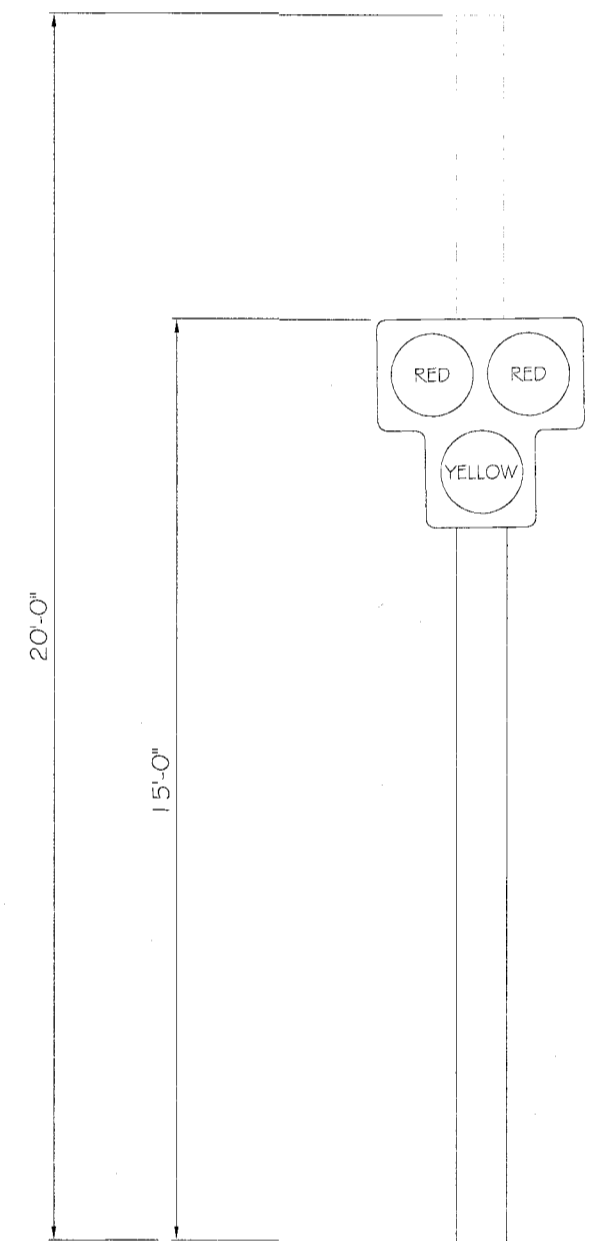

15' or 20' "A" Pole Configuration

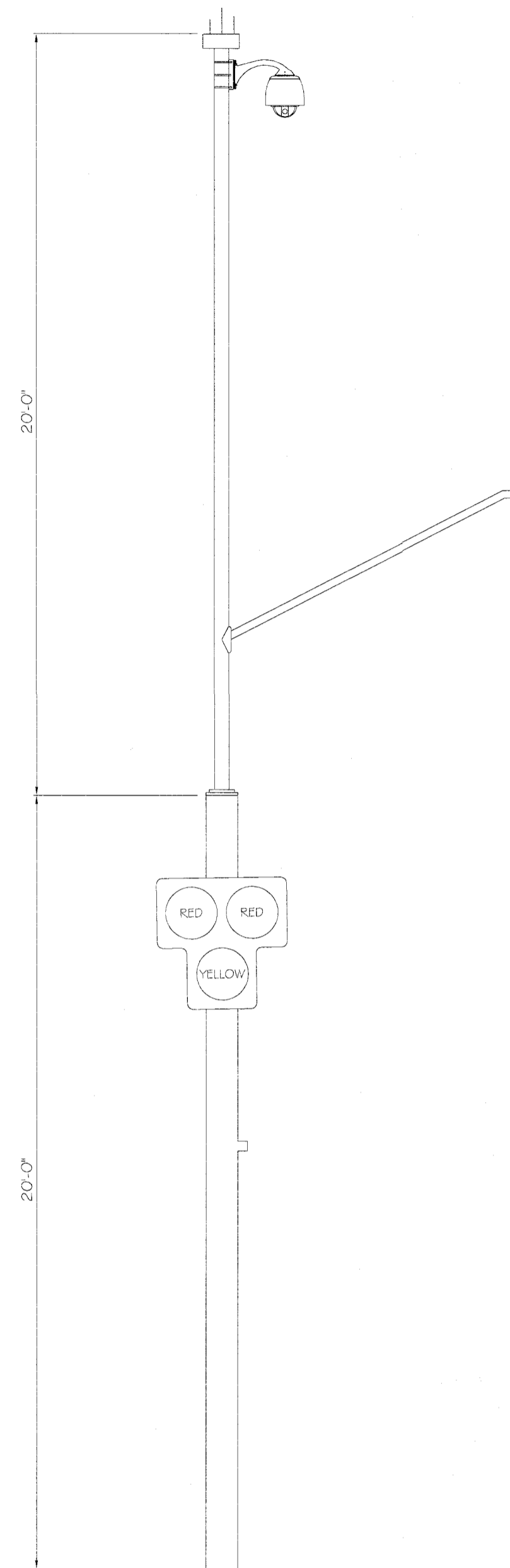

"LM" Pole Configuration

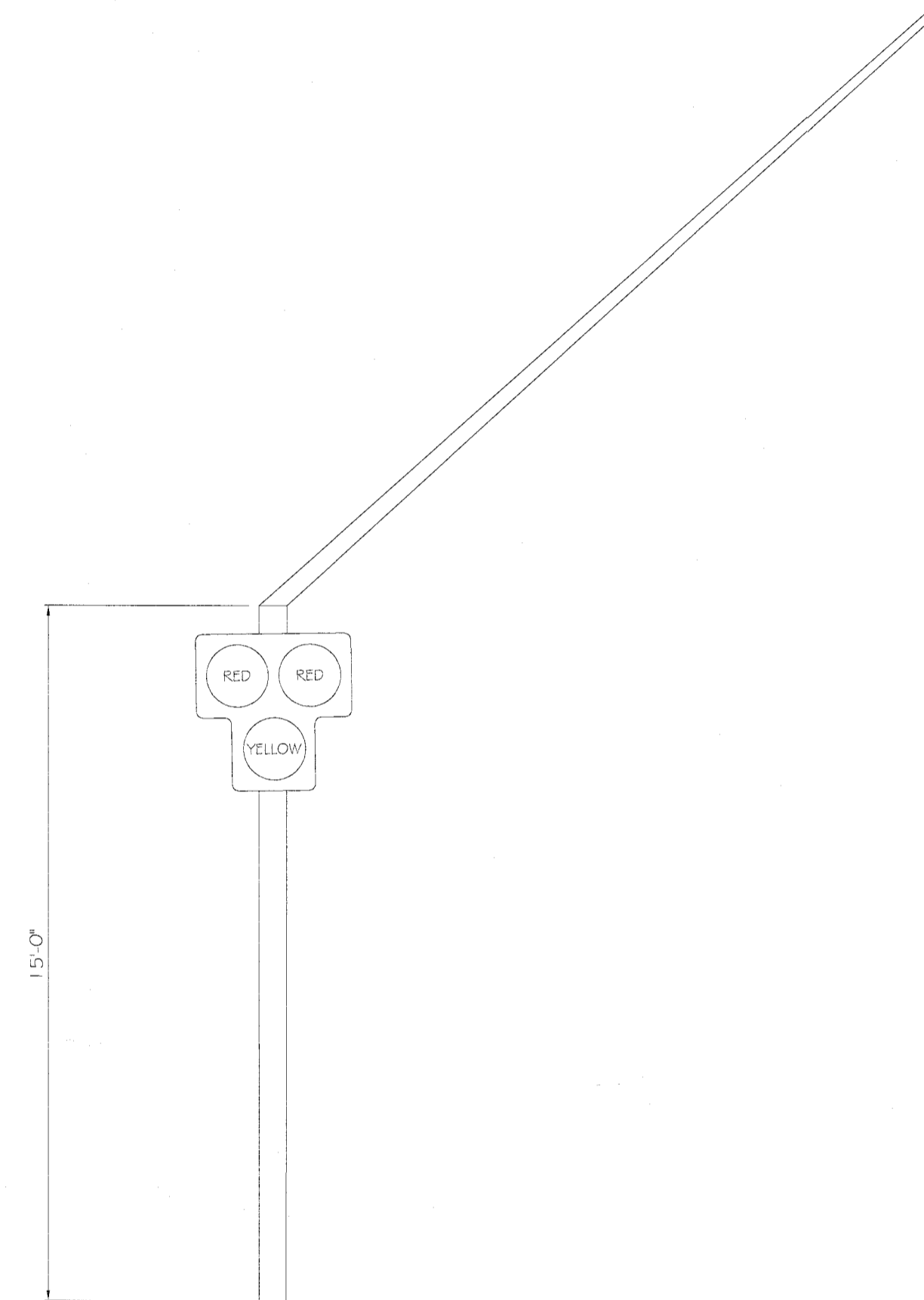

"G" Pole Configuration

F.H.W.A. REGION	STATE	PROJ. NO.	NO.	TOTAL
9	ARIZ.			

DR: DES: CK: DATE:

PER CITY OF PHOENIX CITY CODE CHAPTER 2, SECTION 2-28, THESE PLANS ARE FOR OFFICIAL USE ONLY & MAY NOT BE SHARED WITH OTHERS EXCEPT AS REQUIRED TO FULFILL THE OBLIGATIONS OF YOUR CONTRACT WITH THE CITY OF PHOENIX.

TRAFFIC SIGNAL DETAILS
CITY OF PHOENIX, ARIZONA
STREET TRANSPORTATION DEPARTMENT

CITY OF PHOENIX, ARIZONA
STREET TRANSPORTATION DEPARTMENT
TRAFFIC SIGNAL STANDARD DETAILS

TYPICAL HAWK
PEDESTRIAN CROSSING BEACON
POLE CONFIGURATION

TPP File Number 10164 TS 3-5
4-1-2019

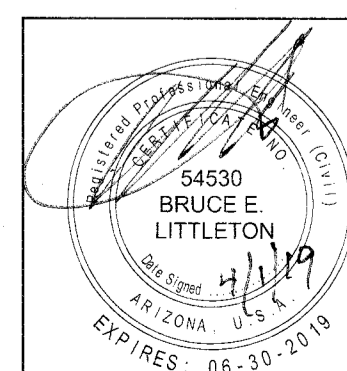

PROJECT #:	SHEET NO:	TOTAL SHEETS:
DR: DATE:	DES: DATE:	CK: DATE:
SCALE:	QS. #:	

PROJECT #:

PROJECT #:

TRAFFIC SIGNAL COLOR CODE TABLE

Table with columns: SIGNAL INDICATION, PHASE / DIRECTION, INSIDE/OUTSIDE BUNDLE COLOR, 42 CONDUCTOR CABLE, 25 CONDUCTOR CABLE, 20 CONDUCTOR CABLE. Rows include various signal types like Red Yellow Green, L/T Red Arrow, Walk Don't Walk, Ped Push Button, Spare, etc.

TYPE F SIGNAL HEADS INSIDE & SIDE MOUNT

Table for Type F Signal Heads with columns: NO., BASIC COLOR, SIGNAL INTERVAL. Rows 1-5.

OUTSIDE MAST ARM AND TYPE Q HEADS

Table for Outside Mast Arm and Type Q Heads with columns: NO., BASIC COLOR, SIGNAL INTERVAL. Rows 1-7.

4 SECTION FLASHING YELLOW ARROW MAST ARM AND SIDE MOUNT

Table for 4 Section Flashing Yellow Arrow with columns: NO., BASIC COLOR, SIGNAL INTERVAL. Rows 1-7.

LRT 2 Indication Signal

Table for LRT 2 Indication Signal with columns: NO., BASIC COLOR, INDICATION. Rows 1-7.

LRT 3 Indication Signal

Table for LRT 3 Indication Signal with columns: NO., BASIC COLOR, INDICATION. Rows 1-7.

LRT Signal 5 Conductor Head to Hand Hole

Table for LRT Signal 5 Conductor Head to Hand Hole with columns: NO., BASIC COLOR, INDICATION. Rows 1-5. Includes notes.

120V ILLUMINATED STREET SIGN AND LUMINAIRE

Table for 120V Illuminated Street Sign with columns: NO., COLOR, FUNCTION. Rows 1-5.

240V ILLUMINATED STREET SIGN AND LUMINAIRE

Table for 240V Illuminated Street Sign with columns: NO., COLOR, FUNCTION. Rows 1-5.

LUMINAIRE (FROM LUMINAIRE)

Table for Luminaire (from Luminaire) with columns: NO., BASIC COLOR, FUNCTION. Rows 1-3.

ILLUMINATED STREET SIGN (FROM SIGN)

Table for Illuminated Street Sign (from Sign) with columns: NO., BASIC COLOR, FUNCTION. Rows 1-3.

ADA PUSH BUTTON

Table for ADA Push Button with columns: NO., BASIC COLOR, PUSH BUTTON STATION. Rows 1-3.

PEDESTRIAN HEAD

Table for Pedestrian Head with columns: NO., BASIC COLOR, SIGNAL INTERVAL. Rows 1-5.

COMMUNICATION RADIO

Table for Communication Radio with columns: NO., BASIC COLOR, FUNCTION. Rows 1-3.

BLANK OUT SIGN

Table for Blank Out Sign with columns: NO., COLOR, FUNCTION. Rows 1-5. Includes note: * Where second function is required.

Header table with columns: F.H.W.A. REGION, STATE, PROJ. NO., NO., TOTAL. Values: 9, ARIZ., , , .

GENERAL NOTES

- 1 All IMSA Cable shall be pulled continuous (no splicing) from the Terminal Compartment in each Signal Head or Push Button Station to the Hand Hole at the base of Pole
2 Cable shall be utilized as follows:
3 Conductor - All ADA Push Button Stations, Luminaires, Illuminated Street Signs, Detection Cameras
5 Conductor - All 3 Section, 4 Section Signal Heads, HAWK Signal Heads, Pedestrian Heads, Audible pushbutton Stations
7 Conductor - All outside Mast Arm and Type Q Signal Heads
3 Orange (North or East) or blue (South or West) Tape shall be applied six (6) inches above PVC bell end on IMSA Cable Jacket in Junction Box
4 All Cable shall be tagged in the Hand Hole with orange (North or East) or blue (South or West) tape as follows:

Table: MAST ARM VEHICLE INDICATIONS. Columns: HEAD, CONDUCTORS, TAPES. Rows: On Pole, First on Mast Arm, Next Outlets, Next Outlets, End of Mast Arm.

- 5 IMSA Cables for Pedestrian Heads shall be identified in Hand Hole using Brown tape in addition to color of phase.
6 IMSA Cable for Luminaires shall be run continuous to Junction Box and identified with one (1) band of purple tape
8 IMSA Cable for Illuminated Street Signs shall be run continuous to Junction Box and identified with two (2) bands of purple tape
9 IMSA Power Cable for wireless Radio shall be pulled continuous from radio to dedicated circuit in Power Service Pedestal when available. Connect to luminaire circuit in junction box at base of pole when P5P is not available. Identified cable in junction boxes with three (3) bands of purple tape.
10 CAT 5e Cable shall be pulled continuous from Wireless Radio to inside the Controller Cabinet.
11 CCTV Cable and Video Detection Cable shall be pulled continuous from the device to inside the Controller Cabinet.
12 All IMSA Cable to be #16 AWG Stranded unless otherwise noted on approved signal plans. When terminating in Signal Heads use suitable manufactured crimp on connector of appropriate size.

TRAFFIC SIGNAL DETAILS CITY OF PHOENIX, ARIZONA STREET TRANSPORTATION DEPARTMENT

CITY OF PHOENIX, ARIZONA STREET TRANSPORTATION DEPARTMENT TRAFFIC SIGNAL STANDARD DETAILS

WIRE CODE TABLES

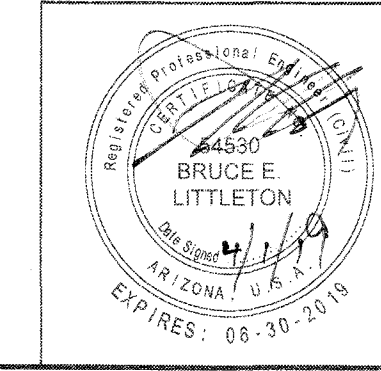

TPP File Number: 10164 TS 4-1 DATE: 4-1-2019

Table with columns: PROJECT #, DR., DES., CK., DATE, SHEET NO., TOTAL SHEETS. Values: , , , , , , .

OUTSIDE BUNDLE MARKED WITH ORANGE TAPE

INSIDE BUNDLE MARKED WITH BLUE TAPE

PER CITY OF PHOENIX CITY CODE CHAPTER 2, SECTION 2-26, THESE PLANS ARE FOR OFFICIAL USE ONLY & MAY NOT BE SHARED WITH OTHERS EXCEPT AS REQUIRED TO FULFILL THE OBLIGATIONS OF YOUR CONTRACT WITH THE CITY OF PHOENIX.

F.H.W.A. REGION	STATE	PROJ. NO.	NO.	TOTAL
9	ARIZ.			

DR:	DES:	CK:	DATE:
-----	------	-----	-------

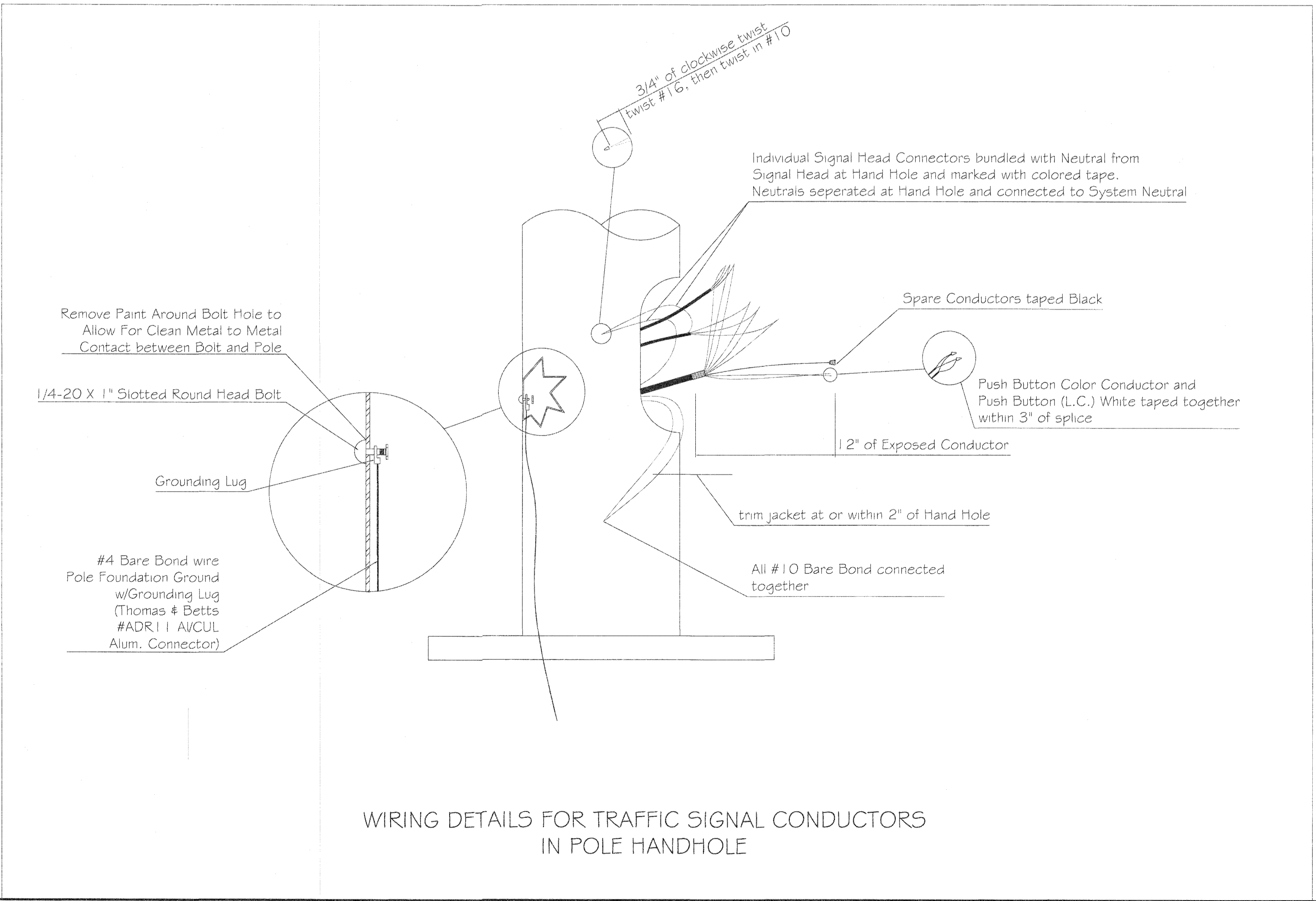
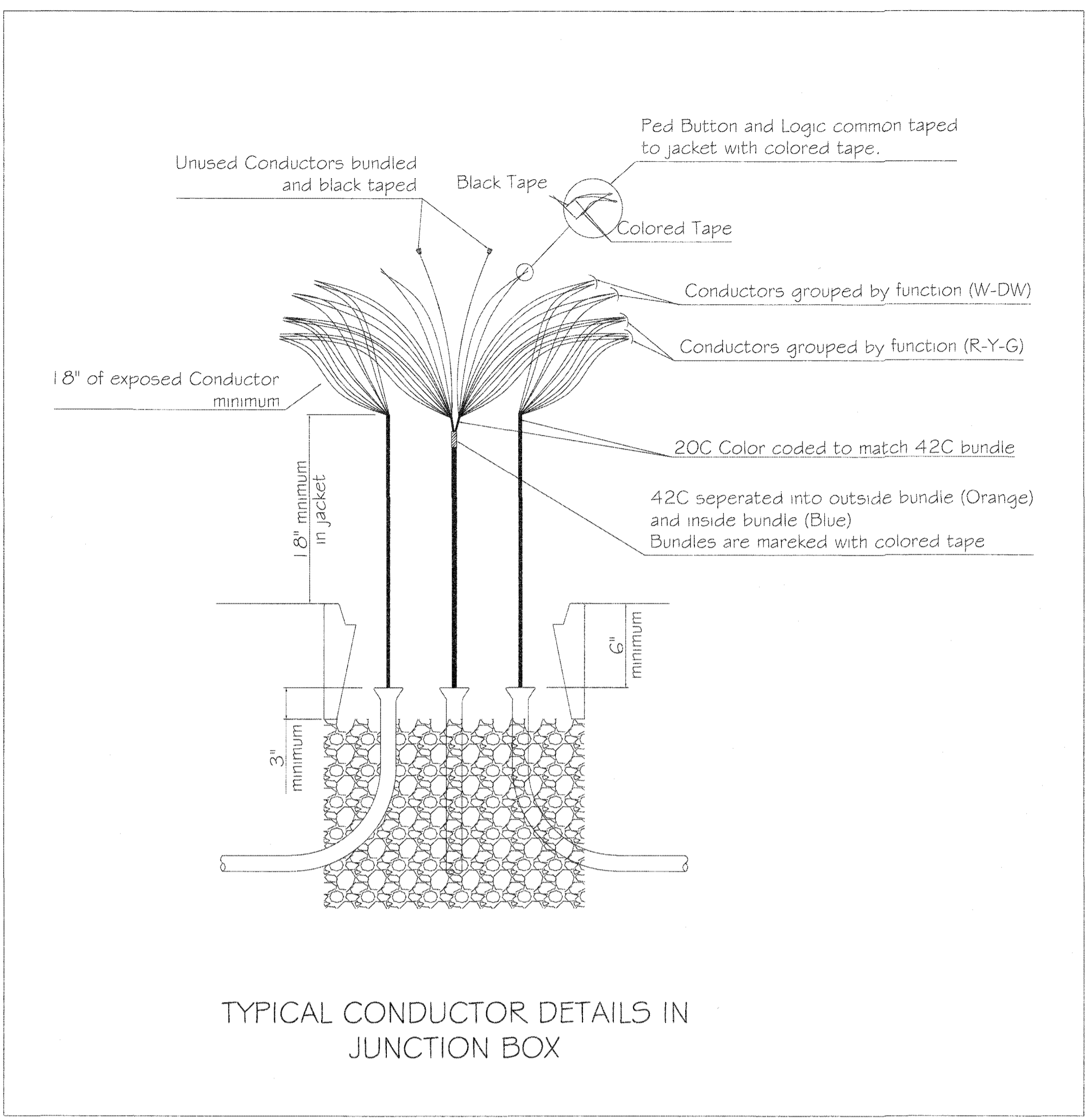
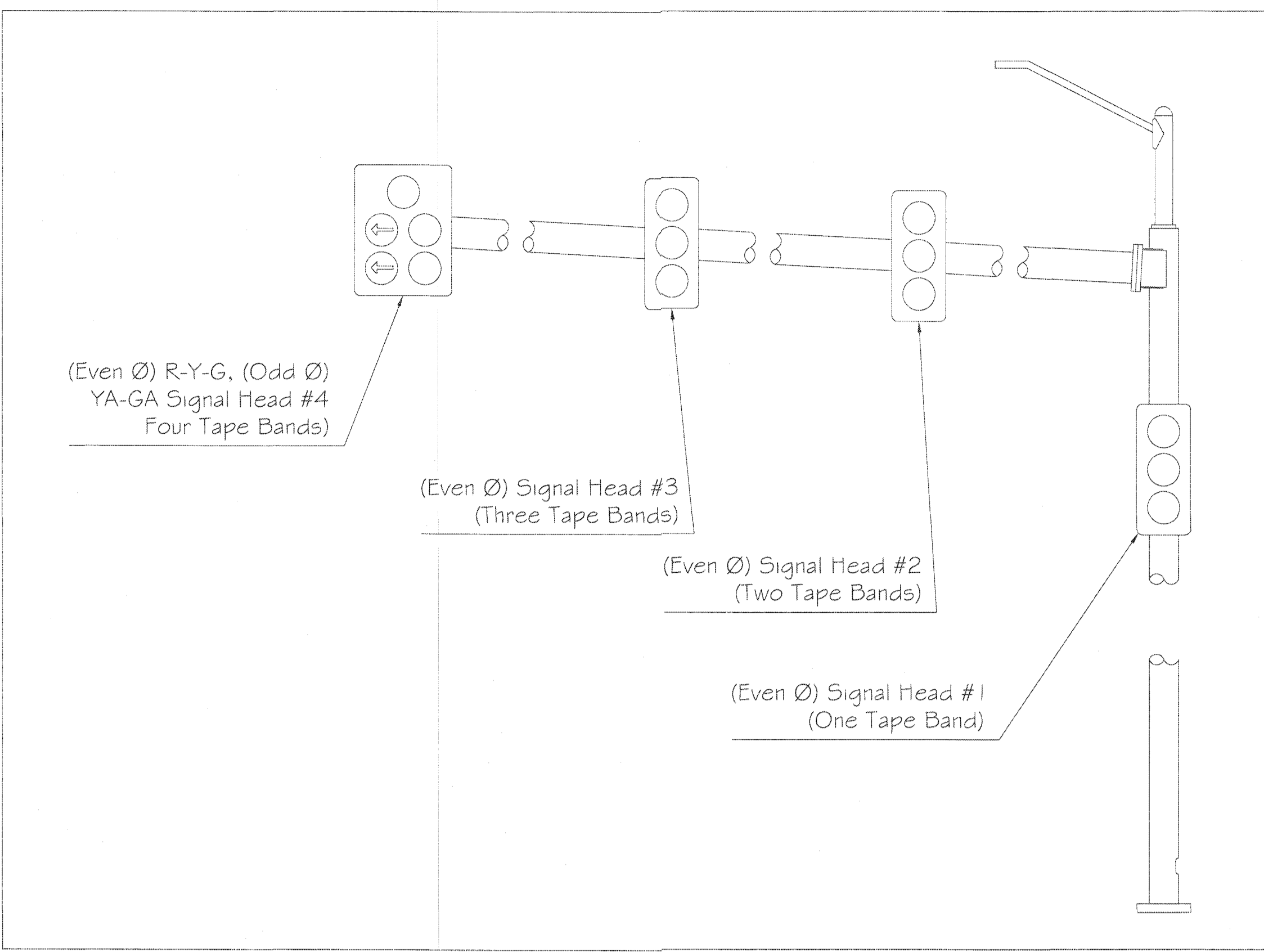

"PER CITY OF PHOENIX CITY CODE CHAPTER 2, SECTION 2-26, THESE PLANS ARE FOR OFFICIAL USE ONLY & MAY NOT BE SHARED WITH OTHERS EXCEPT AS REQUIRED TO FULFILL THE OBLIGATIONS OF YOUR CONTRACT WITH THE CITY OF PHOENIX."

CITY OF PHOENIX, ARIZONA
STREET TRANSPORTATION DEPARTMENT
TRAFFIC SIGNAL STANDARD DETAILS

TRAFFIC SIGNAL DETAILS
CITY OF PHOENIX, ARIZONA
STREET TRANSPORTATION DEPARTMENT

PULL BOX/POLE HAND HOLE WIRING

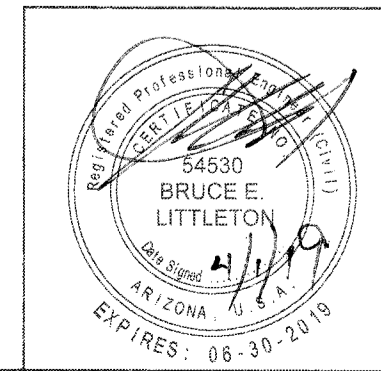

TPP File Number 10164
TS 4-2
DATE: 4-1-2019

PROJECT #:	DR:	DES:	CK:	SHEET NO:	TOTAL SHEETS:
	DATE:	DATE:	DATE:		
SCALE:	QS #:				

F.H.W.A. REGION	STATE	PROJ. NO.	NO.	TOTAL
9	ARIZ.			
DR:		DES:	CK:	DATE:

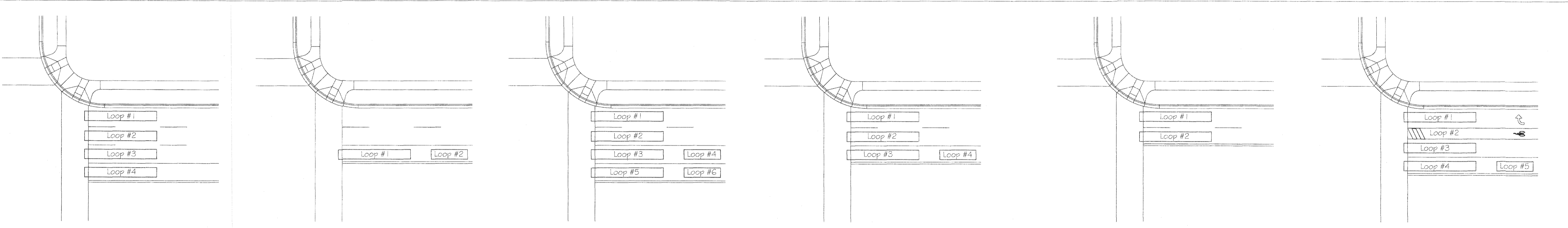
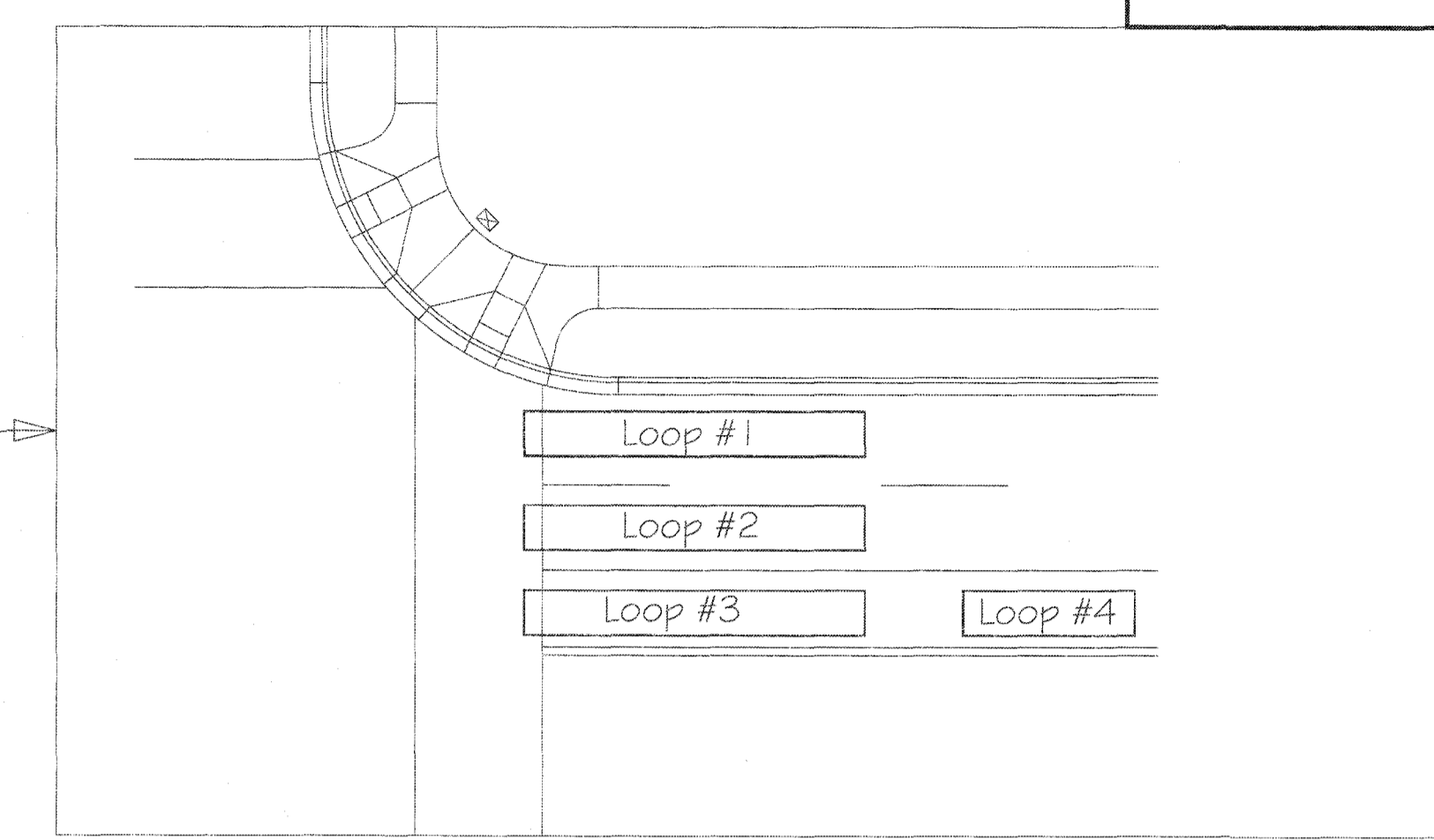
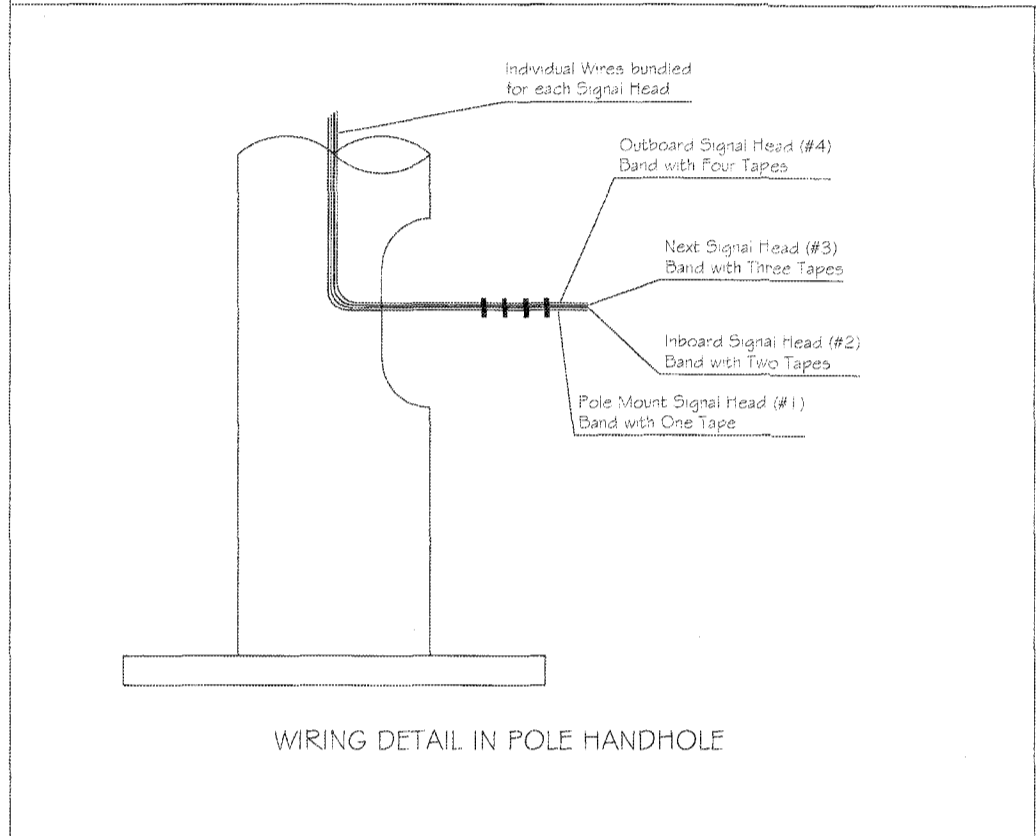
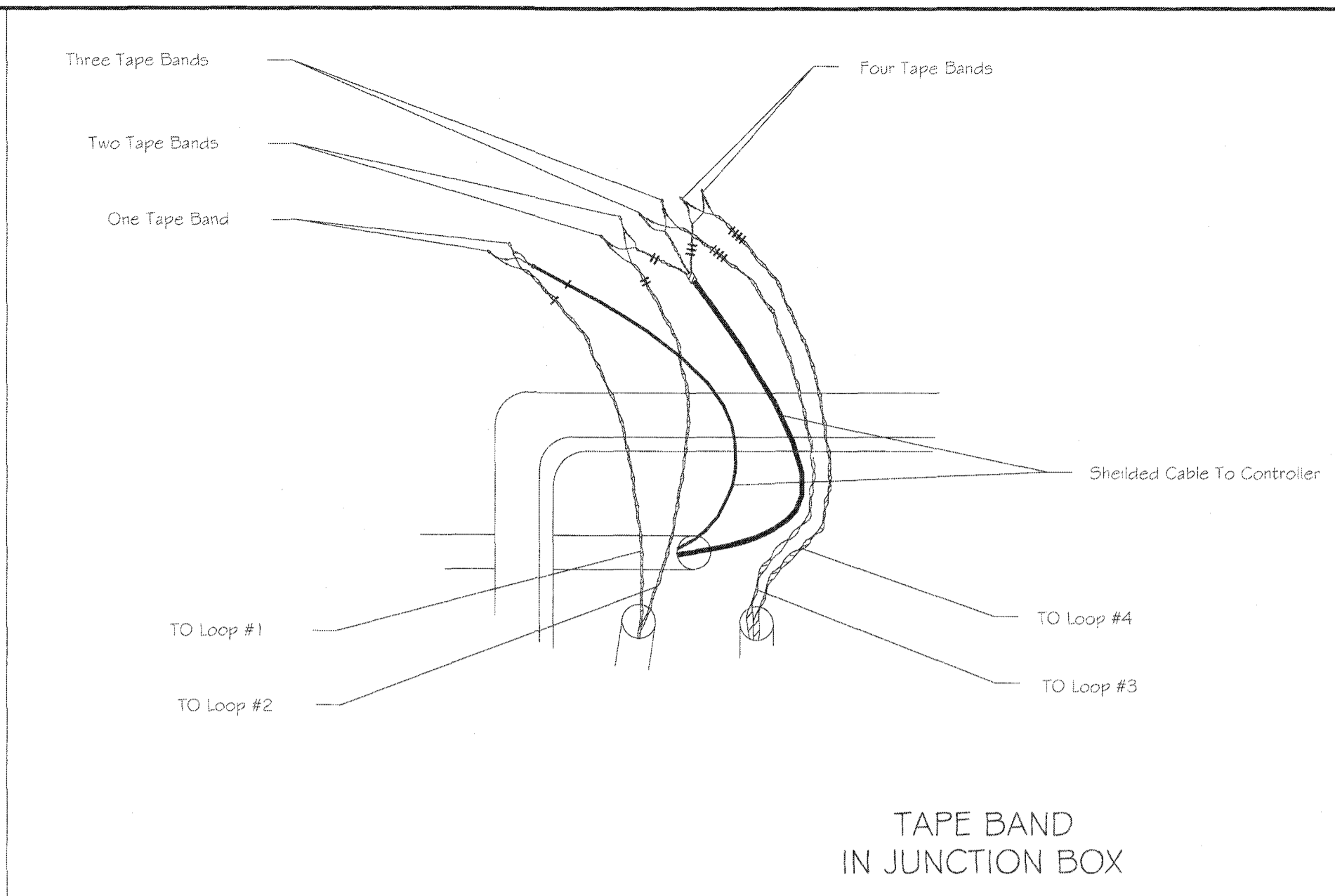
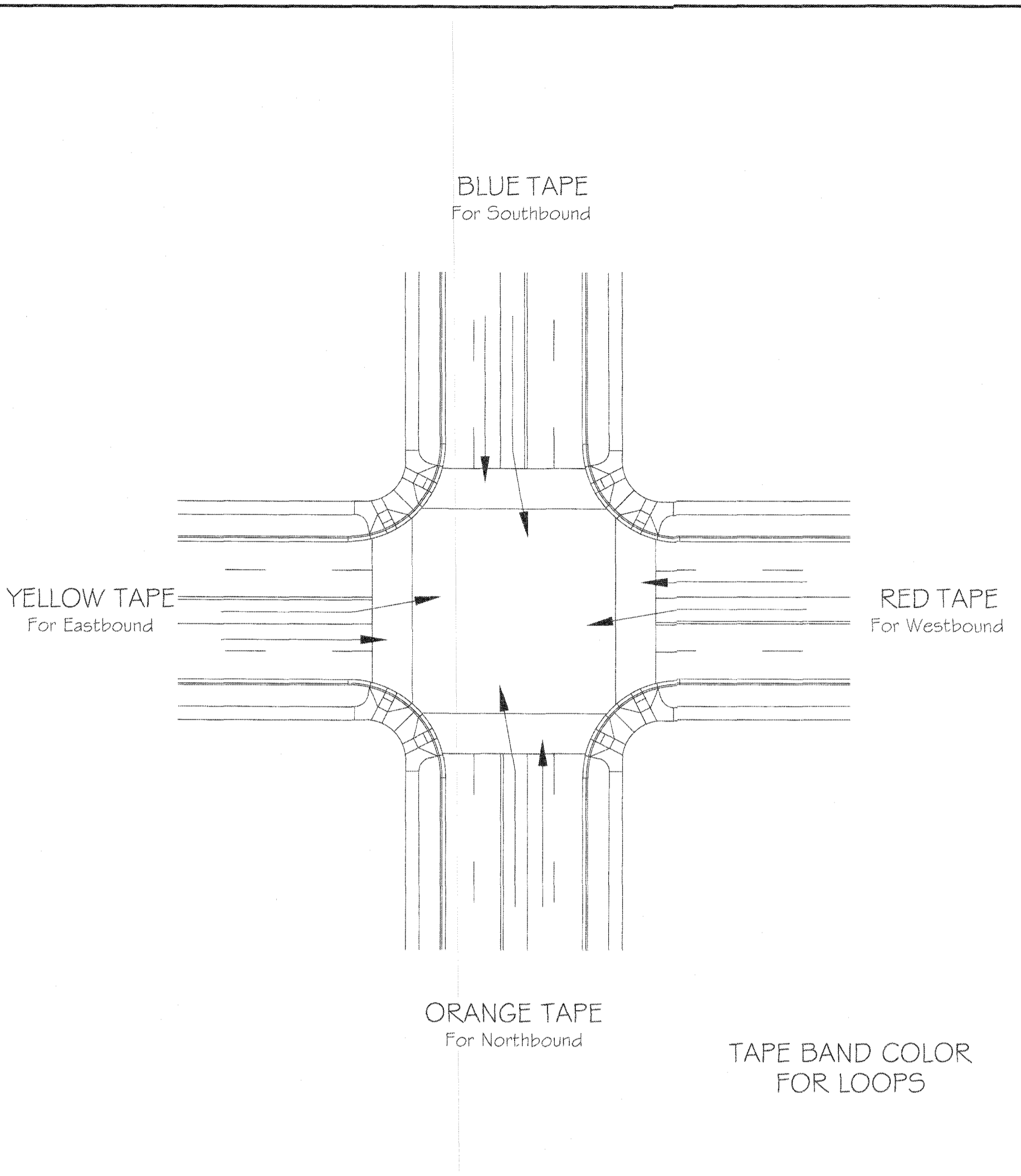

- 1 - Loop numbering begins with the right most internal loop numbered #1
- 2 - Loops are numbered sequentially in the lane, then to the adjacent lane
- 3 - Numbering starts over with each approach
- 4 - See approved plans for loop locations

PER CITY OF PHOENIX CITY CODE CHAPTER 2, SECTION 2-26, THESE PLANS ARE FOR OFFICIAL USE ONLY & MAY NOT BE SHARED WITH OTHERS EXCEPT AS REQUIRED TO FULFILL THE OBLIGATIONS OF YOUR CONTRACT WITH THE CITY OF PHOENIX.

CITY OF PHOENIX, ARIZONA
STREET TRANSPORTATION DEPARTMENT
TRAFFIC SIGNAL STANDARD DETAILS

TRAFFIC SIGNAL DETAILS
CITY OF PHOENIX, ARIZONA
STREET TRANSPORTATION DEPARTMENT

**COLOR CODING/BANDING SCHEME
LOOP NUMBERING**

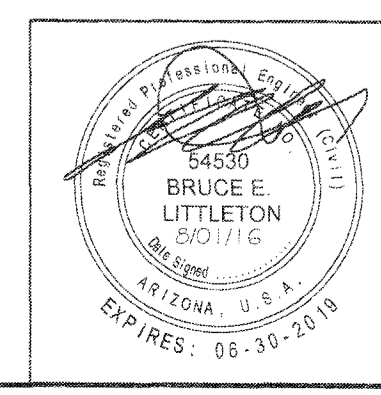

TPP File Number: 10164
TS 4-3
DATE: 8-1-2016
TRAFFIC SERVICES DEPUTY DIRECTOR

PROJECT #:	DR:	DES:	CK:	SHEET NO:	TOTAL SHEETS:
	DATE:	DATE:	DATE:		
SCALE:	Q5. #:				

F.H.W.A. REGION	STATE	PROJ. NO.	NO.	TOTAL
9	ARIZ.			
DR:	DES:	CK:	DATE:	

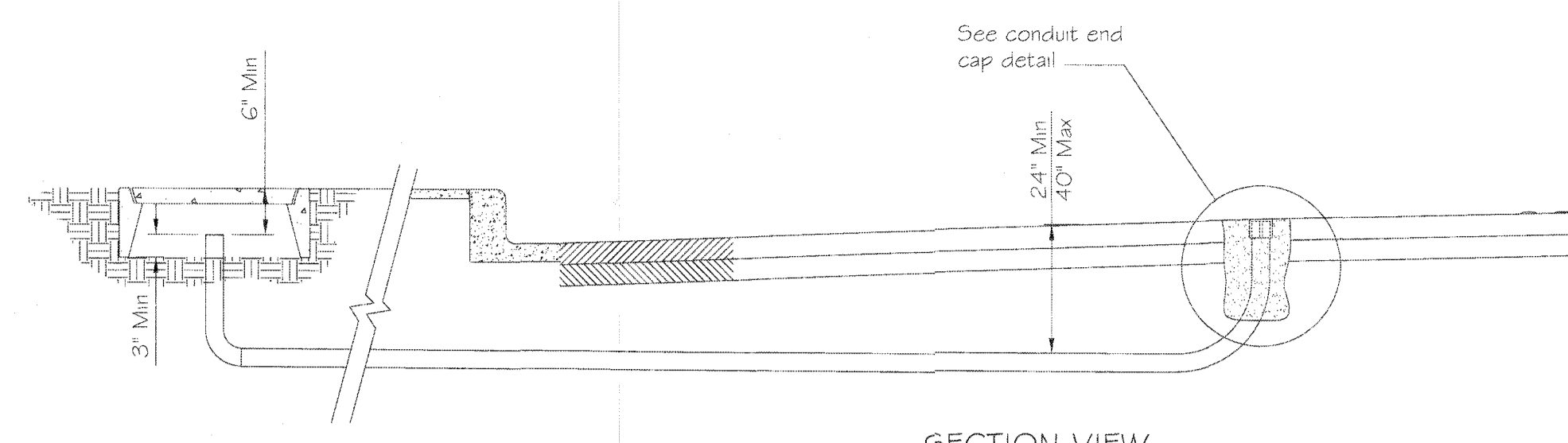

SECTION VIEW

LOOP TO JUNCTION BOX DETAIL

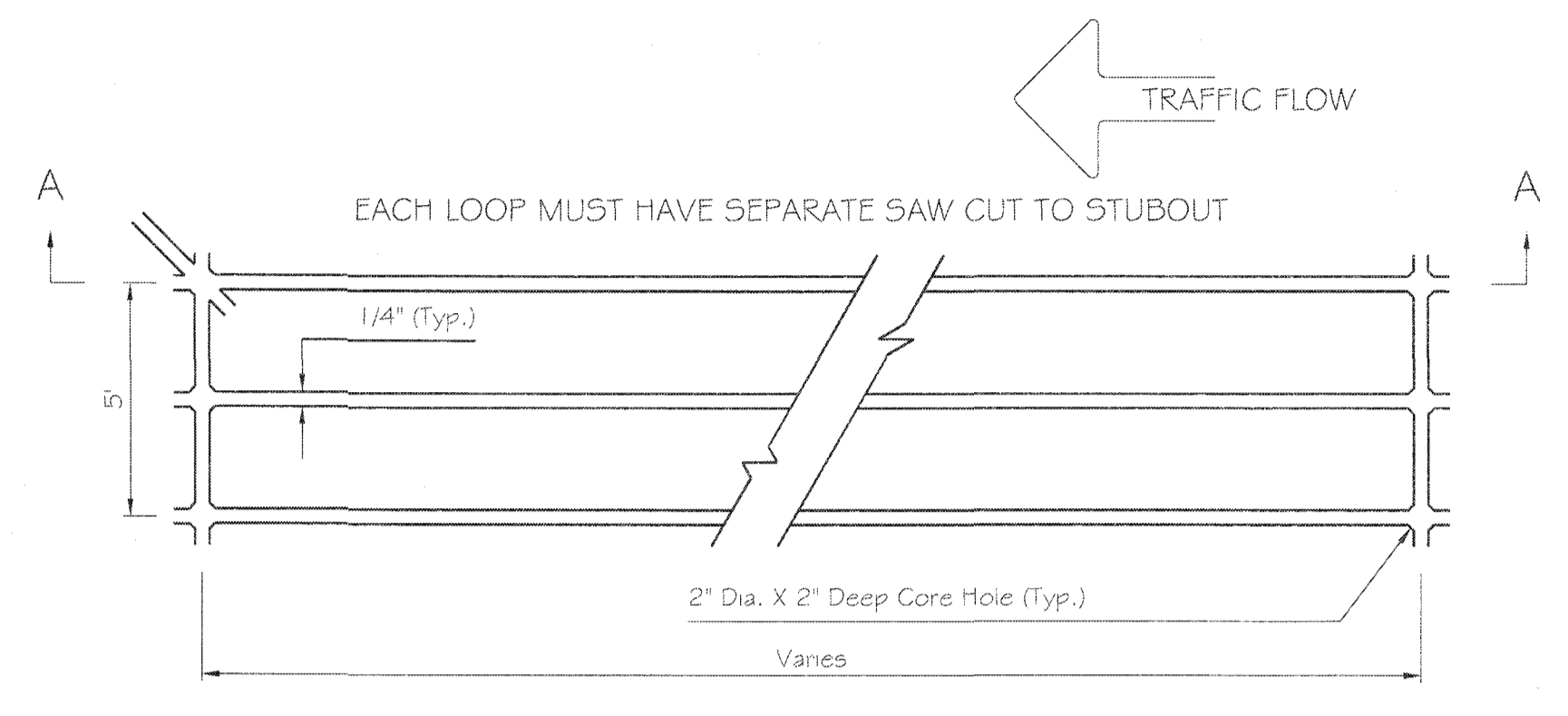
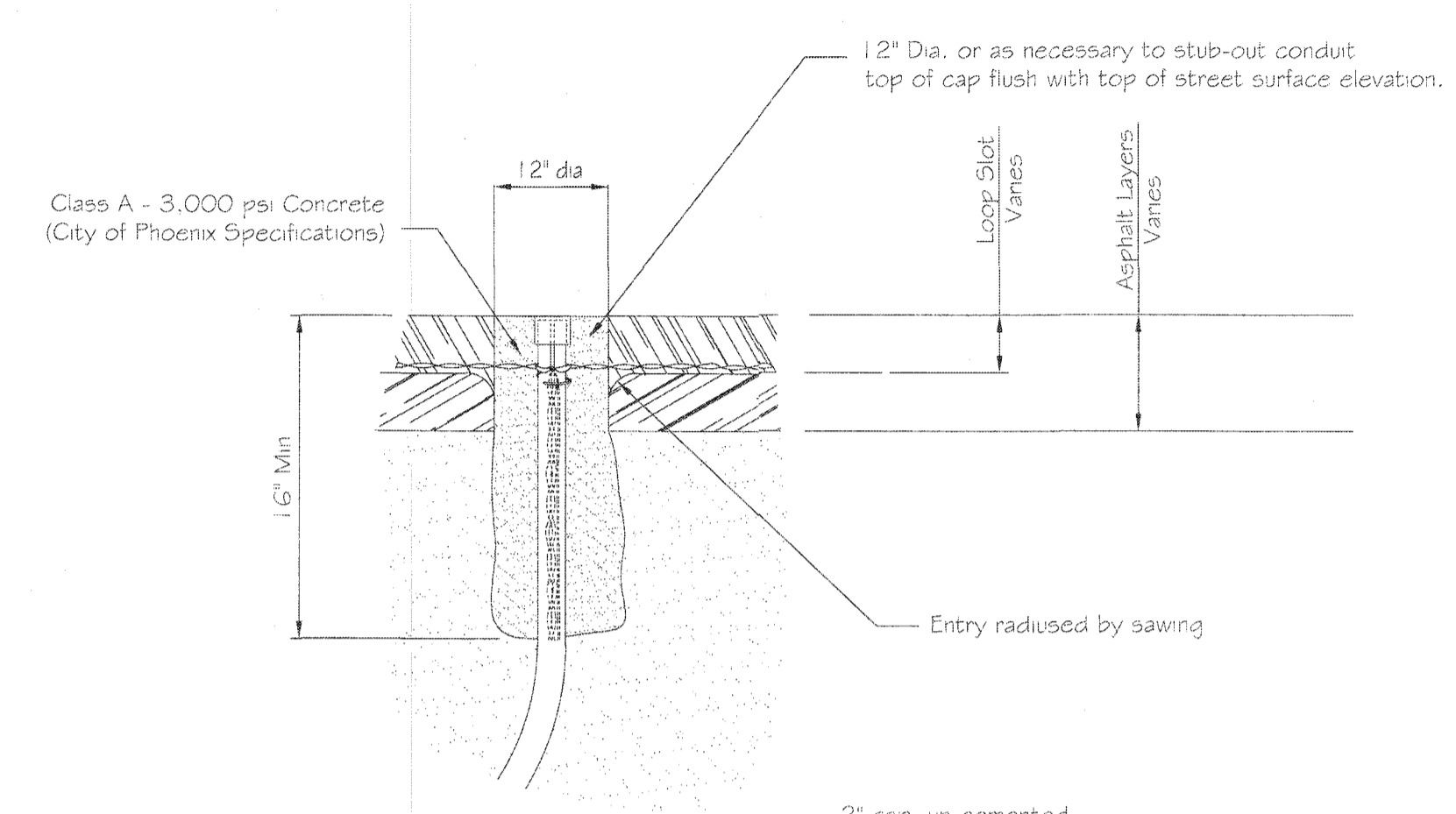

QUADRUPOLE DETECTOR LOOP SAW CUT DETAIL

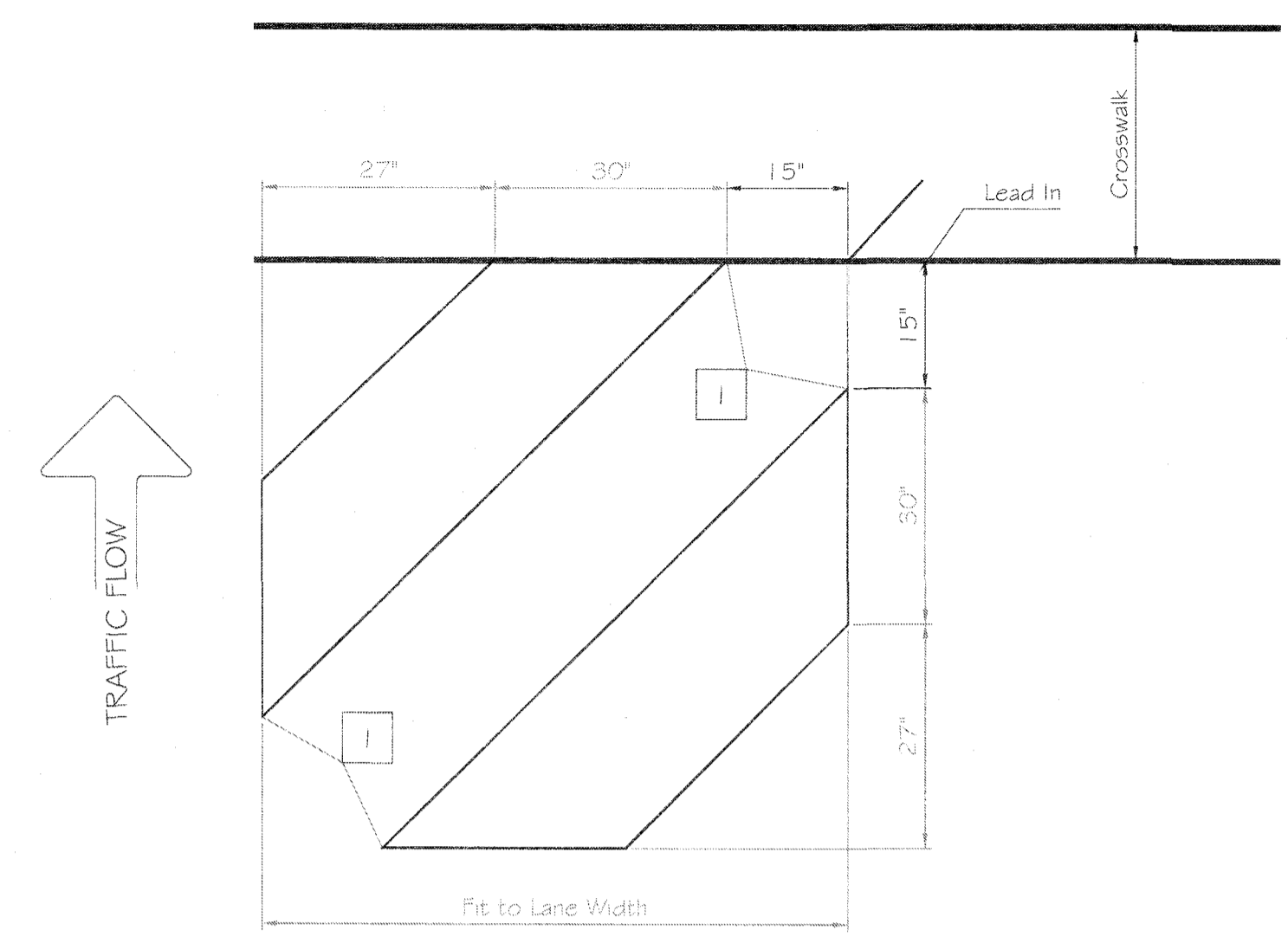

BICYCLE DETECTOR LOOP SAW CUT DETAIL

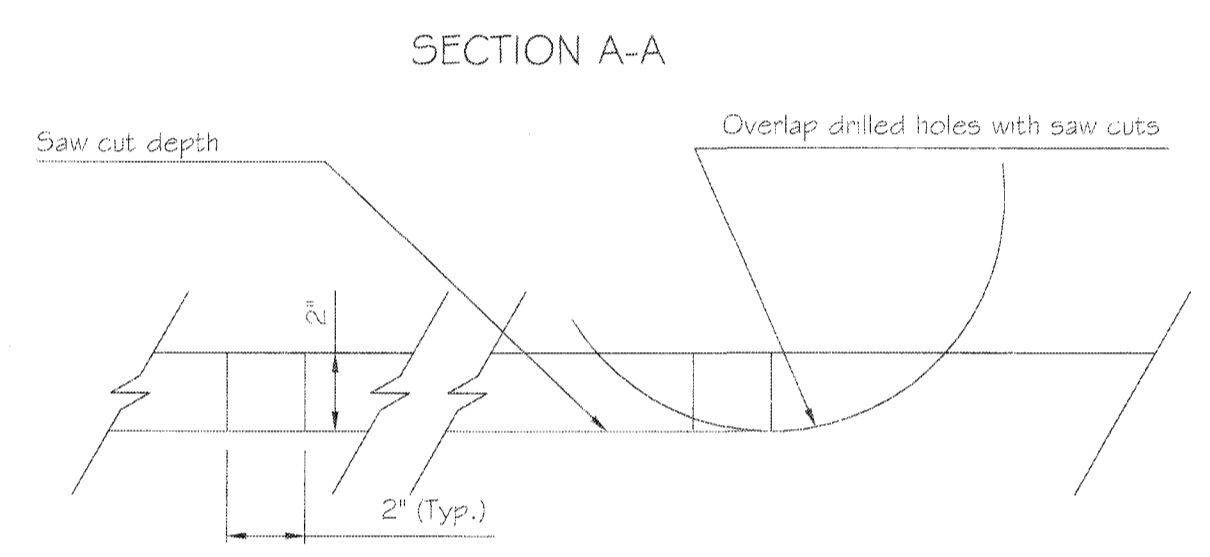

SECTION A-A

- 1 Round corners of acute angle sawcuts to prevent damage to conductors
- 2 5 Turns

CONDUIT END CAP DETAIL

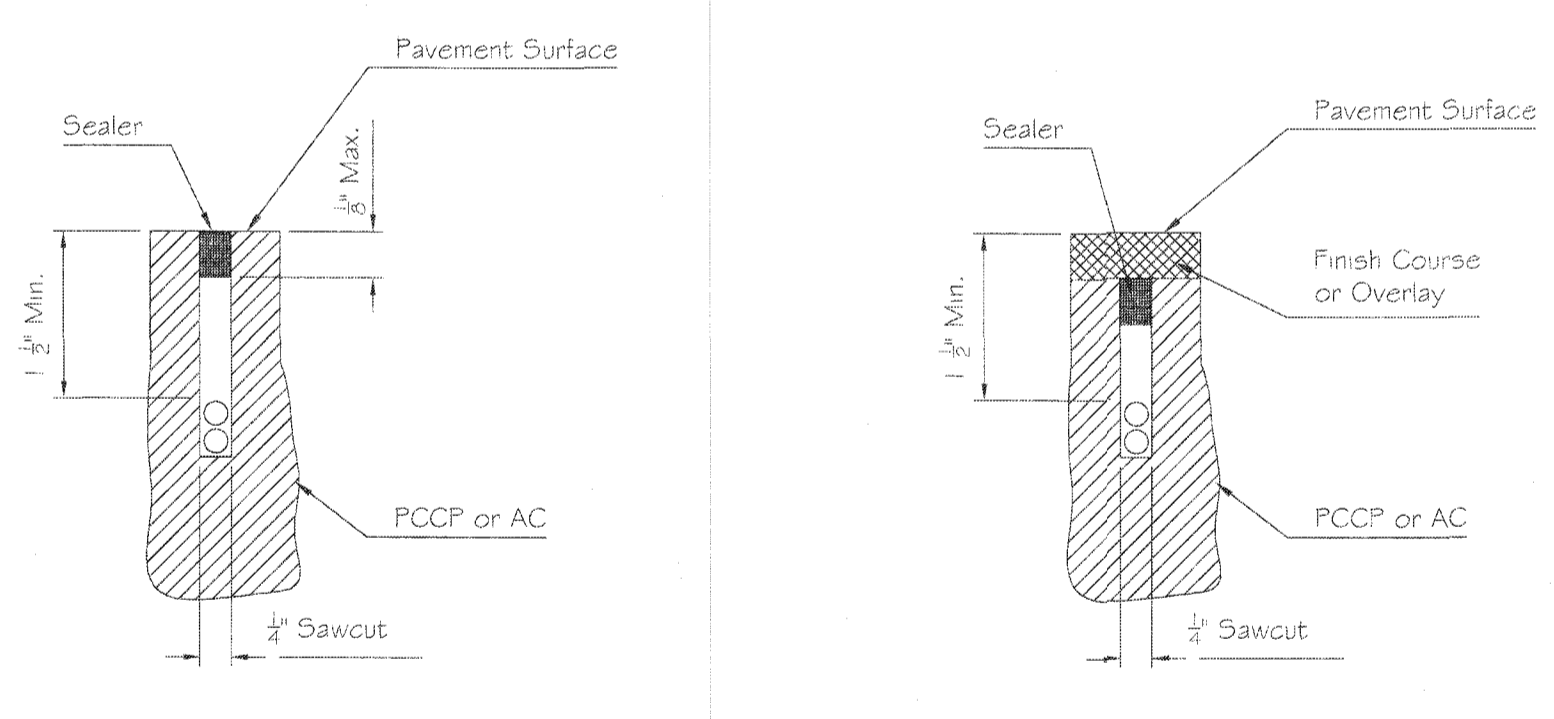

DETAIL 1

DETAIL 2

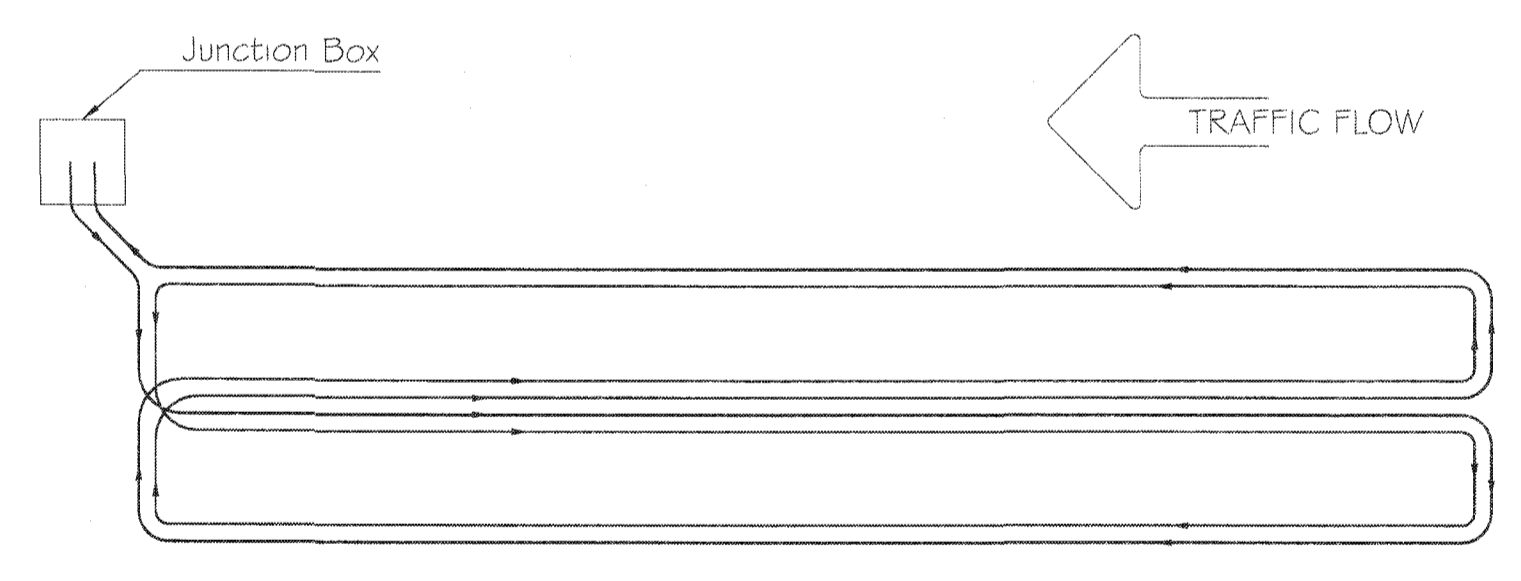

QUADRUPOLE DETECTOR LOOP CONDUCTOR PLACEMENT

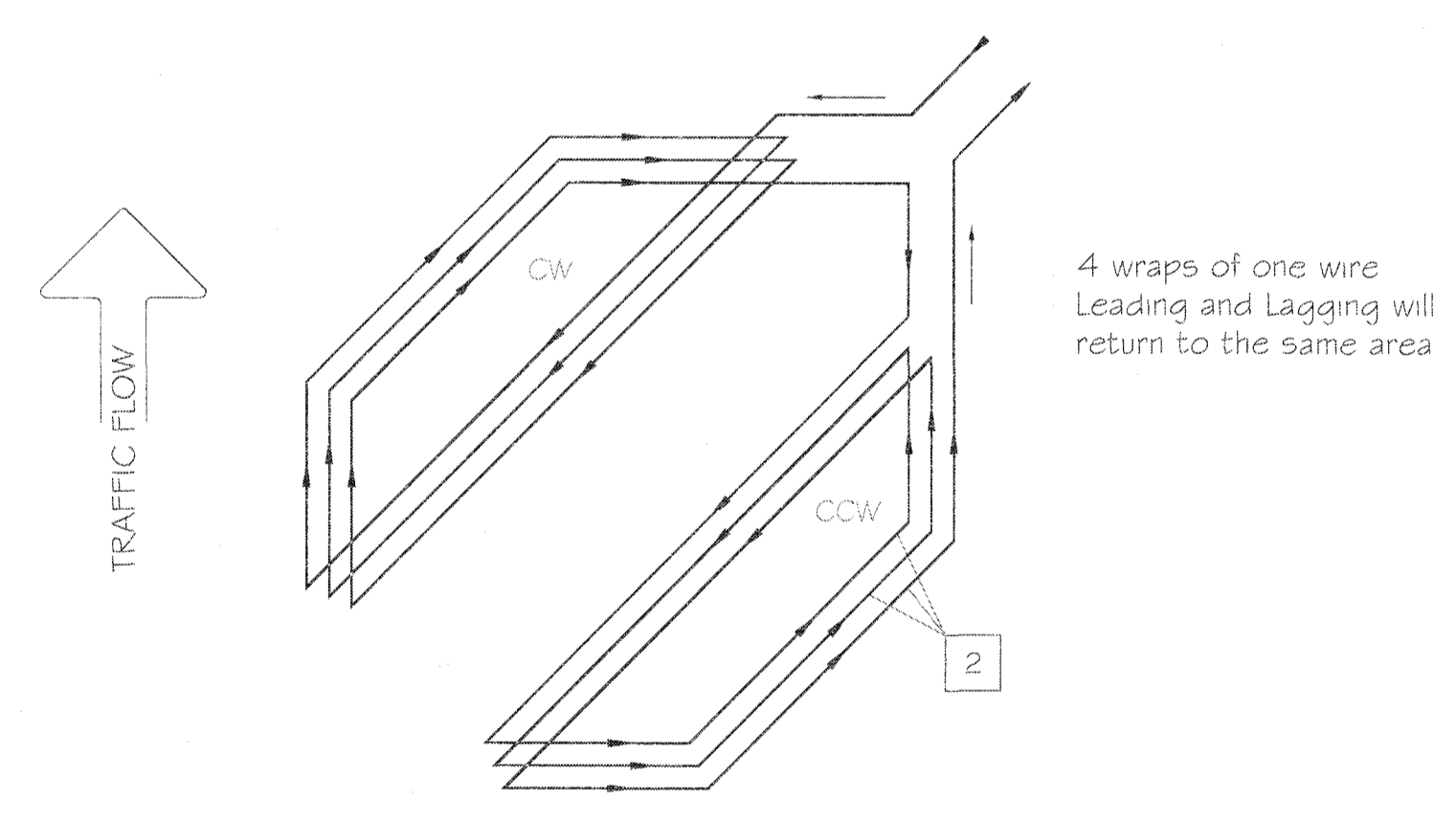

BICYCLE DETECTOR LOOP CONDUCTOR PLACEMENT

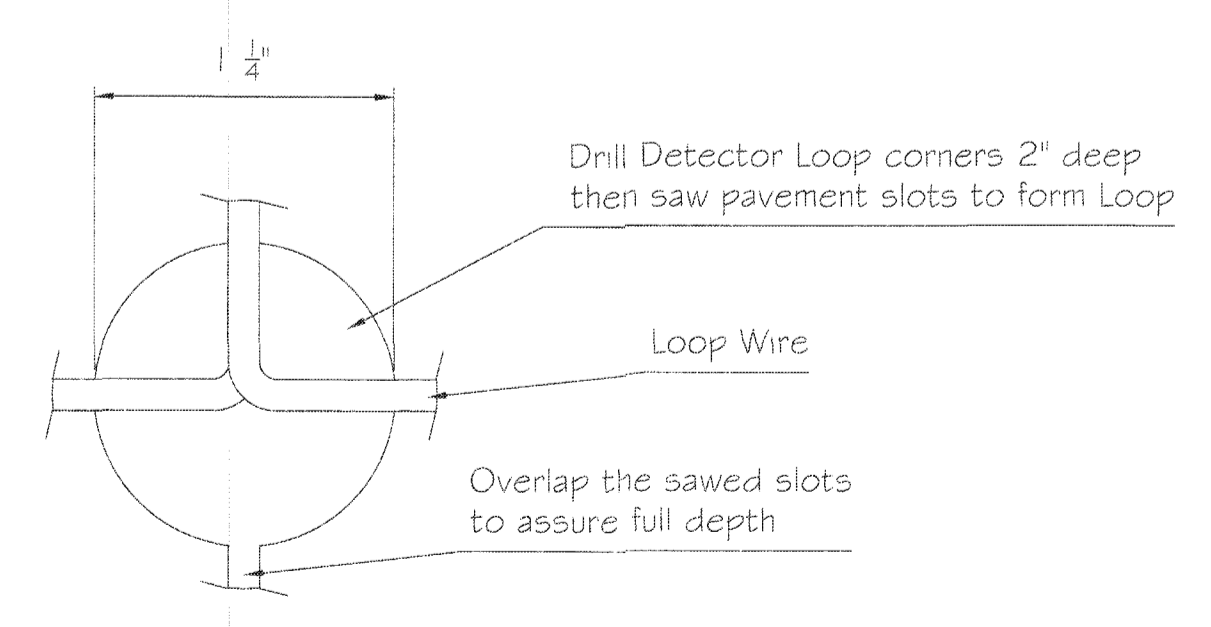

DRILLING DETAIL

"PER CITY OF PHOENIX CITY CODE CHAPTER 2, SECTION 2-26, THESE PLANS ARE FOR OFFICIAL USE ONLY & MAY NOT BE SHARED WITH OTHERS EXCEPT AS REQUIRED TO FULFILL THE OBLIGATIONS OF YOUR CONTRACT WITH THE CITY OF PHOENIX."

CITY OF PHOENIX, ARIZONA
STREET TRANSPORTATION DEPARTMENT
TRAFFIC SIGNAL STANDARD DETAILS

TRAFFIC SIGNAL DETAILS
CITY OF PHOENIX, ARIZONA
STREET TRANSPORTATION DEPARTMENT

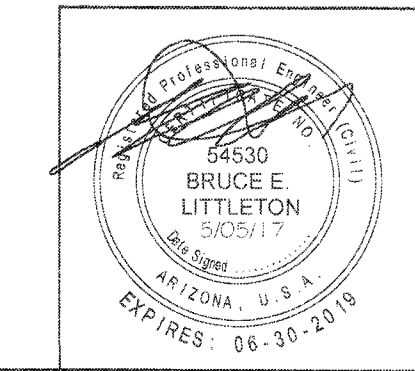

DETECTION LOOPS

TPP File Number: 00164
TS 5-1
DATE: 5-08-2017

PROJECT #:	DR:	DES:	CK:	SHEET NO:	TOTAL SHEETS:
	DATE:	DATE:	DATE:		
	SCALE:	QS #:			

F.H.W.A. REGION	STATE	PROJ. NO.	NO.	TOTAL
9	ARIZ.			

DR:	DES:	CK:	DATE:
-----	------	-----	-------

CLEAR SPACE NOTES:

1. PUSH BUTTON SHALL HAVE A 2.5 FT MIN (4 FT PREFERRED) X 4 FT CLEAR SPACE CENTERED AT PUSH BUTTON.
2. CONCRETE CURB AND GUTTER AT CURB RETURNS WITH CURB RAMP'S SHALL BE M.A.G. CLASS A. CONCRETE SIDEWALKS AND CURB RAMP'S AT CURB RETURNS SHALL BE M.A.G. CLASS A.
3. PUSH BUTTON FACE SHALL BE ALIGNED WITH PEDESTRIAN DIRECTION OF TRAVEL.
4. MAINTAIN THE PLANE OF THE LANDING ONE FOOT (FT.) BEYOND THE TOP OF LANDING.
5. ADDITIONAL SIDEWALK PER NOTES 2 & 5 WHEN SIGNAL POLES WITH PUSH BUTTONS ARE LOCATED IN THESE MINIMUM 1.5 FT OF SIDEWALK MUST BE PROVIDED BETWEEN FACE OF CURB AND EDGE OF PUSH BUTTON POLE (2 FT PREFERRED).
6. PUSH BUTTON SHOULD BE 1.5 FT TO 6 FT FROM EDGE OF CURB. IF PUSH BUTTON CANNOT BE LOCATED WITHIN 6 FT FROM EDGE OF CURB, IT SHOULD NOT BE FURTHER THAN 10 FT FROM EDGE OF CURB.
7. PUSH BUTTON CLEAR SPACE AREA TO BE CONCRETE SIDEWALK.
8. BEYOND THE BOTTOM GRADE BREAK, A CLEAR SPACE OF 4 FT MINIMUM BY 4 FT MINIMUM SHALL BE PROVIDED WITH THE WIDTH OF THE PEDESTRIAN STREET CROSSING AND WHOLLY OUTSIDE THE PARALLEL VEHICLE TRAVEL LANE.
9. A 4 FT PEDESTRIAN ACCESS ROUTE IS REQUIRED FROM THE ACCEPTABLE AREA FOR PUSH BUTTON LOCATION TO THE EDGE OF CURB RAMP.

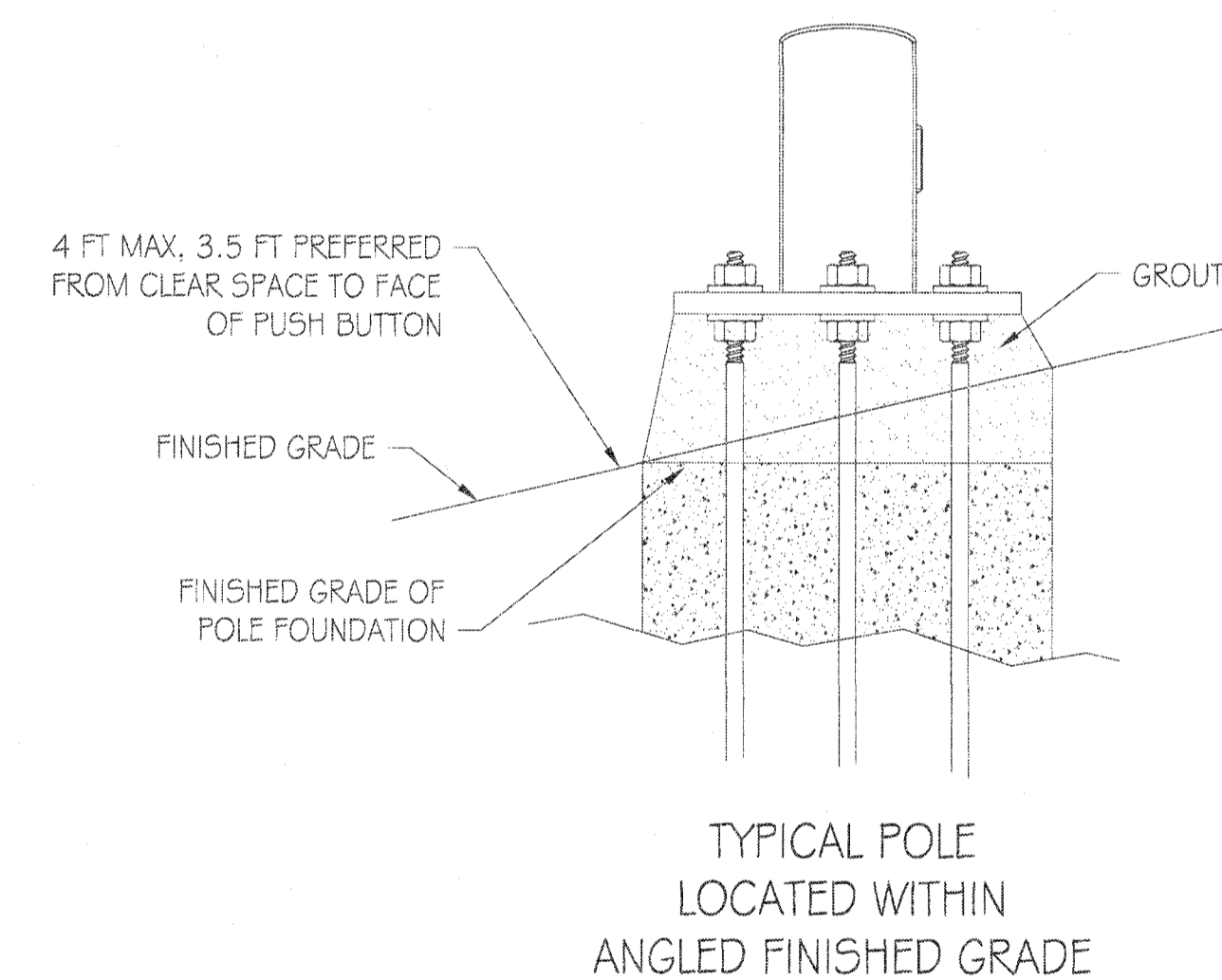
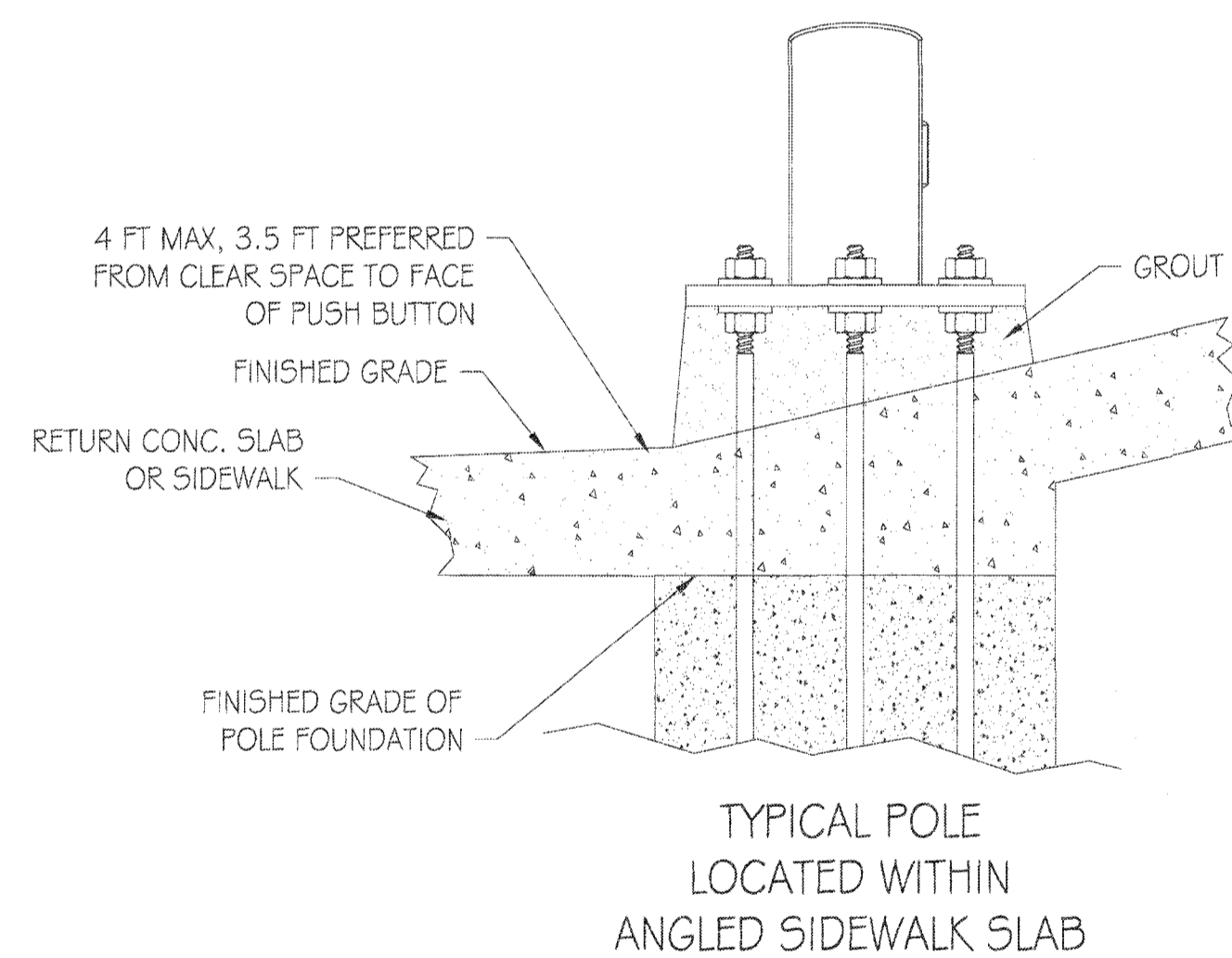
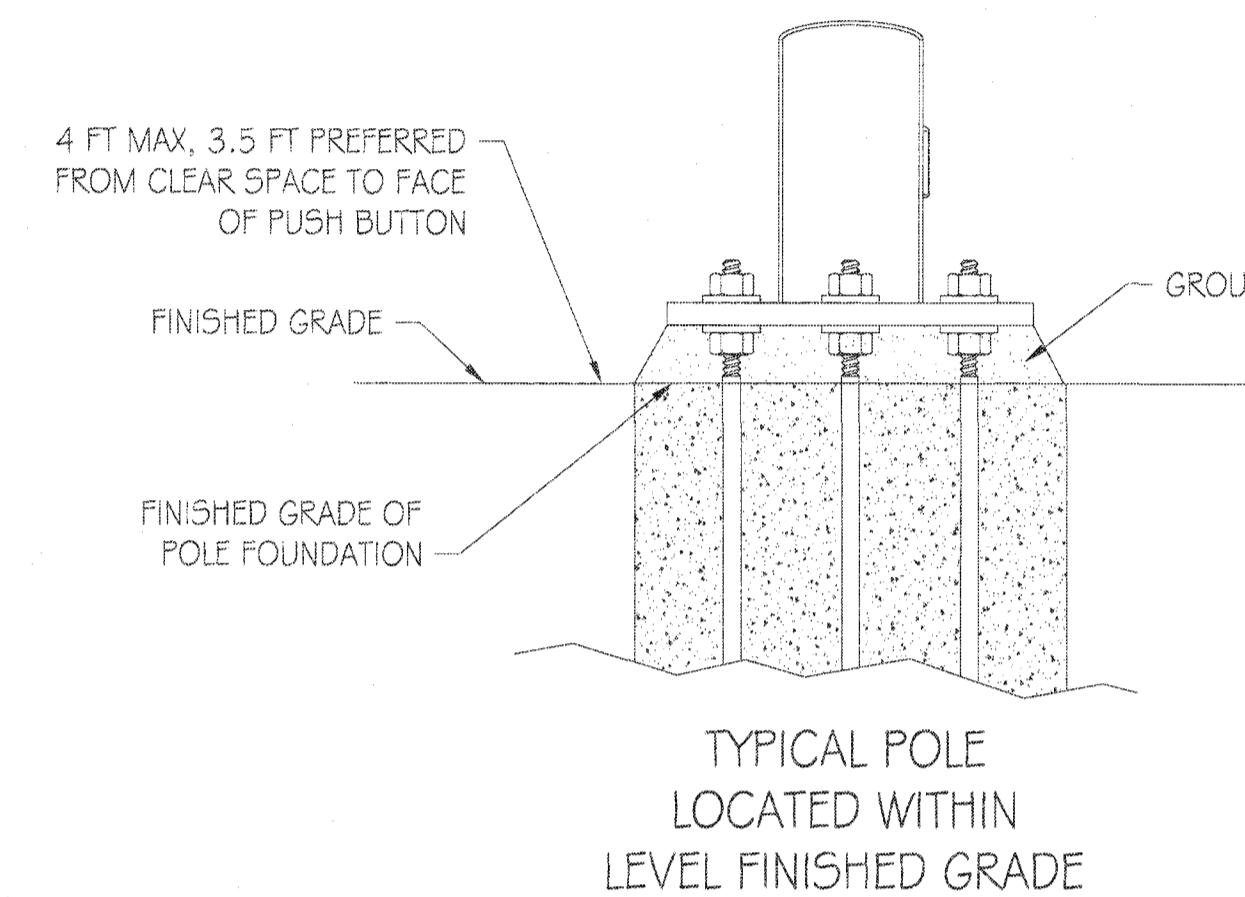
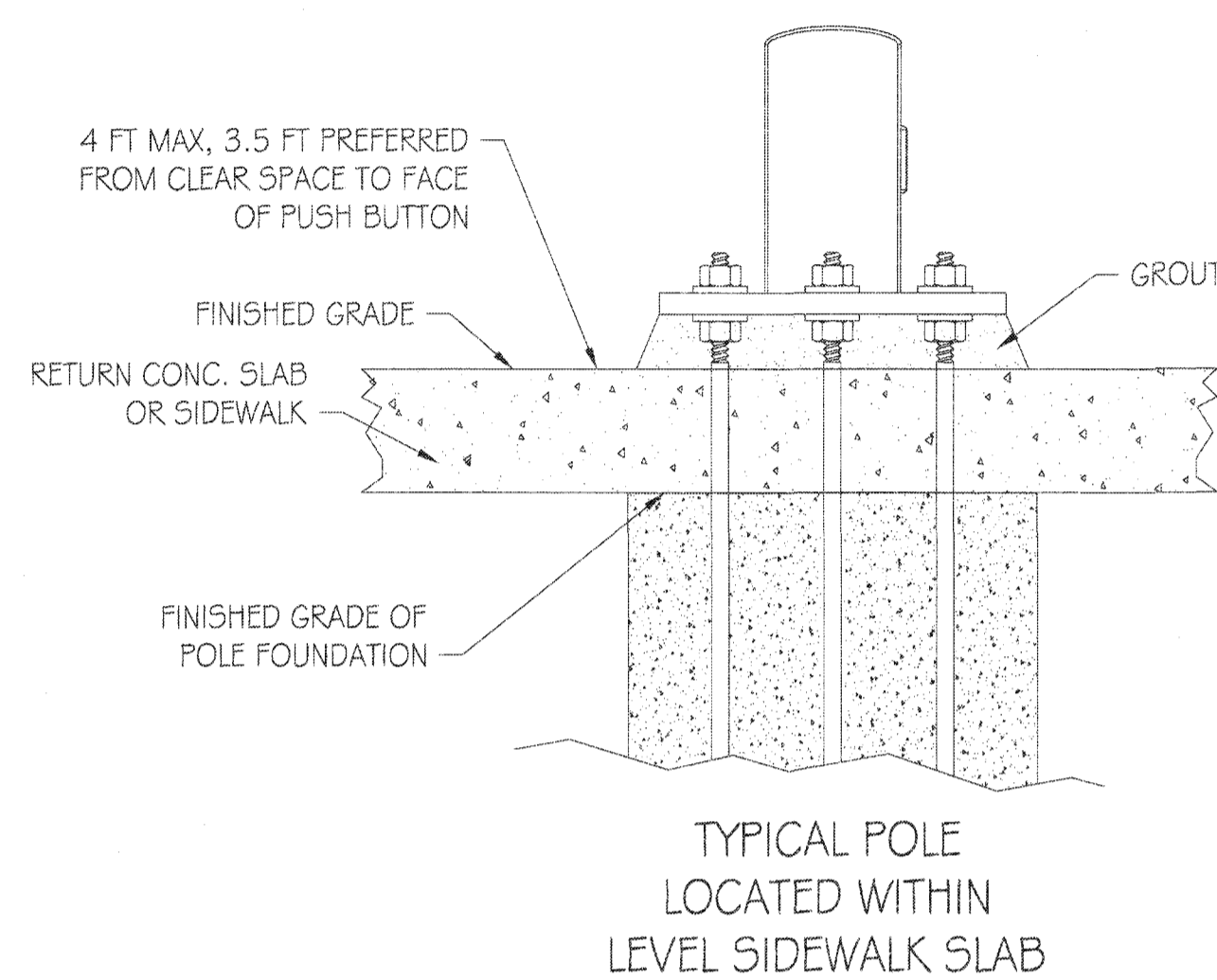
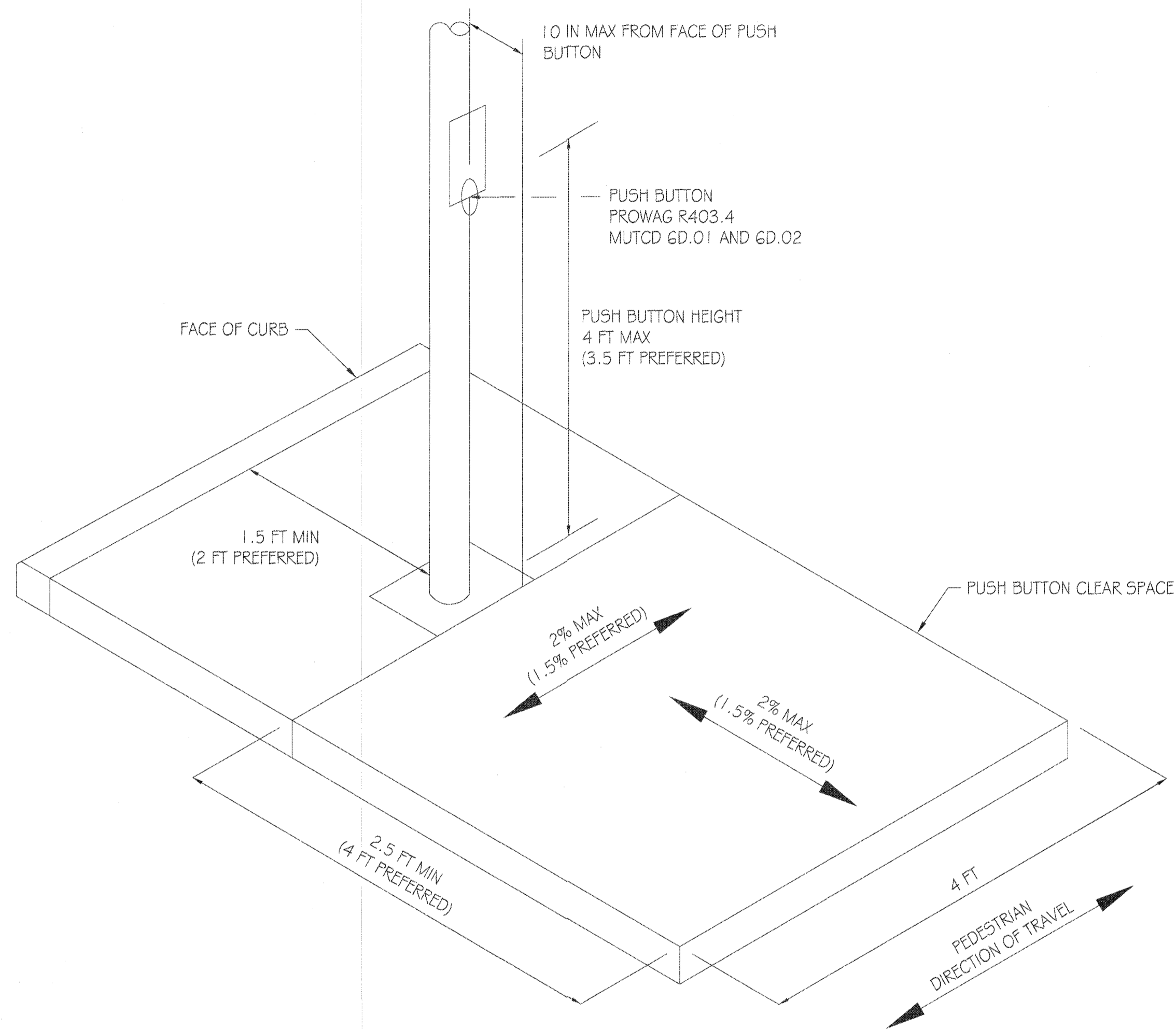

"PER CITY OF PHOENIX CITY CODE CHAPTER 2, SECTION 2-26, THESE PLANS ARE FOR OFFICIAL USE ONLY & MAY NOT BE SHARED WITH OTHERS EXCEPT AS REQUIRED TO FULFILL THE OBLIGATIONS OF YOUR CONTRACT WITH THE CITY OF PHOENIX."

CITY OF PHOENIX, ARIZONA
STREET TRANSPORTATION DEPARTMENT
TRAFFIC SIGNAL STANDARD DETAILS

TRAFFIC SIGNAL DETAILS
CITY OF PHOENIX, ARIZONA
STREET TRANSPORTATION DEPARTMENT

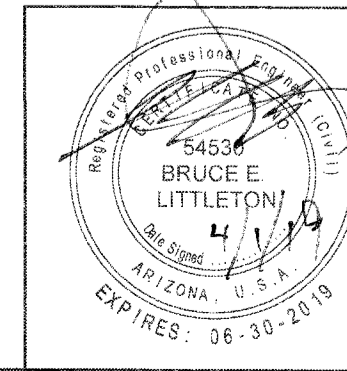

CLEAR SPACE DETAIL

TPP File Number: 00164 TS 6-1

DATE: 4-1-2019

PROJECT #:	DR:	DES:	CK:	SHEET NO.:	TOTAL SHEETS:
	DATE:	DATE:	DATE:		
	SCALE:	Q.S. #:			

F.H.W.A. REGION	STATE	PROJ. NO.	NO.	TOTAL
9	ARIZ.			

DR:	DES:	CK:	DATE:

NOTES:

- SEE DETAIL T5 G-1 FOR ALL NOTES.
- DRAWINGS NOT TO SCALE.

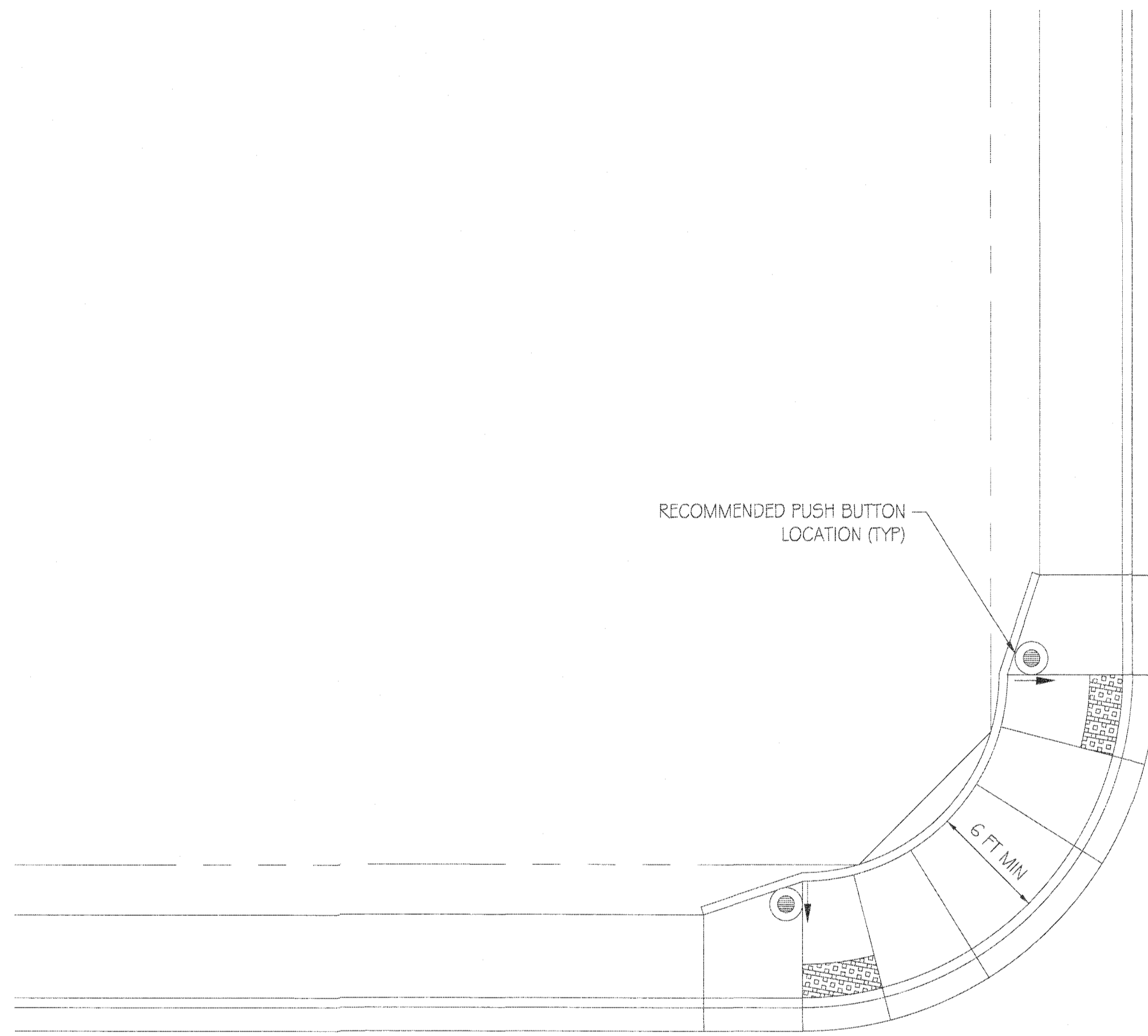
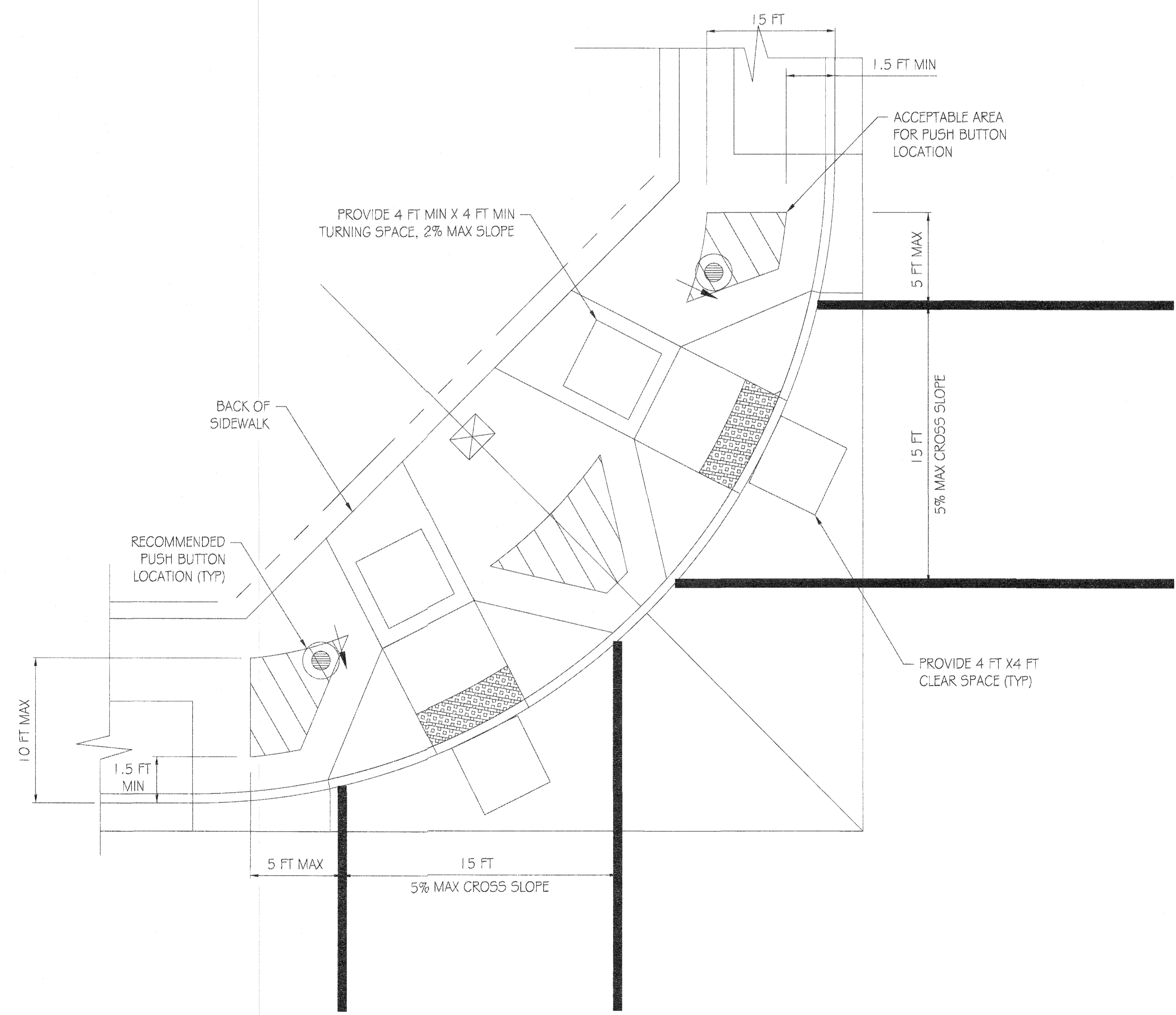
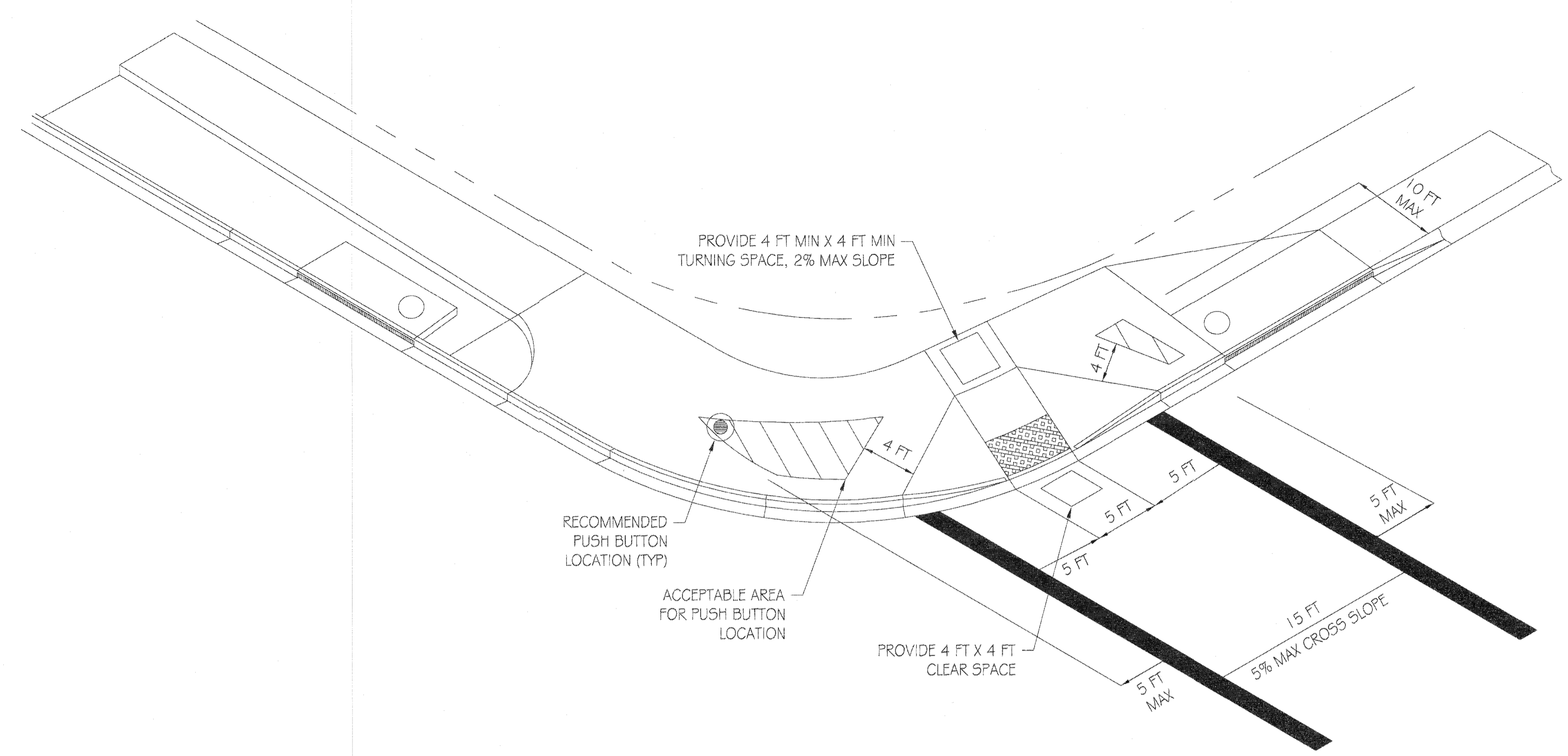

PER CITY OF PHOENIX CITY CODE CHAPTER 2, SECTION 2-26, THESE PLANS ARE FOR OFFICIAL USE ONLY & MAY NOT BE SHARED WITH OTHERS EXCEPT AS REQUIRED TO FULFILL THE OBLIGATIONS OF YOUR CONTRACT WITH THE CITY OF PHOENIX.

CITY OF PHOENIX, ARIZONA
STREET TRANSPORTATION DEPARTMENT
TRAFFIC SIGNAL STANDARD DETAILS

TRAFFIC SIGNAL DETAILS
CITY OF PHOENIX, ARIZONA
STREET TRANSPORTATION DEPARTMENT

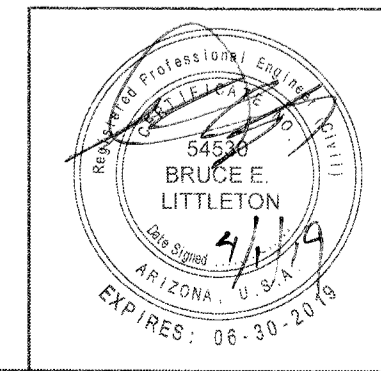

APRON JOINT, SINGLE CURB RAMP,
AND LIMITED RIGHT-OF-WAY

TPP File Number 10164 TS G-2
DATE: 4-1-2019
TRAFFIC SERVICES DEPUTY DIRECTOR

PROJECT #:	DR:	DES:	CK:	SHEET NO:	TOTAL SHEETS

F.H.W.A. REGION	STATE	PROJ. NO.	NO.	TOTAL
9	ARIZ.			

DR: _____ DES: _____ CK: _____ DATE: _____

NOTES:

1. SEE DETAIL TS 6-1 FOR ALL NOTES.
2. DRAWINGS NOT TO SCALE.

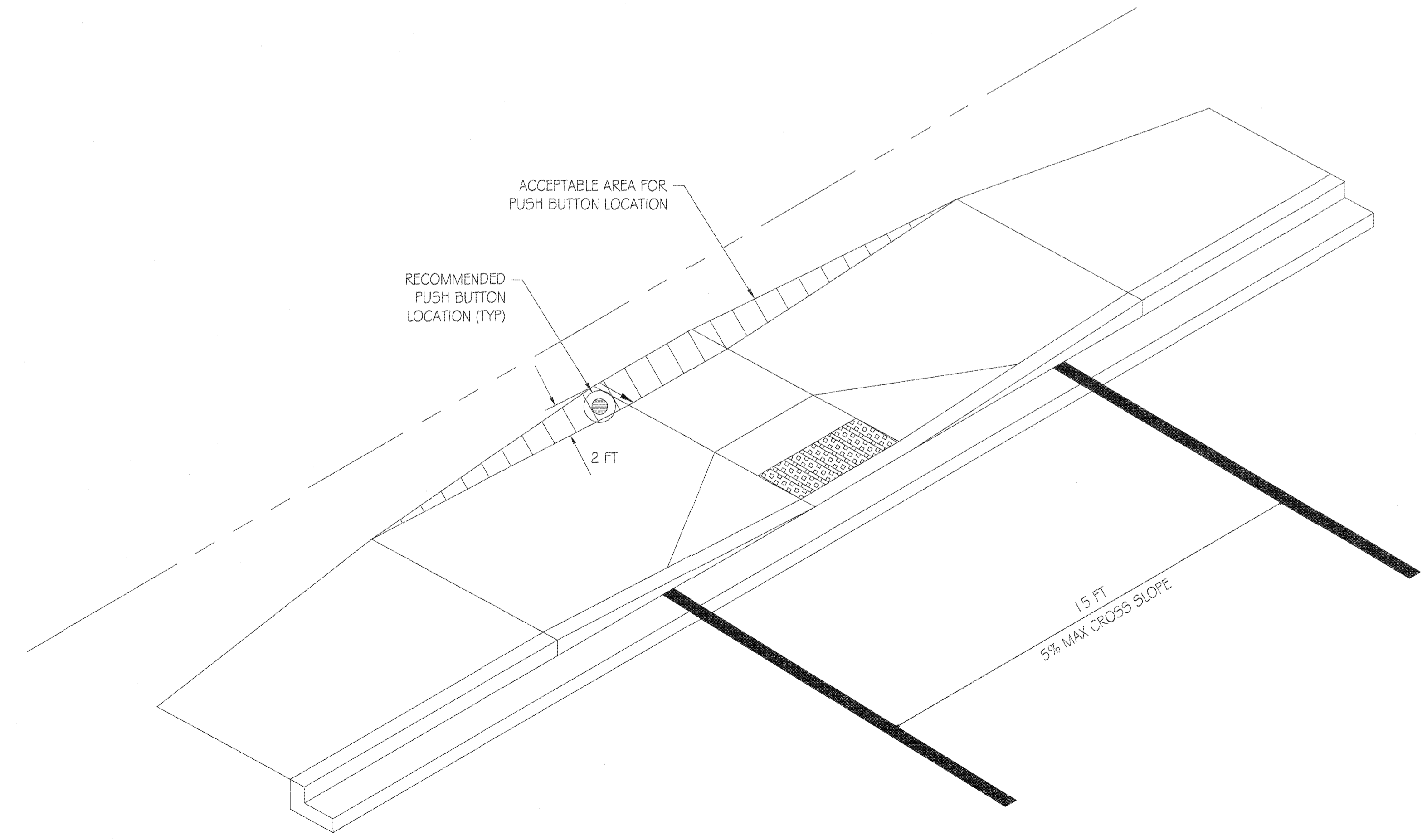
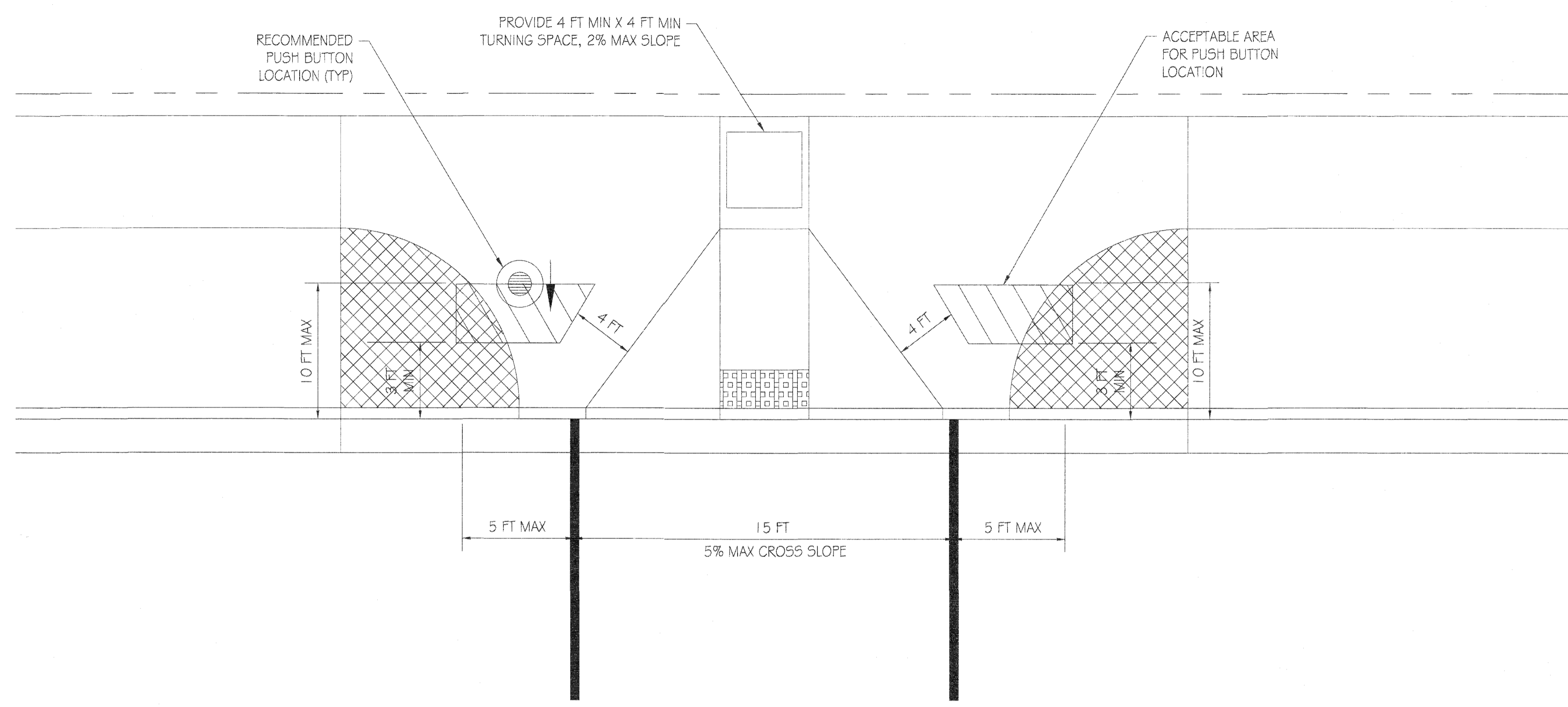

PER CITY OF PHOENIX CITY CODE CHAPTER 2, SECTION 2-26, THESE PLANS ARE FOR OFFICIAL USE ONLY & MAY NOT BE SHARED WITH OTHERS EXCEPT AS REQUIRED TO FULFILL THE OBLIGATIONS OF YOUR CONTRACT WITH THE CITY OF PHOENIX.

CITY OF PHOENIX, ARIZONA
STREET TRANSPORTATION DEPARTMENT
TRAFFIC SIGNAL STANDARD DETAILS

TRAFFIC SIGNAL DETAILS
CITY OF PHOENIX, ARIZONA
STREET TRANSPORTATION DEPARTMENT

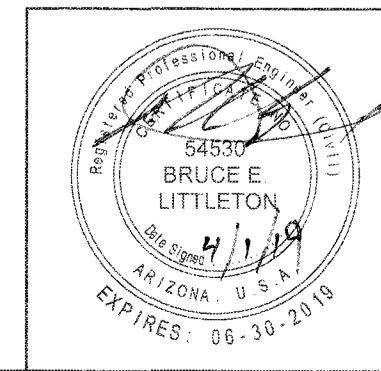

MID-BLOCK

TPP File Number 10164 TS 6-3

DATE: 4-1-2019

TRAFFIC SERVICES DEPUTY DIRECTOR

PROJECT #:	DR:	DES:	CK:	SHEET NO:	TOTAL SHEETS:
SCALE:	DATE:			QS #:	

CITY OF PHOENIX
 'SR' COMM SIGNAL POLE
 FOUNDATION DETAILS

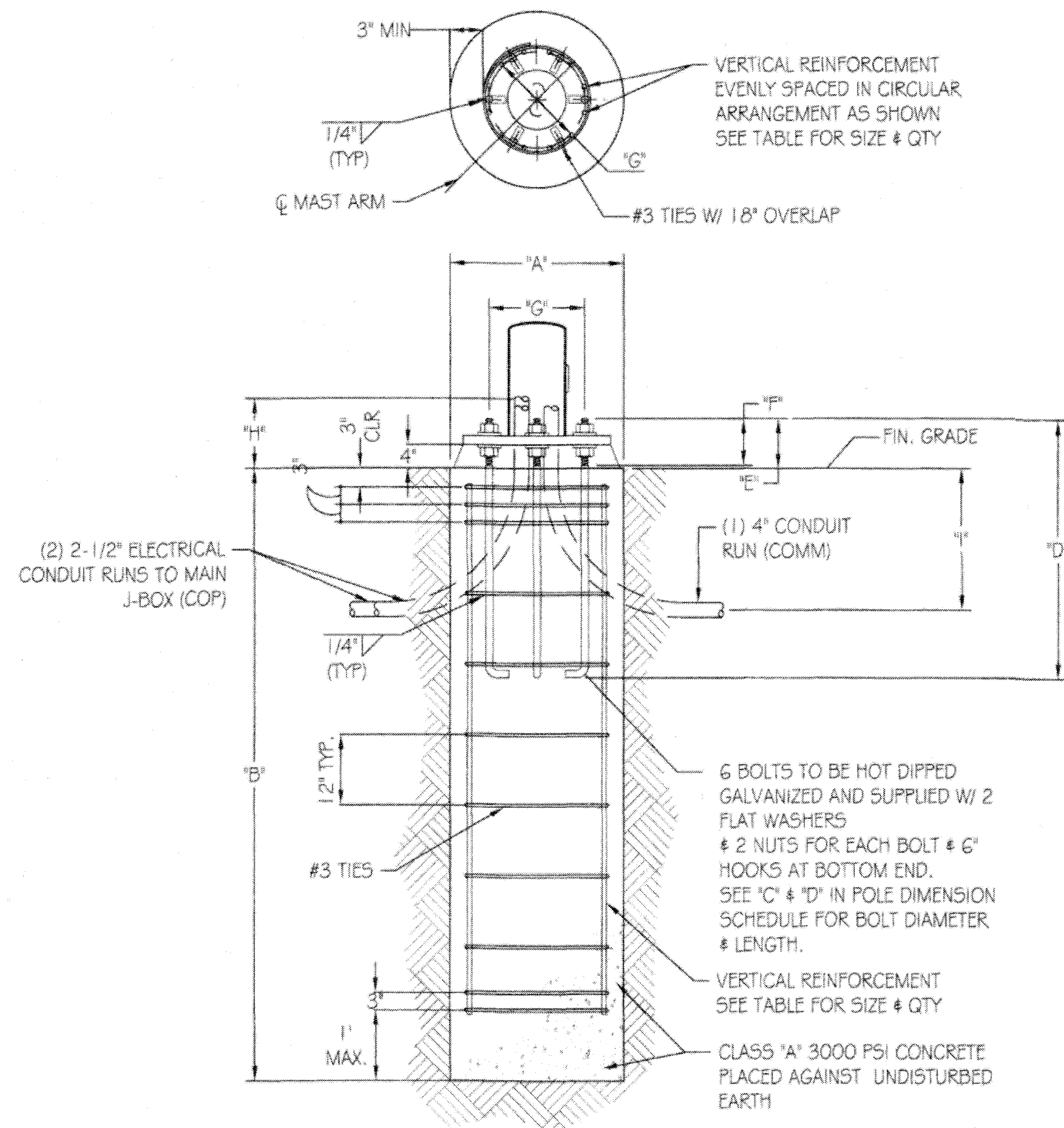

FOUNDATION, ANCHOR BOLT & REBAR CAGE DETAIL

FOUNDATION POLE TYPE	POLE DETAIL (ft.)		FOUNDATION DETAIL (in.)		VERT. REINFORCEMENT		BOLT DETAIL (in.)						* CONDUIT DETAIL		
	POLE HEIGHT	MAST ARM LENGTH	'A' WIDTH	'B' DEPTH	REBAR QUANTITY	REBAR SIZE	ASTM MATERIAL GRADE	'C' DIAMETER	'D' LENGTH OVERALL	'E' PROJECTION	'F' THREAD	'G' BOLT CIRCLE	'H' CLEAR	'I' MIN. DEPTH	CONDUIT QUANTITY
'SR' COMM POLE	32	15-50	36	138	12	#6	F1554-55	1-3/4	66	8 1/2	10	18	12	24	2 C.O.P. 1 COMM
			30	168	10	#6									

* CONDUIT SHALL ENTER 24" MINIMUM DEPTH, VERTICALLY, THROUGH THE BOTTOM OF THE FOUNDATION

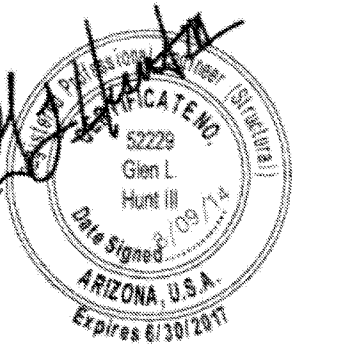

PROGRESS LOG	
0	8/9/14 ISSUED TO CLIENT
SHEET NUMBER	PROGRESS
S2	0
DRAWING DATE	
August 09, 2014	

CITY OF PHOENIX
 'SM' COMM SIGNAL POLE
 POLE DETAILS

MAST ARM STAGE PIPE DIAMETER		
PRIMARY MAST ARM LENGTH	COLUMN A	COLUMN B
15'	6 5/8" O.D. X 0.188 X 6'-4" (42 KSI)	6 5/8" O.D. X 0.156 X 6'-0" (42 KSI)
25'	6 5/8" O.D. X 0.188 X 13'-4" (56 KSI)	6 5/8" O.D. X 0.156 X 8'-0" (56 KSI)

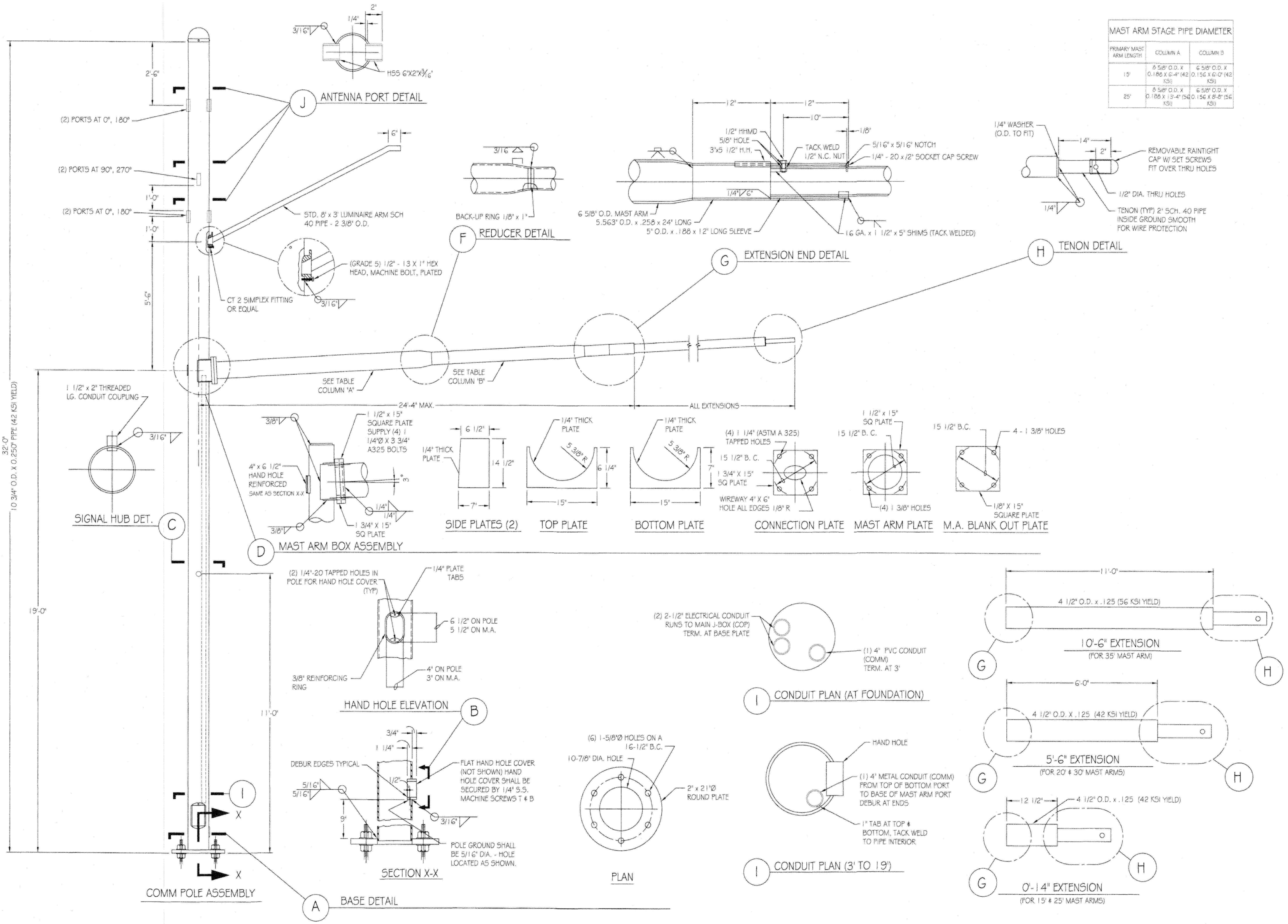

PROGRESS LOG	
0 8/6/14	ISSUED TO CLIENT
SHEET NUMBER	PROGRESS
S1	0
DRAWING DATE	
August 09, 2014	

CITY OF PHOENIX
 'SM' COMM SIGNAL POLE
 FOUNDATION DETAILS

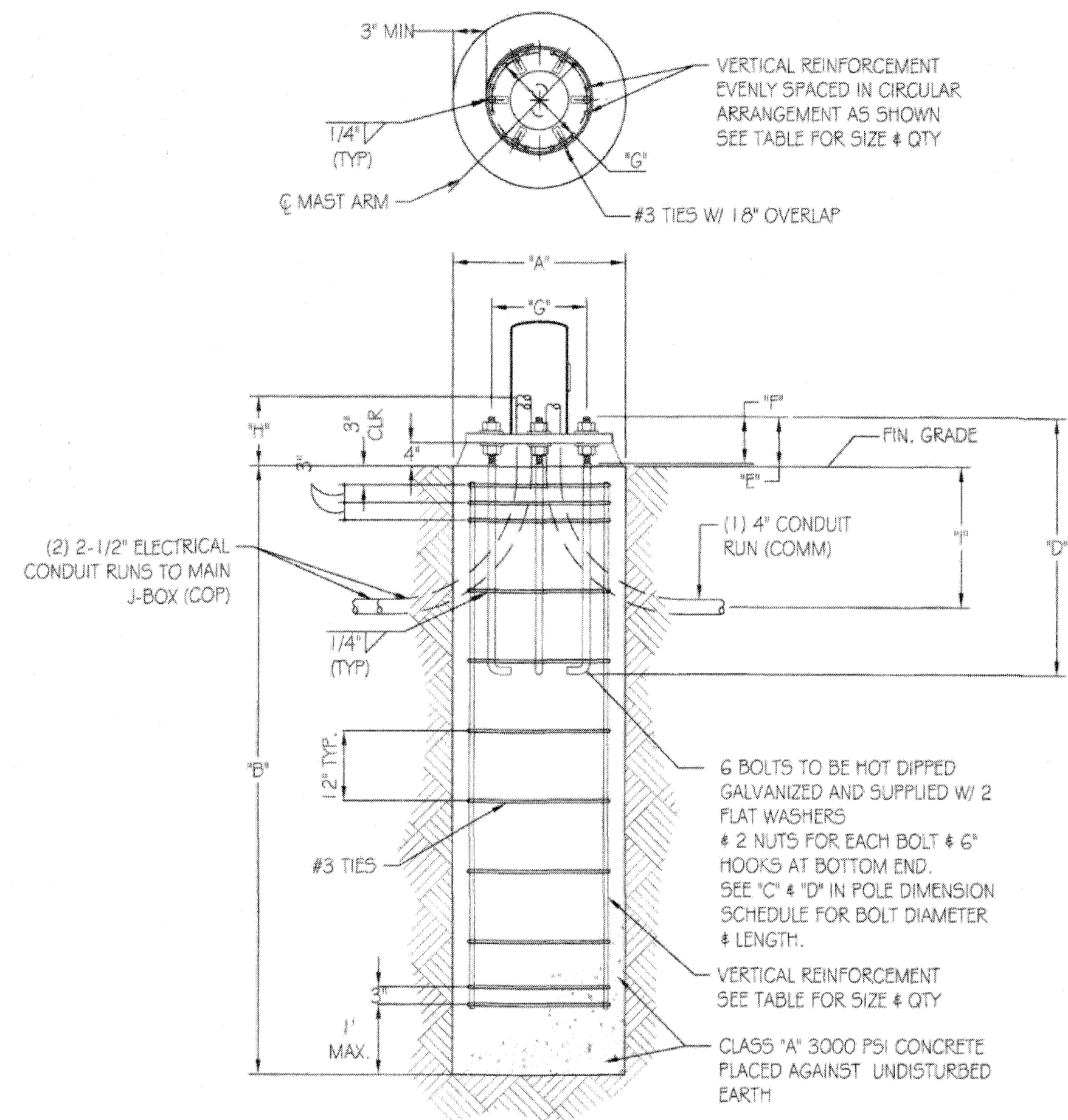

FOUNDATION, ANCHOR BOLT & REBAR CAGE DETAIL

FOUNDATION POLE TYPE	POLE DETAIL (ft.)		FOUNDATION DETAIL (in.)		VERT. REINFORCEMENT		BOLT DETAIL (in.)						* CONDUIT DETAIL		
	POLE HEIGHT	MAST ARM LENGTH	'A' WIDTH	'B' DEPTH	REBAR QUANTITY	REBAR SIZE	ASTM MATERIAL GRADE	'C' DIAMETER	'D' LENGTH OVERALL	'E' PROJECTION	'F' THREAD	'G' BOLT CIRCLE	'H' CLEAR	'I' MIN. DEPTH	CONDUIT QUANTITY
COMM POLE	32	15-35	36	120	12	#6	F1554-55	1 1/2	54	8 1/2	8	16 1/2	12	24	2 C.O.P.
			30	132	10	#6									1 COMM

* CONDUIT SHALL ENTER 24" MINIMUM DEPTH, VERTICALLY, THROUGH THE BOTTOM OF THE FOUNDATION

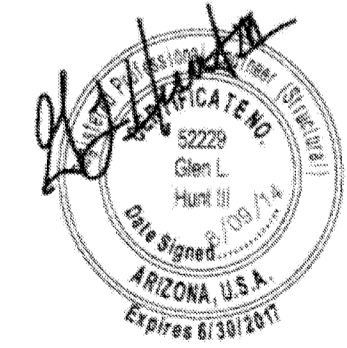

PROGRESS LOG	
8/9/14	ISSUED TO CLIENT
SHEET NUMBER	PROGRESS
S2	0
DRAWING DATE	
August 09, 2014	

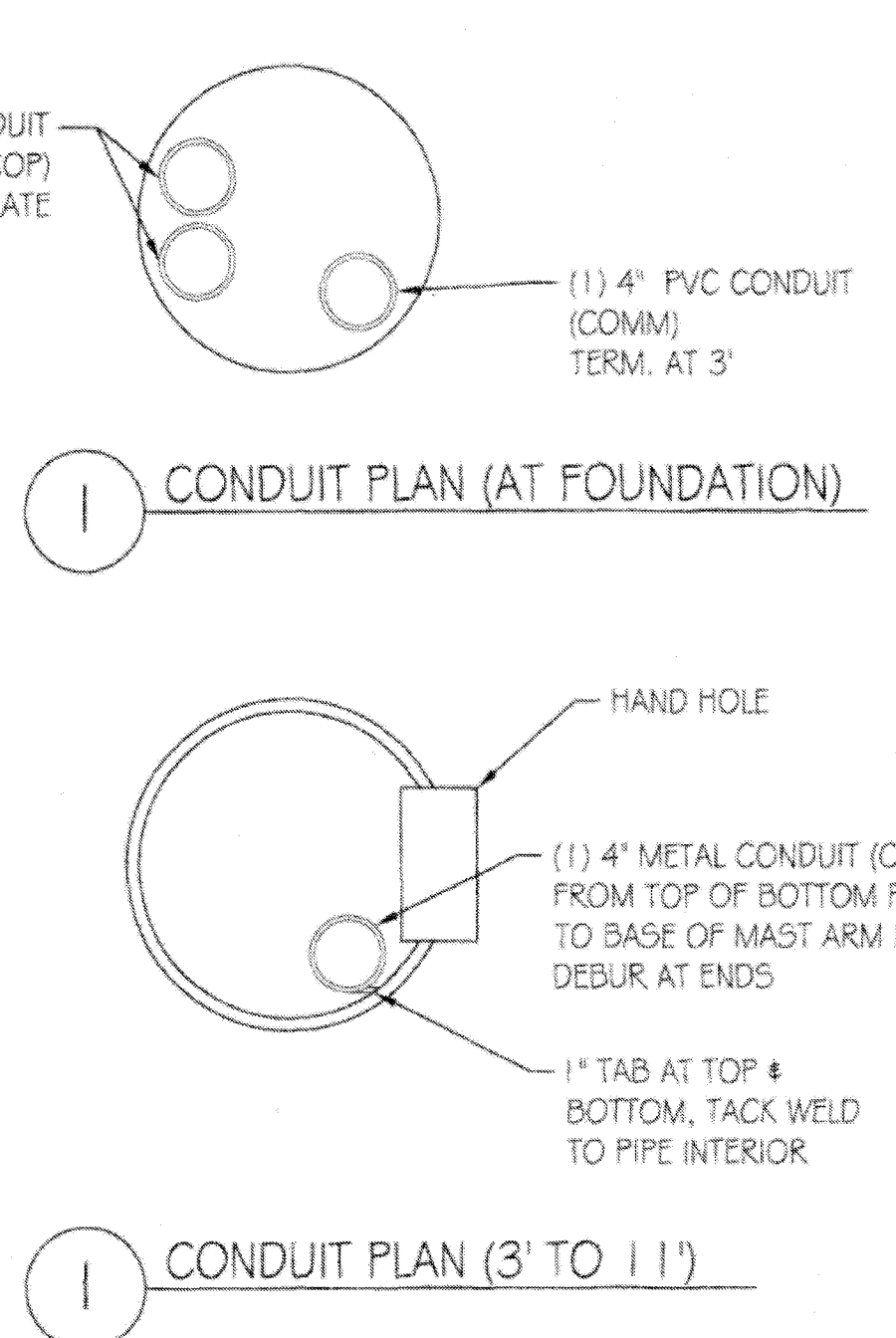
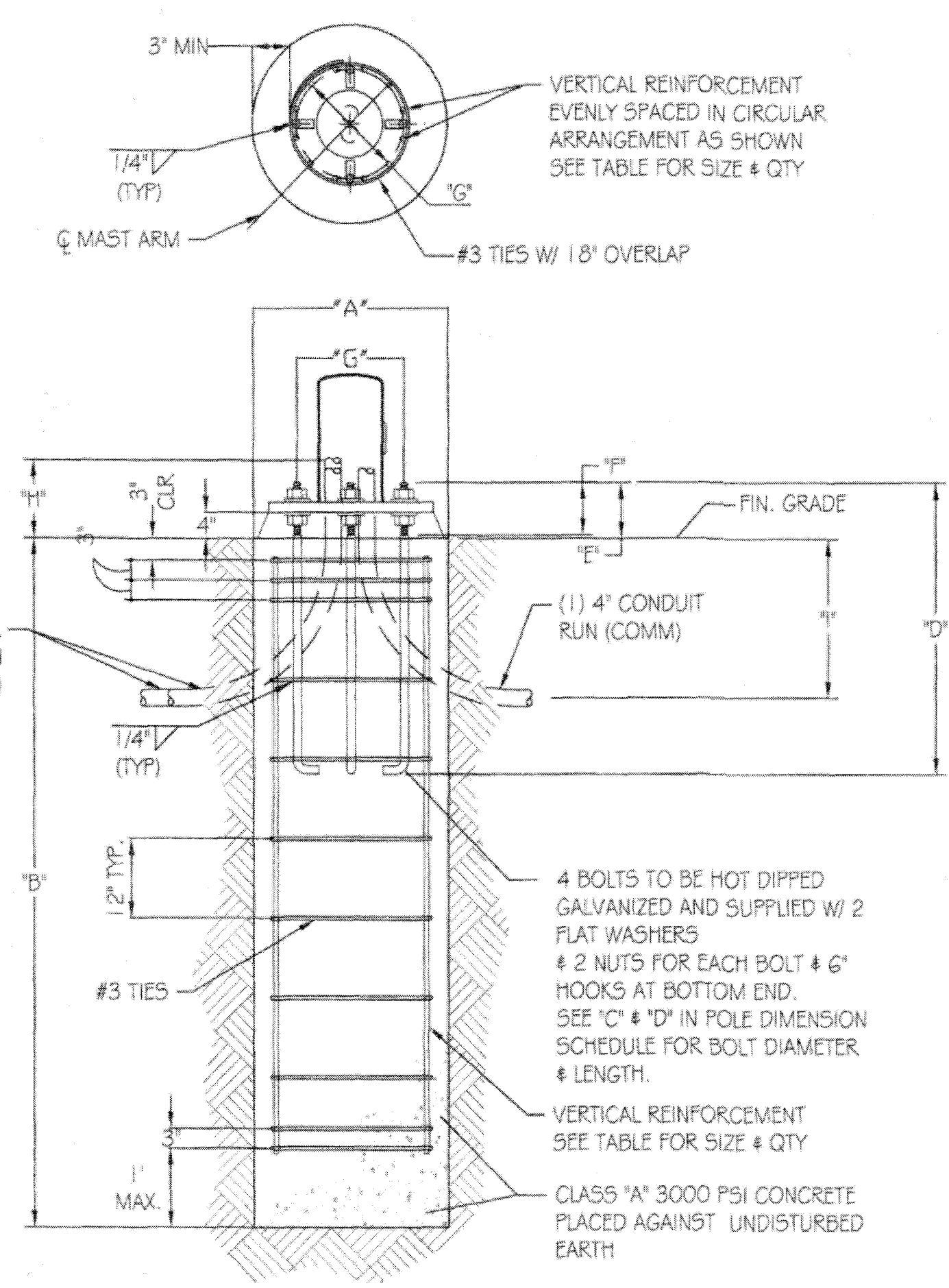
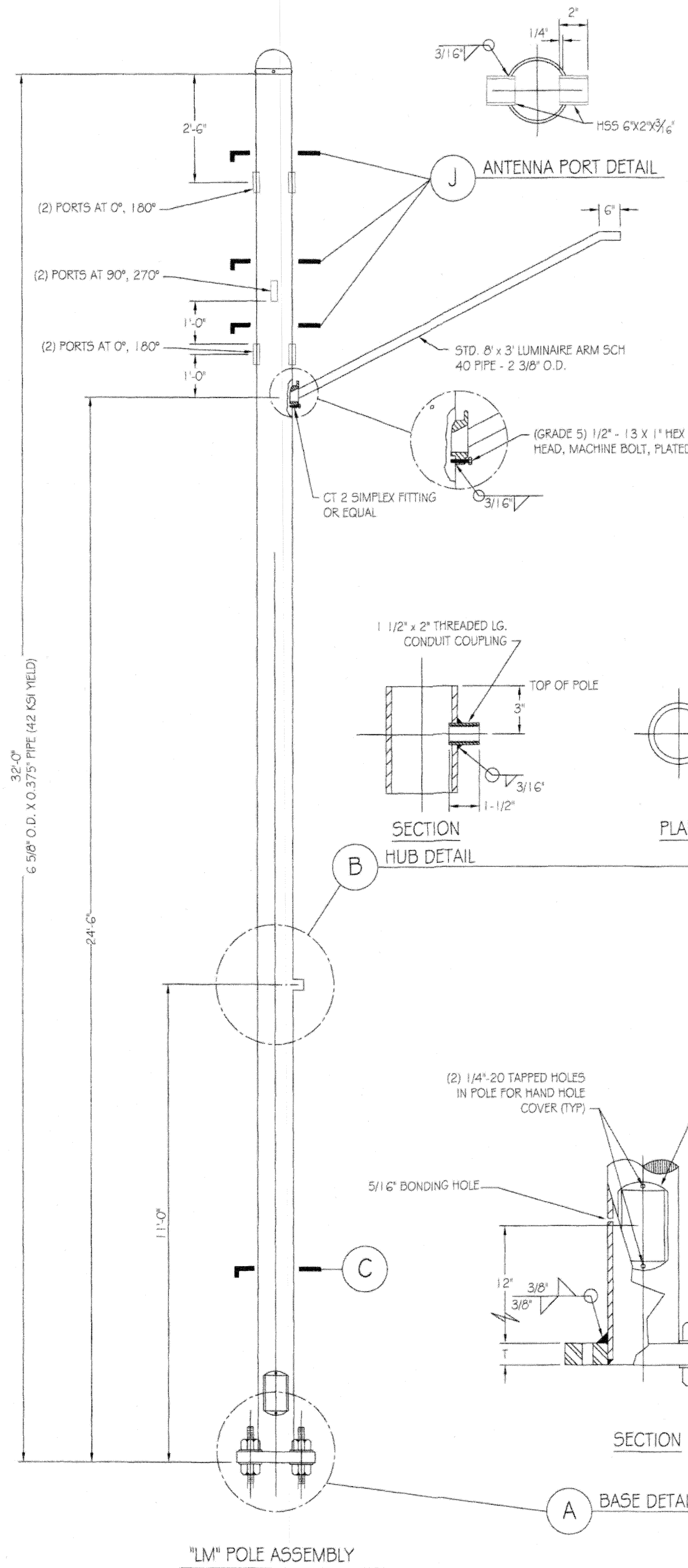

FOUNDATION POLE TYPE	POLE DETAIL (ft.)		FOUNDATION DETAIL (m.)		VERT. REINFORCEMENT		BOLT DETAIL (m.)						* CONDUIT DETAIL		
	POLE HEIGHT	MAST ARM LENGTH	'A' WIDTH	'B' DEPTH	REBAR QUANTITY	REBAR SIZE	ASTM MATERIAL GRADE	'C' DIAMETER	'D' LENGTH OVERALL	'E' PROJECTION	'F' THREAD	'G' BOLT CIRCLE	'H' CLEAR	'I' MIN. DEPTH	CONDUIT QUANTITY
TYPE "LM"	32	N/A	36	96	12	#6	F1554-55	1-1/4	44	7	6	10 1/2	12	24	2 COP
			24	108	8	#5									1 COMM

* CONDUIT SHALL ENTER 24" MINIMUM DEPTH, VERTICALLY, THROUGH THE BOTTOM OF THE FOUNDATION

verizon wireless
126 W. GEMINI DR.
TEMPE, AZ 85283

ISE Incorporated
Structural Engineers
P.O. BOX 50039
Phoenix, Arizona 85076
PHONE: 602-403-8614
www.ise-inc.biz

ISE JOB #: 8344

CITY OF PHOENIX
"LM" COMM SIGNAL POLE
POLE & FOUNDATION DETAILS

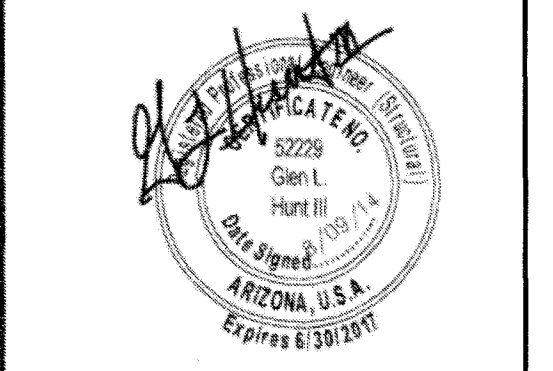

PROGRESS LOG	
0	8/6/14 ISSUED TO CLIENT
SHEET NUMBER	PROGRESS
S1	0
DRAWING DATE	
August 09, 2014	