



GREATER PHOENIX METRO GREEN INFRASTRUCTURE HANDBOOK

LOW-IMPACT DEVELOPMENT DETAILS FOR
ALTERNATIVE STORMWATER MANAGEMENT

JANUARY 2019

Prepared for



in Collaboration
with



and Member
Communities

Greater Phoenix Metro Green Infrastructure HANDBOOK

Low-Impact Development Details for Alternative Stormwater Management

Prepared for



With funding from



By the team of



L O G A N S I M P S O N

*Cover Image Credit: Marion Brenner
Scottsdale Museum of the West
Landscape Architecture by Colwell Shelor*

ACKNOWLEDGEMENTS

SCOTTSDALE CITY COUNCIL

Mayor W.J. "Jim" Lane
Councilwoman Suzanne Klapp
Councilmember Virginia Korte
Councilwoman Kathy Littlefield
Councilwoman Linda Milhaven
Councilman David N. Smith
Councilman Guy Phillips

SCOTTSDALE CITY MANAGER

Jim Thompson

SCOTTSDALE PROJECT MANAGER

Tim Conner

ORGANIZING PARTNER

ASU Sustainable Cities Network
Green Infrastructure Workgroup
Specs & Standards Subcommittee

SPECS & STANDARDS CORE TEAM

Tim Conner, City of Scottsdale
Leigh Padgitt, City of Phoenix
Harry Cooper, Flood Control District of Maricopa County
Anne Reichman, ASU Sustainable Cities Network

GRANTORS

Arizona Department of Environmental Quality
Trevor Baggiore, Edwina Vogan, & Jade Dickens
Water Infrastructure Finance Authority of Arizona
Sara Konrad, Trish Incognito, & Brandon Nguyen

CONSULTANTS

Dibble Engineering
Logan Simpson

REVIEW TEAMS & TEAM LEADERS

City of Apache Junction
Sam Jarjice
Flood Control District of Maricopa County
Harry Cooper
City of Glendale
Monica Rabb
City of Goodyear
David Ramirez
City of Mesa
Laura Hyneman
City of Phoenix
Leigh Padgitt
City of Scottsdale
Tim Conner
City of Tempe
Christina Hoppes
ASU Sustainable Cities Network
Anne Reichman

OTHER SUPPORTING CITIES

City of Avondale
City of Gilbert
City of Peoria

ACRONYM LIST

AASHTO	American Association of State Highway and Transportation Officials	MAG	Maricopa Association of Governments <i>(Uniform Standard Specifications and Details for Public Works Construction, 2018 Revision to the 2015 Edition)</i>
AMA	Active Management Area	MPH	Miles Per Hour
ASTM	American Society for Testing and Materials	NRMCA	National Ready Mix Concrete Association
ASCE	American Society of Civil Engineers	PSI	Pounds Per Square Inch
ADA	Americans with Disabilities Act	PPM	Parts Per Million
ADEQ	Arizona Department of Environmental Quality	SCN	Sustainable Cities Network
ASU	Arizona State University	TSDS	Technical Standard Details and Specifications
BMP	Best Management Practice	UofA	University of Arizona
BSM	Bioretention Soil Media	WIFA	Water Infrastructure Finance Authority
CPI	Concrete Pavement Institute		
ESAL	Equivalent Single Axle Load		
°F	Fahrenheit		
FCDMC	Flood Control District of Maricopa County		
FPS	Feet Per Second		
GI	Green Infrastructure		
ICPI	Interlocking Concrete Pavement Institute		
LID	Low Impact Development		



*Location: ASU Polytechnic Campus
Credit: FCDMC*

TABLE OF CONTENTS

PARTNERS	i	4. STORMWATER HARVESTING BASINS ... 31	9. DOMED OVERFLOW STRUCTURE 57
ACKNOWLEDGMENTS	ii	4.1 Applicability and Advantages.....	9.1 Applicability and Advantages.....
ACRONYM LIST	iii	4.2 Design Considerations.....	9.2 Design Considerations.....
TABLE OF CONTENTS	iv	4.3 Construction Considerations.....	9.3 Construction Considerations.....
SECTION 1: INTRODUCTION	1	4.4 Maintenance.....	9.4 Maintenance.....
INTRODUCTION	1	4.5 Compatibility with Other LID Practices.....	9.5 Compatibility with Other LID Practices.....
HYDROLOGIC DESIGN ANALYSIS	3	4.6 Specifications.....	9.6 Specifications.....
OVERVIEW OF THE SELECTION	4	5. VEGETATED OR ROCK BIOSWALE 35	SECTION 3: LANDSCAPE DETAILS & SPECIFICATIONS 60
GENERAL NOTE	5	5.1 Applicability and Advantages.....	GEOLOGIC SETTING
MARICOPA ASSOCIATION OF GOVERNMENTS	6	5.2 Design Considerations.....	SOILS
SECTION 2: DETAILS & SPECIFICATIONS 7		5.3 Construction Considerations.....	PLANT PALETTE
1. PERMEABLE PAVEMENTS	7	5.4 Maintenance.....	MAINTENANCE
1.1 Applicability and Advantages.....	8	5.5 Compatibility with Other LID Practices.....	RECOMMENDATIONS AND GUIDELINES ... 62
1.2 Design Considerations.....	9	5.6 Specifications.....	RECOMMENDATIONS
1.3 Hydrologic Function.....	9	6. BIORETENTION SYSTEMS 41	SPECIFICATIONS
1.4 Structural Design Requirements.....	10	6.1 Applicability and Advantages.....	GUIDELINES
1.5 Underdrains.....	11	6.2 Design Considerations.....	GLOSSARY
1.6 Construction Considerations.....	11	6.3 Construction Considerations.....	REFERENCES
1.7 Maintenance.....	11	6.4 Maintenance.....	APPENDICES
1.8 Compatibility with Other LID Practices.....	11	6.5 Compatibility with Other LID Practices.....	A. Rain Gauge Measurements.....
2. CURB OPENINGS	23	6.6 Specifications.....	B. Rainfall Tables.....
2.1 Applicability and Advantages.....	24	7. CURB EXTENSION 47	C. Additional Plant Lists.....
2.2 Design Considerations.....	24	7.1 Applicability and Advantages.....	
2.3 Construction Considerations.....	24	7.2 Design Considerations.....	
2.4 Maintenance.....	24	7.3 Construction Considerations.....	
2.5 Compatibility with Other LID Practices.....	24	7.4 Maintenance.....	
2.6 Specifications.....	24	7.5 Compatibility with Other LID Practices.....	
3. SEDIMENT TRAPS	27	7.6 Specifications.....	
3.1 Applicability and Advantages.....	28	8. BIORETENTION PLANTER 51	
3.2 Design Considerations.....	28	8.1 Applicability and Advantages.....	
3.3 Construction Considerations.....	28	8.2 Design Considerations.....	
3.4 Maintenance.....	28	8.3 Construction Considerations.....	
3.5 Compatibility with Other LID Practices.....	28	8.4 Maintenance.....	
3.6 Specifications.....	29	8.5 Compatibility with Other LID Practices.....	
		8.6 Specifications.....	
			LIST OF TABLES
			Table 1. Application of Permeable Pavers.....
			Table 2. Operation and Maintenance Tasks for Permeable Pavements.....
			Table 3. Base Course Gradation.....
			Table 4. Recommended Depth of Bioretention Media to Target Pollutant of Concern.....
			Table 5: Compost.....

SECTION 1 - INTRODUCTION

PURPOSE OF THE HANDBOOK

The purpose of this Handbook is to provide members of the design, planning, and development communities in Maricopa County, Arizona with guidance and specific techniques for low impact development (LID) that can be implemented on their projects. The Handbook is intended to address non-point source pollutant load reductions, conformance with first-flush requirements, and stormwater peak flow and volume reductions for water quality and flood hazard mitigation benefits within the Salt and Gila rivers, specifically, and the Middle Gila Watershed in general. Equally important in the Sonoran Desert is the opportunity to ameliorate water supply/demand concerns by increasing rainfall infiltration, recharging groundwater, and harvesting stormwater to offset potable water used for outdoor purposes.

The goal of this Handbook is to advance the implementation of LID and green infrastructure (GI) by developing selected LID technical standard details and specifications (TSDS). These TSDS are expected to be used primarily on public projects associated with road and street improvements, although the concepts and techniques are equally applicable to private projects. Ultimately, it is anticipated these TSDS, or improved versions of these TSDS, will be incorporated into the design and development standards of communities across Maricopa County.

LID TSDS have several identifiable environmental benefits. Utilizing LID practices can reduce the amount of runoff and stormwater conveyed through the existing conveyance systems of Phoenix-area communities, which will directly translate to reductions in the amount of pollutants that are discharged into the Middle Gila Watershed. Pollutants can be filtered naturally by increasing runoff infiltration into soils through LID installations. Additionally, implementation of LID practices can result in the beneficial use of stormwater as a supplemental source of landscape irrigation.



*Location: Scottsdale's Museum of the West
Credit: Marion Brenner*

Community and secondary benefits include overall water conservation, urban heat reduction, improvements in population health, and the aesthetic benefits of additional green spaces.

BACKGROUND

When introduced by Maryland's Prince George's County in 1999, LID was a radically different approach to stormwater management. It was developed to address issues related to new residential, commercial, and industrial development through reimagined environmental design and implementation practices. As originally conceived, the LID approach combined a hydrologically effective and integrated design that incorporated site-scale pollution prevention measures to compensate for land development impacts on hydrology and water quality. LID was intended to recreate natural (pre-construction) hydrologic patterns by utilizing landscaping and collection techniques that store, absorb, infiltrate, evaporate, and detain runoff throughout a site to keep as much rainwater as possible onsite near the location where it landed. This differed significantly from the prevailing approach at that time, in which stormwater was shed from a site as efficiently as possible through structural methods.

The objectives of the LID approach are accomplished by:

- Minimizing stormwater impacts to the extent practicable. Techniques include reducing imperviousness, conserving natural resources and ecosystems, maintaining natural drainage courses, reducing the use of pipes and structural collection systems, and minimizing clearing and grading.
- Providing dispersed runoff storage measures throughout a site using a variety of detention, retention, and runoff practices.
- Maintaining predevelopment times of concentration by strategically routing flows to maintain travel times and to control the discharge.
- Implementing an effective public education program to encourage property owners to use pollution prevention measures and to maintain LID management practices on their sites.

Since its introduction, LID has gained wide acceptance nationally and has been extensively practiced in the eastern and northwestern portions of the United States. It is integral to land planning and development criteria in that part of the country because of the higher rainfall, greater potential for pollution via runoff, and the obvious need

for a higher level of stormwater management. In Arizona, the City of Tucson and Pima County have championed and implemented LID and/or water harvesting for many years. In the Phoenix Metropolitan Area and other areas of Arizona, receptivity to and interest in LID has been minimal until the last few years. There is newfound interest in LID practices in central Arizona for a variety of reasons. These include greater visibility of the concept through outreach efforts by a variety of organizations and entities, rising infrastructure and water costs, and higher public consciousness about the scarcity of water in the Southwest. There is also a recognition by local design and planning professions and community leaders that LID is a sustainable approach that can be adapted for use in the Sonoran Desert through thoughtful consideration.

Some of the original techniques conceived by Prince George's County are not applicable because of our Sonoran Desert setting. The basic concepts of working with natural patterns, reducing impervious surfaces, capturing stormwater and pollutants, reliance on vegetation to absorb stormwater, dispersed on-site capture locations to keep rainwater near where it falls on the ground, minimizing pipes, etc. are all valid and implementable in central Arizona.



*Location: Gateway Community College
Credit: Leigh Padgitt*

HYDROLOGIC DESIGN ANALYSIS

The rainfall characteristics of the Desert Southwest are very different from many other climates based on research conducted by the University of Arizona (U of A) as published in Pima County's 2015 Low Impact Development and Green Infrastructure Guidance Manual (Reference 1). High-intensity, short-duration thunderstorms occur frequently during the monsoon—typically occurring in July through September; dissipating tropical storms may travel over the area during some years during the fall; and lower-intensity, frontal storms often occur during winter months. A frontal storm develops at the boundary or front of two different masses of air and depends less on the season of the year as compared to the monsoon storms.

In general, Arizona's rainfall seasons are often separated by prolonged periods of dry conditions with low humidity.

Data from more than 4,700 rainfall events in Pima County were recorded by the U of A between 1895 and 2000. An average of 45 rainfall events per year occurred during this period. Of those, approximately 40 percent produce 0.1 inch or less of precipitation, and approximately 85 percent of all events had less than 0.5 inch. Because the 85 percent rainfall event (< 0.5 inch) has been identified by the American Society of Civil Engineers (ASCE 1998) as the most appropriate event for capturing rainfall for stormwater mitigation, Maricopa County has chosen this 0.5-inch event as a minimum threshold for first-flush retention (Reference 2). The first-flush rainfall was selected because this is the amount of rainfall that collects the highest amounts of pollutants.

The results indicate that very small events, such as those of less than 0.1 inch, contribute very little to runoff from a site, because most of the precipitation is eliminated by the initial abstraction or infiltrated into the dry soils. Rainfall events with depths between 0.3 and 0.5 inches are frequent enough and large enough to produce the majority of the average annual runoff volume from a site.

The analysis of annual peak daily rainfall from the U of A data shows that rainfall depths greater than 1.5 inches are fairly infrequent. Since these large events cause floods, designing systems to mitigate the impacts will be beneficial to the surrounding lands and/or development (however, just meeting this criteria may not satisfy the regulatory [i.e., 100-year] flood-event requirements). Nonetheless, analysis of the U of A rainfall data indicates that stormwater systems and individual features should be designed to accommodate rainfall events between 0.5 and 1.5 inches. Because the TSDS identified in this Handbook are also intended to be used in locations with possibly limited rights of way (ROWs), the rainfall volume considered throughout this document is 0.5 inches. It is recognized that the TSDS can be sized to accommodate larger rainfall volumes; a maximum value of 1.25 inches is recommended for the maximum design storm depth if larger facilities are planned.

HYDROLOGIC DESIGN REQUIREMENTS

Rainfall information from 319 Flood Control District of Maricopa County (FCDMC) rain gauges was collected and analyzed for this Handbook. Many of these gauges have been in service since 1982. The analysis revealed that 90 to 95 percent of all storms were below 1.5 inches depending on the rainfall gauge location, which is an ideal rainfall amount for designing the maximum storage capability of LID systems in Maricopa County. Rainfall events less than the first flush rainfall, which is typically the first 0.5 inches of rainfall, occurred on 82 percent of all the storms recorded at all gauge locations. The first flush rainfall is the design criteria used in this Handbook. The rainfall analysis has been included in Appendix A.



Location: ASU Taylor Mall
Credit: Leigh Padgett

OVERVIEW OF THE SELECTION PROCESS FOR THE TOP 10 TECHNICAL STANDARD DETAILS AND SPECIFICATIONS

Arizona State University's (ASU's) Sustainable Cities Network (SCN) has been critical to the development of this LID Handbook. Since 2009, SCN has consistently convened Phoenix-area communities on important, local sustainability topics, including green infrastructure (GI) and urban forestry. As the first university-city sustainability network of its kind in the US, SCN engages with Arizona cities, towns, tribal communities, counties, government agencies, and other public and private partners to further local and regional sustainability, and engage communities with ASU students, faculty, and innovative research. Through SCN's GI Workgroup, municipalities and interested stakeholders actively discuss challenges and opportunities for expanding how GI techniques like LID can be more widely used throughout the Phoenix area. With SCN's guidance; through the hard work of the core members of SCN's Specs & Standards Subgroup (including the cities of Scottsdale and Phoenix and FCDMC); and with the efforts of municipal review teams, the idea of a LID handbook geared toward the area's unique environment took shape.

To help make the Handbook a reality, the City of Scottsdale acquired grant funding to develop the Greater Phoenix Metro Green Infrastructure Handbook from the Arizona Department of Environmental Quality (ADEQ) 604(b) grant program, as well as monies from the Water Infrastructure Finance Authority (WIFA) Technical Assistance Fund. The City of Scottsdale also contributed funding and project and grant management.

The purpose of this project is the development of 10 LID TSDS. A data-collection effort was completed that produced several alternatives that were presented to a stakeholder group made up of eight Phoenix Metropolitan Area municipal representatives. These alternatives were ranked by the stakeholder groups. The results were tabulated and then reviewed by a core team, including representatives from the City of Scottsdale, City of Phoenix, FCDMC, and SCN.



Location: Scottsdale's Museum of the West
Credit: Colwell Shelor

GENERAL NOTES OF CONSIDERATION FOR ALL LID DETAILS

The TSDS presented in this Handbook are the initial generation of standards and have been prepared to be modified (as necessary) in the future based on user feedback about materials, construction, and/or performance based on conventional monitoring of the installations.

An analysis of local soils and percolation rates will be required to determine if subgrade soils will percolate as necessary and if structured soils, over-excavation, and/or specifically designed backfill are required.

An evaluation of underground utilities should be carried out prior to design.

Additional engineering or the use of provided calculations may be needed to appropriately size detention facility flow velocities, and in some cases, structural bearing capacities.

If there are subsurface infiltration restrictions like poorly draining soils, caliche, bedrock, soil contamination, or moisture-sensitive adjacent structures as identified during geotechnical investigations, the TSDS shown in this Handbook may not be recommended without augmentation.

These conditions may require the TSDS be modified to include features such as impermeable membranes to prevent undesirable underground migration. Another option is to create an enclosed detention system, or to incorporate an underdrain collector connected to an appropriate downstream drainage facility, LID element, and/or underground stormwater collection system. Each designer will need to determine, if any, the types of additional features that are necessary to ensure the proper function of the GI elements and to protect potentially affected resources.

To avoid the potential risk of off-site properties and resources, LID elements should be located at least:

- 10 feet offset from buildings and building foundations
- 10 feet from property lines
- 150 feet from water supply wells
- 50 feet from septic systems

Note: *The above dimensions are considered minimums; the actual dimensions shall be determined through geotechnical studies and engineering evaluations.*

The details may require modifications for adequate sediment and erosion control.

The provision of an appropriate maintenance plan for each detail type and unique site features will be required. The maintenance plan may differ from current practices and vary from detail to detail.

Proper percolation or underground storage infiltration must be designed for vector control.

For several of the LID elements, landscaping is integral to function and aesthetics. Incorporating landscaping slows the stormwater, which increases water infiltration and absorption. Landscaping can decrease the reliance on potable water for irrigating the plants, depending on the landscape design and the volume and pattern of stormwater collection.

Where feasible, it is preferred that the TSDS surface treatments consist of landscaping, seeding, organic materials (e.g., wood mulch) or other natural, moisture-retaining products. Similar materials can also be incorporated into the bioretention soil media (BSM) of the TSDS to aid in holding moisture conveyed to the LID element.



*Location: Manzanita Park
Credit: Leigh Padgitt*

MARICOPA ASSOCIATION OF GOVERNMENTS

MAG is a Council of Governments that serves as a regional planning agency for in the Phoenix Metropolitan Area. MAG is made up of 27 cities and towns, three Native American communities, Maricopa County, and portions of Pinal County. MAG was founded in part to ensure maximum efficiency and economy in governmental operations. MAG's Public Works Program was established to standardize infrastructure construction throughout the region by coordinating the building codes and construction specifications and details used by member agencies. These TSDS were developed to be used in association with MAG's Uniform Standard Specifications and Details for Public Works Construction (Standards) to ensure that construction is cost-effective and meets safety and quality standards. Under this program, MAG makes its Standards available online and through purchase. These materials are used by MAG members, as well as the private construction industry within MAG communities, as the base construction standards for building a wide variety of infrastructure-related improvements. The MAG Standards have some unique aspects that are useful to understand when reviewing the TSDS included in this Handbook.

The Standards include a definition of the terms used, the materials to be used, steps to be taken, and performance requirements to be met by the finished construction. The construction details in the Standards are a series of technical drawings showing a graphical representation of the feature(s) to be

built, with tables, charts, notes, and references back to the specifications. The specifications and details are broken into sections of related construction work in a numbered sequence with periodic gaps to allow for the incorporation of new standards.

While intended to be standards for municipalities in the MAG region, the specifications and details can be changed by the agencies on a project-by-project or city-wide basis to reflect local preferences and practices; for improved functionality (e.g., greater capacity); funding constraints; site conditions (e.g., expansive soils); and/or for other reasons. Typically, the project-based changes to the Standards occur as "add," "delete," "replace with," and "modify to" the MAG specifications and details as described and shown in the project-specific drawings and specifications. City-wide modifications to the MAG Standards are published by those agencies as supplements to the MAG Standards and are made available to the design and construction industry by those communities.

A unique aspect of the MAG specifications is that construction work is generally defined and specified primarily by activity rather than a completed item of work. For example, building a road is specified in several specification sections. Excavating or grading the roadbed is addressed in Section 205. Placing the subbase material is in Section 310. Placing the asphalt is in Section 321. All landscape-related work is specified in Section 430.

The MAG format also allows for specifying complete items of work (such as for installation of a street light pole), similar to how some of the TSDS specifications are proposed in this Handbook. In the design and construction industry, these are known as "bid item" specifications. This approach allows for placing all of the requirements for the work related to installing a street light pole, for instance, in a single location. When using a bid-item specification approach, it is customary to refer to existing MAG specification sections or details, rather than repeating them entirely within the bid-item specification. When you read "refer to MAG Section 203 for subgrade preparation requirements," it should be understood by the reader that Section 203 currently exists in the Standards, and it contains requirements that are applicable to the item of work being described.

The user would need the TSDS descriptions and the referenced MAG Standards to fully understand the requirements for the item being specified. Because the current Standards do not include all of the TSDS in this Handbook, new section numbers have been created to incorporate them in accordance with the MAG numeric and activity structure. If "MAG" does not precede the specification, that indicates that it is a special provision developed for this Handbook and is not found in the MAG standards.

Digital versions of the TSDS in this Handbook can be found at <https://sustainability.asu.edu/sustainable-cities/resources/lid-handbook/>.

SECTION 2 - LID DETAILS AND SPECIFICATIONS

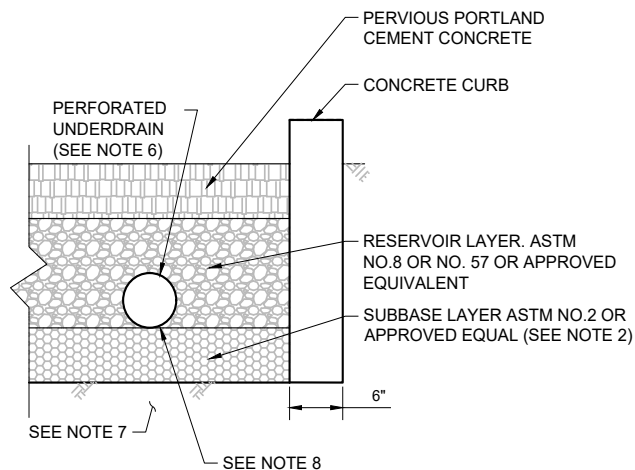

PERVIOUS CONCRETE

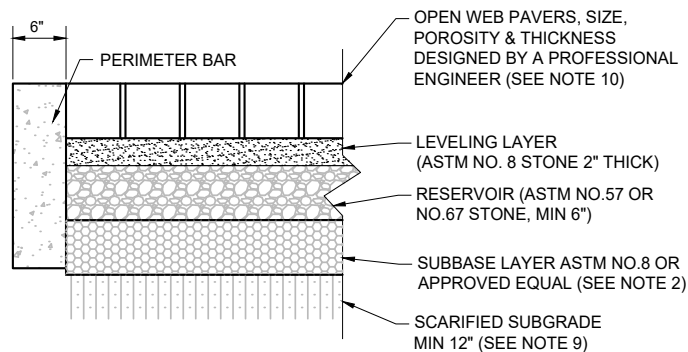

PERVIOUS CONCRETE PAVERS

NOTES:

1. AGGREGATE LAYERS SHALL MEET PROPOSED SPECIAL PROVISION 303.
2. GEOSYNTHETIC TO BE USED TO PROTECT PIPES FROM CLOGGING. SEE MAG SPECIFICATION 796.
3. DEPTH OF RESERVOIR LAYER AS SHOWN ON DESIGN PLANS SHOULD BE SIZED TO DRAIN WITHIN 72 HOURS.
4. TOP OF PAVEMENT SHOULD BE DESIGNED TO ACHIEVE 1% MAXIMUM SLOPE IN ANY DIRECTION.
5. WHEN FILTER LAYER IS OMITTED, PROVIDE GEOSYNTHETIC CLASS-A MATERIAL BENEATH RESERVOIR LAYER.
6. UNDERDRAIN REQUIRED FOR LOW PERCOLATING SOILS (SEE SPECIFICATION 622).
7. UNCOMPACTED SUBGRADE FOR AREAS DESIGNED FOR INFILTRATION FEATURES ONLY.
8. GEOSYNTHETIC MATERIAL (SEE SPECIFICATION 796)
9. COMPACTION REQUIREMENTS IF ANY WILL BE DESIGNED BY GEOTECHNICAL ENGINEER.
10. SOLID PAVERS CAN BE USED (OPTIONAL).
11. MINIMUM COVER OVER THE UNDERDRAIN PER MANUFACTURER RECOMMENDATION.

PERVIOUS CONCRETE PAVEMENT

PAVEMENT ITEM	MINIMUM PAVEMENT THICKNESS	
	CLASS A	CLASS B
PERVIOUS PORTLAND CEMENT CONCRETE	6"	8"
RESERVOIR LAYER	6", SEE NOTE 3	12", SEE NOTE 3
SUBBASE LAYER	4"	4"

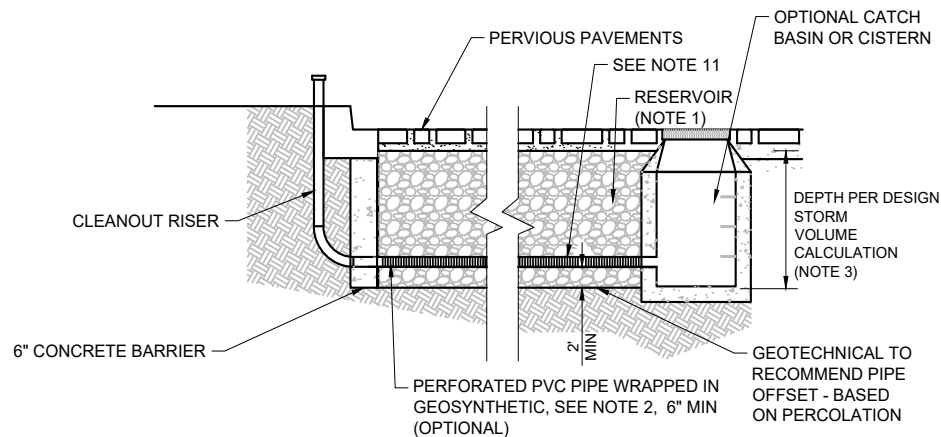

PERMEABLE PAVEMENT WITH UNDERGROUND RESERVOIR AND UNDERDRAIN (OPTIONAL)

DETAIL NO. LID-01	STANDARD DETAIL ENGLISH	PERMEABLE PAVEMENT	REVISED 01-29-2019	DETAIL NO. LID-01
-----------------------------	------------------------------------	---------------------------	-----------------------	-----------------------------

1. PERMEABLE PAVEMENTS

Permeable pavements (LID-01) are a highly versatile LID element because they can effectively reduce pollutants and can be integrated into site plans with various configurations and drainage elements. Permeable pavement allows streets, parking lots, sidewalks, and other impervious covers to utilize the infiltration capacity of underlying soils while maintaining the structural and functional features of the materials they replace, if retrofitted into an existing hardscape situation.

Permeable pavement has small voids or aggregate-filled joints that allow water to drain through to an aggregate reservoir. Stormwater stored in the reservoir layer can then infiltrate underlying soils or drain at a controlled rate through underdrains to other downstream stormwater control systems. Permeable

pavement systems can be designed to operate as underground detention if the native soils do not have sufficient infiltration capacity, or if infiltration is precluded by aquifer protection, contaminated soils, or adjacent structures.

Permeable pavement can be developed using modular paving systems (e.g., permeable interlocking concrete pavers, concrete grid pavers, or plastic grid systems) or poured-in-place solutions (e.g., pervious concrete). Some pervious concrete systems can also be precast. In many cases, especially where space is limited, permeable pavement is a cost-effective solution relative to other practices because it can double as both transportation infrastructure and as GI.

The components of a permeable pavement system, in general, should include a permeable paving surface and a reservoir material, such as a base layer of crushed aggregate. Liners, geotextiles, and underdrains can also be used with this LID feature.

1.1 APPLICABILITY AND ADVANTAGES

Permeable pavements are suitable for low- to moderate-vehicular use areas, such as parking lots, overflow parking areas, sidewalks, and access roads. Permeable pavements are currently not suitable for higher speed traffic (>30 mph) or areas designed for high structural loads. Table 1 shows the typical permeable pavement applications, which was developed in the Puget Sound LID Manual (Reference 3).

Table 1: Application of Permeable Pavers

Application	Residential Walk/Patio	Residential Driveway	Commercial Pedestrian Plaza	Emergency Access Lane or Overflow Parking	Parking Lot or Travel Lanes	Residential Street or Collector (<30 mph)	High Speed Highway (>30 mph)
Permeable Pavers	Yes	Yes	Yes	Yes	Yes	Yes	No
Pervious Concrete	Yes	Yes	Yes	Yes	Yes	Yes	No
Porous Asphalt	Yes	Yes	No	Yes	No	No	No
Grid Pavements	Yes	Yes	Yes	Yes	No	No	No

10 LID TECHNICAL STANDARD DETAILS AND SPECIFICATIONS

This LID element is **not recommended** in areas where higher pollutant loading is expected. Examples of high pollutant load areas are fueling stations, vehicle storage areas, or industrial process facilities. If this element is scheduled for installation at these types of facilities, appropriate pretreatment, such as an oil-water separator or a filtering device, must be provided, or the areas should be diverted from the permeable pavement. Infiltration barriers may also be required in these types of locations.

Permeable pavements advantages include:

- Reducing stormwater runoff rate and volume.
- Reducing loads of some pollutants in surface runoff by reducing the volume of stormwater leaving a site.
- Reducing stormwater infrastructure footprint and promoting multibenefit uses by capturing stormwater in parking/driving areas, which reduces project costs as compared to singular uses.
- Increasing groundwater recharge.
- Compatibility with retrofit projects.
- Many material choices and design options.
- The ability to utilize them in recharge zones, karst, expansive clays, and contaminated soil conditions, if properly designed.

1.2 DESIGN CONSIDERATIONS

Permeable pavements must be designed to achieve two aims:

- Support traffic loads.
- Manage surface water effectively (i.e. provide sufficient storage).

Other considerations that should be accounted for during the design of permeable pavements include:

- As with any pavement, Americans with Disabilities Act (ADA) requirements must be followed.

- To prevent clogging, decomposed granite should not be used with this facility or located adjacent to this facility.
- Specific structural design considerations may be needed to prevent rutting.
- Site-specific geotechnical information is needed.
- Soil conditions do not typically constrain the use of permeable pavement, although they do determine whether an underdrain is needed (also see discussion regarding underdrains). Infiltration may be promoted in these designs, however, by incorporating an infiltration sump (i.e., a layer of stone below the invert of the underdrain). When designing a permeable pavement practice, designers must verify soil permeability by using the locally-approved on-site soil investigation methods.

1.3 HYDROLOGIC FUNCTION

Permeable pavement systems are designed to reduce surface runoff by allowing stormwater to infiltrate the pavement surface. While the specific design can vary, most permeable pavements have a similar structure consisting of a surface course layer and an underlying stone aggregate reservoir layer. Modular underground storage units, chambers, and pipes can also be integrated for additional subsurface storage. Where soils permit, permeable pavement allows captured runoff to fully or partially infiltrate into underlying soils.

Volume reduction (stormwater capture) primarily depends on the drainage configuration and subsoil infiltration capacities. Systems installed without underdrains in highly permeable soils can achieve practically 100 percent volume reduction efficiency (Reference 4). Systems installed in restrictive clay soils can still give significant volume reduction (Reference 5 and 6). The volume reduction can be

further enhanced by treating the subgrade with scarification, ripping, or trenching as discussed in Impacts of Construction Activity on Bioretention Performance (Reference 7, Appendix B.5.2). Additional volume reduction can be done by incorporating an internal water storage layer by upturning underdrain inverts to create a sump (Reference 8). Peak flow can be also effectively attenuated by permeable pavement systems by reducing overall runoff volumes, promoting infiltration, and increasing the lag time to peak discharge (Reference 9).

If permeable pavement is used in a parking lot or another setting that involves vehicles, the pavement surface must be able to support the maximum anticipated traffic load. The structural design process will vary according to the type of pavement selected. The manufacturer's specific recommendations should be followed. The thickness of the permeable pavement and reservoir layer must be sized to support structural loads and to temporarily store the design storm volume. On most new development and redevelopment sites, the structural support requirements will dictate the depth of the underlying stone reservoir.

The structural design of permeable pavements involves considering four main site elements:

- Total traffic
- In-situ soil strength
- Environmental constraints
- Bedding and reservoir layer design

The resulting structural requirements can include the thickness of the pavement, filter, and reservoir layer. Designers should note that if the underlying soils have a low California Bearing Ratio (CBR) (less than 4 percent).

Designers should determine structural design requirements by consulting transportation design guidance sources, such as the following:

- American Association of State and Highway Transportation Officials (AASHTO) Guide for Design of Pavement Structures (Reference 10).
- AASHTO Supplement to the Guide for Design of Pavement Structures (Reference 11).

Designers should also review guidelines specific to the municipality where the permeable pavement is being designed.

1.4 STRUCTURAL DESIGN REQUIREMENTS

Some of the different kinds of permeable pavements and associated reservoir materials are described below.

1.4.1. PERMEABLE PAVERS

Permeable pavers interlock in such a way that 5 to 15 percent of the surface remains open to allow water to pass. The pavers themselves may not be pervious. Pavers should be laid per manufacturer guidance, but a herringbone pattern is typically the best structural design for rectangular permeable pavers. Permeable pavers are a flexible pavement system, which means a structural analysis must be performed to ensure that the underlying aggregate layer provides sufficient structural support for the anticipated vehicular loads.

Permeable pavers must be built on relatively flat surfaces with slopes not exceeding 5 percent. Designers may consider using a terraced design for permeable pavement in areas with steeper slopes. In all cases, designs must ensure that the slope of the pavement does not lead to ponding on the lower elevations of the pavement surface.

1.4.2. PERVIOUS CONCRETE

Because it is designed without the fine particles used in most concrete aggregate, pervious concrete is a surface that allows water to infiltrate, resulting in a gap-graded mixture with highly connected pore space. Pervious concrete is a rigid pavement system, which means that structural analysis should ensure that the thickness of the slab can support the anticipated surface loads.

Structural and reservoir base layer aggregate that forms the base layer should be uniformly graded to have connected pore spaces, such as ASTM No. 8 or 57 aggregate, and should be washed free of all fine particles. The reservoir layer should generally have a minimum thickness of 6 inches. The subbase layer should generally have a minimum thickness of 4 inches, but should be determined based on structural loading. If the total thickness of the reservoir layer exceeds 4 inches, a subbase layer of washed ASTM No. 2 aggregate is recommended below the 4-inch ASTM No. 57 or 67 aggregate base layer. Exceptions apply to pedestrian applications, where a 6-inch base layer of ASTM No. 57 or 67 aggregates is generally acceptable.

Reservoir and subbase layers should be sufficiently compacted to provide structural support and to prevent differential settling. The leveling and method of compaction will vary depending on the chosen pavement type. To maximize infiltration, care should be taken not to compact the soil subgrade.

Reservoir and subbase layer designs should always conform to local design standards and should address site-specific conditions.

For unlined designs, the bottom slope of a permeable pavement installation should be as flat as possible (i.e., zero percent longitudinal and lateral slopes are preferred, and 5 percent is the maximum) to enable even distribution and infiltration of stormwater.

Permeable/pervious pavement storage volume for infiltration design is calculated using the following equation:

$$S_v = A_p \left[(d_p * n_r) + \left(\frac{t * t_f}{2} \right) \right]$$

where:

- S_v = storage volume [ft³]
- A_p = permeable pavement surface area [ft²]
- d_p = depth of the reservoir layer (or depth of the infiltration sump for enhanced designs with underdrains) [ft]
- n_r = effective porosity for the reservoir layer [0.15 - 0.4]
- i = field-verified infiltration rate for the subgrade soils [ft/day]. If an impermeable liner is used in the design then $i = 0$.
- t_f = time to fill the reservoir layer [day] (assume 2 hours or 0.083 days)

*Note: For enhanced designs that use an infiltration sump, d_p is only the depth of the infiltration sump.

10 LID TECHNICAL STANDARD DETAILS AND SPECIFICATIONS

Permeable pavement storage volume for standard design (no infiltration) is calculated using the following equation:

$$S_v = A_p * d_p * d_p$$

1.5 UNDERDRAINS

Permeable pavement systems without an underdrain are appropriate for soils with a minimum corrected in-situ infiltration rate of 0.3 inches/hour.

Based on the suitability of native soils, the land use of the site, and other considerations (such as whether infiltration is prudent), there are three primary designs for underdrain systems suitable for pervious pavements.

The elevation difference needed for permeable pavement to function properly is generally nominal, although 2 – 4 feet of head pressure from the pavement surface to the underdrain outlet is typically necessary. This pressure may vary based on several design factors, such as required storage depth and underdrain location.

1.6 CONSTRUCTION CONSIDERATIONS

Notes on construction plans should specify that tracked vehicles (versus wheeled vehicles) be used whenever practicable to minimize compaction of subsoils. Construction specifications should also include notes requiring the testing of subgrade infiltration rates before installing aggregate (for infiltrating systems). This step ensures that captured water will draw down in the required duration. If subgrade infiltration rates are drastically lower than design values, the subgrade should be treated by scarifying, ripping, or trenching according to the

recommendations for the bioretention system. The area that will be scarified should be roped off to avoid inadvertent traversing. If infiltration rates remain lower than required, the profile depth must be changed to provide additional storage or the drainage configuration must be altered to regulate the drawdown.

Careful inspection of several construction steps can prevent costly errors. Construction of permeable pavement systems should be performed only by a contractor with experience in permeable pavement installation and who is certified by the Interlocking Concrete Pavement Institute (ICPI) or the National Ready Mix Concrete Association (NRMCA). Lists of certified contractors are at <http://www.icpi.org> or <http://www.nrmca.org>.

1.7 MAINTENANCE

Maintenance of permeable pavement systems is critical to the overall and continued success of the system. This LID feature requires special inspection by experienced personnel. Specific maintenance activities are listed in Table 2, which was developed in the San Antonio LID Manual (Reference 12). Key maintenance procedures consist of the following:

- Adjacent areas that drain to the permeable pavement area should be permanently stabilized and maintained to limit the sediment load to the system.
- Vacuum sweeping should be typically performed a minimum of twice a year. Adjust the frequency according to the intensity of use and deposition rate on the permeable pavement surface.
- Any weeds that grow in the permeable pavement should be immediately sprayed with herbicide or an alternative, environmentally-friendly aqueous solution that can eliminate

them (an alternative solution is preferred; the National Green Infrastructure Certification Program does not support pesticides). Weeds should not be pulled, because doing so can damage the pavement, level, and /or reservoir larger media. The presence of weeds indicates accumulated sediment, which must also be removed. Spray and then pull weeds from pervious concrete to avoid damage.

1.8 COMPATIBILITY WITH OTHER LID PRACTICES

Permeable pavements are typically the upstream LID facilities in a system, but they can be designed adjacent to curb openings. They can also outfall into LID features such as a vegetated/rock swale or a stormwater harvesting basin.

1.9 SPECIFICATIONS

SECTION 303 - AGGREGATES FOR PERMEABLE PAVEMENTS

303.1 DESCRIPTION

This item shall consist of constructing base courses for permeable pavements to the specified depths on a prepared foundation conforming to the lines, grades, and cross sections shown in the contract documents. Base courses may include leveling layer, base layer, subbase layer, open-graded subbase layer, and associated, optional or required liner materials, included in the contract documents. May also include appurtenances such as underdrains.

Table 2: Operation and Maintenance Tasks for Permeable Pavements

Tasks	Frequency	Indicator Maintenance is Needed	Maintenance Notes
Catchment inspection	Weekly or biweekly during routine property maintenance.	Sediment accumulation on adjacent impervious surfaces or in voids/joints of permeable pavement.	Stabilize any exposed soil and remove any accumulated sediment. Adjacent pervious areas might need to be graded to drain away from the pavement.
Miscellaneous upkeep	Weekly or biweekly during routine property maintenance.	Trash, leaves, weeds, or other debris accumulated on permeable pavement surface.	Immediately remove debris to prevent migration into pavement voids. Identify source of debris and remedy problem to avoid future deposition.
Preventative vacuum/regenerative air street sweeping	Twice a year in higher sediment areas.	N/A.	Sweep with a vacuum power or regenerative air street sweeper at least twice per year to maintain infiltration rates.
Replace fill materials	As needed.	For paver systems, whenever void space between joints becomes apparent or after vacuum sweeping.	Replace bedding fill material to keep fill level with the paver surface.
Restorative vacuum/regenerative air street sweeping	As needed.	Surface infiltration test indicates poor performance or water is ponding on pavement surface during rainfall, or if weeds grow.	Sweep with a vacuum power or regenerative air street sweeper to restore infiltration rates.

303.2 MATERIALS

Coarse aggregate shall be of the types designated in the contract documents, and shall consist of clean, tough, durable fragments of crushed stone, or crushed gravel, conforming to the gradations in Table 3 and shall also meet the following:

- A. Be double-washed, sufficient to remove dust and other coatings.
- B. Be free from clay balls, organic matter, and other deleterious substances.
- C. Minimum 75 percent by mass (weight) of the material coarser than the No. 4 sieve with at least 2 fractured faces, and 90 percent shall have one or more fractured faces as determined by ASTM D5821.

- D. Have not more than 5 percent of flat or elongated pieces (>5:1) as specified in ASTM D4791.
- E. Material shall have a CBR of at least thirty (30) as determined by laboratory test on a 4-day soaked sample in accordance with ASTM D1883.
- F. The sub-base and base aggregate should be hard, durable, crushed stone with a Los Angeles (LA) Abrasion of < 40 (per A-STM C131 and C535).

Minimum sub-base thickness depends on vehicle loads, soil type, and stormwater storage requirements. Typical sub-base depths range from 6 to 24 inches. The ICPI recommends base/sub-base thicknesses for pavements up to a

lifetime of 1 million 18,000-lb equivalent single axle loads (ESALs). For example, at lifetime ESALs of 500,000 with a CBR of 5 percent, the sub-base (ASTM No. 2 stone) should be 18 inches and the base (ASTM No. 57 stone) thickness should be 4 inches. Increased aggregate sub-base thicknesses can be applied for increased stormwater volume storage. See ICPI guidelines for details on base thickness and design.

The levelling layer is an open-graded stone, typically ASTM No. 8 stone, between the wearing surface and the reservoir layer, for providing separation and preventing migration between the layers due to differences in material and void sizes underneath.

10 LID TECHNICAL STANDARD DETAILS AND SPECIFICATIONS

Saturated hydraulic conductivity of the gravel shall be not less than 10 inches per hour according to ASTM D5856-95 (2000) when compacted to a minimum of 95 percent Standard Proctor, ASTM 698.

The reservoir layer is an open graded stone (recommended ASTM No. 2, No. 3, or No. 57 stone or approved equal) under the choker layer, for meeting the retention volume requirement (to the maximum extent practicable, where applicable). The depth of the stone shall be determined based on the required storage volume for the site and pavement design requirement.

Gradation for base courses shall be as presented in Table 3.

Impermeable waterproof membranes should be used in permeable pavement systems as follows:

- G. Facilities within 10 feet of a structure shall be lined on the side adjacent to the structure.
- H. At the interface between pervious pavement and traditional pavement.
 - I. In areas where infiltration is not permitted, such as areas prone to contaminated runoff and for utility protection.
 - J. Facilities designed for water re-use or harvesting.
 - K. Where the installation is located on expansive soils, as recommended by the Geotechnical Engineer.

Upon completion of subgrade work, the Engineer shall be notified and shall inspect the subgrade before the contractor continues installation. The Engineer shall have the option to perform infiltration testing on the subgrade to verify minimum infiltration rates, at the contractor's expense where specified on the contract documents.

Any accumulation of debris or sediment which takes place after approval of subgrade shall be removed prior to installation continuing at no extra cost.

The contractor shall be allowed to perform subgrade compaction and can utilize geotextile fabric or impermeable liners as specified in the contract documents for permeable pavements where no infiltration rate is specified for the subgrade.

Where erosion of subgrade has caused accumulation of fine materials and/or surface ponding, this material shall be removed with light equipment and underlying soils scarified to a minimum additional depth of 6 inches with a rake and a tracked vehicle used in combination, or equivalent. Construction equipment shall not be allowed on the subgrade, except as noted above.

Trucks meeting the same cleanliness requirements of the double-washed materials shall be used during hauling. Trucks shall be inspected and cleaned prior to each use. Do not install aggregate base course when rainfall or other weather conditions will detrimentally affect the quality of the work.

Final grading should be completed by machinery operating on a preliminary subgrade that is at least 12 inches higher than the grade to distribute equipment load. The final excavation is achieved as the machinery is pulling back and traveling on preliminary grade as final grade is excavated.

Table 3: Base Course Gradation

Pavement Reservoir Layer	Choker Layer for Permeable Pavements	Filter Layer	Storage/Drainage Layer
ASTM No. 2 or No. 3 Stone	AASHTO No. 57 Stone	AASHTO No. 8 Stone	AASHTO No. 57 Stone

At locations where the native soil design infiltration rate is insufficient to drain the underground runoff within 36 hours, an underdrain connected to a downstream drainage facility should be installed. The underdrain should be installed in accordance with Specification 622.

Geosynthetics meeting the requirements of MAG Specification 796 shall be placed on the sides of open-graded stone, to prevent migration of adjacent fine material into the permeable pavement stone.

303.3 GENERAL

Careful attention to the subgrade preparation during construction is required to balance the structural support requirements of the material and the infiltration rates. Relative uniformity of the subgrade conditions is necessary to prevent differential settling or other stresses to the system for all permeable pavements. The subgrade shall not be compacted for installations where contract documents specify a minimum infiltration rate for the subgrade.

Do not dump the aggregate base course in piles, but evenly spread it and place the aggregate on the prepared subgrade in layers of uniform thickness without segregation. Where the base course is constructed in more than one layer, clean previously constructed layers of loose and foreign matter prior to placing subsequent layers.

Avoid subgrade preparation during rainfall or immediately after a rainfall event when the subgrade is wet. If machinery must access the final grade, limit the access to a specific travel way that can be tilled before application of the base aggregate or place heavy steel plates on subgrade and limit traffic to the protective cover.

Moisten and roll each lift of aggregate with a 10-ton roller, keeping equipment movement over exposed subgrade to a minimum. Roll each lift between 4 and 6 passes. If a required depth of aggregate in a lift exceeds 10 inches, the aggregate layer shall be rolled in 10-inch lifts.

Make adjustments in placing procedures or equipment to obtain true grades, to minimize segregation and degradation, to reduce or increase water content, and to insure a satisfactory aggregate base course.

Geosynthetics along edges – Geotextile fabric or impermeable liners, or both, shall be used along the edges or sides of aggregate base course materials for permeable pavement as specified in the contract documents. Following placement of an aggregate base course, and at the conclusion of each day's work, the geotextile or impermeable liner, or both, shall be folded back and secured to protect from sediment washout along all bed edges. At least a 2-foot strip shall be used to protect stone from adjacent bare

soil. This edge strip shall remain in place until all bare soils contiguous to beds are stabilized and fully vegetated or until the wearing surface for the permeable pavement has been placed.

Unfinished Edges of Base Course – In fill conditions, place earth or other approved materials along any unfinished edges of the base course in such quantity that it will compact to the thickness of the aggregate base course being constructed. In each operation, allow at least a 2-foot width of the shoulder along all unfinished edges to be compacted with vibratory plates and compacted simultaneously with the rolling and compacting of each layer of aggregate.

Protection work will be performed by the contractor at their expense. As construction is completed, maintain and protect the aggregate base course, except where a portion of the succeeding course is under construction thereon. Maintenance includes drainage, rolling, shaping, and watering, as necessary, to maintain the course in proper condition. Correct deficiencies in thickness, composition, and construction that develop during the maintenance, to conform to the requirements specified herein. Maintain sufficient moisture by light sprinkling with water at the surface to prevent dusty conditions.

Runoff onto an aggregate base course shall be minimized until the site is fully stabilized. Diversion ditches or other approved types of erosion and sediment control measures shall be placed at the toe of slopes that are adjacent to permeable pavement areas, to prevent sediment from washing into areas of aggregate base course at all times during and after construction. Any sediment

accumulation into the aggregate base course shall be removed immediately by cleaning or replacement of the aggregate by the contractor at no cost to the owner.

303.4 TESTING

All materials shall be inspected, tested and accepted by the Engineer before incorporation in the work. Any work in which untested or unaccepted materials are used will be performed at the contractor's risk and may be considered as unacceptable and unauthorized work.

The contractor shall furnish material samples for inspection or testing. These samples may be required prior to or during the use of the material or at any time prior to acceptance of the work. Unless otherwise designated, materials shall be sampled and tested in accordance with the requirements of the standards that are current on the date of advertisement for bids.

Prior to production and delivery of aggregates, take at least 1 initial sample in accordance with ASTM D75. Collect each sample by taking 3 incremental samples at random locations from source material to make a composite sample. Samples of untreated aggregates or soils shall be taken from the road at the lay down machine prior to compaction.

Repeat sampling procedure when source of material is changed or when deficiencies or variations from specified grading of materials are found in testing.

Testing should be located and done at an adequate frequency to produce a soil profile characterization that fully represents the infiltration capacity of permeable pavement area.

10 LID TECHNICAL STANDARD DETAILS AND SPECIFICATIONS

Pilot infiltration tests are appropriate methods for estimating field infiltration rates. Infiltration tests should be conducted at the subgrade surface and followed by excavation into the soil profile below the subgrade surface where stormwater will infiltrate. Infiltration tests conducted at the subgrade surface provide valuable information for permeable pavement design.

Infiltration tests should be done once the subgrade preparation is complete to verify design infiltration rates were not significantly affected by compaction. Testing pits are not acceptable at this stage in order to maintain the structural integrity of the subgrade. Double ring infiltration tests are recommended for accuracy (ASTM C1701).

303.5 ACCEPTANCE

Testing responsibilities will be performed by the contractors at their expense. Materials approval testing may be performed by the Engineer. Failure to detect defective work or materials early will not prevent rejection if a defect is discovered nor shall it obligate the owner for final acceptance at any time. Submit all test reports to the Engineer.

- A. **Gradation** – Test each sample of aggregate base course material for gradation in accordance with ASTM C 136 and with the sampling described in Section 303.4.
- B. **Thickness** – Measure each 100 square yards of each layer of aggregate base course placement. Make depth measurements by test holes, at least 3 inches in diameter, through the base course. Where base course deficiency is more than 0.5 inch, correct by scarifying, adding mixture of proper gradation, re-blading, and re-compacting. Where the measured thickness is more than 0.5-inch thicker than indicated, consider it as the indicated thickness plus

0.5 inch for determining the average. The average thickness is the average of the depth measurements for the entire area and shall not under-run the thickness indicated in the contract documents without written approval from the Engineer.

303.6 PAYMENT

The unit of measure for aggregates for permeable pavements will be:

- Cubic yard for the levelling layer, reservoir layer, subbase layer, and the filter layer.
- Geotextile will be measured by the square foot.

The actual number of cubic yards measured complete in place will be paid for the contract unit price per cubic yard, for which payment will include all labor, materials, tools, equipment and incidentals necessary to complete the work as specified herein. Payment will also include all subgrade preparation and testing necessary to achieve the required placement.

MAG SECTION 323 – PLACEMENT OF PERVIOUS CONCRETE

323.1 DESCRIPTION

Pervious concrete describes a near-zero-slump, open-graded material with sufficient continuous voids to allow water to pass from the surface to underlying layers. It does not look or behave like typical concrete. The finished surface is not tight and uniform but is open and varied to allow permeability. Minor surface irregularities, minimal amounts of surface raveling, and color variations are normal. Pervious concrete is usually part of a water management system used to reduce runoff rates and volumes from on-grade surfaces such as patios,

walkways, driveways, fire lanes, and parking spaces. The work covered by this specification is intended for light traffic areas and consists of furnishing all materials, labor, and equipment for the placement of pervious concrete.

323.2 MATERIALS

Materials utilized in pervious concrete shall conform to the requirements of the MAG Specification Section 723.

323.3 GENERAL

The pervious concrete contractor shall be experienced in the installation of pervious concrete and shall employ no less than 1 NRMCA-certified pervious concrete craftsman who must be on site overseeing each placement crew during all pervious concrete placements or employ no less than 3 NRMCA-certified pervious concrete installers on each pervious concrete placement crew during all pervious concrete placements. The minimum number of certified individuals (1 craftsman or 3 installers) is to be present at each pervious concrete placement, and a certified individual is to oversee the placement crew and the construction procedures.

Field test(s) of pervious concrete shall be performed by an individual certified as both an NRMCA-certified pervious concrete technician or equivalent, and American Concrete Institute concrete field technician grade 1 or equivalent as approved by the Engineer.

323.4 CONSTRUCTION OF TEST SECTION(S)

If required by the Engineer or contract documents, the contractor shall construct a test section(s) using the same equipment and placement crew as proposed to be used for the remainder of the pervious concrete work. Test sections may be placed non-contiguously. Test section(s) shall be a minimum of 275 square feet and shall include a construction joint and a control joint. Test section(s) must be at the required project thickness to demonstrate that in-place void contents, unit weights, and infiltration rates can be met and to demonstrate effective jointing that does not compromise the cured concrete integrity. Test section(s) may be placed at any of the final pervious concrete placement locations and may be incorporated into the work if approved by the Engineer.

323.4.1 Test Panel Infiltration:

Test panels shall be tested for infiltration in accordance with ASTM C1701.

323.4.2 Test Panel Acceptance:

Satisfactory test panels will be determined by:

- A. Infiltration rate of at least 100 inches per hour.
- B. Compacted thickness within 0.25 inches of the specified thickness.
- C. Void content \pm 3 percent of the design void content.
- D. Unit weight \pm 5 pounds per cubic foot of the design unit weight.

If test panels meet the requirements of 323.4.2, they can be left in place and included in the completed work. If test panels do not meet those requirements, they shall be removed and disposed of in an approved manner and replaced with an acceptable test panel at the contractor's expense.

323.4.3 Sample fresh pervious concrete in accordance with ASTM C172. The size of the sample shall be at least 1 ft³. The temperature of the pervious concrete shall be tested in accordance with ASTM C1064 and shall be 95 degrees or less unless a higher temperature is approved by the Engineer. Complete at least one density test on a sample of freshly mixed pervious concrete in accordance with ASTM C1688. The acceptable fresh density shall be within \pm 5 lbs/ft³ of the approved mix design density.

323.4.4 Remove cores not less than 7 days after placement in accordance with ASTM C42 Obtaining and Testing Drilled Cores and Sawed Beams of Concrete. Test thickness in accordance with ASTM C174 and test saturated density in accordance with ASTM C140, paragraphs 8.3 and 9.3.

Tolerance for thickness, and density, reported as the average of three cores of each test panel, shall be as follows:

- A. The average compacted thickness shall not be greater than 0.25 inch less than the specified thickness, with no single core exceeding 1 inch less than the specified thickness; nor shall the average compacted thickness be 1.5 inches more than the specified thickness.
- B. The acceptable hardened density shall be within \pm 5 lbs/ft³ of the approved mix design density.

323.5 PERVIOUS CONCRETE BASE PREPARATION

- A. **Subgrade Preparation** – Shall be in accordance with proposed Specification 303.
- B. **Base Materials** – Shall be in accordance with proposed Specification 303.

323.6 PLACEMENT

323.6.1 Spreading and Finishing:

- A. Moisten the base materials or subgrade immediately prior to concrete placement. Deposit concrete directly from the transporting equipment onto the base materials or subgrade, as appropriate.
- B. Pervious concrete shall be constructed a minimum of 6 inches in depth, unless otherwise specified in the plans or special provisions. When hot weather is anticipated, recommended practices in ACI 305, Specification for Hot Weather Concreting, can provide good Reference information to help the contractor prepare and submit detailed procedures for the production, transportation, placement, protection, and curing of pervious concrete for approval by the Engineer. Evaporation retarders shall be available during placement and applied as needed in accordance with the manufacturer's recommendations to protect the pervious concrete from rapid evaporation (see MAG 323.7).
- C. Each truckload shall be visually inspected for moisture consistency prior to concrete discharge. Water addition shall not be permitted at the point of discharge to obtain the required mixture consistency and truckloads lacking the required moisture consistency shall be rejected as determined by the inspector.
- D. Discharge shall be a continuous operation and shall be completed as quickly as possible.

10 LID TECHNICAL STANDARD DETAILS AND SPECIFICATIONS

Concrete shall be deposited as close to its final position as practical and such that discharged concrete is incorporated into previously placed and plastic concrete. If consolidation occurs during concrete discharge, placement shall be halted, the mixture shall be addressed, and the consolidated portion removed and replaced immediately.

- E. Pervious concrete shall be uniformly deposited over the entire formed area. The concrete will be spread using a come-along, short-handle square ended shovel or rake, or similar equipment.

323.6.2 Compaction of Pervious Concrete

Rolling compaction shall be achieved using a motorized or hydraulically actuated, rotating, weighted tube screed that spans the width of the section placed and exerts a minimum vertical pressure of 10 pounds per square inch (psi) on the concrete. A steel pipe roller meeting the same criteria may be used as an alternative.

Plate compaction may be necessary in small areas. A standard soil plate compactor with a base area of at least two square feet that exerts a minimum pressure of 10 psi on the concrete through a 0.75-inch minimum plywood cover shall be used in these cases. Cross-rolling shall be performed using a roller specifically designed to smooth and compact pervious concrete. Lawn rollers are not allowed. Foot-traffic shall not be allowed on fresh concrete.

Placement operations shall not result in the voids becoming sealed in order to maintain an adequate continuous voids structure for water passage through the pervious concrete. Surface depressions shall be corrected immediately after compaction by placing fresh pervious concrete

in the depressions and compacting using a hand tamper or roller compactor. The final surface shall not deviate more than 0.375-inch from a 10-foot straightedge laid on the surface.

323.6.3 Joints

Contraction joints shall be installed at locations and spacing shown in the contract documents at one-quarter the depth of the thickness or a maximum of 1.5 inches for roadway and alley pavements, and at 0.5 inch for sidewalks and trails.

Unless otherwise approved, contraction joints shall be constructed by one of the following methods:

- A. **Rolled Joints** – Shall be formed in plastic concrete using a steel pipe roller to which a beveled fin with the required diameter to achieve the joint depth has been attached around the circumference of the roller. Rolled joints are formed immediately after roller consolidation. Sidewalks and trails shall have rolled joints.
- B. **Sawed Joints** – Shall be constructed as soon as the pervious pavement can be sawed without raveling the sawed edge and before initial cracking occurs, using a wet saw or an early-entry saw. Sawed joints shall typically be constructed between 24 – 48 hours after concrete placement, depending on site conditions. Only the area occupied by the concrete saw shall be uncovered and exposed with all other curing materials remaining in place. Any dust or slurry generated during sawing shall be immediately removed during the sawing operation. Immediately after sawing each joint, the exposed area shall be fogged with water and re-covered in accordance with MAG Section 323.7.

Construction joints shall be installed at locations and spacing shown in the contract documents and whenever concrete placement is suspended for a sufficient length of time that concrete may begin to harden.

Expansion joints shall be installed when pervious concrete will abut existing concrete slabs or other structures such as walls, footings, columns, catch basins, stairs, light poles, and other points of restraint.

Use isolation joints only where pavement abuts fixed objects, such as buildings, foundations, and manholes. Extend isolation joints through the full depth of the pavement. Fill the entire isolation joint with expansion joint material that complies with MAG Specification 729.

323.6.4 Curing

The contractor shall submit a curing plan to the Engineer for review and approval. The curing must begin within minutes unless longer working time is approved by the Engineer. The surface and edges shall be securely covered with polyethylene sheeting/film having a minimum thickness of 30 mil. The cover shall be checked daily to verify that it has not been displaced or damaged, and that condensation is evident underneath the sheeting. Damaged sheeting shall be repaired immediately. Displaced sheeting shall be replaced immediately. When there is no observable condensation, 1.5 gallons of water per square yard shall be applied to the surface of the pervious concrete. Curing methods shall remain in place for a minimum of 7 days or as directed by the Engineer. Pavement sections shall not be opened to light vehicular traffic until the concrete has cured for at least 14 days (28 days for heavy traffic), and until approved by the Engineer for opening to traffic.

A fog shall be sprayed above the surface, before covering, when required due to hot weather conditions. Equipment must include fog nozzles that atomize water using air pressure to create a fog blanket over the slab.

323.8 QUALITY CONTROL FIELD TESTING

Complete at least one density test on a sample of freshly mixed pervious concrete for every 50 cubic yards or each day of concrete placement, whichever is less, in accordance with ASTM C1688. Sample fresh pervious concrete in accordance with ASTM C172. The size of the core shall be 6 inches in diameter. The temperature of the pervious concrete shall be tested in accordance with ASTM C1064 and shall be 95 degrees or less unless a higher temperature is approved by the Engineer. Discharge of the previous concrete shall be completed in accordance with MAG Specification 725.9 (A)(4).

Remove three cores from each lot of 5,000 square feet or each day's production, whichever is less, in accordance with ASTM C42 not less than 7 days after placement of the pervious concrete. Select three locations in accordance with ASTM D3665. Upon approval of the Engineer, small test sections may be cast for sample extraction along with each placement to avoid removing cores from in-place work. Measure the cores for thickness in accordance with ASTM C174.

The cores shall be measured for void content and unit weight determined using the methods described in Section 323.4.2 of this specification. Satisfactory test panels will be determined by:

- A. Compacted thickness ± 0.25 inches of the specified thickness.
- B. Void content ± 3 percent of the design void content.

- C. Unit weight ± 5 pounds per cubic foot of the design unit weight.

If pervious concrete fails to meet the above requirements, the Engineer shall make a determination of acceptance, or rejection. The infiltration of the pavement surface shall be tested in accordance with ASTM C1701. All applied water shall infiltrate directly without puddle formation or surface runoff, and the testing shall be observed by the Engineer. A minimum infiltration rate of 100 inches per hour shall be achieved. The test results should be submitted to the Engineer and the core holes should be filled with standard concrete.

323.9 TOLERANCES

Mechanically sweep or vacuum pavement with clean equipment or flush with water before testing for compliance with tolerances.

Tolerance for hardened thickness, and density, reported as the average of three cores of each test panel shall be as follows:

- A. Average hardened thickness from a lot shall not be more than 0.5 inch less than the specified thickness, with no single core exceeding 1 inch less than the specified thickness; nor shall the average hardened thickness be 1.5 inches more than the specified thickness.
- B. Average hardened density from a lot shall be within ± 5 lbs/ft³ of the average hardened density of the test section(s) from Section 323.4.
- C. Unless otherwise specified in the Specifications, pervious concrete shall have a minimum infiltration rate of 100 inches per hour when tested in accordance with ASTM C1701.

323.10 Acceptance

Pervious concrete does not look or behave like typical concrete. The finished surface shall be open and varied to permit permeability. Minor surface irregularities and moderate amounts of surface raveling and color variations are normal and acceptable. Pervious concrete shall have no visible excess cement paste, tears, or gouges. Roller constructed joints shall have smooth, rounded, and uniformly compacted edges. Saw-cut joints shall not contain cement paste or dust nor exhibit evidence of spalling.

Acceptance will be based on conformance to the specifications. When a lot is outside one of more of the tolerances in MAG Section 323.9, the lot shall be subject to rejection, removal, and replacement at the contractor's expense, unless accepted by the Engineer.

323.11 PAYMENT

Payment for pervious concrete shall be made at the contract unit price per square foot for each thickness shown on the plans.

SECTION 344 - PLACEMENT OF PERMEABLE INTERLOCKING CONCRETE PAVERS

344.1 DESCRIPTION

This work shall consist of constructing permeable unit pavers on a prepared subgrade in accordance with these specifications and in conformity with the lines, grades, thicknesses, and typical sections shown in the contract documents or as directed by the Engineer.

10 LID TECHNICAL STANDARD DETAILS AND SPECIFICATIONS

The permeable unit pavers shall consist of a combination of unit pavers and aggregate for the joints and bedding layer, to form an integrated, structural wearing surface when compacted.

Permeable interlocking concrete pavers are designed with various shapes and thicknesses from high-density concrete to allow infiltration through a built-in pattern of openings or joints filled with aggregate. Pavers are typically 3.125 inches thick for vehicular applications and pedestrian areas may use 2.375-inch thick units.

Properly installed and maintained, high-density pavers have high load bearing strength and are capable of carrying heavy vehicle weight at design speeds below 30 miles per hour.

344.2 MATERIALS

344.2.1 Permeable paver materials shall be approved in accordance with MAG Specification 106 requirements, and as described below:

- A. All unit pavers shall meet surface requirements of the latest ADA requirements and accessibility guidelines.
- B. Unit pavers shall be of the type, style, color, and other details as described in the contract documents and in accordance with all manufacturer's recommendations for the selected unit paver system.
 1. **Shapes:** rectangular, L-shaped, hexagonal, square as specified in design plans.
 2. **Thickness:** 3.125 inches for vehicular use, 2.375 inches for pedestrian use.
 3. **Colors:** are specified in the design plans.

4. **Concrete Unit Pavers:** The material and fabrication for the unit pavers shall meet or exceed the requirements of ASTM C936 Solid Concrete Interlocking Paving S-34 Units and must allow a minimum infiltration rate of 10 inches/hour through the pavement upon installation.
 - a.) Portland cement: ASTM C150, Type 1.
 - b.) Aggregate: Normal weight ASTM C33.
 - c.) Pigments: ASTM C979 and as specified in the Contract Documents.
 - d.) Other constituents: Previously established by test or experience as suitable for use in concrete, in compliance with applicable ASTM standards or as otherwise approved by the Engineer.
 - e.) Paver physical properties:
 - 1.) Provide only sound units free of defects that would allow proper placing of units to achieve the specified pavement strength and performance.
 - 2.) Compressive strength: ASTM C140, when delivered to the project site, average compressive strength of not less than 8,000 psi, with no individual unit less than 7,200 psi.
 - 3.) Absorption: ASTM C140, average absorption not greater than 5 percent, with no individual unit greater than 7 percent.
 - 4.) Abrasion resistance: ASTM C418, maximum volume loss of 0.915 cubic inches / 7.75 square inch average thickness loss of no more than 0.118 inch (3 mm) due to abrasion testing.

- 5.) Dimension tolerances: Length +/- 0.0625inch, height +/- 0.125 inch.

5. **Other Material:** Clay, brick, or other alternate materials shall be utilized as called for in the contract documents and shall meet physical properties described above in B.4., unless otherwise specified in contract documents.
6. **Bedding or Joints:** AASHTO No. 8 aggregate or similar, as directed by the contract documents and in accordance with Specification 303.

344.2.2 Base Course Materials:

Subgrade

- Open graded subbase: No. 2 stone.
- Open graded base: No. 57 stone.
- Levelling course: No. 8 stone.
- Soils should be analyzed by a qualified professional for infiltration rates and load bearing, given anticipated soil moisture conditions.
- The ICPI recommends a minimum CBR of 4 percent (96-hour soak per ASTM D 1883 or AASHTO T193) to qualify for use under vehicular traffic applications.
- Refer to proposed Specification 303, common components and design criteria for permeable pavement systems guidelines and construction techniques to reduce compaction are included in proposed Specification 303.

344.3 GENERAL

Contractor shall submit drawings and documentation as required in this specification and obtain written acceptance of submittals before using the materials or methods requiring approval.

- A. **Contractor Qualifications** – As part of the bid submission, the contractor will:
1. Submit written evidence of an installer who will be on-site at all times during the unit permeable interlocking paver installation, with a current certificate from the ICPI Installer Certification Program and a record of completion from the Permeable Interlocking Concrete Paver (PICP) Specialist course, or
 2. Submit written evidence that the contractor will obtain the service of a consultant who has the required certifications and who will be on site at all times during the permeable unit paver installation, acting as the installer for the project.
- B. **Testing Agency** – Within 7 days after notice to proceed, the contractor shall submit the name and location of a third-party quality assurance (QA) testing agency with experience in testing permeable unit pavements, who will oversee and document production and assembly. Use of testing services will not relieve contractor of the responsibility to furnish materials and construction in full compliance with the contract documents.

344.4 TEST SECTIONS

Testing Panels – At least 15 days before construction of the permeable unit paver installation, and following the Engineer’s acceptance of the qualifications described above, the contractor shall provide a minimum of 1 test panel for acceptance. Place, joint and cure the test panel, to be a minimum of 275 square feet in size or as specified in the contract documents, at the required

project thickness to demonstrate to the Engineer’s satisfaction that the unit pavers and design flow rates are acceptable, and that a satisfactory pavement can be installed at the site location.

344.5 PERMEABLE INTERLOCKING PAVEMENT BASE PREPARATION

- A. **Subgrade Preparation** – Shall be in accordance with proposed Specification 303.
- B. **Base Materials** – Shall be in accordance with proposed Specification 303.

PLACEMENT

Pre-Placement Meeting – A mandatory pre-installation meeting will take place at least 1 week prior to installation of the permeable unit pavers and shall include at a minimum, the Engineer, inspector, general contractor, permeable unit paver installer, and field testing agency.

Install base materials in accordance with proposed Specification 303. Moisten, spread and screed aggregate bedding material and fill any voids left by screed rails. Do not roll or compact the bedding material prior to placing the permeable unit pavers.

Lay the permeable unit pavers in the type, style, pattern, dimensions, and locations with joint widths as recommended by the manufacturer and shown on the contract documents. Maintain consistent and uniform patterns for the entire pavement area.

Fill gaps at the edges of the paved area with cut units. Cut the permeable unit pavers subject to vehicular traffic shall be no smaller than 0.67 of a whole unit and shall have no sharp edges. Patterns shall be maintained to the extent possible in placing cut units to fill gaps in the pattern. Stagger blocks to avoid running bond or other straight joints or seams in the pattern.

Fill the openings and joints with washed ASTM No. 8 aggregate. Some permeable unit paver joint widths may be too narrow to accept most No. 8 stone. In such case, use joint material that will fill joints such as washed ASTM No. 8 or No. 9 stone. Sweep excess aggregate from the surface.

Compact and seat the permeable unit pavers into the bedding material using a low amplitude, 75 – 90 Hz plate compactor capable of at least 5,000 lbf centrifugal compaction force. This will require at least 2 passes with the plate compactor over the entire surface.

Apply additional ASTM No. 8, No. 9 or No. 89 aggregate to the openings and joints as needed filling them in completely, then remove excess aggregate by sweeping, and make at least 2 more passes with the plate compactor over the entire surface.

All permeable unit pavers within 6 feet of the laying face must be fully compacted at the completion of each day’s work.

344.6 QUALITY CONTROL FIELD TESTING

Testing responsibilities will be performed by the contractor’s testing agency or the manufacturer at the contractor’s expense, as described below. Materials approval testing will be performed by the Engineer. Failure to detect defective work or materials early will not prevent rejection if a defect is discovered nor shall it obligate the owner for final acceptance at any time.

- A. **Roughness Test** – Test finished permeable unit paver system with a 10-foot straightedge, applied parallel with and at right angles to the center line of the paved area. Correct deviations in the surface in excess of 0.5 inch by removing the unit pavers as necessary and then loosening, adding or removing material,

10 LID TECHNICAL STANDARD DETAILS AND SPECIFICATIONS

re-shaping, watering, and recompacting. The smoothness requirements specified herein apply only to the top lift of each layer, when base course is constructed in more than one lift.

- B. **Infiltration Test** – The full permeability of the pavement surface shall be tested prior to final acceptance by application of clean water at least 5 gallons per minute, using a hose or other distribution device. Water used for the test shall be clean, free of suspended solids and deleterious liquids. All applied water shall infiltrate directly without large puddle formation or surface runoff, and the testing shall be observed by the Engineer. A minimum flow rate of 100 inches per hour is required.

PROTECTION

- A. As construction is completed, maintain and protect the permeable unit pavers. Correct deficiencies in thickness, composition, construction, and smoothness, which develop during the maintenance, to conform to the requirements specified herein.
- B. Finishing along the edges of the permeable unit pavers for protection during construction shall be until the site is fully stabilized, at which time excess filter fabric and impermeable liners can be cut back to the pavement edges.
- C. In addition, runoff onto the permeable unit pavers shall be minimized until the site is fully stabilized as described in the contract documents. Diversion ditches or other approved types of erosion and sediment control measures shall be placed at the toe of slopes that are adjacent to permeable unit pavers, to prevent sediment from washing into pavement areas at all times during and after construction. Any sediment accumulation onto the permeable pavement

shall be removed immediately by cleaning or replacement of the aggregate by the contractor at no cost to the owner.

344.8 MEASURE AND PAYMENT

The unit of measure for permeable unit pavers will be in square yards for the type(s) specified in the contract documents. The actual number of square yards complete in place will be paid for at the contract unit price per square yard, which payment includes unit pavers, bedding material, and joint filler, complete and in place. Payment will include costs for furnishing all materials, labor, tools, equipment, and incidentals to complete the work.

SECTION 622 – UNDERDRAIN FOR LID FACILITIES

622.1 DESCRIPTION

This work shall consist of furnishing and placing the items specified to construct perforated PVC pipe for underdrains, cleanouts, observation wells, field connections to existing stormdrains as shown in the drawings and in accordance with MAG Standards, where applicable. Except as herein stated, the requirements specified in MAG Specification 505 are applicable to this specification.

622.2 MATERIALS

All materials shall meet the following requirements:

- A. **PVC (perforated or non-perforated as specified in the contract drawings)** – Shall be schedule 40 for underdrains and pipe risers and shall conform to Section 745 of the MAG Specifications. PVC shall meet ASTM D 2729 and ASTM D 3034 specifications.
- B. **Screw Cap** – Shall be threaded PVC with 2 inch square lug.

- C. **Fittings** – Fittings shall be PVC and used as indicated on the design drawings.
- D. **Cleanout** – The cleanout cover assembly in pavement shall be cast iron and have an adjustable housing with a cast iron cover as indicated in the design drawings.
- E. **Observation Well** – 2 inch well test plug using EnviroTech, ErgoGrip, or approved equal with tethering eyelet.
- F. **Field Connections** – All materials shall meet the requirements set forth in the MAG Specifications 324, 505, 601, or modified in the special provisions.

622.3 GENERAL

622.3.1 General installation

The contractor shall make the requisite excavations for constructing the underdrain, appertaining structures, and connections and make provisions to maintain and protect fences, trees, underground installations, and other structures. Contractor shall be responsible for the repair of all damage that may result from his operations.

The contractor shall, after giving due notice to parties affected thereby, provide plank crossings, barricades or other means of maintaining and protecting travel on streets or roads in which trenches are excavated and shall maintain these in good and safe condition until construction is completed and shall then remove such temporary expedients and restore such ways to their proper condition.

Perforated pipes shall be placed with perforations down. Pipe shall be placed with the bell end up grade. Pipe sections shall be joined with appropriate couplings. The ends of underdrain pipe shall be plugged on the upstream side as directed by the Engineer.

622.4 TESTING

When construction is complete, the contractor shall test all completed underdrain systems for continuous, unimpeded flow.

Suggested test methods for each pipe run are as follows:

- At the highpoint or upstream end of underdrain pipe, open cleanout and insert hose from water source.

- Turn on water.
- Acceptance of pipe run consists of free flow of water through drain outlet into the existing storm sewer structure.
- Any sections of the underdrain that are clogged or crushed shall be repaired at the contractor's expense.

622.5 MEASURE AND PAYMENT

622.5.1 Underdrain Pipe

Payment for underdrain pipe will include all costs for furnishing all materials, labor, tools, equipment and incidentals (including pipe risers, caps, and fittings) to complete the work. The unit of measurement will be linear feet.

622.5.2 Field Connection

The unit of measure for underdrain cleanout and observation well will be per each. Payment for underdrain cleanout or underdrain observation well will be made at the contract unit price per each, which will include excavation, shoring, backfill, compaction, installation of cleanout including wye and jointing, pipe riser, gaskets, frame and cover or screw cap, concrete encasement, and all labor, materials, tools, equipment and incidentals needed to complete work specified.

10 LID TECHNICAL STANDARD DETAILS AND SPECIFICATIONS

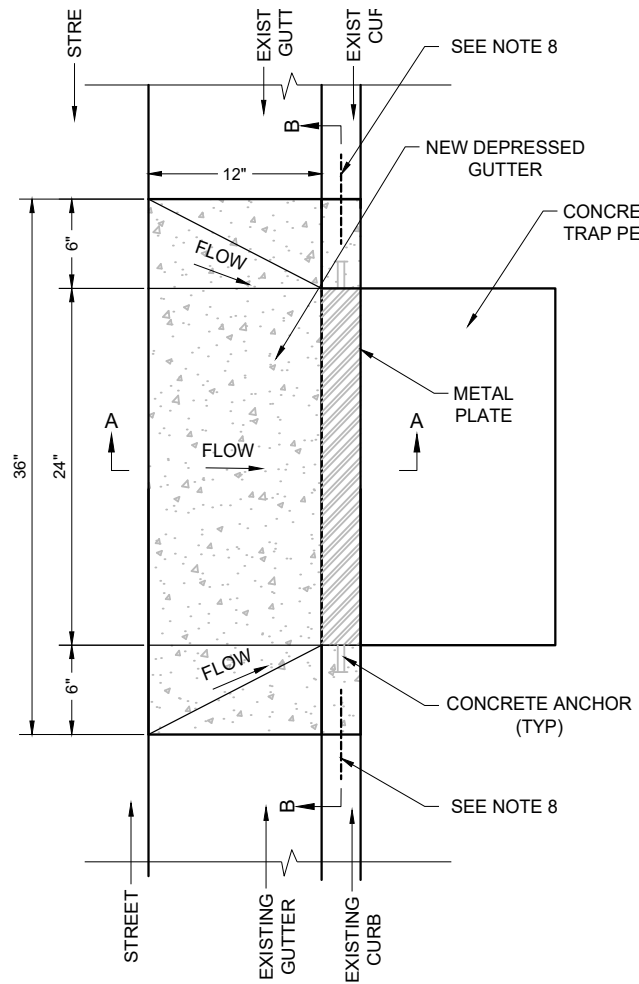

CURB OPENING - TYPE 1
RETROFIT OPENING WITH VERTICAL CUT

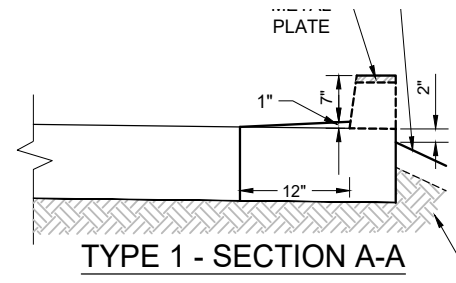

TYPE 1 - SECTION A-A

1. REQUIREMENTS OF ASTM A-108.
2. METAL PLATE 6X2X1/8 CHANNEL SHALL MEET THE REQUIREMENTS OF ASTM A-500 GRADE B.
3. END PLATES SHALL MEET THE REQUIREMENTS OF ASTM A-36.
4. ENTIRE ASSEMBLY SHALL BE HOT DIP GALVANIZED IN ACCORDANCE WITH ASTM A-123.
5. DESIGN VERTICAL WHEEL LOAD IS 8.5 KIPS.
6. SEE SPECIFICATION 341 FOR MATERIAL AND CONSTRUCTION INFORMATION.
7. REFER TO AASHTO ROADWAY DESIGN GUIDE FOR CLEAR ZONE REQUIREMENTS FOR SPEED DESIGNS.
8. DRILL & EPOXY #4x6" REBAR

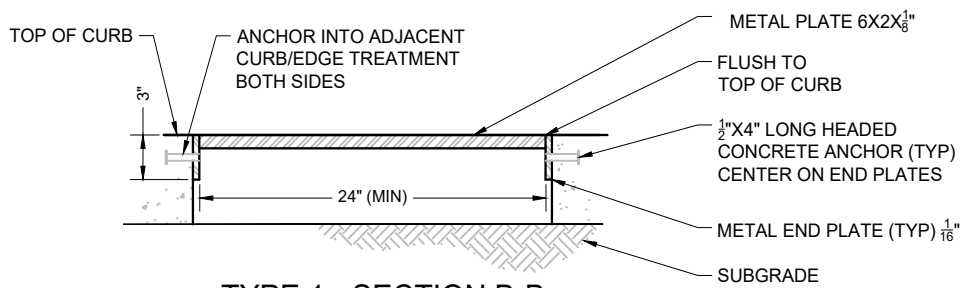

TYPE 1 - SECTION B-B

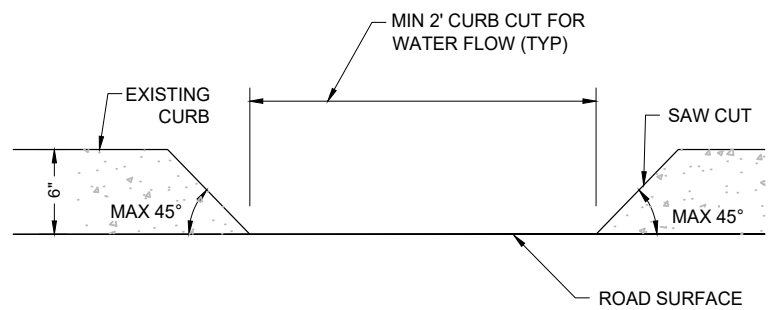

CURB OPENING - TYPE 2
ANGLED CURB CUT

- NOTES:**
1. DO NOT CUT DEEPER THAN ROAD SURFACE ELEVATION.
 2. ALL CURB OPENINGS SHALL BE MADE BY SAW CUT METHOD.
 3. GRIND EXPOSED METAL AND SEAL TO PROTECT FROM CORROSION.

DETAIL NO. .ID-02	STANDARD DETAIL ENGLISH	CURB OPENINGS	REVISED 01-29-2019	DETAIL NO. LID-02
-----------------------------	------------------------------------	----------------------	-----------------------	-----------------------------

2. CURB OPENINGS

Curb openings (LID-02 and LID-03) convey runoff into and out of LID features, such as swales or bioretention areas. This LID treatment can be retrofitted into an existing roadway, or can be built as part of new construction and can be used in almost any situation.

2.1 APPLICABILITY AND ADVANTAGES:

The clear openings are typically 2 feet wide. Curb openings are regularly used to convey flows from parking lots and streets into stormwater capture areas and LID facilities. They are the most common LID practice. For safety purposes, roadway design speeds, clear zone offsets, and the type of curb opening must be considered during the curb opening selection process.

- Metal grate curb openings can be designed to meet ADA standards while accommodating water flows and pedestrian traffic.
- Curb openings are useful in areas where the runoff source is not separated from a LID feature by a pedestrian path.
- Curb openings are relatively easy to maintain.

2.2 DESIGN CONSIDERATIONS

- By themselves, curb openings are not a LID treatment.
- The curb openings should be at least 24 inches wide to prevent clogging.
- When the curb cut is angled, it should have chamfered sides at 45 degrees, which is the maximum angle that can be achieved with typical concrete saws.

- The floor of the curb opening should slope toward the stormwater or LID element.
- A minimum 2-inch grade drop should be provided between the floor of the curb opening and the finished grade of stormwater element to allow positive drainage.
- The curb opening must be sized allow the design flow to pass without causing ponding in the adjacent roadway travel lane.
- The back slope of curb opening inlet should be armored to prevent erosion if a sediment trap is not also installed.

2.3 CONSTRUCTION CONSIDERATIONS

Curb cuts can be built as new construction or retrofitted into an existing roadways and ROWs. Either way, curb cuts require review and approval during the design and construction phases. Traffic control will typically be required during construction on public streets in accordance with the municipal requirements. The contractor may elect to remove an entire curb section and replace with a poured curb opening in lieu of using the curb-cut method.

2.4 MAINTENANCE

Curb openings should be inspected after storms of 0.5 inches or greater to make sure that they are not clogged with debris or sediments. While inspecting the curb openings, observations should also be made about the potential debris or sediment buildup in the collection element. View routinely for damage from vehicle strikes and schedule repairs as necessary.

2.5 COMPATIBILITY WITH OTHER LID PRACTICES

Curb openings can be implemented as an accessory to many LID and non-LID facilities. They can be used with vegetated/rock swales; stormwater harvesting systems; sediment traps; and bioretention systems to capture roadside stormwater.

2.6 SPECIFICATIONS

SECTION 341 - CURB OPENINGS

341.1 DESCRIPTION

Curb openings accept roadway and impervious surface stormwater runoff to flow into and release from associated other types of LID features such as vegetated swales, rainwater harvesting basins or bioretention areas. Curb openings can be retrofitted onto an existing roadway or they can be constructed as part of the original construction.

Except as herein stated, the requirements indicated in MAG Specifications 201, 215, 340, 401, and 505 are applicable to this specification for curb openings.

341.2 MATERIALS

All aprons and curb openings shall be completed in concrete. Aprons will follow MAG Specification 505. Curb openings should include a rock pad, riprap or protected inlet on side slope, and a concrete sediment trap on the downstream side.

10 LID TECHNICAL STANDARD DETAILS AND SPECIFICATIONS

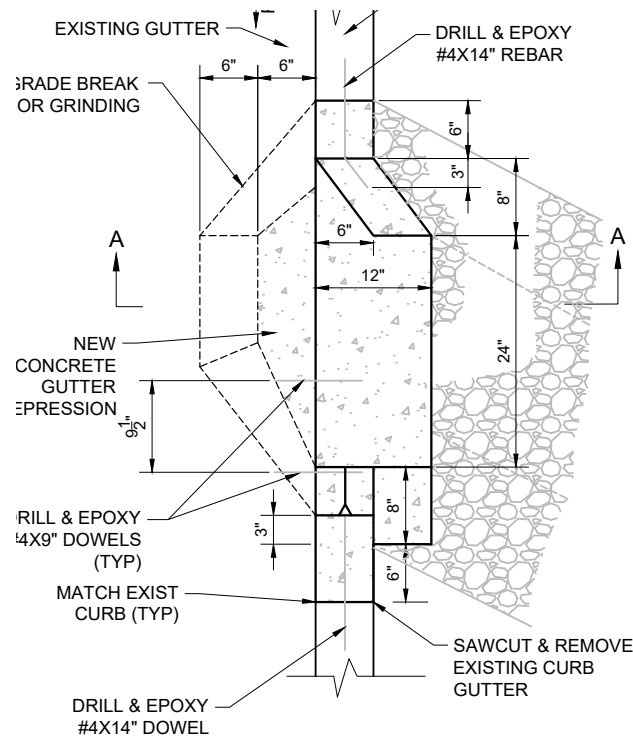

TYPE 3 - PLAN VIEW

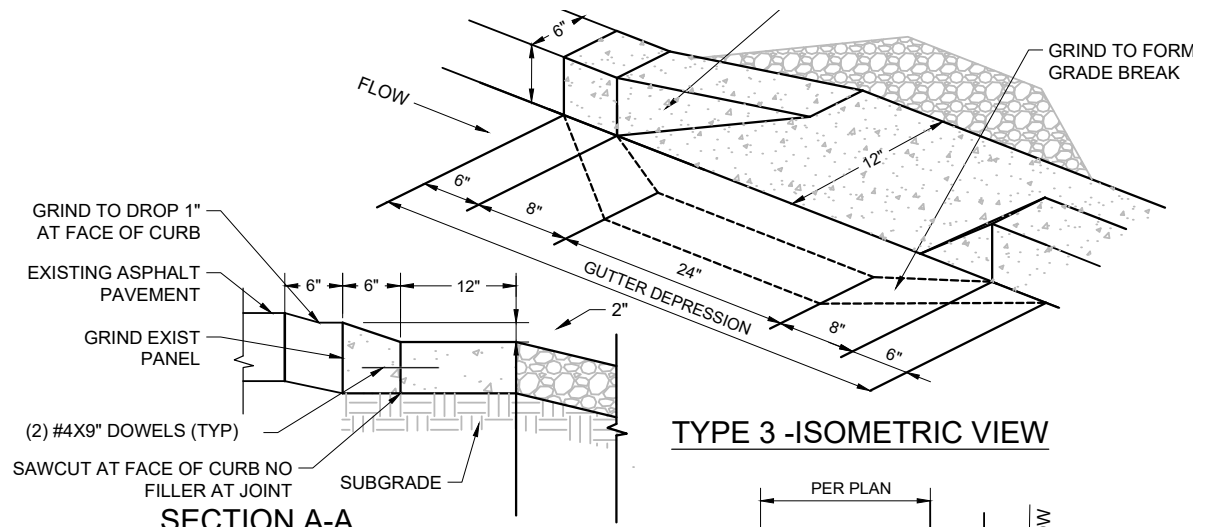

**SECTION A-A
CURB OPENING - TYPE 3
CONCENTRATED FLOW INLET**

TYPE 3 - ISOMETRIC VIEW

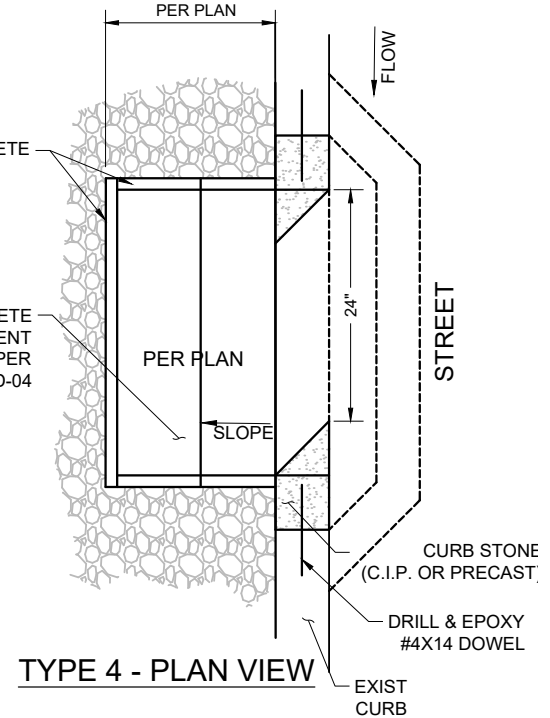
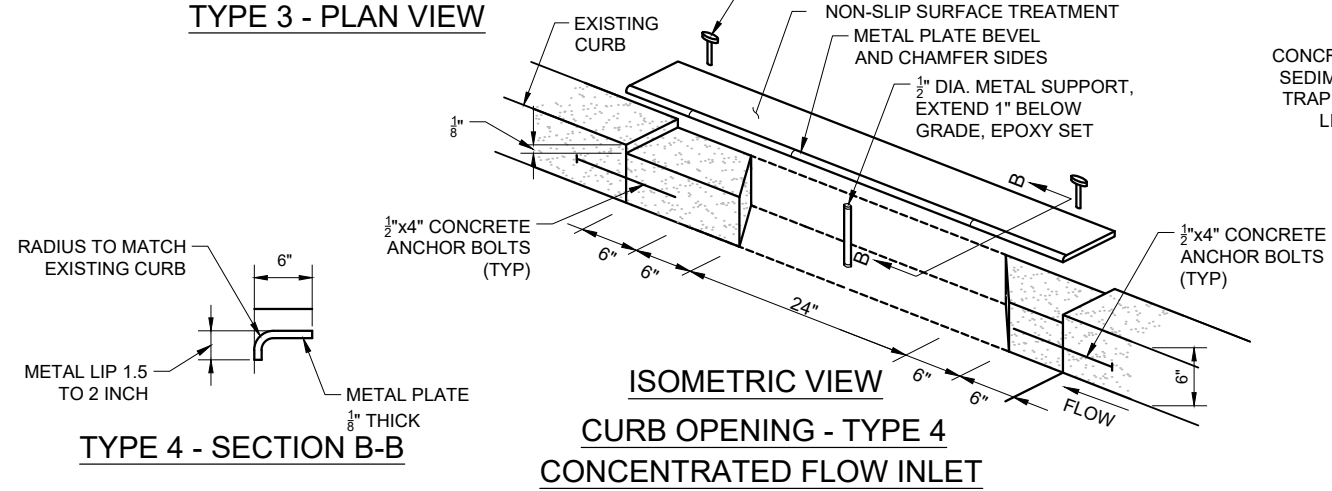

DETAIL NO. ID-03	STANDARD DETAIL ENGLISH	CURB OPENINGS	REVISED 01-29-2019	DETAIL NO. LID-03
----------------------------	------------------------------------	----------------------	-----------------------	-----------------------------

341.3 GENERAL

The minimum curb cut of 24 inches is recommended. The curb shall not be cut lower than 0.25 inch below the gutter. The flow entrance should drop a minimum 2 inches from the curb line. The curb cut will be done by the saw-cut method and have maximum chamfered sides at 45 degrees, but the curb cut may be vertical.

No curb may be lowered, or driveway constructed, which may be in any way dangerous or hazardous to pedestrian or vehicular traffic. Any curb opening on roadways with design speeds over 30 miles per hour (mph) will require a metal plate constructed on top of the entire curb opening. The plate shall meet current ADA standards; please refer to the ADA Design Guide.

All damage that occurs during the construction process shall be repaired in accordance with the MAG Specification 340. The additional costs will be incurred at the contractor's expense. All repairs must be completed within 24 hours.

The contractor is responsible for the quality of the curb opening and any related work therein and shall guarantee this work against failure for a period of 3 years. This guarantee does not cover damage resulting from accident, disaster, misuse, abuse, or modification of the curb opening. The contractor is responsible for traffic control per MAG Specification 401.

341.4 PAYMENT

Payment will be made for the applicable items at the contract unit prices bid in the proposal, and shall constitute full payment for furnishing all material, equipment, tools, labor and incidentals necessary to complete the work and for carrying out the maintenance provisions.

10 LID TECHNICAL STANDARD DETAILS AND SPECIFICATIONS

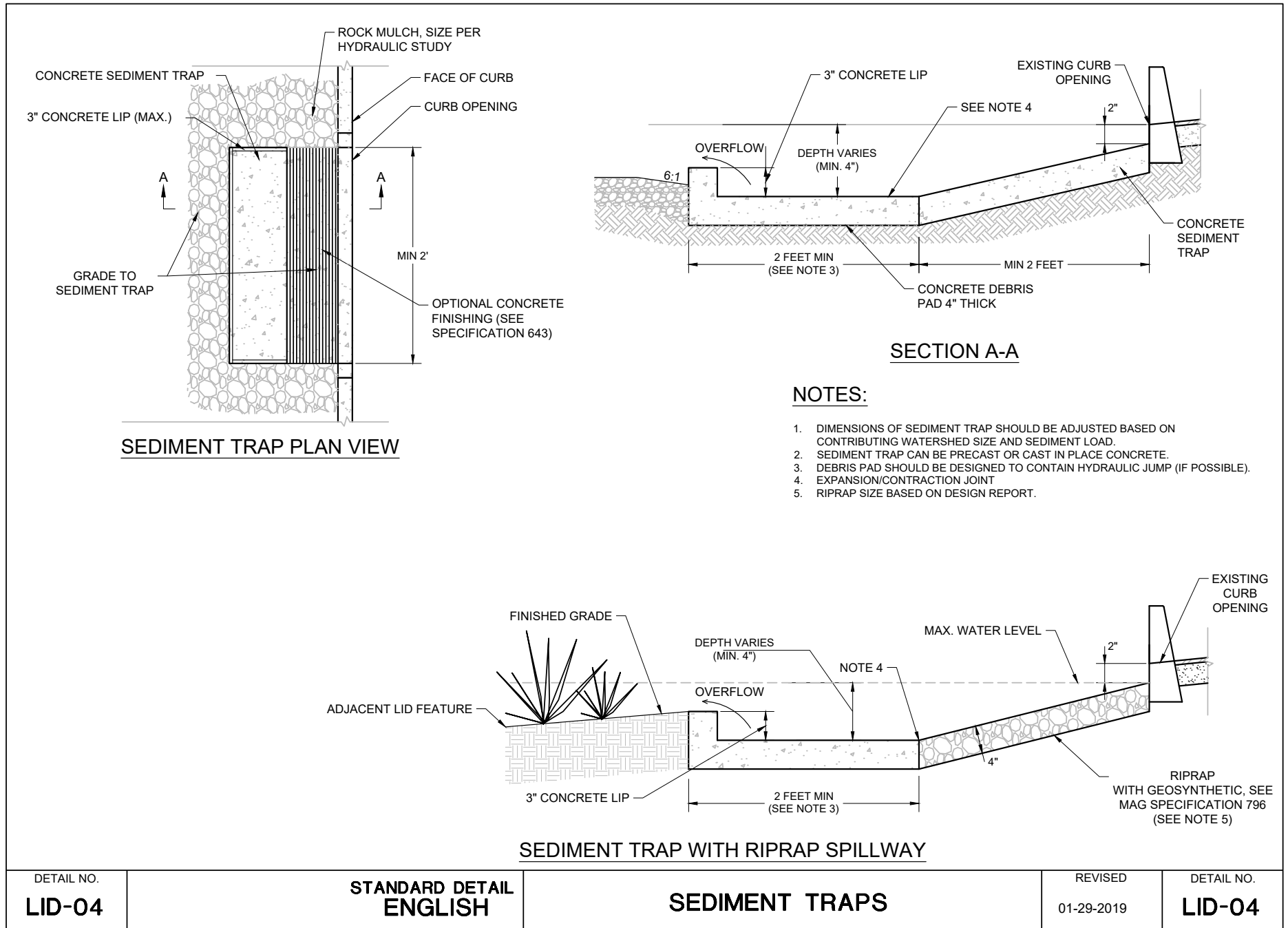

3. SEDIMENT TRAPS

Sediment traps (LID-04) should be installed at curb openings and/or inlets that receive concentrated stormwater flows. A sediment trap provides a collection point for sediment and other debris before runoff enters a stormwater capture or LID facility. Sediment traps facilitate individual component and system maintenance.

3.1 APPLICABILITY AND ADVANTAGES

Sediment traps are applicable to areas with concentrated runoff flowing into a stormwater capture or LID facility. Traps are generally used as an accessory to another LID element or storage basin.

Sediment traps:

- Reduce sedimentation of adjacent basins and LID features.
- Reduce erosion and disperse energy.
- Reduce maintenance efforts because the concrete debris pad facilitates easy removal of sediment and debris.
- Improve the overall LID system function and life cycle/longevity.

3.2 DESIGN CONSIDERATIONS

- The debris pad of the sediment trap should be as flat as possible to aid in the removal of debris. A 3-inch concrete lip should be constructed on three sides to reduce maintenance and encourage sediment deposition.
- The flow path length-to-width ratio should be 3 to 1 or less because a higher flow path length to width ratio increases fine sediment removal.

- The sediment trap flow path and debris pad can be built as a single unit from poured concrete or from precast units.
- A riprap bottom is not recommended because they are difficult to clean. Riprap or appropriately sized rock should be used to armor the sediment trap side slopes.
- The optimal sediment trap design would be long enough so that the hydraulic jump occurs within the feature, the length of the hydraulic jump and tailwater depth can be calculated using the equations in FCDMC Hydraulics Manual (Reference 13) given below:

$$F_{R1} = \frac{V_1}{(gY_1)^{1/2}}$$

$$Y_2 = \frac{1}{2}Y_1 \left[\sqrt{1 + 8F_{R1}^2} - 1 \right]$$

$$L_j \approx 6Y_2$$

Where:

- F_{R1} = Froude's number upstream of hydraulic jump
- V_1 = initial upstream velocity (ft/sec)
- Y_1 = initial upstream flow depth (ft)
- Y_2 = tailwater depth downstream from Y_1 (ft)
- g = acceleration of gravity (32.2 ft/sec²)
- L_j = length of hydraulic jump (ft/ft)

- Sediment traps can have adjacent landscaping or can have grasses within the concentrated flow portion of the facility.

3.3 CONSTRUCTION CONSIDERATIONS

Flows should be diverted around the sediment trap to protect it from inundation during construction. Excavated material should be stored such that it cannot be washed back into the sediment trap or downstream, if a storm occurs during construction.

3.4 MAINTENANCE

Sedimentation or debris should be removed at least every 6 months and after storms of 0.5 inches or greater. The debris pad to should be completely clean after maintenance is finished.

3.5 COMPATIBILITY WITH OTHER LID PRACTICES

Sediment traps must be utilized as an accessory with another LID facility or conveyance structure. They typically are designed in conjunction with curb openings and vegetated/rock bioswales.

10 LID TECHNICAL STANDARD DETAILS AND SPECIFICATIONS

3.6 SPECIFICATIONS

SECTION 643 - SEDIMENT TRAPS FOR LID FACILITIES

643.1 DESCRIPTION

This work shall consist of supplying and constructing a sediment trap outlet in catch basins with additional sump depth as shown on the plans, profiles and details and as specified herein. This work shall be done in accordance with MAG Specifications 201, 215, 220, 425, and 430, except as herein provided.

643.2 MATERIALS

Materials for sediment trap shall are specified in MAG Specification 505, 703, 705, and 725.

643.3 GENERAL

The sediment trap shall be constructed with a minimum 8-inch depth sump, measured from the curb opening the concrete floor. The sediment trap shall be constructed in accordance with the diameter and details shown on the project plan and details. A 3-inch concrete lip will be placed around the splash pad to support maintenance activities. Optional concrete finishing is achieved by roughening concrete surface with hard broom or rake and seeding the wet concrete surface with 0.25-inch decomposed granite.

The sediment trap outlet and all associated connection hardware necessary to complete the sediment trap outlet within the structure shall be completed as shown on the detail sheets of the plans and/or as directed by the Engineer.

643.4 PAYMENT

The unit of measure for the sediment trap will be per each and the payment will be made at the contract unit price per each specified, which will include excavation, shoring, backfill, compaction, rip-rap installation, and all labor, materials, tools, equipment and incidentals needed to complete work specified. Refer to MAG Specification 206, 215, and 220 for those items that are included in the sediment trap construction.

THIS PAGE LEFT INTENTIONALLY BLANK

10 LID TECHNICAL STANDARD DETAILS AND SPECIFICATIONS

GENERAL NOTES (BASIN):

1. SURFACE WATER MUST DRAIN WITHIN 36 HOURS.
2. INFILTRATION AREA DEPTH AND WIDTH DETERMINED BY PERCOLATING WITHIN 72 HOURS. WIDTH MUST EXCEED DEPTH.
3. DEDICATED OUTFLOW MAY BE REQUIRED FOR THIS FEATURE.
4. FOR OPTIONAL PERFORATED UNDERDRAIN (SEE SPECIFICATION 622)
5. REFER TO AASHTO ROADWAY DESIGN BOOK FOR CLEAR ZONE REQUIREMENTS.
6. NO PLANTINGS IN THE CONCENTRATED FLOW INLET.
7. OPTIONAL SEDIMENT TRAP AT CONCENTRATED FLOW INLET.

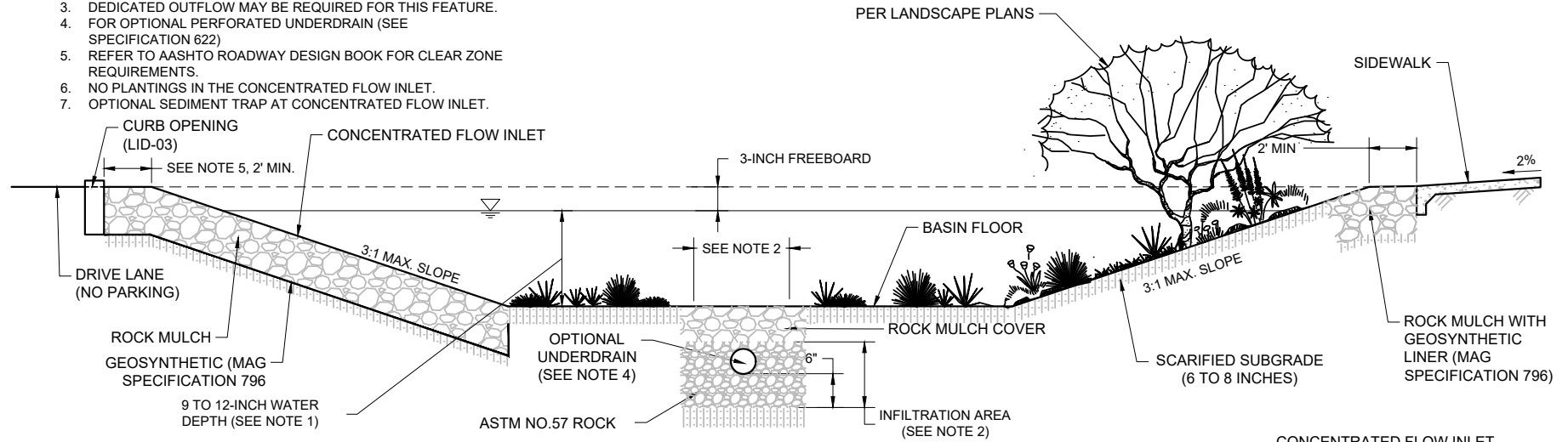

STORMWATER HARVESTING BASIN SECTION WITH CUT THROUGH CONCENTRATED FLOW INLET

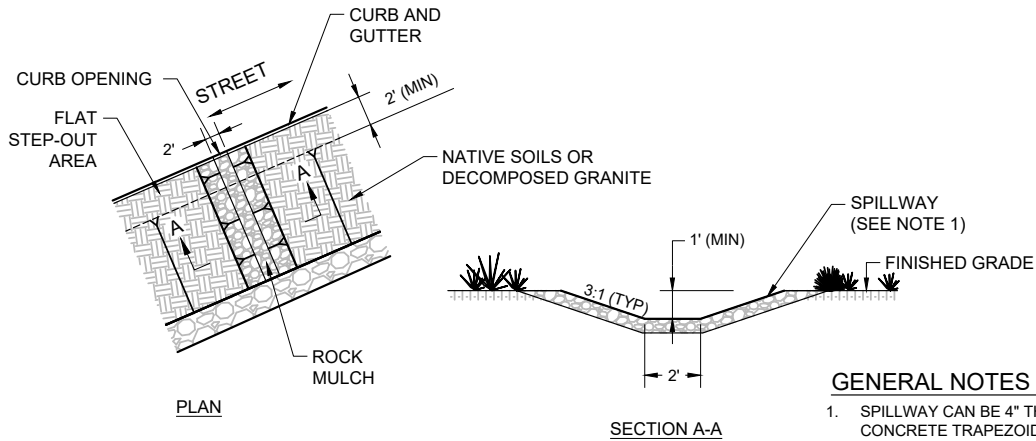

GENERAL NOTES (INLET):

1. SPILLWAY CAN BE 4" THICK CONCRETE TRAPEZOID SCUPPER 6" DEEP OR ROCK SPILLWAY BASED ON DESIGN.

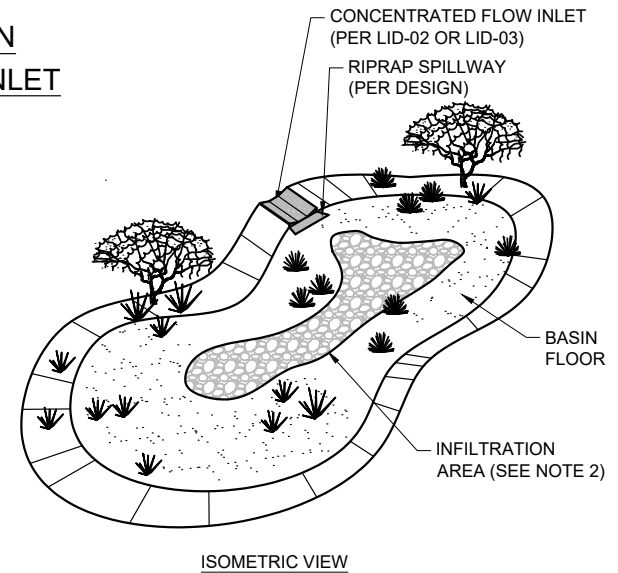

RIPRAP SPILLWAY (PLAN & SECTION)

DETAIL NO. LID-05	STANDARD DETAIL ENGLISH	STORMWATER HARVESTING BASINS	REVISED 01-29-2019	DETAIL NO. LID-05
-----------------------------	------------------------------------	-------------------------------------	-----------------------	-----------------------------

4. STORMWATER HARVESTING BASINS

Stormwater harvesting basins (LID-05), also known as rain gardens, are shallow vegetated earthen depressions that collect stormwater and cleanse it prior to the water percolating into the subsurface. These differ from typical retention basins in that they provide subsurface storage within the constructed facility. An infiltration trench is designed in the center of the storage area so that surface water is infiltrated within 36 hours.

Generally, harvesting basins are utilized in onsite planning for stormwater detention. They can be constructed at any size and for various developments, including residential, commercial, or industrial land uses. Harvesting basins should be built adjacent to impervious areas like parking lots and recreational areas such as sport courts. When there is adequate ROW, basins may also be incorporated as roadway enhancements. Harvesting basins are typically landscaped.

4.1 APPLICABILITY AND ADVANTAGES

- Harvesting basins may accomplish a portion of the onsite detention requirements, if designed and maintained with that intent.
- Harvesting basins should be built immediately adjacent to localized runoff sources/impervious areas (e.g. parking areas, driveways, and rooftops) in lieu of constructing a large, centralized on-site basin.
- Harvesting basins can be retrofitted into sites with or without existing drainage features, are compatible features when adjacent to parking and roadways, easily fit within natural areas, and

can be used to achieve drainage volume credit in some municipalities, if designed and approved to meet those requirements.

- Harvesting basins are relatively simple to build, relatively easy to maintain, and scalable in size.
- Harvesting basins can be multifunctional, providing wildlife habitat and creating a “softer” aesthetic for streets and roads by incorporating additional landscaping and vegetation.
- Harvesting basins enhance stormwater infiltration, potentially improving water quality.
- Harvesting basins can reduce the reliance on potable water sources for landscaping irrigation for other portions of the project area, depending on the landscape design and the volume and pattern of stormwater collection.
- Harvesting basins create planting conditions that encourage enhanced vegetation growth that yields cooling properties for adjacent land areas and the Phoenix Metropolitan Area heat island phenomenon.

4.2 DESIGN CONSIDERATIONS

- There may be a need to design the basin with an underdrain or overflow drain option if the soils have low infiltration rates or if the anticipated capture volume exceeds the holding capacity of the basin and the infiltration trench. Please refer to the LID Storage and Infiltration tables located in Appendix B to determine the design volume and percolation rates of underground systems. The overflow outlet should be located at the downstream end of a drainage basin. Subterranean outlets associated with the underdrain must be connect to an appropriate

downstream drainage facility, LID element, and/or underground stormwater collection system.

- The first flush rainfall (0.5 inch) can be used to determine the design stormwater volume in accordance with the local standards. The allowable surface storage of a harvesting basin should be 9 – 12 inches with a recommended freeboard of 3 inches. Stormwater harvesting basins should drain surface ponding in less than 36 hours in accordance with the local standards for vector control purposes. The underground runoff volume should percolate within 72 hours so the feature remains effective during the monsoon.
- Stormwater harvesting basins may accept distributed flow along some or all perimeter sides from areas like parking lots or landscape areas. If the basin slope can be designed to be flatter than 3 to 1, the basin sides accepting the distributed flow may be of vegetated earthen construction. Slopes steeper than 3 to 1 should be rock-lined based on the engineering analysis.
- When the stormwater harvesting basin is located next to a travel lane, the Engineer must refer to the AASHTO Roadway Design Book for clear zone requirements (Reference 14).
- The underground work will likely require a special inspection during construction.
- For steep slopes and inlets where flow is concentrated, scuppers or riprap spillways should be designed to prevent erosion.
- Harvesting basins should be located as close to the runoff sources as possible and be distributed throughout the site instead of relying on one large basin to capture the flows.

10 LID TECHNICAL STANDARD DETAILS AND SPECIFICATIONS

To facilitate revegetation, soil fertility testing should be conducted on exposed soils to determine what nutrients/amendments may be needed to foster vegetation growth. Imported soils are not encouraged.

- Because of their association with new or existing development, basin sides are typically landscaped to improve the aesthetics of the element, to match an existing landscape character, and/or to reduce potential erosion on the side slopes. The landscaping treatment can range from a native, drought-tolerant palette to a more ornamental landscaping approach commensurate with urban development. Soil building materials such as organic mulch, biota, and fertilizers may be incorporated into the planting area to improve vegetative success; the need for these can be identified through soil fertility testing and by specifically defining the landscaping objectives and performance expectations.
- Plant selections should consider the location of the plants within the basin and their potential frequency of inundation or for damage. In general, installed plantings (not native seeding) will require some degree of supplemental watering to get the plants established. Watering is typically accomplished through an underground irrigation system whose volume may be reduced over time and/or abandoned once the plants have been established, depending on the success of the landscape installation and the volume and pattern of stormwater collection.

4.3 CONSTRUCTION CONSIDERATIONS

Filter fabric should not be used in stormwater harvesting basins. Compaction should be avoided during construction. The construction area should be fenced off with construction fencing or silt fencing to prevent compaction of soils by construction equipment or traffic during construction of surrounding improvements. At a minimum, the bottom grade and side slopes should have the top 6 – 8 inches scarified. A percolation test should be completed before the construction of the underground storage area to determine if the site soils will perform as anticipated and/or if an underdrain is necessary. Vegetation should be selected to thrive within the anticipated hydrological regime and infiltration rates of the harvesting basins to minimize long-term maintenance commitments.

4.4 MAINTENANCE

After every storm greater than 0.5 inches, or semiannually at a minimum, the harvesting basins should be checked for erosion, sediment, debris, litter, and clogging. If there is standing water, the perforated underdrain should be checked for clogs and cleaned as necessary. Section 3 identifies the maintenance practices for the landscape element of this LID treatment. If an altered water flow pattern, erosion, or plant die-off is observed, these should be corrected in kind, at a minimum, and/or evaluated for further corrective measures.

4.5 COMPATIBILITY WITH OTHER LID PRACTICES

Stormwater harvesting basins are harmonious with and can seamlessly incorporate other LID techniques such as curb openings, bioretention systems, and sediment traps. If it is determined that a harvesting basin's functional operation will be insufficient, this LID element must be used in combination with other LID techniques.

4.6 SPECIFICATIONS

SECTION 641 – STORMWATER HARVESTING BASIN

641.1 DESCRIPTION

Work under this item includes the installation of a stormwater harvesting basin and associated appurtenances. Except as herein stated, the requirements specified for MAG Specifications 201, 215, 220, 425, 430, and 796 are applicable to this specification.

641.2 MATERIALS

See MAG Specifications 201, 215, 220, 425, 430, and 796.

641.3 GENERAL

641.3.1 Temporary Erosion Control

Install all temporary erosion control measures prior to site disturbance. Install storm drain inlet protection to prevent clogging of the storm drains and increases in sediment loads to downstream stormwater facilities or waterbodies.

Inspect erosion control measures at least once a week and after each rainfall event. Make any required repairs immediately.

Erosion control devices shall be maintained until the site is stabilized, as determined by the Engineer.

If sediment is introduced into the basin during or immediately following excavation, the sediment will need to be removed from the basin or underdrain prior to initiating the next step in the construction process.

641.3.2 Excavation, Backfilling, and Grading

Refer to MAG Specification Section 215 – Earthwork for Open Channels, except as follows:

If an underdrain is required per the construction documents excavate the underdrain to the specified depth (elevation) and follow proposed Special Provision 622. All subgrade material below the specified elevation shall be left undisturbed, unless otherwise directed by the Engineer. Material excavated from the basin shall be disposed of on-site at locations (temporary stockpile areas) designated by the Engineer.

641.3.3 Construction Sequence Scheduling

An implementation schedule should be included as part of the erosion control plan to identify the order of operations for construction activities. This is particularly important when constructing stormwater best management practices (BMPs) that are designed to infiltrate stormwater runoff.

There are many construction activities which may contribute to the failure of a stormwater BMP if they are not planned for accordingly. The following items should be considered in developing an implementation schedule for a project:

- A. Perform continuous inspection of temporary construction access to ensure that it is providing adequate erosion and sedimentation control for the construction site.
- B. Install erosion protection along the perimeter of the site to prevent sediment from leaving the site during the construction process. Protection should be installed at a uniform elevation and constructed so that flow cannot bypass the ends.
- C. All down-gradient perimeter sediment-control BMPs (e.g. temporary outlet controls) must be in place before any up-gradient land-disturbing activity begins.
- D. Rough grade the site leaving the basin area undisturbed until the contributing drainage area has been completed and the site is stabilized.
- E. Construct the road/site improvements in a manner that minimizes adverse impacts to the location and function of the stormwater BMPs. For example, ensure that construction access or equipment staging areas do not conflict with the final location of the basin.
- F. Perform all other site improvements in a manner that minimizes adverse impacts to the location and function of the stormwater BMPs.
- G. Final grade the site. Grading of the basin shall be accomplished using low-impact earth-moving equipment to prevent compaction of

the underlying soils. Wide-tracked vehicles such as backhoes, small dozers and sld-steers are recommended. Excavating equipment should operate from the side of the basin to the extent feasible. If excavation leads to substantial compaction of the subgrade, the first several feet shall be removed and replaced with a blend of topsoil and sand to promote infiltration and plant growth.

- H. Stabilize the site by implementing the landscaping plan.
- I. Install any required erosion control berms, ditch checks, and other semi-permanent and permanent erosion control measures.
- J. Remove the temporary erosion and sediment controls after the basin is stabilized per the Engineer's approval. It is important for the basin to be stabilized before receiving stormwater flow.

641.4 MEASUREMENT AND PAYMENT

The unit of measure for the stormwater harvesting basin will be cubic yards. The payment will be in accordance with the following MAG Specification Sections, including all labor, materials, tools, equipment and incidentals needed to complete work specified.

- Section 201 – Clearing and Grubbing
- Section 215 – Earthwork for Open Channels
- Section 220 – Riprap Construction
- Section 430 – Landscaping and Planting
- Section 796 – Geosynthetics

10 LID TECHNICAL STANDARD DETAILS AND SPECIFICATIONS

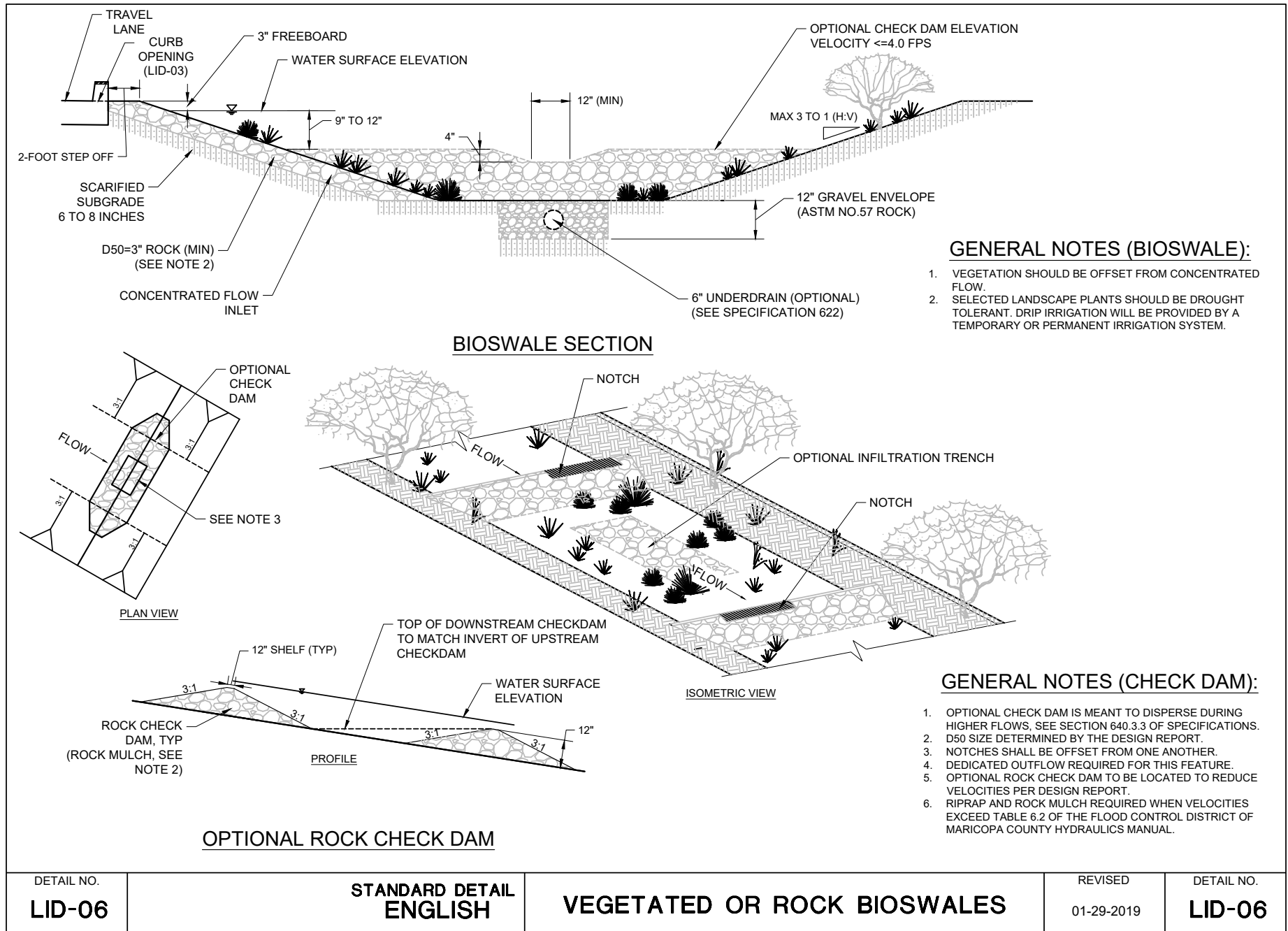

5. VEGETATED OR ROCK BIOSWALES

Vegetated/rock swales (LID-06) are open, shallow channels that may have trees, grasses, and other low-lying vegetation covering the swale bottom and side slopes, with pervious surface plating materials such as decomposed granite, larger rock, and/or mulch. Vegetated or rock bioswales are designed to slow the flow of runoff to downstream discharge points through various optional methods such as a meandering layout, roughened surfaces, plants, and check dams. Vegetated bioswales should encourage and accommodate additional landscaping within the feature.

When landscaped, vegetated swales may provide additional pollutant removal through infiltration and vegetation uptake. Bioswales can provide water harvesting opportunities, depending on the site conditions and their hydraulic requirements. When properly designed, swales may allow percolation of cleansed storm water into the ground.

Depending on the location, the preferred vegetation may be limited to grasses and forbs and/or arid-adapted species that are drought-tolerant and don't require irrigation after establishment. Other locations may consider a different plant palette that is also drought tolerant but that requires limited irrigation. In all cases, care must be taken when selecting plant materials used in the bottom of bioswales; these plants must also be able to accommodate occasional inundation, as they may be in water until infiltration has occurred.

5.1 APPLICABILITY AND ADVANTAGES

Rock bioswales are usually placed inline within a storm drain system and are intended to slow down and infiltrate runoff. Specifically, swales:

- Slow the water which minimizes and decreases runoff, reduces erosion, and allows filtration (cleansing) of stormwater.
- Provide a method of water harvesting that promotes plant growth, thereby reducing the reliance on potable water for landscape irrigation; they also capture pollutants in stormwater.
- Produce planting conditions that encourage enhanced vegetation growth, providing cooling for adjacent land areas and helping to reduce the Phoenix Metropolitan Area heat island phenomenon. The aesthetics of the swales are enhanced when landscaped.
- Are relatively simple to build, cost-effective, and relatively easy to maintain.
- Can become tiered/stepped features for detaining stormwater where longitudinal grades are steep.

5.2 DESIGN CONSIDERATIONS

- Prevention of erosion of in-situ soils should be paramount during the design. Rock, vegetation, and/or organic mulches can be used to stabilize the surface.
- Subterranean outlets associated with the underdrain must connect to an appropriate

downstream drainage facility, LID element, and/or underground stormwater collection system.

- By building obstruction structures perpendicular to the flows (i.e., check dams and weirs), flow velocities are reduced and infiltration is improved.
- Side slopes of bioswales should not be steeper than 3 to 1 for safety, erosion, and maintenance purposes. If located adjacent to sidewalks or parking lots, a 2-foot level shelf must be created along those elements as a recovery area. Swale bottom widths should be less than 8 feet if meandering is desired.
- The bioswale can be designed as a trapezoid. The flow depth and limiting velocity should be recommended as part of the design report. If the velocity is less than 1 foot per second (fps), scour and sediment transport of fine materials will be reduced. The longitudinal slope can be reduced by either increasing the longitudinal length or by meandering the flow path.
- May require rock covering, more robust soil cover, or soil amendments to counter the erosion potential for areas with steeper slopes.
- Sediment traps (LID -04) should be used where concentrated runoff enters the bioswale to dissipate flow velocities and to uniformly distribute flows across the channel. Flow spreaders may also be incorporated into the improvements.
- Energy dissipation should be designed at the toes of each vertical drop if energy dissipators, check dams, or similar structures are used.

10 LID TECHNICAL STANDARD DETAILS AND SPECIFICATIONS

- The maximum flow velocity from the first flush storm event (0.5 inches) should be less than 2 fps so that vegetation is not damaged and sediments can be deposited. The Manning's "n" coefficient should be increased to achieve reduction in velocities. The equation below by Phillips and Ingersoll (1998) can be used to estimate Manning's "n" coefficient for channels with a median bedding material diameter (d_{50}) that ranges from 0.28 to 0.36 feet (Reference 15):

$$n = \frac{0.0926R^{1/6}}{1.46 + 2.23 \log\left(\frac{R}{d_{50}}\right)}$$

where

d_{50} = Intermediate diameter of bed material (feet) that equals or exceeds that of 50 percent of the particles (i.e. median grain size).

R = Hydraulic radius (ft)

- The residence time in a swale should be typically 10 minutes to optimize pretreatment and sediment removal. The swale length can be calculated as below (See Reference 5):

$$L = 600V_{wq}$$

L = swale length (ft)

V_{wq} = design flow velocity (ft/sec)

- When landscaped, the design objective is typically to improve the aesthetics of the swale and/or to match the existing landscape character of the surrounding lands. The landscaping treatment can range from a native, drought-tolerant palette to a more ornamental landscaping approach commensurate with the surrounding character. Soil building materials

such as organic mulch, biota, and fertilizers may be incorporated into the planting area to improve vegetative success; the need for these can be identified through soil fertility testing and by specifically defining the landscaping performance expectations. Plant selections need to consider the location of the plants within the bioswale and their potential frequency for inundation, damage, or flow blockage. In general, installed plantings (not native seeding) require supplemental watering to get the plants established. Watering is typically accomplished through an underground irrigation system whose volume may be reduced over time and/or abandoned once the plants have been established, depending on the success of the landscape installation and the volume and pattern of stormwater collection.

5.3 CONSTRUCTION CONSIDERATIONS

The areas upgradient of a bioswale must be stabilized prior to the construction of the bioswale. If the upslope area has not been stabilized, temporary or permanent erosion and sediment control measures must be installed. Equipment passes should be avoided in the bottom of the swale to prevent compaction. If the subgrade soil is compacted, it should be scarified to a depth of 6 – 8 inches to loosen the soil particles. After rough grading, the bioswale should be fine-graded to avoid nonconformities. Angular rock can be placed following fine grading to provide a roughened surface to slow flow velocities and to protect the subgrade. Placing rock and seeding will improve overall aesthetics and support revegetation.

5.4 MAINTENANCE

After every storm greater than 0.5 inches or annually at a minimum, swales should be checked for erosion, sediment, debris, litter, and clogging. If the sediment level inhibits vegetation or reduces capacity, the sediment should be removed. A sediment trap (LID-04) could be added at the flow concentration inlet to reduce maintenance and increase long-term performance. Section 3 identifies the maintenance practices for the landscape element of this LID treatment. If an altered water flow pattern, erosion, or plant die-off is observed, these should be corrected in kind, at a minimum, and/or evaluated for further corrective measures.

5.5 COMPATIBILITY WITH OTHER LID PRACTICES

Vegetated/rock bioswales often are designed in conjunction with curb openings or permeable pavements. Overflow structures are required when the system is connected to a downstream drainage facility or bioretention element. The bioswales should be connected to a proper discharge facility if designed for smaller storm events.

5.6 SPECIFICATIONS

SECTION 640 - VEGETATED OR ROCK BIOSWALES

640.1 DESCRIPTION

Work under this item includes the installation of vegetated and/or rock bioswales and associated appurtenances. Except as herein stated, the requirements specified for MAG Specifications 201, 215, 220, 425, 430, and 796 are applicable to this specification.

640.2 MATERIALS

See MAG Specifications 201, 215, 220, 425, 430, and 796.

640.3 CONSTRUCTION METHODS

640.3.1 Temporary Erosion Control

Install all temporary erosion control measures prior to site disturbance.

Install storm drain inlet protection to prevent clogging of the storm drains and increases in sediment loads to downstream stormwater facilities or waterbodies.

Inspect erosion control measures at least once a week and after each rainfall event. Make any required repairs immediately.

Erosion control devices shall be maintained until the site is stabilized, as determined by the Engineer.

If sediment is introduced into the swale during or immediately following excavation, the sediment will need to be removed from the vegetated bioswale or underdrain prior to initiating the next step in the construction process.

640.3.2 Swale Excavation, Backfilling, and Grading

Refer to MAG Specification Section 215 – Earthwork for Open Channels, except as follows:

If the vegetated bioswale is used for runoff conveyance during construction, initial grading of the swale shall be performed in conjunction with rough grading of the site. Once construction in the contributing drainage area has been completed and the site is stabilized, re-grade and restore the bioswale to ensure functionality.

If an alternative temporary sediment basin facility is being provided before discharge to the bioswale, grading and construction of the vegetated bioswale should not be connected until the contributing drainage area has been completed and stabilized.

If an underdrain is required per the construction documents excavate the underdrain to the specified depth (elevation) and follow Specification 622. Typical details would be required when connected to a downstream drainage facility. All subgrade material below the specified elevation shall be left undisturbed, unless otherwise directed by the Engineer.

Materials should be graded and contoured onsite when possible or excavated from the vegetated swale shall be disposed of on-site at locations (temporary stockpile areas) designated by the Engineer.

The perforated pipe (underdrain) shall be laid directly on the gravel bed. Grade and alignment shall not vary from the prescribed grade by more than 0.1 foot at any point. The joints between sections of pipe shall be connected in a fashion acceptable to Engineer. Once the pipe is in place, it shall be covered immediately with open-graded stone material as specified in the construction documents. The material shall be of uniform depth on either side of the pipe. Special inlets and special devices at the outlet end of the pipe shall be constructed as shown in the plans.

640.3.3 Check Dams

Refer to Specification 644 for check dam construction. Maximum spacing between check dams should be such that the toe of the upstream dam is at the same elevation as the top of the downstream dam. The maximum height of the dam should not exceed 2 feet.

640.3.4 Construction Sequence Scheduling

An implementation schedule should be included as part of the erosion control plan to identify the order of operations for construction activities. This is particularly important when constructing stormwater BMPs that are designed to infiltrate stormwater runoff. There are many construction activities which may contribute to the failure of a stormwater BMP if they are not planned for accordingly. The following items should be considered in developing an implementation schedule for a project:

- A. Perform continuous inspection of temporary construction access to ensure that it is providing adequate erosion and sedimentation control for the construction site.
- B. Install erosion protection along the perimeter of the site to prevent sediment from leaving the site during the construction process. Protection should be installed at a uniform elevation and constructed so that flow cannot bypass the ends.
- C. All down-gradient perimeter sediment-control BMPs (e.g. temporary outlet controls) must be in place before any up-gradient land-disturbing activity begins.
- D. Rough grade the site leaving the vegetated bioswale area undisturbed until the contributing drainage area has been completed and the site is stabilized.

10 LID TECHNICAL STANDARD DETAILS AND SPECIFICATIONS

- E. Construct the road/site improvements in a manner that minimizes adverse impacts to the location and function of the stormwater BMPs. For example, ensure that construction access or equipment staging areas do not conflict with the final location of the vegetated swale.
- F. Perform all other site improvements in a manner that minimizes adverse impacts to the location and function of the stormwater BMPs.
- G. Install any required erosion control blanket, ditch checks, and other semi-permanent and permanent erosion control measures.
- H. Stabilize the site by implementing the landscaping plan.
- I. Remove the temporary erosion and sediment controls after the swale is stabilized per the Engineer's approval. It is important for the bioswale to be stabilized before receiving stormwater flow.

640.4 MEASUREMENT AND PAYMENT

The unit of measure for vegetated or rock bioswales will be linear feet. The payment will be in accordance with the following MAG Specification Sections, including all labor, materials, tools, equipment and incidentals needed to complete work specified.

- Section 201 – Clearing and Grubbing
- Section 215 – Earthwork for Open Channels
- Section 220 – Riprap Construction
- Section 430 – Landscaping and Planting
- Section 796 – Geosynthetics

SECTION 644 - CHECK DAMS FOR LOW IMPACT DEVELOPMENT FACILITIES

644.1 DESCRIPTION

Work under this item includes the installation of check dams to slow and hold water flow in LID facilities. Except as herein stated, the requirements specified for MAG Specifications 201, 211, 215, 220, and 301 are applicable to this specification.

644.2 MATERIALS

The stone shall meet the requirements set forth in the design plans or modified in the special provisions.

644.3 GENERAL

644.3.1 Construction Requirements:

Stone Check Dam: Construct the check dam with washed angular rock with D50 of 3 inches minimum (or approved equal) with side slopes of 3 to 1. Modification to this layout need to be approved by the Design Engineer. Place the stone so that it completely covers the width of the area and sides per the detail on the drawings. Form the overflow notch so that top of the outlet crest is approximately 4 inches lower than the outer edges.

Maximum spacing between check dams should be such that the toe of the upstream dam is at the same elevation as the top of the downstream dam. The maximum height of the dam should not exceed 2 feet. Mechanical placement required to achieve complete coverage of swale and to ensure that center of dam is lower than edges.

644.4 MEASURE AND PAYMENT

The unit of measure and payment for stone check dam will be made per cubic yard and include installation, setting, and leveling of stone and all labor, materials, tools, equipment and incidentals needed to complete the work specified.

THIS PAGE LEFT INTENTIONALLY BLANK

10 LID TECHNICAL STANDARD DETAILS AND SPECIFICATIONS

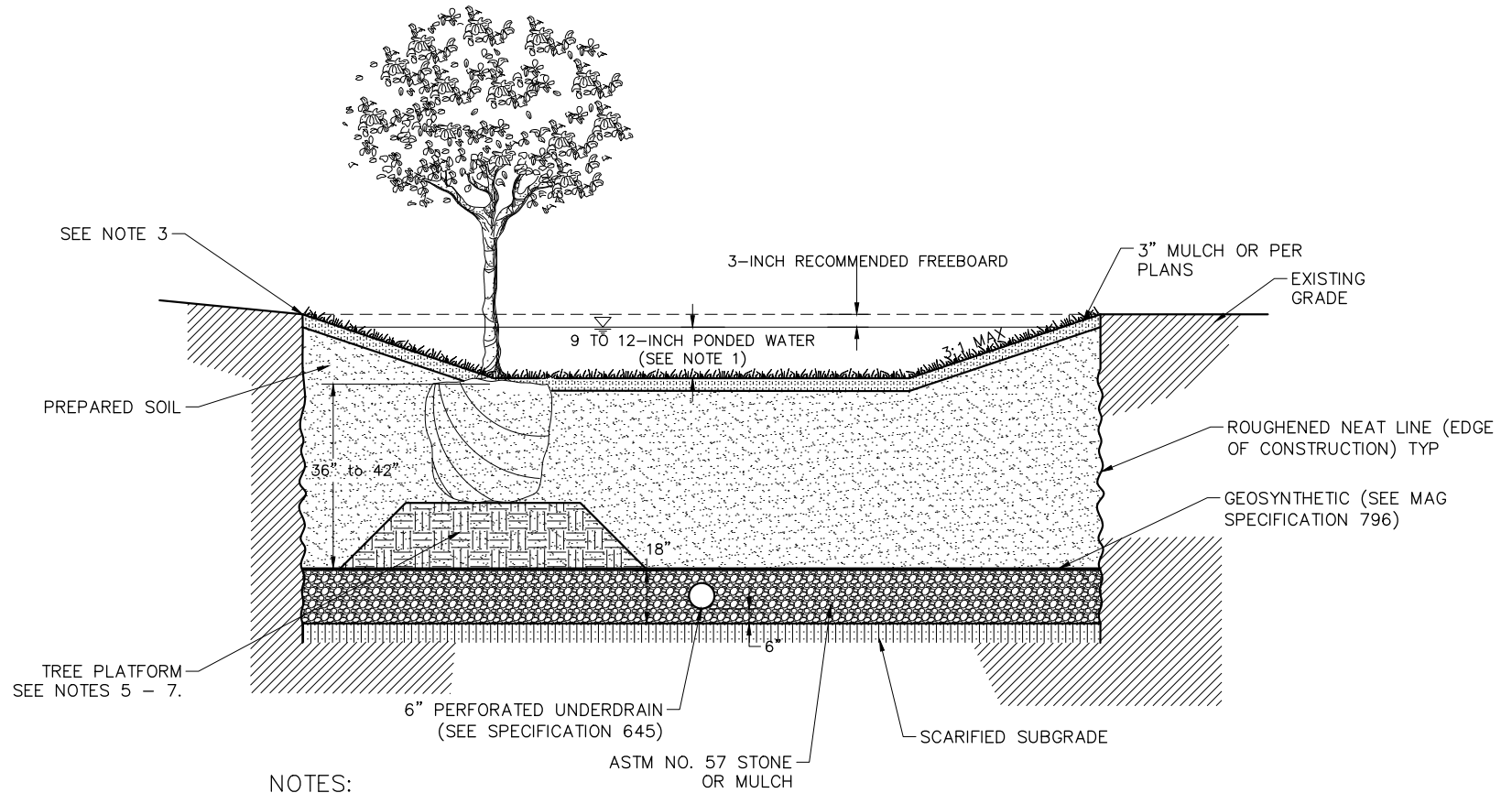

NOTES:

1. SURFACE PONDED WATER MUST PERCOLATE WITHIN 36-HOURS.
2. MINIMUM DEPTH OF 36 TO 42 INCHES TO ACCOMMODATE 48-INCH BOX TREE PLANTING.
3. SEE SPECIFICATION 645 FOR BUILDING SETBACK DISTANCES.
4. INTENDED TO CAPTURE SUBWATERSHED, DEDICATED OUTLET STILL REQUIRED.
5. TREE PLATFORM SHALL CONSIST OF COMPACTED ON-SITE SOIL. PLATFORM SHALL BE 1.5X THE WIDTH OF THE ROOTBALL AND INCLUDE 45-DEGREE SIDE SLOPES (MAX.).
6. INSTALL FILTER FABRIC BETWEEN TREE PLATFORM AND NO.57 STONE/ROCK MULCH.
7. TREE PLATFORMS TO BE PLACED TREE LOCATIONS. REFER TO LANDSCAPE PLAN.

DETAIL NO. LID-07	STANDARD DETAIL ENGLISH	BIORETENTION SYSTEMS	REVISED 01-29-2019	DETAIL NO. LID-07
-----------------------------	------------------------------------	-----------------------------	-----------------------	-----------------------------

6. BIORETENTION SYSTEMS

Bioretention is a treatment process that removes pollutants from stormwater through an engineered soil media. Bioretention systems (LID-07) may either allow percolation into the subsoil or may have an underdrain that directs infiltrated stormwater to a downstream drainage system. These differ from stormwater harvesting basins and rain gardens because they are generally deeper and their main purpose is to capture pollutants and to provide a medium to infiltrate stormwater. Like stormwater harvesting basins, bioretention systems can be constructed within roadway ROWs or areas of limited ROW.

6.1 APPLICABILITY AND ADVANTAGES

Bioretention systems are applicable to residential, commercial, and industrial sites and along roadways where stormwater volume reduction by infiltration or improved water quality is desired. Bioretention may be particularly well-suited to urban locations with highly impervious sites where space is limited, because they can provide higher infiltration rates.

- This facility is an active water purification system, thereby improving water quality.
- The increased open space of a bioretention area can be multifunctional, providing wildlife habitat and creating a “softer” aesthetic for streets and roads by incorporating additional landscaping and vegetation.
- Bioretention creates planting conditions that encourage enhanced vegetation growth that can help cool adjacent land areas and reduce the Phoenix Metropolitan Area heat island phenomenon.
- Bioretention can reduce the reliance on potable

water sources for landscaping irrigation for other portions of the project area, depending on the landscape design and the volume and pattern of stormwater collection.

- Bioretention provides a drainage option from traditional drainage approaches, particularly for space-constrained, highly urbanized environments.
- Bioretention reduces vector concerns due to limiting ponding.

6.2 DESIGN CONSIDERATIONS

- Bioretention systems are relatively simple to build and relatively easy to maintain.
- If the side slopes where the inflow will occur are steeper than 3 to 1, they should be rock-lined.
- Bioretention areas should have a sediment trap at the inlet to collect the concentrated flow to prevent clogging, thereby prolonging the effective lifespan of the facility.
- If underdrains are used, they should be a minimum of 6 inches in diameter so that they can be cleaned without being damaged. A vertical clean-out pipe is an optional item. PVC and HDPE pipes used as underdrains should conform to ASTM D3034 and AASTHO 252M, respectively.
- The underdrain should be placed parallel to the bottom of the bioretention collector and backfilled and bedded with 6 inches of washed ASTM No. 57 or approved equal aggregate drain rock, which should encase at least 1 foot around the sides and top of the underdrain.
- Subterranean outlets associated with the underdrain must connect to an appropriate downstream drainage facility, LID element,

- and/or underground stormwater collection system.
- The BSM should be minimum of 36 – 42 inches, depending on the design to accommodate a 48-inch box tree planting. The recommended depth for a bioretention system in a desert environment to remove pollutants was developed in the Pima County Low Impact Development and Green Infrastructure Guidance Manual (Reference 1) and is shown in Table 4.
- The runoff volume can be calculated from first flush design storm (0.5 inch) based on the drainage area. The recommended ponding depth for a bioretention system should be 9 – 12 inches, with 3 inches of freeboard from an overflow structure to the berm or the lowest adjacent finished grade surrounding the system. The system should drain ponded water within 36 hours to prevent any vector-control issues. The underground runoff should drain within 72 hours so that the facility remains effective during the monsoon. An overflow structure or dedicated outlet should be included with the design so that larger storms have an outfall.
- The bioretention system should be sized using the first flush design storm (0.5 inch) volume V_{design} , with the limiting infiltration rate k (inches/hour); depth of soil medium d (feet); the porosity of the soil medium n ; the allowable ponding depth p (feet); and whether the bioretention system has an underdrain. The minimum required area for the bioretention system with an underdrain can be calculated using this equation from the Pima County LID Manual (See Reference 1):

$$A = \frac{V_{design}}{(d_s + n_s) + (d_g + n_g) + p + d_{in}}$$

Table 4. Recommended Depth of Bioretention Media to Target Pollutant of Concern

Pollutant of Concern	Removal Zone	Recommended Depth (feet)
Sediment	Surface, top to 2 to 8 inches	1.5
Total Nitrogen	At depth in saturated layer (>2 feet)	3
Total Phosphorus	Top 1 to 2 feet	2
Pathogens	Top 1 to 2 feet	2
Metals	Top 1 to 2 feet	2
Oil and grease	Surface	2
Temperature	At depth	4

- Watering is typically accomplished through an underground irrigation system whose volume may be reduced over time and/or abandoned once the plants have been established, depending on the success of the landscape installation and the volume and pattern of stormwater collection.

6.3 CONSTRUCTION CONSIDERATIONS

- The construction area should be fenced off with construction fencing or silt fencing to prevent compaction of soils by construction equipment or traffic during construction of surrounding improvements.
- At a minimum, the subgrade soils should have the top 6 – 8 inches scarified. A percolation test should be completed before the construction of the underground storage area to determine if the site soils will perform as anticipated and/or if an underdrain is necessary.
- After excavation of existing soils, inspections should be performed to ensure that the bioretention system meets the design specifications. Filter fabric should not be placed over the scarified subgrade. If an underdrain pipe is used, it should be surrounded by ASTM No. 57 (or approved equal) washed gravel.
- Rock must be washed and free of fine particles before being placed in the bioretention system.
- Once the prepared soil has been placed, limit compaction of the prepared soil to the specified requirements.

where

V_{design} = design stormwater volume (cubic feet)

K = effective infiltration rate (inches/hour)

d_s = depth of the soil medium (feet)

n_s = porosity of the soil medium (dimensionless)

d_g = depth of the rock, stone or gravel layer (feet)

n_g = porosity of the rock, stone, or gravel layer (dimensionless)

p = allowable ponding depth (feet)

d_{in} = depth of infiltration calculated as

$$d_{in} = k \left(\frac{p + d_g}{d_g} \right) \cdot (3hrs) \cdot (1ft/12in)$$

where

k = effective infiltration rate of the subsoil (inches/hour)

$3 hrs$ = assumed storm duration and approximate time of runoff

- Bioretention systems are typically landscaped. The design objective is typically to improve the aesthetics of the bioretention area and/or to install plant materials that will thrive in BSM and within the inundation characteristics of the element. Soil-building materials such as organic mulch, biota, and fertilizers may be incorporated into the prepared soil to improve vegetative success; the need for these can be identified through soil fertility testing and by specifically defining the landscaping objectives and performance expectations. In the Sonoran Desert, the landscaping treatment will usually be limited to a select list of plants (Refer to Section 3). Irrespective of these plants' ability to thrive in an artificial environment, they will require some degree of supplemental watering to get the plants established and periodically during dry periods to maintain their viability.

6.4 MAINTENANCE

This LID feature should be inspected quarterly and after storms of 0.5 inches or greater. Any significant sediment accumulation or debris should be cleared. The cleanout risers should be opened and visually inspected during routine maintenance. Any ponded water should be documented. Section 3 identifies the maintenance practices for the landscape element of this LID treatment. If an altered water flow pattern, erosion, or plant die-off is observed, these should be corrected in kind, at a minimum, and/or evaluated for further corrective measures.

6.5 COMPATIBILITY WITH OTHER LID PRACTICES

A sediment trap and curb opening are often designed in conjunction with this element. When an underdrain system is necessary, an appropriate outlet must be found.

6.6 SPECIFICATIONS

SECTION 645 - BIORETENTION SYSTEM

645.1 DESCRIPTION

Work under this item includes the construction of a bioretention system and associated appurtenances. Except as herein stated, the requirements specified for MAG Specifications 201, 206, 215, 220, 425, and 796 are applicable to this specification.

A bioretention system may include tree, shrub and groundcover plantings, see Section 3. Possible areas for bioretention include tree space, parking lanes, bump-outs for traffic calming, intersection triangles, open areas, and areas adjacent to sidewalk.

645.2 MATERIALS

See MAG Specifications 201, 215, 220, 425, 430, and 796.

A reservoir layer of 4 – 6 inches of open graded ASTM No. 57 stone shall be placed beneath the bioretention layer and geotextile shall be placed between the stone and the BSM.

645.3 GENERAL

Bioretention systems prepared soil should be a minimum of 36 – 42 inches to accommodate the planting of 48-inch box trees.

Edge conditions around bioretention facilities adjacent to pedestrian areas may be sloped to 3 to 1 maximum. Bioretention with a sloped side must provide a (8 percent maximum slope) 2-foot minimum width buffer of different material to meet flush with adjacent sidewalk. Bioretention with a depth greater than 3 feet must provide a (8 percent maximum slope) 24-inch minimum width buffer.

Access is required to all bioretention areas for maintenance. For facilities off the road, an access road may be needed. For facilities on high speed roads, ensure safe access via a shoulder or designated area. Within the bioretention area, the overflow structure must be accessible to maintenance crews.

645.3.1 Temporary Erosion Control

Install all temporary erosion control measures prior to site disturbance. Inspect erosion control measures at least once a week and after each rainfall event. Make any required repairs immediately. Erosion control devices shall be maintained until the site is stabilized, as determined by the Engineer.

645.3.2 Construction Sequence Scheduling

An implementation schedule should be included as part of the erosion control plan to identify the order of operations for construction activities. This is particularly important when constructing features designed to infiltrate stormwater runoff. There are many construction activities which may contribute to the failure of a stormwater BMP if they are not planned for accordingly. The following items should be considered in developing an implementation schedule for a project:

- A. Perform continuous inspection of temporary construction access to ensure that it is providing adequate erosion and sedimentation control for the construction site.
- B. Install erosion protection along the perimeter of the site to prevent sediment from leaving the site during the construction process. Protection should be installed at a uniform elevation and constructed so that flow cannot bypass the ends.
- C. All down-gradient perimeter sediment-control BMPs (e.g. temporary outlet controls) must be in place before any up-gradient land-disturbing activity begins.
- D. Install underground utilities (water, sanitary sewer, electric, telephone, etc.) taking the location and function of stormwater BMPs into consideration.
- E. Rough grade the site leaving the basin area undisturbed until the contributing drainage area has been completed and the site is stabilized.
- F. Perform all other site improvements in a manner that minimizes adverse impacts to the location and function of the stormwater BMPs.
- G. Final grade the site. Grading of the basin shall be accomplished using low-impact earth-moving equipment to prevent compaction of

10 LID TECHNICAL STANDARD DETAILS AND SPECIFICATIONS

the underlying soils. Wide-tracked vehicles such as backhoes, small dozers and skid-steers are recommended. Excavating equipment should operate from the side of the basin to the extent feasible.

- H. At a minimum, the subgrade shall be scarified, ripped, or tilled to a depth of 6 – 8 inches with equipment having tines spaced no greater than 8 – 12 inches apart. A minimum of two percolation tests should be completed for every 40,00 square feet of the excavated area before placing the rock to determine if the site soils will perform as designed. Alterations to the work, such as additional modifications to the subgrade soils or the installation of an underdrain shall be measured and paid for in accordance with Section 104 of the Standard Specifications.
- I. Stabilize the site by implementing the landscaping plan.
- J. Install any required erosion control blanket, ditch checks, and other semi-permanent and permanent erosion control measures.
- K. Remove the temporary erosion and sediment controls after the basin is stabilized per the Engineer's approval. It is important for the basin to be stabilized before receiving stormwater flow.

645.4 MEASUREMENT AND PAYMENT

The unit of measure for a bioretention system will be cubic yards. The payment will be in accordance with the following MAG Specification Sections, including all labor, materials, tools, and equipment needed to complete work specified.

- Section 201 – Clearing and Grubbing
- Section 215 – Earthwork for Open Channels
- Section 220 – Riprap Construction
- Section 430 – Landscaping and Planting
- Section 796 – Geosynthetics

THIS PAGE LEFT INTENTIONALLY BLANK

10 LID TECHNICAL STANDARD DETAILS AND SPECIFICATIONS

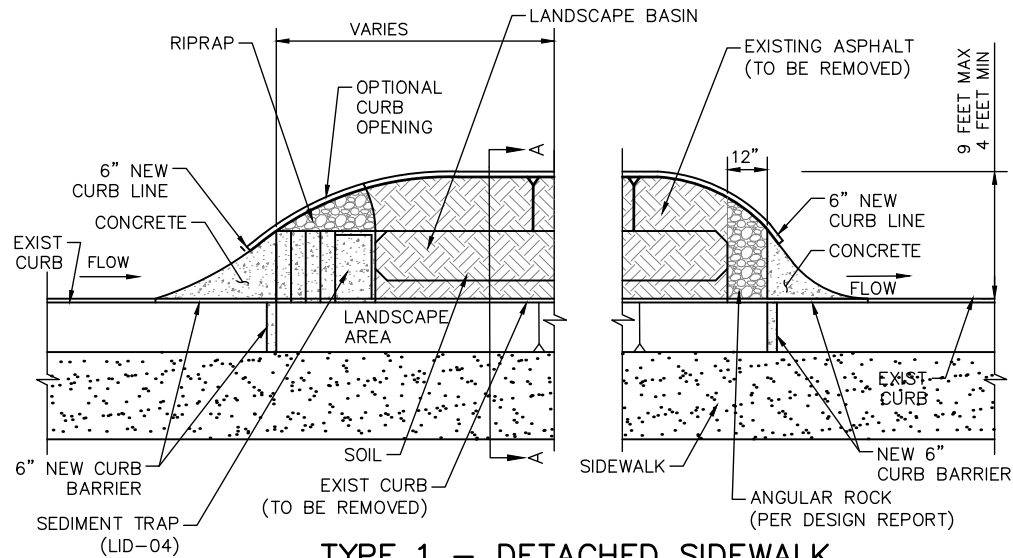

TYPE 1 – DETACHED SIDEWALK

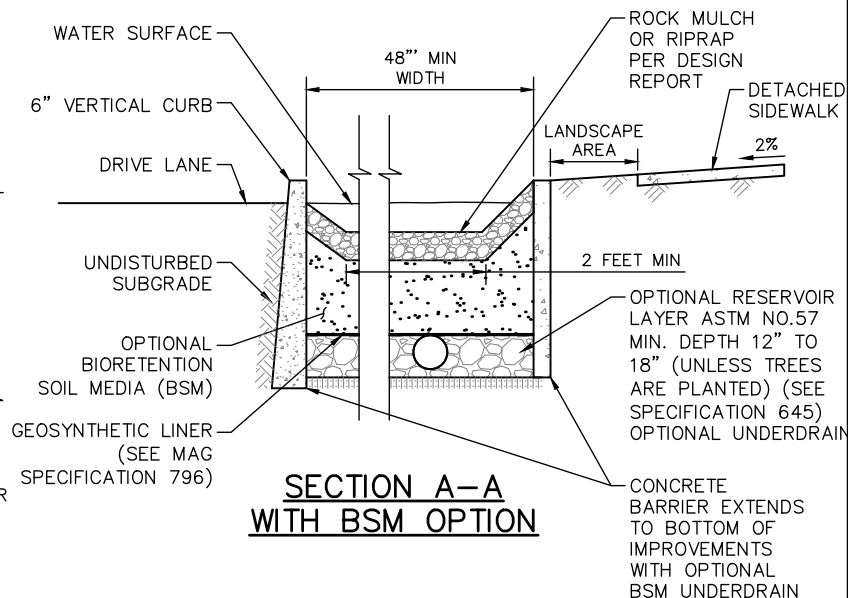

**SECTION A-A
WITH BSM OPTION**

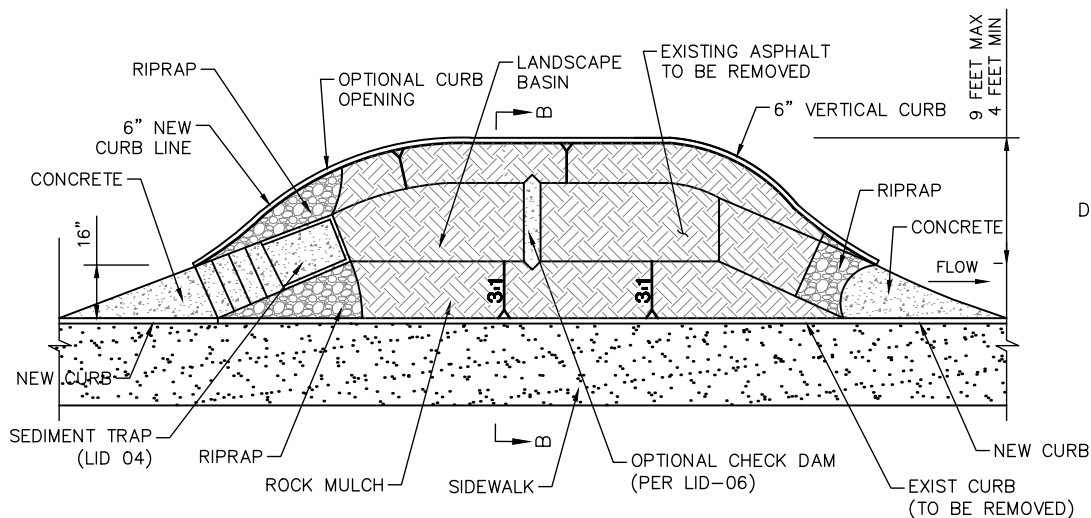

TYPE 2 – SIDEWALK ATTACHED TO CURB

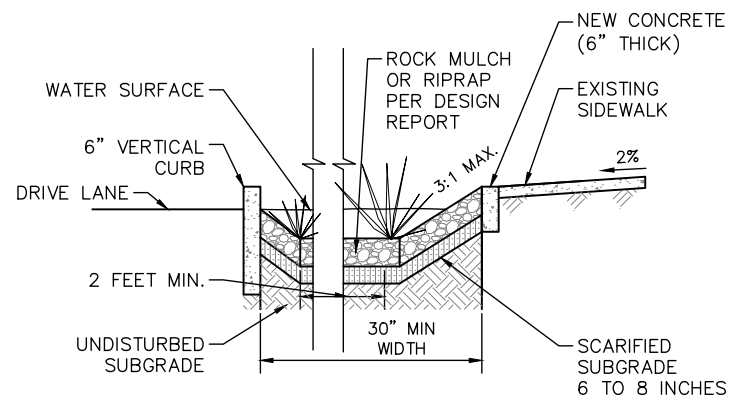

**SECTION B-B
W/O BSM**

DETAIL NO. LID-08	STANDARD DETAIL ENGLISH	CURB EXTENSIONS	REVISED 01-29-2019	DETAIL NO. LID-08
-----------------------------	------------------------------------	------------------------	-----------------------	-----------------------------

7. CURB EXTENSIONS

Curb extensions (LID-8) are generally placed in locations where a new curb is built out into a travel or parking lane to create an opportunity for the bioretention of street runoff and a space for trees. Curb extensions (also known as chicanes) may have sloped or vertical sides. In most cases, curb extensions will be designed as online (flow-through) elements. Curb extensions are typically landscaped.

7.1 APPLICABILITY AND ADVANTAGES

This LID element can be used along low-speed roadways, driveways, and parking lots.

- This LID element can also function well in urban streetscapes as a traffic-calming measure.
- Curb extensions are easy to retrofit into an existing area.
- The increased open space of the curb extension can create a “softer” aesthetic for streets and roads by incorporating additional landscaping and vegetation.
- The curb extension landscaping creates planting conditions that encourage enhanced vegetation growth that helps cool adjacent land areas and reduce the Phoenix Metropolitan Area heat island phenomenon.
- Curb extensions provide additional stormwater storage capacity as compared to conventional landscape planters.

7.2 DESIGN CONSIDERATIONS

- Minimum soil depth should be 12 – 18 inches to facilitate storage capacity and to be beneficial for vegetation. If trees are required, the landscape architect should recommend the minimum depth.
- The opening must be designed to collect the roadway flow width for the first flush design storm (0.5 inch) without causing ponding.
- Minimum planter width should be 30 inches, but any geometric shape can be built. The minimum width is dictated by the width of a small excavator or backhoe.
- Curb extensions should be designed carefully not to be in conflict with dry utilities.
- Curb extensions are typically designed with curb outlets allowing flow back onto the roadway so they act as a flow-through system.
- If used, underdrains must be connected to a downstream conveyance facility or additional LID element with a positive outlet for extra drainage.
- Curb extensions are typically landscaped. The design objective is typically to improve the aesthetics of the streetscape, to provide shade and landscaping for comfort, and/or to install plant materials that will thrive in the BSM and within the inundation characteristics of the element. Soil-building materials such as organic mulch, biota, and fertilizers may be incorporated into the BSM to improve vegetative success; the need for these can be identified through soil fertility testing and by specifically defining the landscaping objectives and performance expectations. In the Sonoran Desert, the landscaping treatment will usually be limited to a select list of plants (refer to Section 3). Irrespective of these plants’ ability to thrive in

an artificial environment, they will require some degree of supplemental watering to get the plants established and periodically during dry periods to maintain their viability. Watering is typically accomplished through an underground irrigation system whose volume may be reduced over time and/or abandoned once the plants have been established, depending on the success of the landscape installation and the volume and pattern of stormwater collection.

7.3 CONSTRUCTION CONSIDERATIONS

The asphalt, concrete curb, and subgrade removal are construction considerations and they should adhere to the MAG Specification (Reference 16). The construction areas should be fenced off with a construction fence or silt fence to prevent soil compaction from equipment during construction of surrounding improvements. After excavation of existing soils, inspections and a percolation test should be completed before the construction of the underground storage area to determine if the site soils will meet the design criteria and/or if an underdrain is necessary. At a minimum, the bottom of the curb extension planter should have the top 6 – 8 inches scarified. Shoring may be required to reduce the potential of the adjacent soils from sloughing into the construction area.

If an underdrain pipe is used, it should be surrounded by ASTM No. 57 (or approved equal) washed gravel and geotextile fabric. Gravel must be washed and free of fine particles before being placed in the bioretention planter. Once the

10 LID TECHNICAL STANDARD DETAILS AND SPECIFICATIONS

gravel drainage layer and prepared soil have been placed, limit compaction of the prepared soil to the specified requirements. The structural properties of the soil must be considered during excavation.

7.4 MAINTENANCE

This LID element should be inspected quarterly and after storms of 0.5 inch or greater. These inspections are needed because damage is not apparent during dry weather. Any significant sediment accumulation or debris should be cleared. Any ponded water should be documented. Section 3 identifies the maintenance practices for the landscape element of this LID treatment. If an altered water flow pattern, erosion, or plant die-off is observed, these should be corrected in kind, at a minimum, and/or evaluated for further corrective measures.

7.5 COMPATIBILITY WITH OTHER LID PRACTICES

Curb extensions are compatible with curb openings, sediment traps, permeable pavements, and overflow structures.

7.6 SPECIFICATIONS

SECTION 647 – CURB EXTENSION

647.1 DESCRIPTION

Work under this item includes the construction of a curb extension and associated appurtenances. Except as herein stated, the requirements specified for MAG Specifications 201, 205, 206, 215, 220, 320, 350, 401, 425, 430, and 796 are applicable to this specification.

A curb extension is typically a small-scale bioretention cell located along rural streets between and replaces the roadway and roadway curb. These facilities may include tree, shrub, and groundcover plantings.

647.2 MATERIALS

See MAG Specifications 201, 215, 220, 425, 430, and 796.

A reservoir layer of 12 – 18 inches of open graded ASTM No. 57 stone shall be placed beneath the prepared soil. Geotextile shall be placed on the sides of the stone.

647.3 GENERAL

Curb extension systems are designed to have an upstream and downstream curb opening that allows runoff to flow through a passive filtration system.

When placing and designing curb extension facilities adjacent to travel ways, check the AASHTO Roadway Design Guidebook for approach distances, curb height, and curb radius dimensions. This feature is constructed adjacent to travel lanes and should follow MAG Specification 401 for traffic control.

Access is required to all bioretention areas for maintenance. For facilities on high-speed roads, ensure a safe access route for maintenance personnel.

647.3.1 Temporary Erosion Control

An access road may be needed. Install temporary erosion control measures prior to site disturbance. Inspect erosion control measures once a week and after each rainfall event. Make any required repairs immediately. Erosion control devices shall be maintained until the site is stabilized, as determined by the Engineer.

647.3.2 Construction Sequence Scheduling

An implementation schedule should be included as part of the erosion control plan to identify the order of operations for construction activities. This is particularly important when constructing features designed to infiltrate stormwater runoff. There are many construction activities which may contribute to the failure of a stormwater BMP if they are not planned for accordingly.

The following items should be considered in developing an implementation schedule for a project:

- A. Perform continuous inspection of temporary construction access to ensure that it is providing adequate erosion and sedimentation control for the construction site.
- B. Install erosion protection along the perimeter of the site to prevent sediment from leaving the site during the construction process. Protection should be installed at a uniform elevation and constructed so that flow cannot bypass the ends.
- C. Install underground utilities (water, sanitary sewer, electric, telephone, etc.) taking the location and function of stormwater BMPs into consideration.
- D. Perform all other site improvements in a manner that minimizes adverse impacts to the location and function of the stormwater BMPs.
- E. Final grade the site. Grading of the curb

extension shall be accomplished using low-impact earth-moving equipment to prevent compaction of the underlying soils. Wide-tracked vehicles such as backhoes, small dozers, and skid-steers are recommended. Excavating equipment should operate from the side of the basin to the extent feasible.

- F. At a minimum, the subgrade shall be scarified, ripped, or tilled to a depth of 6 – 8 inches with equipment having tines spaced no greater than 8 – 12 inches apart. A minimum of one percolation test should be completed for each curb extension planting area unless the Engineer approves fewer tests based on the facility size and adjacent planters. Alterations to the work, such as additional modifications to the subgrade soils or the installation of an underdrain shall be measured and paid for in accordance with Section 104 of the Standard Specifications.
- G. Stabilize the site by implementing the landscaping plan.
- H. Install any required erosion control blanket, ditch checks, and other semi-permanent and permanent erosion control measures.
- I. Remove the temporary erosion and sediment controls after the basin is stabilized per the Engineer's approval. It is important for the basin to be stabilized before receiving stormwater flow.

647.4 MEASUREMENT AND PAYMENT

The unit of measure for a curb extension will be cubic feet. The payment will be in accordance with the following MAG Specification Sections, including all labor, materials, tools, equipment and incidentals needed to complete work specified.

- Section 201 – Clearing and Grubbing
- Section 215 – Earthwork for Open Channels
- Section 220 – Riprap Construction
- Section 430 – Landscaping and Planting
- Section 796 – Geosynthetics

10 LID TECHNICAL STANDARD DETAILS AND SPECIFICATIONS

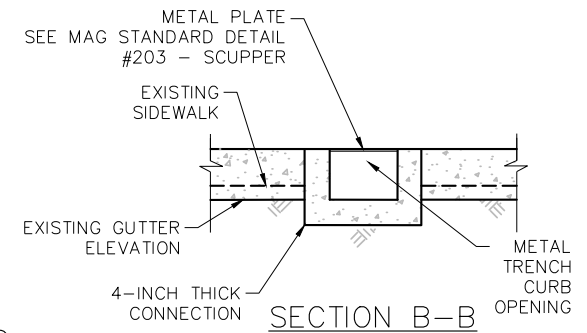
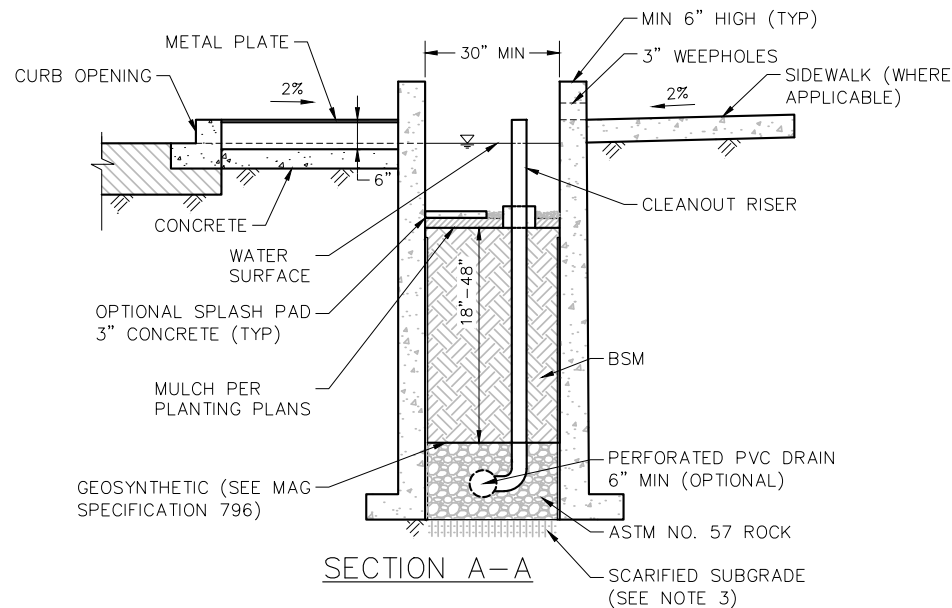
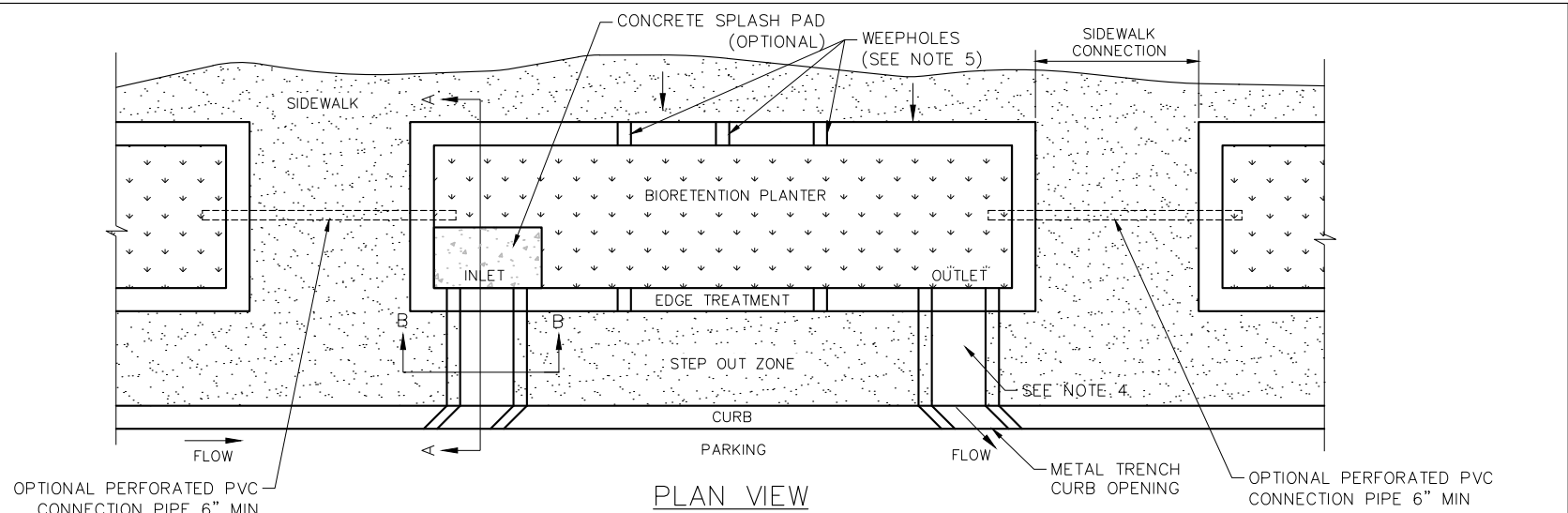

NOTES:

1. MIN. WIDTH IS 30 INCHES.
2. MIN. LENGTH IS 5 FEET.
3. SCARIFY SUBGRADE 4"-6" MIN. BEFORE INSTALLATION.
4. OUTLET SHOULD BE SLIGHTLY LOWER THAN INLET.
5. 3-INCH WEEP HOLES GRADED TOWARD PLANTER.

DETAIL NO.
LID-09

**STANDARD DETAIL
ENGLISH**

BIORETENTION PLANTERS

REVISED
01-29-2019

DETAIL NO.
LID-09

8. BIORETENTION PLANTERS

Bioretention planters (LID-09) are typically a small-scale bioretention cell, often located in hardscape areas between the curb and sidewalk. These elements may include tree, shrub, and groundcover plantings. This LID feature may be designed at depths that require railings or curbs for pedestrian safety.

8.1 APPLICABILITY AND ADVANTAGES

This LID application can be used where there is available ROW and an offset from travel lanes. Curb openings can be designed in conjunction with this LID feature.

- Bioretention planters function well in urban streetscape designs.
- Bioretention planters provide additional stormwater storage capacity as compared to conventional landscape planters.
- Bioretention planters work in urban settings with MAG Concrete Scupper 206, 1 – 3.
- Bioretention planters create planting conditions that encourage enhanced vegetation growth that helps cool adjacent land areas and reduce the Phoenix Metropolitan Area heat island phenomenon.

8.2 DESIGN CONSIDERATIONS

- Minimum soil depth should be 18 inches to facilitate storage capacity and to provide a benefit for vegetation. Trees and deep-rooted vegetation would require 36- to 42-inch minimum soil depth as determined by a landscape architect.

- The minimum planter width should be 30 inches so they are easy to construct with a small excavator or backhoe, but any geometric shape can be built.
- Curbed openings and piped entrances, such as roof downspouts, should include rock, splash blocks, or other erosion controls at the ground line of the bioretention planter to dissipate energy and disperse flows.
- The basin areas should be sized to capture and treat the first flush design storm (0.5 inch) and drain surface water in less than 36 hours. The subsurface would need to infiltrate the runoff within 72 hours. The time for the selected ponding depth to filter through the media can be calculated using an equation from the Los Angeles LID Manual (Reference 17):

$$t_p = \frac{d}{\left(\frac{f_{design}}{12}\right)}$$

where:

t_p = required detention time for surface ponding (max 36 hours) (hr)

d = ponding depth (maximum 3 feet) (ft)

f_{design} = design infiltration rate (in/hr)

- If t_p exceeds 36 hours, reduce surface ponding depth (d). In nearly all cases, t_p should not approach 36 hours unless f_{design} is low (< 0.3 inches per hour).

- The area of bioretention planter can be calculated using the following equation, the volume required is determined by the first flush design storm:

$$A = \frac{V_B}{d}$$

Where:

A = bottom surface area of bioretention planter area (ft²)

V_B = bioretention planter design volume (ft³) and

d = ponding depth (maximum 1 foot) (ft).

- The underdrain shall have a mainline diameter of 6 inches using slotted PVC SDR 26 or PVC C9000. Slotted PVC allows for pressure water cleaning and root cutting, if necessary. The slotted pipe should have 2 – 4 rows of slots cut perpendicular to the axis of the pipe or at right angles to the pitch of corrugations. Slots should be 0.04- to 0.1-inch wide and 1 – 1.25 inches long. Slots should be longitudinally spaced such that the pipe has a minimum of a 1 square inch opening per linear foot and should face downward.
- The underdrain pipe should be wrapped in geotextile.
- Underdrains should be sloped at a minimum of 0.5 percent for positive drainage. The underdrain must flow freely to an acceptable discharge point.
- The underdrain should be elevated from the bottom of the stormwater planter by 6 inches. The gravel envelope should be ASTM No. 57 (or approved equal) washed gravel. The top and sides of the underdrain pipe should be covered with gravel to a minimum depth of 6 inches.

10 LID TECHNICAL STANDARD DETAILS AND SPECIFICATIONS

- Geotextile fabric should be used to separate the prepared soil and the gravel envelope.

Bioretention planters are typically landscaped. The design objective is typically to improve the aesthetics of the planter, to provide shade and landscaping for comfort, and/or to install plant materials that will thrive in the prepared soil and within the inundation characteristics of the element. Soil-building materials such as organic mulch, biota, and fertilizers may be incorporated into the prepared soil to improve vegetative success; the need for these can be identified through soil fertility testing and by specifically defining the landscaping objectives and performance expectations. In the Sonoran Desert, the landscaping treatment will usually be limited to a select list of plants (Refer to Section 3). Irrespective of these plants' ability to thrive in an artificial environment, they will require some degree of supplemental watering to get the plants established and periodically during dry periods to maintain their viability. Watering is typically accomplished through an underground irrigation system whose volume may be reduced over time and/or abandoned once the plants have been established, depending on the success of the landscape installation and the volume and pattern of stormwater collection.

8.3 CONSTRUCTION CONSIDERATIONS

Construction areas should be fenced off with a construction fence or silt fence to prevent soil compaction from equipment during construction of surrounding improvements. After excavation of existing soils, inspections and a percolation test should be completed before the construction of the underground storage area to determine if the

site soils will meet the design criteria and/or if an underdrain is necessary. At a minimum, the bottom of the bioretention planter should have the top 6 – 8 inches scarified. Shoring may be required to reduce the potential of the adjacent soils from sloughing into the construction area.

If an underdrain pipe is used, it should be surrounded by ASTM No. 57 (or approved equal) washed gravel and geotextile fabric. Gravel must be washed and free of fine particles before being placed in the bioretention planter. Once the gravel drainage layer and prepared soil have been placed, limit compaction of the prepared soil to the specified requirements.

8.4 MAINTENANCE

This LID element should be inspected quarterly and after storms of 0.5 inches or greater. Any significant sediment accumulation or debris should be cleared. The cleanout risers should be opened and visually inspected during the routine maintenance. Any ponded water should be documented. Section 3 identifies the maintenance practices for the landscape element of this LID treatment. If an altered water flow pattern, erosion, or plant die-off is observed, these should be corrected in kind, at a minimum, and/or evaluated for further corrective measures.

8.5 COMPATIBILITY WITH OTHER LID PRACTICES

Bioretention planters can be integrated with curb openings.

8.6 SPECIFICATIONS

SECTION 646 - BIORETENTION PLANTER

646.1 DESCRIPTION

Work under this item includes the construction of a bioretention planter and associated appurtenances. Except as herein stated, the requirements specified for MAG Specifications 201, 206, 215, 220, 425, 430, and 796 are applicable to this specification.

A bioretention planter is typically a small-scale bioretention cell, often located between the curb and sidewalk. These facilities may include tree, shrub and groundcover plantings, see Specification 430. Streetscape bioretention planters will usually have vertical sides but may have sloped sides if sufficient space is available.

646.2 MATERIALS

See MAG Specifications 201, 215, 220, 425, 430, and 796.

A geotextile layer shall be placed beneath the bioretention soil to prevent the soil from migrating into the underlying stone. A reservoir layer of 18 inches of open graded ASTM No. 57 stone shall be placed beneath the geotextile layer, with perforated pipes embedded in the ASTM No. 57 stone. Geotextile shall be placed on the sides of the stone.

Underdrains are to be constructed following Specification 622. Connect underdrains to catch basins, manholes, or direct connect to storm drain pipe, with applicable permitting. Connection to catch basin is generally the most cost-effective option.

646.3 GENERAL

Overflow devices are recommended where the lowest adjacent top of curb or sidewalk is equal to or lower than the inflow point elevation. Typical overflow devices include outflow curb openings to gutter, and overflow structures.

Bioretention facility edges that are adjacent to pedestrian areas may be sloped or with a vertical drop. Railings are required around bioretention with a vertical drop adjacent to sidewalks in high-volume pedestrian areas and follow MAG Specification 415. The top of railing shall be 42 inches above the sidewalk, with vertical and/or horizontal member spacing that meets ADA detection requirements for visually impaired pedestrians. Bioretention with a vertical drop adjacent to sidewalks in low-volume pedestrian areas must be surrounded by a curb of minimum 6 inches high and 6 inches wide. Bioretention with a vertical drop must have a minimum 6-inch high curb or 42-inch railing between the parking step out zone and the drop. Bioretention with a sloped side must provide a flat (8 percent maximum slope) 6-inch minimum width buffer of different material to meet flush with adjacent sidewalk. Bioretention with a depth greater than 3 feet must provide a flat (8 percent maximum slope) 24-inch minimum width buffer.

Bioretention facilities with sloped sides with a total depth of more than 5 feet shall require a fence of 42-inch height enclosing the entire facility. Facilities with a greater than 30-inch vertical drop require a 42-inch railing meeting MAG Specification 415.

Access is required to access all bioretention areas for maintenance. Provide a safe, practical access route for maintenance crews.

646.3.1 Temporary Erosion Control

Install all temporary erosion control measures prior to site disturbance. Install storm drain inlet protection to prevent clogging of the storm drains and increases in sediment loads to downstream stormwater facilities or waterbodies. Inspect erosion control measures at least once a week and after each rainfall event. Make any required repairs immediately.

Erosion control devices shall be maintained until the site is stabilized, as determined by the Engineer.

646.3.2 Construction Sequence Scheduling

An implementation schedule should be included as part of the erosion control plan to identify the order of operations for construction activities. This is particularly important when constructing stormwater GI Infrastructure that is designed to infiltrate stormwater runoff. There are many construction activities which may contribute to the failure of a stormwater BMP if they are not planned for accordingly. The following items should be considered in developing an implementation schedule for a project:

- A. Perform continuous inspection of temporary construction access to ensure that it is providing adequate erosion and sedimentation control for the construction site.
- B. Install erosion protection along the perimeter of the site to prevent sediment from leaving the site during the construction process. Protection should be installed at a uniform elevation and constructed so that flow cannot bypass the ends.
- C. All down-gradient perimeter sediment-control BMPs (e.g. temporary outlet controls) must be in place before any up-gradient land-disturbing activity begins.
- D. Install underground utilities (water, sanitary sewer, electric, telephone, etc.) taking the location and function of stormwater BMPs into consideration.
- E. Rough-grade the site leaving the basin area undisturbed until the contributing drainage area has been completed and the site is stabilized.
- F. Perform all other site improvements in a manner that minimizes adverse impacts to the location and function of the stormwater BMPs.
- G. Final grade the site. Grading of the basin shall be accomplished using low-impact earth-moving equipment to prevent compaction of the underlying soils. Wide-tracked vehicles such as backhoes, small dozers, and skid-steers are recommended.
- H. At a minimum, the subgrade shall be scarified, ripped, or tilled to a depth of 6 – 8 inches with equipment having tines spaced no greater than 8 – 12 inches apart. A minimum of one percolation test should be completed for each bioretention planter unless the Engineer approves fewer tests based on the bioretention size and adjacent planters. Alterations to the work, such as additional modifications to the subgrade soils or the installation of an underdrain shall be measured and paid for in accordance with Section 104 of the Standard Specifications.
- I. Stabilize the site by implementing the landscaping plan.
- J. Install any required erosion control blanket, ditch checks, and other semi-permanent and permanent erosion control measures.
- K. Remove the temporary erosion and sediment controls after the planter is stabilized per the Engineer's approval. It is important for the planter to be stabilized before receiving stormwater flow.

10 LID TECHNICAL STANDARD DETAILS AND SPECIFICATIONS

646.4 MEASUREMENT AND PAYMENT

The unit of measure for the bioretention planter will be per each and the payment will be made at the contract unit price per each specified. The payment will be in accordance with the following MAG Specification Sections, including all labor, materials, tools, equipment and incidentals needed to complete work specified.

- Section 201 – Clearing and Grubbing
- Section 215 – Earthwork for Open Channels
- Section 220 – Riprap Construction
- Section 430 – Landscaping and Planting
- Section 796 – Geosynthetics

THIS PAGE LEFT INTENTIONALLY BLANK

10 LID TECHNICAL STANDARD DETAILS AND SPECIFICATIONS

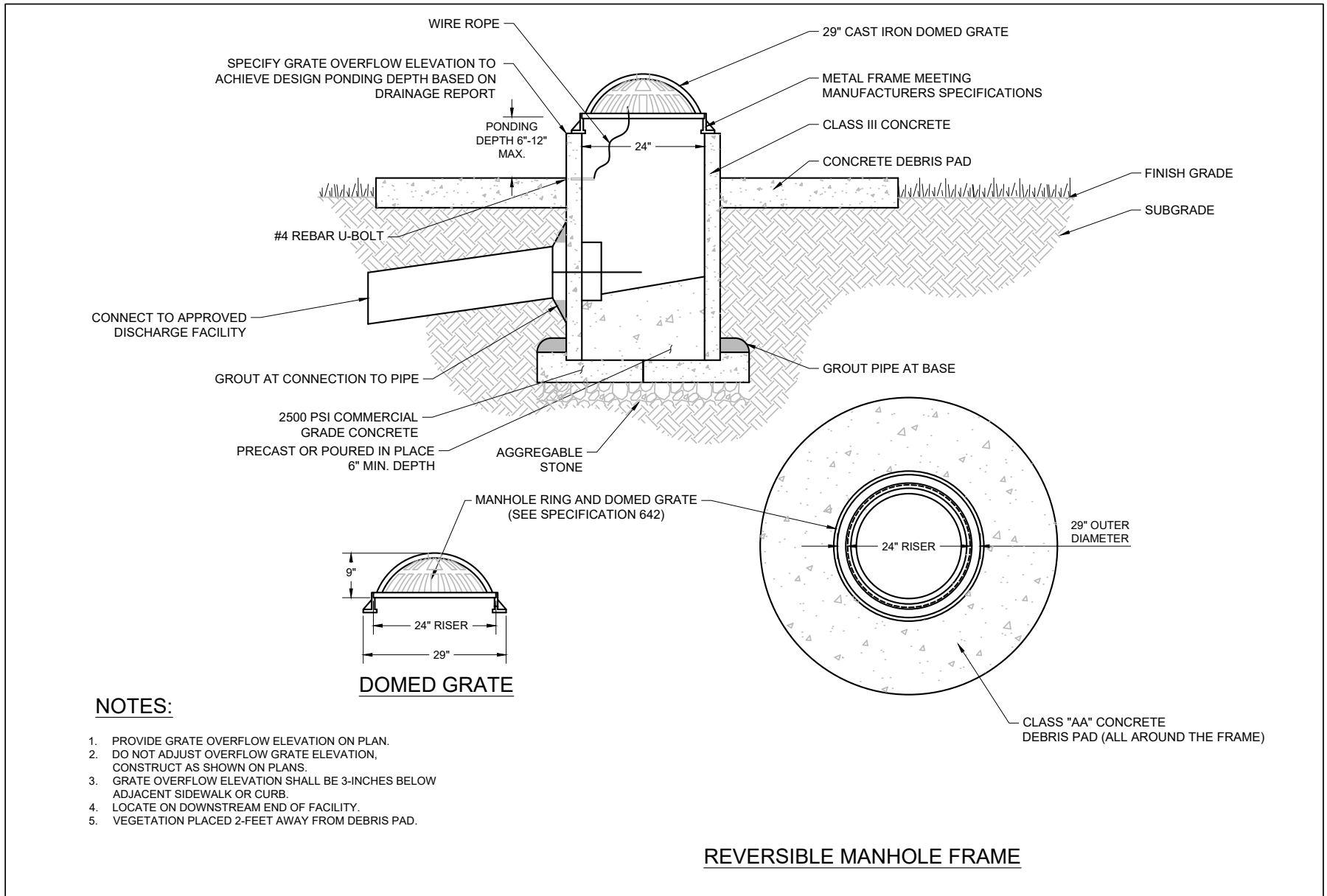

DETAIL NO. LID-10	STANDARD DETAIL ENGLISH	DOMED OVERFLOW STRUCTURES	REVISED 01-29-2019	DETAIL NO. LID-10
-----------------------------	------------------------------------	--------------------------------------	-----------------------	-----------------------------

9. DOMED OVERFLOW STRUCTURES

Overflow structures (LID-10) allow for ponding within multiple stormwater capture facilities and provide an outlet for larger storm events that exceed the capacity of each facility. Overflow structures drain into a downstream collection system, such as a storm drain, basin, channel, or natural wash.

9.1 APPLICABILITY AND ADVANTAGES

- Overflow structures are applicable to most commercial, industrial, and high-density residential developments that have a drainage collection system downstream. They are used in conjunction with other LID facilities or storage basins or are discharged to an appropriate receiving facility.
- A domed overflow structure has fewer maintenance issues compared to a flat grate placed in the bottom of a basin, because the ponded water allows sediments to drop out before entering the outlet opening. Similarly, debris must build up before it can enter the outlet.
- The debris pad surrounding the overflow structure provides easy removal of debris and sediment.

9.2 DESIGN CONSIDERATIONS

- Overflow structures must connect to a downstream collection system, such as a storm drain, basin, channel, or natural wash.
- The overflow structure must be designed to allow the overflow to drain without overtopping the overflow elevation. The grate overflow elevation should be at least 3 inches below adjacent sidewalk or top of curb.

- There should be a landscape buffer around the overflow structure so that vegetation does not interfere with element's ability to drain. There should be a 2-foot barrier from the debris pad to any vegetation.
- The inlet structure capacity can be designed with the orifice equation 3.14 presented in the FCDMC Hydraulic Manual (Reference 13) for the first flush (0.5 inches) design storm. The area of opening would need to be calculated accounting for the domed grate, the orifice equation is:

$$Q_i = C_0 h L (2g d_0)^{0.5}$$

Where

- Q_i = discharge (ft³/s)
- C_0 = orifice coefficient (0.67)
- g = gravity (32.2 ft²/s)
- d_0 = effective depth at the center of the curb opening orifice (ft)
- h = Curb opening catch basin height, curb opening orifice, or orifice throat (ft)
- L = length of curb opening (ft)

9.3 CONSTRUCTION CONSIDERATIONS

The grouting at the connection points should be carefully checked to ensure they are totally covered. The overflow structure should be located at the downstream end of a drainage facility. Connect riser to storm drain using the appropriate reducer fittings, tees, and/or elbows.

9.4 MAINTENANCE

Overflow structures should be inspected after storms of 1.25 inches or greater to make sure that they are not clogged with debris or sediments. Inspection should happen at least annually to remove any debris and prevent clogging of the inlet structure. Encroaching vegetation should be pruned or removed to maintain the landscape buffer.

9.5 COMPATIBILITY WITH OTHER LID PRACTICES

Overflow structures work well with other LID elements that involve surface water or ponding, such as vegetated or rock bioswales and stormwater harvesting basins, because they provide a specific outlet and mitigate the possibility the element will overtop.

9.6 SPECIFICATIONS

SECTION 642 - DOMED OVERFLOW STRUCTURE

642.1 DESCRIPTION

This work shall consist of furnishing and placing domed overflow risers in LID facilities as shown in the contract documents, or as directed by the Engineer. Except as herein stated, the requirements specified for MAG Specifications 324 and 505 are applicable to this specification.

10 LID TECHNICAL STANDARD DETAILS AND SPECIFICATIONS

642.2 MATERIALS

- Concrete Pipe Riser: PCC Pipe per MAG Specification 505.
- Concrete for Riser - Catch Basin – Concrete Debris Pad: PCC 2500 PSI per MAG Specification 505.
- Domed/Beehive Grate: 29-inch diameter domed grate using cast or ductile iron.

642.3 GENERAL

642.3.1 General Installation

Provide domed risers for LID facilities placed on aggregate stone as indicated in the design plans.

Top of riser shall be set as specified in the design plans for ponding depth and a minimum 3 inches below adjacent sidewalk or top of curb, as designed. Connect riser to underdrain piping using the appropriate glues, primers, fittings, tees, and/or elbows.

Landscaping should not interfere with their ability to drain. There should be a 2-foot barrier from the debris pad to any vegetation. They must be located at the downstream end of the feature.

642.3.2 Measure and Payment

The unit of measure for domed overflow risers will be per each. Payment for domed overflow risers will be made at the contract unit price per each for the diameter specified, which will include excavation, shoring, backfill, compaction, installation of pipe riser and stone base including connections, gaskets, domed/beehive grate, and all labor, materials, tools, equipment and incidentals needed to complete work specified.

SECTION 3 - LANDSCAPING DETAILS AND SPECIFICATIONS

The role of vegetation is obvious and inherent to the origination and success of LID treatments. While engineering analyses establish the stormwater management needs, the selection of appropriate LID treatments requires an integrated, iterative process between drainage and landscape designers based on on-site ecological resources, design requirements, and budgetary considerations. In Maricopa County, native vegetation is generally sparse, providing limited stormwater management functions. As a result, purposely installed landscaping is needed to produce an effective vegetative cover for LID treatments. To ensure viable landscaping, a number of factors must be considered. This section of the Handbook elaborates on those factors and offers guidance and recommendations on the design, implementation, and maintenance of LID landscaping.

GEOLOGIC SETTING

The Greater Phoenix Metropolitan Area is located within Arizona's Basin and Range Geological Province, which is characterized by numerous mountain ranges that rise abruptly from broad, plain-like valleys or basins (Reference 18). The mountains can range from 300 feet to several thousand feet above sea level. The mountain masses can extend for up to 60 miles in length and 15 miles in width. Over time and through mass wasting and granular disintegration, these protruding bedrock features have produced the basin fill material (soil) that is found in the intermountain basin areas around Phoenix and other parts of the State of

Arizona. Basin-area soils are made up of varying combinations and depths of gravels, sands, silts, clays, gypsum, salt, and other minerals found in the parent materials. Older basin fills exhibit profile development (layering) which is most notably exemplified in Arizona near the ground surface by caliche layers.

SOILS

"Soil" is the ubiquitous term used to describe the (non-rock) mineral materials that make up the earth's terrestrial crust. Ecologically, soil is important as the growing medium for the plants that cover and cool the earth's land areas. Soils and soil forming, as identified above, vary due to the effect of past and current actions such as mountain forming, mass wasting, volcanism, glaciation, and more subtle hydrologic, geochemical, and biological processes. Soils may be fine-grained or may consist of rocky, boulder-strewn matrices. Regardless of their texture or depth, soils overlay much deeper hard rock.

Soils have four main constituents: minerals, organic materials, air, and water. According to Hendricks, mineral matter makes up approximately 50 percent of Arizona soils, with air and water each comprising 25 percent, although McLane has indicated that in her soils testing laboratory, 15 percent water is more common (Reference 18; Reference 19). Organic matter comprises less than 5 percent in Arizona soils, with 1 percent being common (Reference 18; Reference 19).

Soils are typically referred to by their textures; the distinguishing characteristic is generally associated with the volume of sand, silt, or clay that the soils contain. These differences between soil types are determined by the size of their particles, with sand having the largest particles and clay having the smallest. Soils with roughly equal proportions of these separates are considered "loamy." A preferred soil for landscaping purposes is a loamy sand or sandy loam texture, which happens to be the primary soil makeup in Arizona and specifically in Maricopa County. Loamy sand and sandy loam are classified as coarse-textured soils; they contain a highly functional composition of mineral matter, air, and water that can be utilized by plants while also having a high level of hydraulic conductivity (permeability). Per McLane, Maricopa County soils typically percolate at a rate of 0.25 – 0.75 inches per hour and can possibly reach up to 2 inches per hour, depending on the location and site conditions (Reference 19).

When planning for LID techniques, other soil characteristics should be considered. High mineral counts affect the performance of site soils by limiting or prohibiting plant growth or causing plant death. Soils with high sodium (salt) content are not uncommon in Greater Phoenix; flushing agriculture crop areas with water is commonly required to keep salts from rising up in the soil layers and contacting the plant roots. Properly designed and maintained irrigation systems usually flush most salts from ornamental planting's root zones. Soil salinity, which is naturally caused by a combination of several select minerals (sodium, potassium, calcium,

LANDSCAPING DETAILS AND SPECIFICATIONS

magnesium, and chlorine) can also severely inhibit plant growth. Arizona soils are generally alkaline with a pH between 7 and 8.5; native plants are adapted to these conditions and the restrictions that alkaline soils create for nutrient uptake. However, many non-native plants struggle as the pH level rises.

It is not uncommon to find clay, caliche, or other hardpan soil layers at relatively shallow depths in Greater Phoenix. These conditions require perforating the impermeable layer or installing an underground drainage system so that supplemental irrigation or stormwater entering the planting area can be drained away, thereby reducing the risk of having plants sitting in saturated soil.

Because of the low organic content of Arizona soils, it is tempting to try to improve those conditions by introducing a higher amount of organic material into the growing medium. Organics, such as wood mulch; biosolids (manure); and hulls, however, should be carefully considered, since they have the potential of releasing concentrated minerals that can become toxic to plant life once the decomposition has occurred. This is because stubborn constituents will remain in the soil matrix until they are absorbed, flushed away, or converted over time through chemical reactions. For example, natural bark mulch, if not nitrogen-stabilized, will release nitrogen as it decomposes. Since the rate of decomposition is not controlled in the growing medium, nitrogen will be released at rates that may "burn" surrounding plants. Composted organics provide a level of protection from this occurrence. While there are concerns about the use of chemical fertilizers, they are more predictable than organic material when used to provide plantings with nutrients and micronutrients. Additionally, soils that are overloaded with organics could be subject to collapse over time.

Each of the above dynamics must be evaluated when considering whether to employ LID at a site. There are means for overcoming these conditions as long as the designer (and site manager) recognize the importance of making informed choices based on a detailed assessment of the site's soils, future maintenance needs, and ongoing monitoring.

PLANT PALETTE

Native plants have learned to survive in the harsh climate and soil conditions of the Sonoran Desert, and they define the landscape character of the southwestern United States (Reference 20). Native plants provide a variety of benefits beyond their appearance, including erosion protection, food sources, wildlife habitat, and human comfort (shade). However, landscape installations in the Greater Phoenix Metropolitan Area are not limited to native plants. Since the 1960s, horticulturalists and commercial nursery growers have been introducing arid-adapted plants from around the world into the Phoenix area. These introductions have significantly added to the landscape industry's plant palette, while also greatly enhancing the aesthetics and enjoyment of Arizona's outdoor places and living spaces.

Not all native and introduced species on the Greater Phoenix palette are permitted for use in public ROWs. In the early 1980s, the Arizona Department of Water Resources established planning areas correlated to Arizona's groundwater basins to provide regional perspectives on water supply and demand and management of statewide water resource issues. These Active Management Areas (AMAs) include most of the state's largest urbanized areas and provide a regulatory framework for addressing water resource issues. The Phoenix AMA compiled the Low Water Use

Drought Tolerant Plant List, which identifies the specific plant species permitted for use within public ROWs (for roads, streets, etc.). These plants have been evaluated by landscape and horticultural professionals and have been deemed compliant with the water-conserving objectives of the AMA. Landscape development on private land is not bound by the AMA restrictions or the Low Water Use List. As a result, a greater variety of plant species and LID techniques are available for use by these parties. The Arizona Municipal Water Users Association (www.amwua.org) and the Maricopa County Air Quality Department (www.cleanairmakemore.com) have published lists of viable plants in the Greater Phoenix Area using different selection criteria; these plants may be considered for use on LID installations when not on public ROWs. Some low water use plants are found on multiple lists.

Plants on the Low Water Use List have been chosen for their water conservation characteristics. It is understood that the low water use plants, much like all native and introduced species, can thrive under somewhat higher levels of periodic water contact. However, it is not known how much additional water and what watering intervals will, if at all, create detrimental conditions for these plants. You will note later in this document that plants have been identified based on their perceived ability to thrive above or below the anticipated inundation elevations (referred to as plants in groups A and B). Close monitoring of how native desert plants adapt to GI conditions will be important to determining the future success of LID installations in the Greater Phoenix Metropolitan Area and throughout Arizona.

Except for native plants like cacti and succulents that can survive on rainwater after a 1 – 2 year establishment period, newly installed "xeriscape" landscaping (a combination of native and arid-adapted plants) are typically irrigated through a permanent underground system to maintain the plantings' health and viability. It is not uncommon with a native plant installation to use water trucks, temporary above-ground systems, or a lower-cost underground system (poly pipe), making it feasible to either abandon the system in place after a few years or to use it only during times of extended drought. Regardless of which watering method is used, maintenance personnel routinely monitor the water being delivered to their landscaping.

For the near term, it is hoped that an even greater level of monitoring and documentation will occur after the GI treatments identified in this Handbook are installed, so that knowledge of the irrigation performance and related considerations can be better understood.

MAINTENANCE

One of the most recurring concerns expressed by local maintenance staff about implementing GI/LID has been the effect that such a paradigm shift would have on maintenance activities and costs. An additionally noted concern relates to the long-term viability of LID treatments. The GI treatments proposed in this Handbook cannot resolve all concerns or potential impacts that may result from their implementation, since there are numerous factors that contribute to maintenance costs. However, we have incorporated features into the LID details to ease the effort needed to

maintain the installations. For example, sediment traps have a smooth bottom to allow easy scooping of the captured materials; this design will help maintenance personnel to efficiently do their jobs.

Regardless of the efficiency built into the details as noted above, a routine activity that impacts maintenance costs is the extent of trimming and pruning that might result from enhancing the growing conditions of GI plantings. A key method for offsetting this long-term effort is to select plants carefully, to be mindful of their size at maturity, and their position relative to the inundation zones. Increased diligence on plant selection and adopting this strategy will avoid issues such as placing plants in improper locations or installing plants that will overgrow their available space, thereby increasing the need for pruning.

Allowing the installed plants to grow into their natural shape will reduce maintenance costs related to pruning. Additionally, because they have been placed in locations where stormwater is collected and because LID treatments have been enhanced to capture and percolate stormwater, they will generate volunteer vegetation growth, primarily

in basin bottoms, if not otherwise precluded. Volunteers are generally acceptable unless they interfere with the overall performance of the GI facility. While the resultant naturalized landscape appearance may be less "manicured" than current practices, it should gain overall acceptance as the benefits of GI become known to the public and maintenance managers.

As GI is more widely implemented in the Greater Phoenix Area, the body of knowledge about the optimum maintenance practices necessary to keep these treatments operating effectively for many years will be developed.

Key questions about maintenance include which are the high performing plants or plant groups; which plants are most maintenance-intensive or subject to disease and pest damage; whether LID plantings require less supplemental water; how often LID facilities need to be maintained; what type of maintenance is most effective (i.e., pruning, debris removal, soil refurbishment, etc.); how long before the treatments become "clogged"; and how the cost of LID facility maintenance compares to standard maintenance practices. Further, in the future, monitoring how and to what extent LID/GI contributes to broader social benefits such as improving air quality and encouraging environmental awareness will be important for gauging the full benefits of this approach.

RECOMMENDATIONS AND GUIDELINES

DESIGN CONSIDERATIONS

This section contains design and maintenance recommendations plus guidance on the suitability of specific plants for side slopes and bottoms of water harvesting basins, bioretention systems, bioretention planters, and curb extensions—based on their tolerance for different (higher or lower) levels of inundation. These guidelines are offered for initial consideration and should be evaluated for applicability at each development site by a qualified landscape architect or horticultural specialist. In general, seeding will be associated with larger-scale facilities in more rural settings and will depend on the performance objectives of the facility.

LANDSCAPING DETAILS AND SPECIFICATIONS

RECOMMENDATIONS

- Where space is available, trees and shrubs should comprise the majority of the plantings because of their longevity and ability to affect surrounding ground temperatures.
- Create landscape groupings with appropriate plant densities, to avoid over-competition for available moisture.
- Plan for the mature size of plants to avoid vegetation from overhanging streets and sidewalks or growing into overhead power lines.
- Grasses, low-growing groundcovers, and organic mulches are the preferred surface materials for LID facilities. The site location, context, and facility purpose will determine whether volunteer vegetation is appropriate.
- Vegetation should be monitored monthly.
- Plantings should be allowed to grow naturally, with little or no pruning, other than the removal of dead or damaged limbs and branches or to address pest control. Plants that bend under flow conditions should be considered for channel and pass-through situations. Vegetation that impairs sight visibility or presents a hazard to pedestrians should be pruned or removed. Shearing should not be a standard practice (particularly shearing of plants into geometric shapes).
- Dead, damaged, and invasive vegetation should be cleared and replaced with like kind or desirable plant species.

- Leaves, flowers, and seed pods (natural litter) that accumulates under the grasses and beneath the plants should be allowed to remain, to provide an organic mulch layer for moisture retention and to improve the soil medium.
- Leaf raking and vegetative debris removal should be undertaken only when it is evident that not doing so would reduce the effectiveness of the LID treatment.
- Weed control is most important during the first several years of establishment, and thereafter should be done on an as-needed basis. The use of herbicides is discouraged; hand-weeding of volunteer, invasive plants such as fountain grass, African sumac, and Mexican palo verde is preferred.
- Plants should be irrigated only as much as necessary to maintain health; overwatering encourages excessive growth.
- The irrigation system should be checked monthly and more frequently during hotter months to ensure proper functioning.
- Non-organic litter and other debris that accumulates as a result of runoff should be removed as needed.
- Sustainable landscape maintenance practices are encouraged.

NATIVE SEEDING

Native seeding should be considered on a case-by-case basis, depending on GI/LID objectives.

GUIDELINES

The following pages provide planting guidelines for GI projects in the Greater Phoenix Metropolitan Area.

SPECIFICATIONS

Important considerations for GI landscape specifications follow the Guidelines.

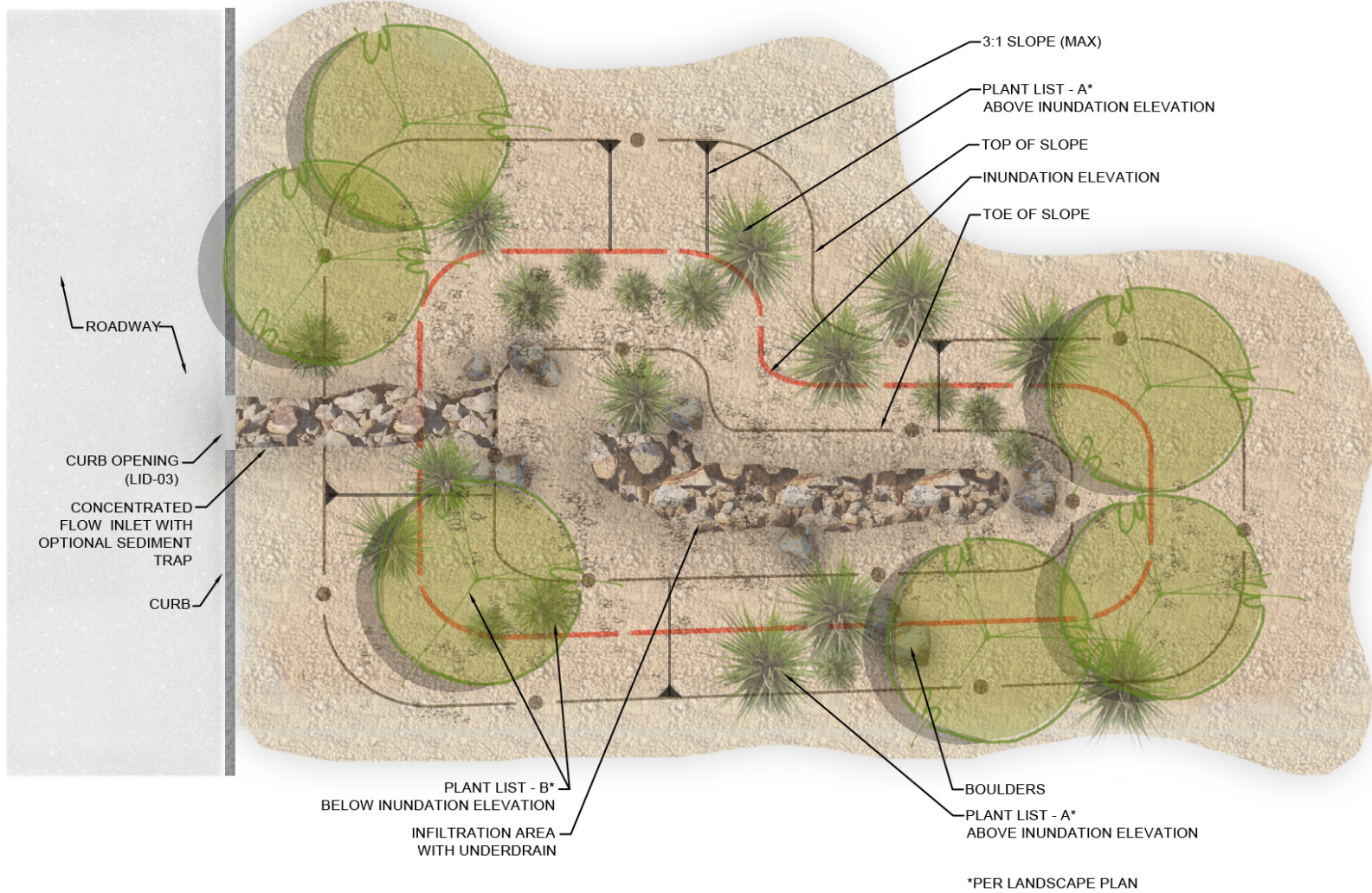

LID 5 STORMWATER HARVESTING BASIN - PLAN
N.T.S.

LANDSCAPING DETAILS AND SPECIFICATIONS

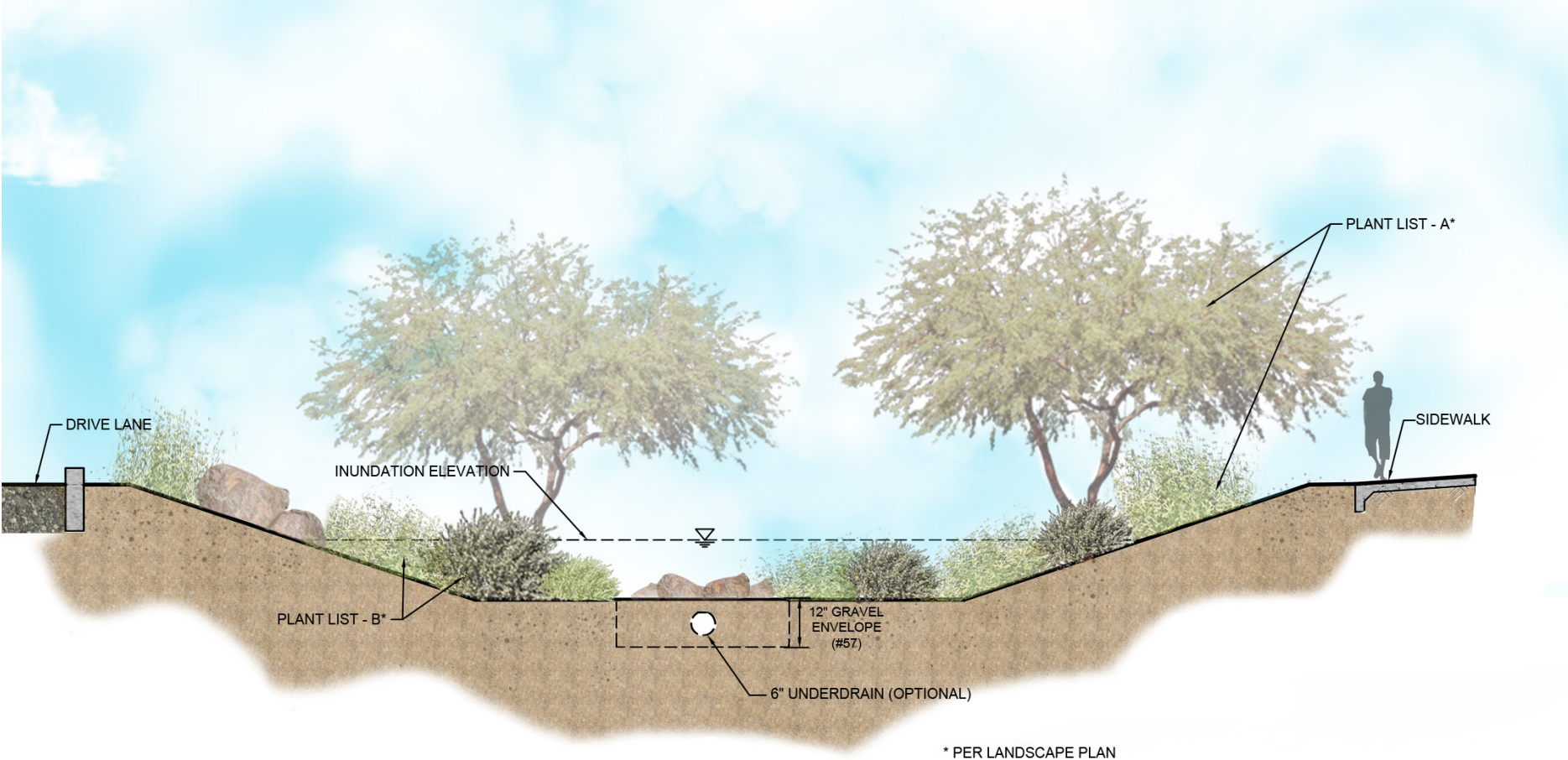

LID
5 | STORMWATER HARVESTING BASIN - SECTION
N.T.S.

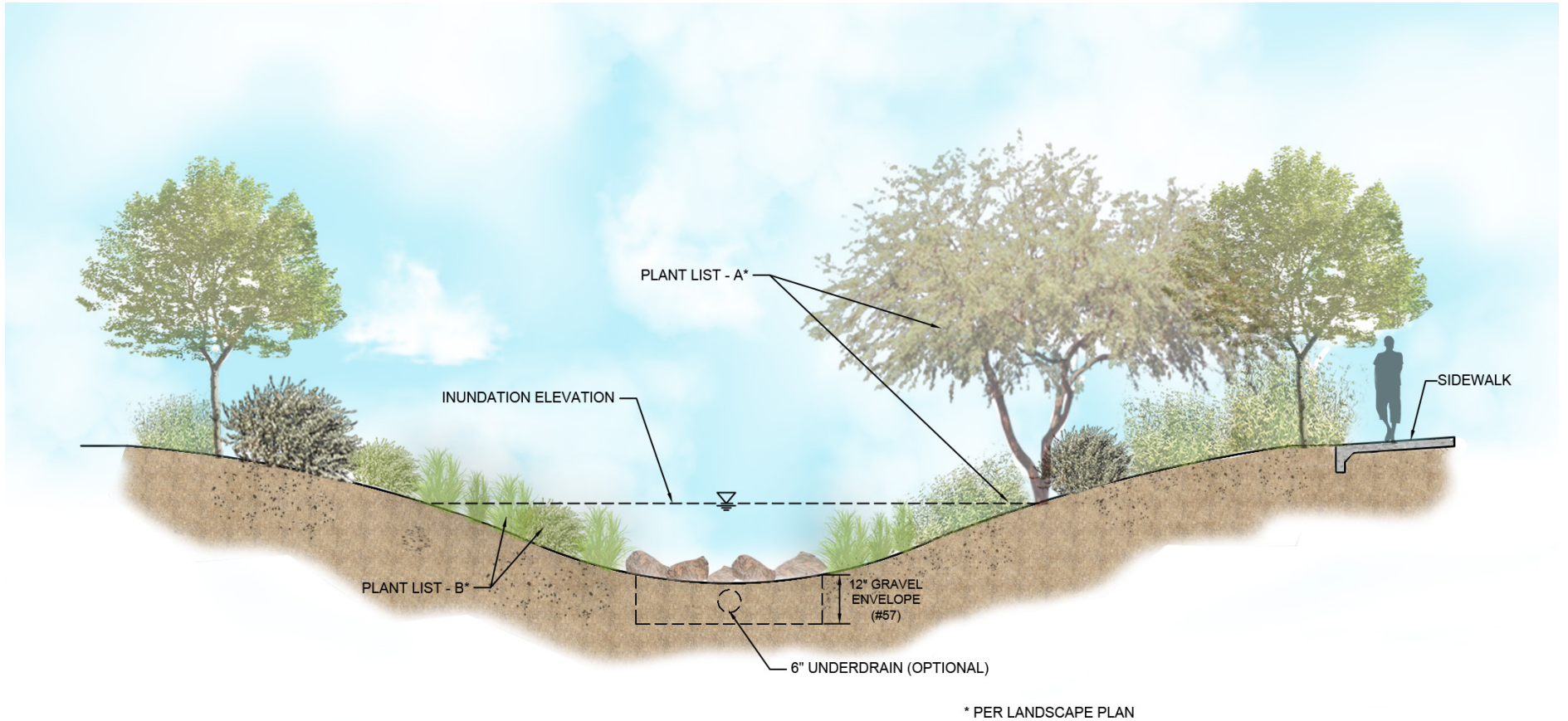

LID
6 BIOSWALE
N.T.S.

LANDSCAPING DETAILS AND SPECIFICATIONS

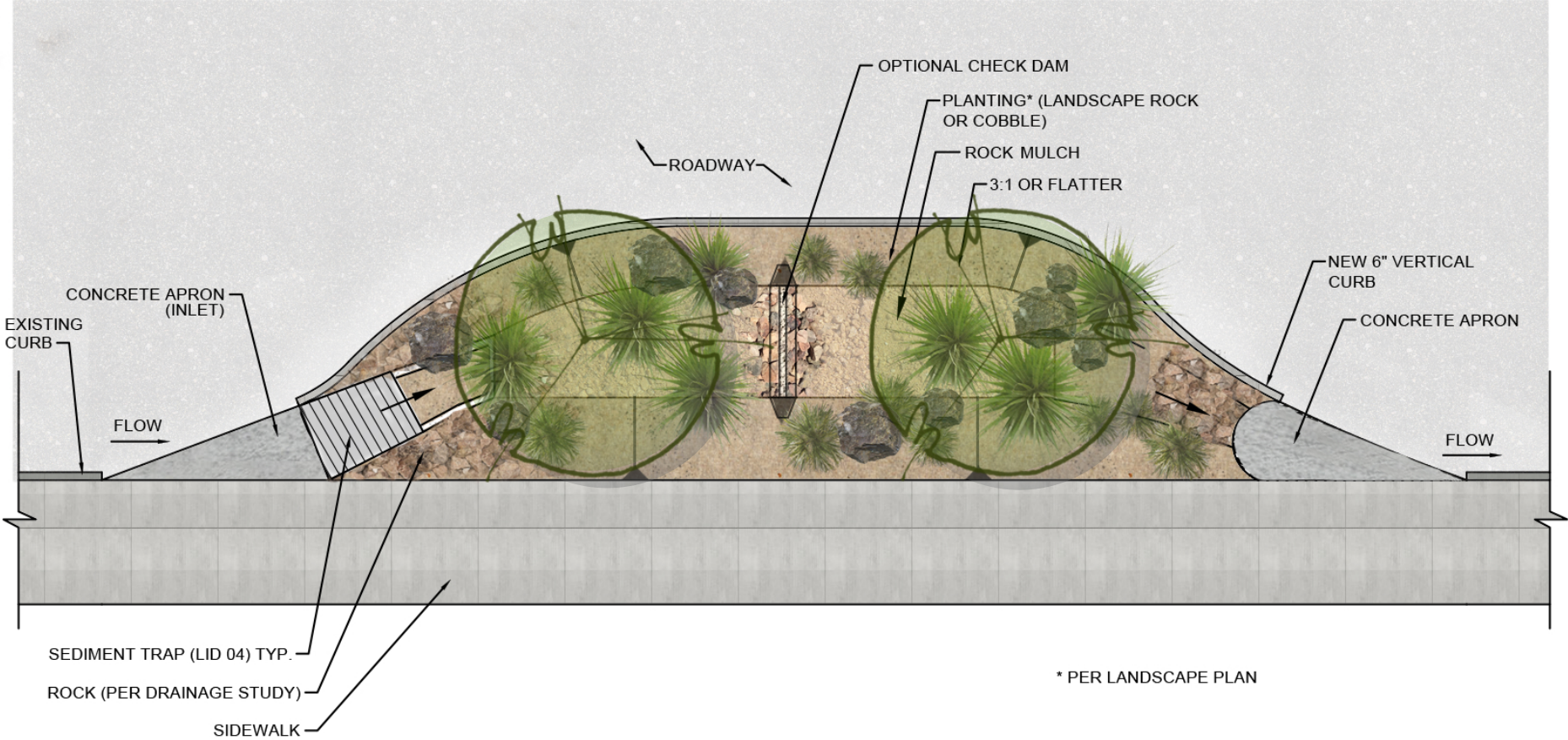

LID
8 CURB EXTENSION
 N.T.S.

PLANT LIST A

(ABOVE THE INUNDATION ELEVATION)

* Indicates plants native to Maricopa County

Botanical Name	Common Name
TREES	
Acacia aneura	Mulga
Caesalpinia cacalaco	Cascalote
*Chilopsis linearis	Desert-willow
*Olneya tesota	Ironwood
*Parkinsonia florida	Blue Palo Verde
*Prosopis pubescens	Screwbean Mesquite
*Prosopis velutina	Velvet Mesquite
Vachellia (Acacia) farnesiana	Sweet Acacia

SHRUBS

*Ambrosia deltoidea	Triangleleaf Bursage
Caesalpinia mexicana	Mexican Bird of Paradise
Caesalpinia pulcherrima	Red Bird of Paradise
Calliandra californica	Baja Red Fairy Duster
*Calliandra eriophylla	Fairy Duster
Cordia parvifolia	Littleleaf Cordia
*Encelia farinosa	Brittlebush
*Larrea tridentata	Creosote Bush
Leucophyllum frutescens	Texas Ranger
Leucophyllum laevigatum	Chihuahuan Sage
Ruellia peninsularis	Desert Ruellia
*Senegalia (Acacia) greggii	Catclaw Acacia
Senna artemisioides	Feathery Senna
*Simmondsia chinensis	Jojoba
*Vachellia (Acacia) constricta	Whitethorn Acacia
*Viguiera parishii (deltoidea)	Goldeneye

Please see Appendix C for additional plant lists.

PLANT LIST B

(BELOW THE INUNDATION ELEVATION)

* Indicates plants native to Maricopa County

Botanical Name	Common Name
TREES	
Brahea armata	Mexican Blue Fan Palm
Phoenix dactylifera	Date Palm
Washingtonia filifera	California Fan Palm
Prosopis velutina	Velvet Mesquite
Prosopis pubescens	Screwbean Mesquite
Parkinsonia florida	Blue Palo Verde
Eucalyptus spathulata	Swamp Mallee
Prosopis hybrid	South American Hybrid Mesquite
Eucalyptus microtheca	Coolibah Tree

SHRUBS

*Ambrosia ambrosioides	Giant Bursage
*Atriplex canescens	Fourwing Saltbush
*Atriplex lentiformis	Quail Bush
*Baccharis sarothroides	Desert Broom (male, non-seeding plants only)
*Celtis ehrenbergia (pallida)	Desert Hackberry
*Hymenoclea monogyra	Burrobrush
*Justicia californica	Chuparosa
*Lycium andersonii	Anderson Thornbush
Maytenus phyllanthoides	Mangle Dulce
Ruellia brittoniana	Purple Ruellia
*Senna covesii	Desert Senna
*Sphaeralcea ambigua	Globemallow
Tecoma stans	Yellow Bells
*Zizyphus obtusifolia	Graythorn

GRASSES

*Aristida purpurea	Purple Threeawn
Muhlenbergia capillaris	Pink Muhly
*Muhlenbergia rigens	Deer Grass
*Pleuraphis (Hilaria) rigida	Big Galleta

LANDSCAPING DETAILS AND SPECIFICATIONS

SECTION 215 EARTHWORK FOR OPEN CHANNELS

Excavation and placement of BSM for GI/LID projects shall conform to Section 215 of the MAG Uniform Standard Specifications, 2018 Revision to the 2015 Edition, and as specified herein.

215.1 DESCRIPTION:

Add the following:

Sections 430, 440, and 795 of the Standard Specifications and these special provisions contain requirements that apply to this Section.

215.3 EXCAVATION:

Add the following:

Delineate the limits of the GI installation. Upon approval of delineation, stakes, temporary construction fencing, or similar materials shall be placed as directed by Engineer to maintain limits of work.

If the BSM installation location has been used as the site for an erosion and sediment control measure, remove all remnants of prior use of the location, including all collected sediment and debris.

Excavation and grading shall be accomplished using low-impact earth-moving equipment to prevent compaction of the underlying soils. Wide-tracked vehicles such as backhoes, small dozers, and skid-steers are recommended. Excavating equipment should operate from the side of the basin to the extent feasible. Excavation methods should consider the excavation and installation of underdrains, if included in the contract documents.

If excavation leads to substantial compaction of the subgrade, the compacted area shall be removed and replaced with acceptable soil material to a depth approved by the Engineer.

Do not excavate, place BSM, or amend the installation during wet or saturated weather conditions. Excavations shall result in subgrade surfaces that are friable, firm, but not compacted and shall be in accordance with the lines and grades indicated in the contract documents. Roughen subgrade surfaces to remove smears, glazing, compacted areas, and equipment marks.

After subgrades are established for each stormwater harvesting basin, bioretention system, curb extension, or bioretention planter, a minimum of two percolation tests should be completed for each 40,000 square feet of excavation area. A minimum of one percolation test shall be completed for each, regardless of the size of the excavation area. For rock or vegetated bioswales, one percolation test shall be completed for each 750 linear feet of swale.

To conduct the percolation test, the test hole shall be 12 inches by 12 inches square or 15 inches in diameter by at least 12 – 18 inches deep. Do not alter the structure of the soil during the excavation. Scarify or loosen smeared soil surfaces within the test hole; remove loosened materials from the bottom of the hole.

The percolation test(s) shall be conducted in accordance with AAC R18-9-A310(F). The percolation test(s) shall be conducted during a daylight work shift so it can be observed by the Engineer. Percolation test results shall be reported in minutes per inch of water surface drop within the test hole. Alterations to the work, such as modifications to the subgrade soils, installation

of drainage chimneys, or the construction of an underdrain will be determined by the Engineer based on the findings of the percolation test(s). Alterations to the work will be measured and paid for in accordance with the requirements of MAG Section 104.

Where indicated in the contract documents, scarify, rip, or till the subgrade to a depth of 6 – 8 inches by hand or with equipment with tines spaced no greater than 8 – 12 inches apart. Scarification shall occur subsequent to percolation tests once soils are dry and prior to placement of BSM or rip rap/rock and landscaping for bioswales and basins.

215.4 FILL AND BACKFILL:

Add the following:

BSM PRODUCTION:

BSM may be produced from excavated or imported soil materials, including soil excavated from work areas outside the boundaries of the GI installation, provided it meets the requirements of these special provision and the imported material and material source is approved by the Engineer. At the contractor's option, BSM may be manufactured in bulk from the excavated/imported materials. The contractor shall accept complete responsibility for the planning and management of the BSM collection, storing, stockpiling, ensuring that the BSM remains as a homogenous mixture while stored and until installed, and the accuracy of the quantities necessary to provide and install all BSM work as indicated in the contract documents. The collection and mixing of the material in bulk shall not commence until direction is provided by the Engineer.

To be acceptable for use, excavated or imported soil material must be fertile, friable, and free from nut grass, refuse, construction debris, roots, substantial sand or dense clay pockets, clods, noxious weed seeds, fertilizers, chemicals, or other deleterious materials toxic to plant growth and viability. Soil shall meet the gradation requirements for topsoil in MAG Subsection 795.2, except that the #200 shall not exceed 30 – 40 percent passing. If imported soil is used, material may not be brought to the site until material has been approved by the Engineer. Soil shall also meet or be modified to meet the following requirements:

Calcium	2500 – 7000 parts per million (ppm)
Magnesium	150 – 400 ppm
Sodium	<300 ppm
Potassium	120 – 800 ppm
Manganese	<50 ppm
Zinc	<30 ppm
Copper	<10 ppm
Nitrate-n	28 – 35 ppm
Phosphate-p	22 – 28 ppm
Boron	0.5 – 2.0 ppm
Sulfur	20 – 200 ppm
Ec	<0.3 dS/m

As soon as possible after the area to be excavated or the import material source is accessible, contract with a licensed soils lab to take a minimum of 1 soil sample (0 – 1 foot depth) of the existing in-situ soil and 2 soil samples (0 – 1 foot depth) for each import source location. Agricultural fertility analyses showing ppm of the collected samples

shall include the criteria above, at a minimum, and all characteristics necessary to make fertility recommendations for landscape installations. Also include levels of salinity, pH, sodium, and free lime. Provide recommendations for soil amendments to correct any nutrient deficiencies, eliminate conditions detrimental to plant growth and/or to improve the soil fertility. Testing shall be conducted no more than 60 days prior to use on the project. Batch-specific testing will be required for all installations. Provide the fertility test results and recommendations to the Engineer for review.

BSM MIXING:

BSM shall be a mixture of soil, sand, compost, amendments, and fertilizers that supports plant growth while absorbing moisture and attenuating pollutants. The composition of the mixture shall be (by volume):

Excavated or Imported Soil:	75%
Sand:	15%
Fine Compost:	10%
Gypsum:	5 pounds per cubic yard of BSM
Sulfur:	1 pound per cubic yard of BSM
Fertilizer:	As indicated in the contract documents
Ec:	<0.3 dS/m

BSM mixing shall be as approved in the procedures manual described in Section 430 of these special provisions. Mixing is not allowed within the BSM placement pits or excavation area.

Upon completion of the BSM mixing, a 1 cubic foot sample of BSM product shall be provided to the Engineer.

As part of this work, the following analysis shall also be completed and provided to the Engineer:

1. Grain size analysis of the soil material shall be performed in accordance with ASTM D422, Standard Test Method for Particle Size.
2. Compost testing shall be performed in accordance with ASTM F 1647, Standard Test Methods for Organic Matter Content of Athletic Field Rootzone Mixes or Testing Methods for the Examination of Compost and Composting (TMECC) 05.07A, Loss-on-Ignition Organic Matter Method, and as required to demonstrate compliance with Subsection 795.3 of these special provisions.
3. Constant head permeability testing of the BSM in accordance with ASTM D2434, Standard Test Method for Permeability of Granular Soils (Constant Head) shall be conducted on a minimum of 2 samples with a 6-inch mold and vacuum saturation.
4. Hydraulic conductivity rate of the BSM should not be less than 3 inches per hour when tested with a double ring infiltrometer in accordance with ASTM D 3385, Standard Test Method for Infiltration Rate of Soils in Field Using Double Ring Infiltrometer, a single ring infiltrometer, a modified Philip-Dunne infiltrometer, or other approved methods.

LANDSCAPING DETAILS AND SPECIFICATIONS

Provide information about the laboratory(ies) conducting the testing, including name, address, contact person, phone number and email, and qualifications and certifications for ASTM/US Department of Agriculture testing.

Ship or delivery BSM materials with Certificate of Inspection required by governing authorities. Before delivery, Certificates of Compliance shall be submitted, certifying that materials meet or exceed the requirements specified, including physical property, and performance. Prior to shipment, provide certified copies of the reports for the Engineer's approval. Certification shall indicate the supplier's name, address, telephone number, date of purchase, name and technical description of item purchased, and quantity of each item purchased. Material samples shall be forwarded in a single package to the Engineer within 2 weeks after award of the bid. Certified copies of the documentation shall be provided for the following materials:

1. PVC pipe for the cleanout riser
2. Geosynthetic fabric

If, in the opinion of the Engineer after review of any or all testing, a change is warranted to the BSM components, component ratios, soil amendments, or other fertilizers, the Engineer may request a proposal for making alterations to the work. Changes to soil amendments from those shown in the contract documents may be covered by an adjustment in contract price for the affected items as approved by the Engineer.

BSM PLACEMENT:

BSM shall be placed uniformly in the designated areas to the depths and grades indicated in the contract documents. The contractor shall place BSM in 6 – 8 inch lifts. The initial lift shall be placed in a manner that reduces stratification and air pockets at the interface with the scarified subgrade.

After each layer has been placed, the BSM shall be foot compacted by contractor personnel and water settled so that the fluff and air pockets are substantially reduced. Add additional material as necessary to achieve the finished grade.

Avoid over-compacting and over-watering in the placement and spreading operation. Over-compacted areas shall be loosened or scarified as directed by the Engineer.

Prior to planting, vehicles, foot traffic, and construction equipment shall not be allowed to drive on, move over, or disturb the BSM once placed and water settled.

If indicated in the contract documents, a cleanout riser shall be installed. The riser shall be wrapped with a geosynthetic. The riser and geosynthetic shall be as described in Section 795 of these special provisions. Maintain placement of the fabric during the BSM filling operation so that the full height of the riser is protected by fabric after the filling operation is complete.

The contractor shall properly dispose of excess BSM.

215.8 PAYMENT:

Add the following:

Alterations to the work will be measured and paid for in accordance with the requirements of MAG Section 104.

Traffic control, if required for the project, shall be in accordance with the Phoenix Barricade Manual upon approval by the Engineer and is considered as incidental to the contracted items. No separate measurement and payment will be made for this work.

SECTION 430 LANDSCAPING AND PLANTING

Landscaping for GI/LID projects shall conform to Section 430 of the MAG Uniform Standard Specifications, 2018 Revision to the 2015 Edition, and as specified herein.

430.1 DESCRIPTION:

Add the following:

As indicated in the contract documents, landscaping shall be installed in stormwater harvesting basins, rock or vegetated bioswales, bioretention systems, curb extensions, and bioretention planters. Native seeding may also be installed in stormwater harvesting basins and rock or vegetated bioswales as indicated in the contract documents.

Sections 215, 440, and 795 of the Standard Specifications and these special provisions contain requirements that apply to this Section.

Perform work in accordance with all applicable laws, codes, and regulations required by authorities having jurisdiction over such work and provide for all inspections and permits required by federal, state, and local authorities in furnishing, transporting, and installing materials as indicated and for completing the work identified herein.

Cooperate and coordinate with other contractors and trades working in and adjacent to the work areas.

Comply with MAG and Arizona 811 requirements related to locating underground utilities. Determine location of underground utilities and perform work in a manner that will avoid possible damages. Maintain flags, stakes, or paint markings by others until removal is mutually agreed upon by the affected parties. Hand excavate, as required when working in close proximity to any underground utilities. At no additional cost to the project, repair all damages to located utilities as approved by the Engineer.

430.2 GENERAL:

Add the following:

Furnish all labor, materials, equipment and incidental needs to install the landscape installation to the lines, grades, cross sections, and details indicated in the contract documents.

Existing utilities and improvements not designated for removal shall be protected in place. Any damages will be repaired by the contractor at no additional cost to the project.

Unless otherwise stated, planting, irrigation, native seeding, and other improvements shall be installed in concert with the finish grade construction.

The contractor shall bear final responsibility for proper surface drainage of planted areas. Any discrepancy in the drawings or these special provisions, obstructions on the site, or prior work done by another party, which contractor feels precludes establishing proper drainage, shall be brought to the attention of the Engineer in writing for correction or relief of said responsibility prior to start of operations.

All landscape areas within the project shall be graded so that finished surfaces conform to the typical sections, proposed lines and grades, and surrounding surfaces as indicated in the contract documents. Finished surfaces shall be reasonably smoothed, compacted, and free from irregular surface drainage.

For landscape installations, finished grades shall have a vertical tolerance of ± 0.1 foot from the specified grade and cross section.

Weed control shall be completed by hand or mechanical means.

Applicable publications listed below form a part of this specification to the extent referenced:

- American Association of Nurserymen, Inc. (AAN): American Standard for Nursery Stock (ASNS), 1986 Edition.
- American Joint Committee on Horticultural Nomenclature (AJCHN): Standardized Plant Names (SPN), Second Edition, 1942.
- Arizona Nursery Association Growers Committee (ANA): Recommended Tree Specifications, latest edition.

Ship materials with certificate of inspection required by governing authorities. Before delivery, certificates of compliance shall be submitted, certifying that materials meet the requirements specified.

Unless otherwise specified, the contractor shall perform all testing, or provide test results to the Engineer from accredited laboratories. The contractor shall pay the cost for all testing in addition to all removal and replacement of materials not meeting these special provisions.

The Engineer reserves the right to take and analyze samples of materials for conformity to these special provisions at any time. Contractor shall furnish samples upon request. Rejected materials shall be immediately removed from the site at the contractor's expense.

Procedures Manual: Within 14 days of award of the bid, submit a procedures manual identifying the methods/procedures proposed by the contractor to complete the landscape installation work. The manual shall specifically identify the proposed sources of materials and component mixture ratios to produce the BSM material testing methods for the individual BSM components, and the overall mixture, equipment, and methods for mixing and placing the BSM, BSM settling/compaction procedures, details and methods proposed for planting the plants, including excavating the plant pits, backfilling techniques, watering, staking, bracing, fertilizing, and maintenance of the installation during the maintenance and warranty period. The manual shall also include descriptions of modifications and protection of the installation for seasonal climatic conditions/events such as monsoon storms or frost. The manual shall also

LANDSCAPING DETAILS AND SPECIFICATIONS

identify any anticipated temporary, on-site plant storage areas, if used, and their proposed watering system, plus recommendations for herbivore protection, if indicated in the contract documents.

The manual will be reviewed by the Engineer who reserves the right to request further information on the methods proposed by the contractor.

Upon written acceptance and agreement by the Engineer, the procedures manual shall be modified as agreed-upon and included as part of these Special Provisions and shall govern the requirements of those portions of the work therein. Resubmit the procedures manual with agreed-upon modifications.

430.4 DECOMPOSED GRANITE AREA:

Add the following:

Landscape areas to receive decomposed granite or an organic mulch shall be graded according to the contract documents prior to the placement of any rock material. The ground shall be reasonably smooth and rocks larger than 1 inch in diameter within the top 1 inch of the ground surface, shall be removed and disposed of off-site.

Decomposed granite shall be evenly distributed on the designated areas to a depth as indicated in the contract documents. If a depth is not indicated the minimum depth shall be 2 inches. Pre-emergents shall not be used unless specifically called out in the contract documents.

After placing and grading the decomposed granite, the contractor shall water-settle the decomposed granite with a light spray to remove fine materials from the surface. Do not roll the decomposed granite.

At the locations specified in the contract documents, an organic mulch may be placed as the surface plating material. Organic mulch shall be evenly distributed on the designated areas to a depth as indicated in the contract documents. If a depth is not indicated the minimum depth shall be 3 inches.

430.5 TREE, SHRUB AND GROUND COVER PLANTING:

Add the following for BSM installations:

Setting and Backfilling for Trees and Shrubs:

Excavate plant pit in sufficient size to install the root ball. When set, place BSM around root ball. Water thoroughly to remove air pockets after backfill is complete. Add BSM as required to achieve finished grade. Repeat watering as necessary to settle BSM.

In the event ambient air temperature is greater than 110° F, the contractor shall pre-wet all plant pits prior to installing trees, shrubs, or groundcovers. Do not install plant material until all water has fully percolated out of the plant pit into the surrounding BSM, do not allow plant pit sides or bottom to excessively dry out prior to planting operations.

Stake all trees per the contract documents. Avoid "rigid" restraint of tree and allow for some trunk movement.

430.5.1 Substitutions:

Add the following:

If the specified planting materials are not obtainable prior to the installation, submit proof of non-availability from three sources within 14 days of award of the bid along with recommendations for at least 2 – 3 suitable plant substitutions.

430.5.2 Plant Inspection Prior to Delivery to the Project Site:

Add the following:

The contractor will pay for the Engineer's travel to nurseries located outside of the Phoenix Metropolitan Area.

430.5.7 Clean Up:

Insert the following subsection:

Any material placed or deposited in non-designated areas shall be immediately removed at the contractor's expense. Non-designated areas may include, but are not limited to, do not disturb areas; structures; walls; fences; pavement; roads; trails/paths; signs; trees; plants; site furnishings; and equipment.

430.8 PLANT GUARANTEE AND MAINTENANCE:

Add the following:

Warranty all plant material for a period of 1 year after final acceptance of landscape installation against defects, including death and unsatisfactory growth, except for defects resulting from neglect by the Engineer, vandalism, abuse or damage by others, or unusual phenomena or incidents which are beyond the contractor's control. Remove and replace plant material found to be dead or in

unhealthy condition at any time during warranty period or as directed by the Engineer. Replace plant material that is in doubtful condition at the end of the warranty period, unless, in opinion of Engineer, it is advisable to delay replacement.

Only one replacement (per tree, shrub, or cacti) will be required during the warranty period, except for loss or replacements due to failure to comply with specified requirements.

Replacements made during the warranty period shall be completed within 7 days of written notice from the Engineer. The Engineer shall approve replacement material prior to planting.

Unless otherwise authorized, the Contractor shall maintain all landscape areas during the plant establishment period on a continuous basis as they are completed during the course of work and until final acceptance by the Engineer. Maintenance shall include keeping the landscape areas free of debris, control of undesirable weeds and vegetation or infestations that would jeopardize the growth of planted materials, fertilization as needed, cultivating the planting areas, and providing additional BSM to meet the finished grades indicated in the contract documents. Make replacements within 7 days of notification from the Engineer. Remove dead, damaged, or vandalized plants within 7 days of notification.

Replacements shall be of the same kind and size as originally specified and shall be installed as indicated in the contract documents. Replacements of vandalized plants and/or other installed items shall be measured and paid for in accordance with the requirements of MAG Section 104.

After planting, landscape areas shall be maintained as plants shall be inspected at least once a week and appropriate maintenance performed. Pruning is to include removal of any growth conflicting with vehicular or pedestrian movement and sight lines.

Pruning: Pruning shall be done so that an aesthetic framework of branches is left, which preserves the size and best features of the affected plant so that the plant will fill in for a balanced appearance. Pruning shall not damage the collar of the branch being removed. Current standards for arboriculture, such as ANSI A300 Pruning Standards, shall be used.

Trimnings for each plant shall be removed from the site and properly disposed of by the contractor on the same day as the trimming activity.

The contractor shall maintain the irrigation system and make any necessary repairs to assure a complete and operational system as originally designed and constructed. Repairs shall be made within 48 hours of detection.

If the landscape areas are improperly maintained, if appreciable plant replacement is required (for whatever reason excluding vandalism), if corrective work is required for the proper operation of the irrigation system, or if other corrective work is necessary, the plant guarantee and maintenance period shall be extended at the sole discretion of the Engineer; the contractor shall continue to maintain the entire site at no increased cost until final acceptance by the Engineer.

430.9 PLANT ESTABLISHMENT PERIOD:

Add the following:

The plant establishment period for the installed plants and irrigation system shall be 90 days, although a longer period may be indicated in the contract documents, and is exclusive of the allotted contract period.

Landscaping Installation Acceptance

Inspection: A pre-plant establishment period inspection will be performed upon substantial completion of all planting and irrigation work. The contractor shall notify Engineer within 5 days of inspection to arrange schedule. The Engineer, contractor and such others as the Engineer shall direct, shall be present at the inspection. The Engineer shall issue the effective beginning date for the 90-day plant establishment period for all or portions of the landscaping. Work requiring corrective action in the judgment of the Engineer shall be performed within 5 days after the inspection. Corrective work and materials replacement shall be in accordance with the contract documents and shall be made at no cost to the project. When inspected work does not comply with requirements, replace rejected work and continue specified maintenance until re-inspected by Engineer and found to be acceptable. Remove rejected plants and materials promptly from the project area.

Final Plant Establishment Inspection: At the end of the 90-day plant establishment period, a final inspection will be performed to accept the landscape installation. At the time of final establishment inspection, all planting areas under this contract shall be free of weeds and neatly cultivated. All plants shall be alive and healthy, without signs of stress. Landscape areas shall be

LANDSCAPING DETAILS AND SPECIFICATIONS

free of rills, rivulets, or erosion. An inspection of planting activities will be made by the Engineer in the presence of the contractor to substantiate that the completed work is in compliance with the requirements of the project. If, after the inspection, the Engineer is of the opinion that all work has been performed as per the contract documents and that all plant materials are in satisfactory growing condition, a written notice of final acceptance of the landscape installation and commencement of the 1-year warranty period will be issued.

Work requiring corrective action or replacement in the judgment of the Engineer shall be performed within 7 days after the final inspection. Corrective work and materials replacement shall be in accordance with the contract documents, and shall be made by the contractor at no additional cost to the project.

430.10 MEASUREMENT AND PAYMENT:

Add the following:

Alterations to the work will be measured and paid for in accordance with the requirements of MAG Section 104.

No separate measurement or payment will be made for the preparation and necessary modifications to the procedures manual as described herein. The work is considered incidental to the contracted items.

Traffic control, if required for the project, shall be in accordance with the Phoenix Barricade Manual upon approval by the Engineer and is considered as incidental to the contracted items. No separate measurement and payment will be made for this work.

SECTION 440 SPRINKLER IRRIGATION SYSTEM INSTALLATION

Irrigation installations for GI/LID projects shall conform to Section 440 of the MAG Uniform Standard Specifications, 2018 Revision to the 2015 Edition, and as specified herein.

440.1 DESCRIPTION:

Add the following:

Sections 215, 430, and 795 of the Standard Specifications and these special provisions contain requirements that apply to this Section.

As indicated in the contract documents, an automatic, underground irrigation system shall be installed in stormwater harvesting basins, vegetated bioswales, bioretention systems, curb extensions, and bioretention planters.

Irrigation systems shall be designed to allow for each type of LID treatment (stormwater harvesting basin, vegetated bioswale, bioretention systems, curb extensions, and bioretention planters) to be zoned independently from other LID treatments and from non-LID landscape improvements. For all treatments, trees and shrubs shall be valved separately.

SECTION 795 LANDSCAPE MATERIALS

795.4 ORGANIC SOIL CONDITIONERS:

Delete this subsection in its entirety and substitute with the following:

Compost shall be used as the organic soil conditioner. Compost shall consist of composted organic vegetative materials. Prior to being furnished on the project, compost mulch samples shall be tested for the specified microbiological and nutrient conditions, including maturity and stability, by a testing laboratory approved for testing of organic materials. Written test results shall be submitted to the Engineer for review and approval.

Compost material shall be dark brown in color with the parent material composted and no longer visible. The structure shall be a mixture of fine- and medium-size particles and humus crumbs. The maximum particle size shall be within the capacity of the contractor's equipment for application to the constructed slopes. The odor shall be that of rich humus with no ammonia or anaerobic odors.

Compost shall also meet these requirements:

Table 5. Compost

Cation Exchange Capacity (CEC)	Greater than 60 meq/100 g
Carbon: Nitrogen Ratio	Less than 20:1
pH (of extract)	6 – 8.5
Organic Matter Content	Greater than 25%
Total Nitrogen (not added)	Greater than 1%
Humic Acid	Greater than 5%
Maturity Index	Greater than 50% on Maturity Index at a 10:1 ratio
Stability	Less than 100 mb O ₂ /Kg compost dry solids – hour

795.8 MISCELLANEOUS MATERIALS:

Add the following items:

795.8.4 Decomposed Granite:

Decomposed granite used as a surface treatment shall be washed and screened (no fines) or as specified in the contract documents. Submit material certificates from material producer and contractor, certifying that the granite meets these requirements. Submit 5-pound samples of decomposed granite in colors and sizes specified in the contract documents. Verify in writing to Engineer that there is sufficient supply from single source to supply entire project.

795.8.5 Bioretention Soil Media:

Shall comply with the requirements of Section 215 of these special provisions.

795.8.6 Sand:

Shall meet the requirements of 701.3 Fine Aggregate (Sand) except that the size and gradation shall be as specified for natural sand in ASTM C144.

795.8.7 Perforated Cleanout Riser:

Riser shall be 3-hole PVC of the size indicated in the contract documents and comply with ASTM D2329 for non-pressurized pipe condition.

795.8.8 Geosynthetic Fabric:

Shall be a woven fabric complying with Class A of Table 796-2 of the MAG Standards.

Contact herbicides and pesticides used must comply with all applicable state and Federal laws and be registered with the U.S. Environmental Protection Agency. Contact herbicides shall be quick acting and permit planting within 7 – 10 days of their use. Herbicides, insecticides and fungicides shall be applied as needed and in accordance with the manufacturer's recommendations.

GLOSSARY

Abstraction: The maximum amount of rainfall absorbed without producing runoff

Best Management Practices (BMP): Methods or techniques found to be the most effective and practical means in minimizing pollution while making the optimum use of the feature.

California bearing ratio (CBR): CBR is a penetration test for evaluation of the mechanical strength of natural ground, subgrades and base courses beneath new construction

Cubic feet per second (cfs): The volume of water flowing past a given point

Design storm: Recurrence interval storm over an identified time frame

Detention: Runoff Storage Area that detains water before it is released into a downstream conveyance facility

Head pressure: The internal energy of a fluid due to the pressure exerted on the boundary .

Heat island phenomenon: A phenomenon that occurs in developed areas where the replacement of natural land cover with paving, buildings, roads, and parking lots results in an increase in outdoor temperatures

Hydraulic radius (area / wetted perimeter) (R): Hydraulic parameter that is the area divided by the wetted perimeter.

Hydrologic soil type: Draining characteristics of the soil

Infiltration: Infiltration is the process by which water on the ground surface enters the soil. Infiltration rate in soil science is a measure of the rate at which soil is able to absorb rainfall

Median diameter of the soil (d50): Particle Size Distribution D50 is also known as median diameter or medium value of particle size distribution, it is the value of the particle diameter at 50% in the cumulative distribution.

Right-of-way (ROW): The right of way may be a specific grant of land or an "easement," which is a right to pass across another's land

"Softer" streets: Streets that have more vegetation, landscaping, and lower speeds

Standard proctor density (SPR): The Proctor compaction test is a laboratory method of experimentally determining the optimal moisture content at which a given soil type will become most dense and achieve its maximum dry density

Time of concentration: The time required for a drop of water to travel from the most hydrologically remote point in the subcatchment to the point of collection.

REFERENCES

1. ***Low Impact Development and Green Infrastructure Guidance Manual***, Pima County and the City of Tucson, March 2015.
2. ***Drainage Policies and Standard for Maricopa County***, June 2016.
3. ***Low Impact Development – Technical Guidance Manual for Puget Sound***, Puget Sound Partnership, December 2012.
4. ***Field Survey of Permeable Pavement Surface Infiltration Rates***, Journal of Irrigation and Drainage Engineering 133(3):247–255, Bean, E.Z., W.F. Hunt, and D.A. Bidelspach, 2007.
5. ***Increasing Exfiltration from Pervious Concrete and Temperature Monitoring***, Journal of Environmental Management 90:2636–2641, Tyner, J.S., W.C. Wright, and P.A. Dobbs, 2009.
6. ***Urban Runoff Mitigation by a Permeable Pavement System Over Impermeable Soils***, Journal of Hydrologic Engineering 15(6):475–485. Fassman, E.A., and S.D. Blackbourn, 2010.
7. ***Impacts of Construction Activity on Bioretention Performance***, Journal of Hydrologic Engineering 15(6):386–394. Brown, R.A., and W.F. Hunt, 2010.
8. ***Are Bioretention Cells Being Installed per Design Standards in North Carolina: A Field Assessment***, Journal of Environmental Engineering 138(12):1210–1217, Wardynski, B.J., and W.F. Hunt, 2012.
9. ***Side-by-Side Comparison of Nitrogen Species Removal for Four Types of Permeable Pavement and Standard Asphalt in Eastern North Carolina***, Journal of Hydrologic Engineering 15(6):512–521, Collins, K.A., W.F. Hunt, and J.M. Hathaway, 2010.
10. ***AASHTO Guide for Design of Pavement Structures***, American Association of State Highway and Transportation Officials, 1993.
11. ***Supplement to the AASHTO Guide for Design of Pavement Structures – Part II***, American Association of State Highway and Transportation Officials, 1998.
12. ***San Antonio River Basin Low Impact Development Technical Guidance Manual***, San Antonio River Authority, Tetra Tech, 2015.
13. ***Drainage Design Manual for Maricopa County, Volume II***, Hydraulics. Flood Control District of Maricopa County, August 2013.
14. ***Roadway Design Guide***, American Association of State Highway and Transportation Officials, 2011.
15. ***Verification of Roughness Coefficients for Selected Natural and Constructed Stream Channels in Arizona***, U.S. Geological Survey for the Flood Control District of Maricopa County, 1998.
16. ***Uniform Standard Specifications and Details for Public Work Construction***, Maricopa Association of Governments, 2018.
17. ***Low Impact Development – Standards Manual***, County of Los Angeles Department of Public Works, February 2014.
18. ***Arizona Soils***, David M. Hendricks, University of Arizona, 1985.
19. ***IAS Labs***, Personal communication with Sheri McLane, July 2018.
20. ***Native Plants for Southwestern Landscapes***, Judy Mielke, University of Texas, 1993.
21. ***Low Impact Toolkit***, Cities of Mesa and Glendale, Arizona, 2015.
22. ***Watershed Management Group***, personal communication with Kieran Sikdar, June 2018.
23. ***Soil Science & Management***, 4th Edition, Edward J. Plaster, Thomson/Delmar Learning, 2003.

APPENDIX A: RAIN GAUGE MEASUREMENTS

Station No	Station Name	Data Begins:	Location	Number of Rainfall Events Observed	Number of Rainfall Events less than 0.5 inch	Ratio of rainfall events less than 0.5 inch
9900	Phoenix Dam 2B	6/29/2009	Thunderbird Rd. at 7th St.	205	170	0.83
9800	Dreamy Draw Dam	1/24/1984	1/4 mi. SSW of 24th St. & Dunlap Ave.	870	716	0.82
9300	Paradise Valley Country Club	7/11/1989	1/2 mi. N of Lincoln Dr. & Tatum Blvd.	797	675	0.85
89500	Bullard Wash @ Indian School Road	6/27/2006	Indian School Rd. @ Wigwam Blvd.	268	230	0.86
87800	White Tank FRS # 4	1/9/1986	1/4 mi. NE of Tuthill Rd. & Van Buren St.	633	547	0.86
87500	Camelback Rd. @ Citrus Rd.	5/10/2012	Camelback Road at Citrus Road	118	94	0.80
87300	White Tank FRS # 3	3/12/1986	4 mi. N of I-10 on the Jackrabbit Trail alignment	750	632	0.84
8700	East Fork Cave Creek Basin # 3	9/13/1994	1/2 mi. SW of Union Hills & Cave Creek Rd.	646	540	0.84
87000	Sun City West	3/30/1995	1/4 mi. SE of the Beardsley Rd. & Litchfield Rd. alignments	546	469	0.86
86700	Dysart Rd. @ Bell Rd.	10/25/1992	Dysart Rd. at Bell Rd.	622	523	0.84
86500	McMicken Dam South	2/13/2002	1/2 mi N of the Peoria and 195th Ave. alignments	353	296	0.84
86200	Ford Canyon Wash	2/5/2002	Alignments of Cactus and Tuthill Roads	396	316	0.80
85800	Dysart Drain @ Luke AFB	8/22/1996	1/4 mi. west of Northern Ave. & Litchfield Rd.	509	429	0.84
85500	Colter Channel @ El Mirage Rd.	6/29/1994	1/4 mi. N of Camelback and El Mirage Rd.	542	465	0.86
8500	E. Fork Cave Cr. near 7th Ave.	5/8/1997	1/2 mi. S of 7th Ave. & Greenway Rd.	585	503	0.86
85000	Agua Fria R. @ Buckeye Rd.	10/6/1988	Buckeye Rd. bridge over the Agua Fria River	704	592	0.84
84700	Mobile	12/15/2004	2 mi. SE of Mobile	292	249	0.85
84500	Upper Waterman Wash	6/23/1988	10 mi. WNW of Mobile	666	585	0.88
84200	Estrella Fan	11/15/1992	Alignments of El Mirage & Germann Roads	602	499	0.83
84000	Waterman Wash	5/10/1983	Alignments of Riggs & El Mirage Roads	815	679	0.83
83800	Gila River @ Estrella Parkway	2/28/1989	Estrella Pwky bridge over the Gila River	646	554	0.86
83500	Tuthill Rd. @ Ray Rd.	12/22/1994	1/2 mi. E of Tuthill and Ray Roads	491	429	0.87
83300	Waterman Wash @ Rainbow Valley Rd.	3/18/1999	Rainbow Valley & Queen Creek Roads	417	365	0.88
83000	Iron Dike	6/30/2009	4.5 miles NNE of Sunflower	410	313	0.76
82700	Bartlett Lake	8/31/2000	Bartlett Lake Sheriff Sub-station	579	455	0.79
82500	Horseshoe Lake	9/11/2000	Horseshoe Lake - SW corner near boat ramp	630	498	0.79

APPENDIX

Station No	Station Name	Data Begins:	Location	Number of Rainfall Events Observed	Number of Rainfall Events less than 0.5 inch	Ratio of rainfall events less than 0.5 inch
82200	Sycamore Creek - Upper	6/19/2012	8 miles N of Sunflower	312	243	0.78
8200	E. Fork Cave Cr. Basin # 4	1/18/1994	1/4 mi. S of Union Hills Dr. & 32nd St.	594	487	0.82
82000	Sycamore Creek - West Fork	6/19/2012	5 miles NNW of Sunflower	265	200	0.75
81500	Spookhill FRS @ Brown Rd.	6/4/2008	Brown Rd. @ Red Mtn. Loop 202	257	214	0.83
81300	Apache Junction FRS	12/16/1981	1/3 mi. NW of Lost Dutchman & Idaho Rd.	1093	900	0.82
81000	Thunder Mountain	4/1/1982	1/2 mi. W of the alignments of Ellsworth & Indian School Roads	964	808	0.84
80700	Usery Park Weather Station	2/24/1994	1/4 mi. WNW of Crismon & Thomas Roads	680	556	0.82
80200	Usery Mountain Park	6/20/1985	Alignments of McDowell & Crismon Roads	958	782	0.82
79800	Spookhill FRS @ McKellips Rd.	6/19/2008	McKellips Rd. @ Loop 202	265	215	0.81
79500	Signal Butte FRS	11/10/1987	1/4 mi. NE of Signal Butte & Brown Roads	845	709	0.84
79300	Hesperus Wash	3/10/1997	Near Dixie Mine on east side of McDowell Mtns.	670	538	0.80
79000	Hesperus Dam	12/18/1996	1/4 mi. N of Richwood Ave. & Golden Eagle Blvd.	581	473	0.81
78500	Golden Eagle Blvd.	2/12/1997	0.1 mi. E of Morning Dove Dr. & Golden Eagle Blvd.	621	493	0.79
78200	North Heights Dam	10/11/1996	1/4 mi. SW of Sierra Madre Dr. & Golden Eagle Blvd.	598	476	0.80
7800	E. Fork Cave Cr. Basin # 1	3/2/1994	1/4 mi. E of Beardsley Rd. & Cave Creek Rd.	666	549	0.82
77800	Cloudburst Wash	3/13/1997	2 mi. NW of Sun Ridge Golf Course	647	513	0.79
77500	Sun Ridge Canyon Dam	2/4/1997	Near Lago Blvd. & Palisades Blvd.	614	495	0.81
77300	Stone Ridge Dam	12/11/1996	1/4 mi. W of Cholla Dr. and Fountain Hills Blvd.	592	482	0.81
77000	Camp Creek	7/18/2005	4 mi. SE of Seven Springs Campground	495	369	0.75
76700	Fountain Hills Fire Dept.	12/9/1993	Near Palisades Blvd. & Fountain Hills Blvd.	715	584	0.82
76500	Rackensack Canyon	6/28/2007	8 miles NE of Cave Creek	387	292	0.75
76200	Fraesfield Mountain	8/2/1989	1/4 mile N of Dixileta Dr. and 128th St.	1008	786	0.78
76000	McDowell Mountain Road	5/18/2004	In McDowell Mtn. Park, 2 miles N of Fountain Hills	416	345	0.83
75800	McDowell Mountain Park	8/6/1990	4 mi. WSW of Rio Verde	944	751	0.80
75500	Asher Hills	8/2/1990	Off Asher Dr. in McDowell Mtn. Park, 1 mi. west of Rio Verde	865	703	0.81
7500	Grand Ave. @ Peoria Ave.	7/11/1996	Grand Ave. and Peoria Ave.	503	421	0.84

Station No	Station Name	Data Begins:	Location	Number of Rainfall Events Observed	Number of Rainfall Events less than 0.5 inch	Ratio of rainfall events less than 0.5 inch
75000	Granite Reef Diversion	7/21/2005	Bush Hwy. near Granite Reef Dam	359	299	0.83
74700	Spookhill FRS	3/13/1984	1/2 mi. N of McDowell & Bush Hwy.	916	754	0.82
74500	Vekol Wash	3/7/1990	North of I-8 bridge at Vekol Road	849	742	0.87
74200	Picacho Wash	4/11/2012	SR 74 at Cotton Lane alignment	168	139	0.83
73800	Upper Trilby Wash	9/25/2001	2.2 miles north of Castle Hot Springs Road on Trilby Wash	516	399	0.77
73500	Circle City	10/1/1982	US 60/93, 14 mi. SE of Wickenburg	1004	807	0.80
73400	Vistancia Peak	9/1/2015	5.3 mi. SW of Lake Pleasant	64	50	0.78
73300	CAP @ 163rd Ave.	12/10/2002	CAP canal at 163rd Ave.	371	295	0.80
73200	Twin Buttes Wash	10/1/2015	1/4 mi. SE of Vistancia Blvd. & El Mirage Rd	65	55	0.85
73000	Northwest Regional Landfill	4/27/1993	Near 195th Ave. and Deer Valley Road	581	478	0.82
72500	Wittmann	5/13/1992	60/93 at Wittmann, 4 mi. SE of Circle City	700	576	0.82
72200	Douglas Ranch Rd.	7/16/2013	3.5 miles N of Patton Rd. & Hassayampa R.	130	108	0.83
72000	Patton Road	5/13/1992	7 mi. W of Grand Ave. on Patton Rd.	659	530	0.80
71700	McMicken Dam	3/20/1983	1/4 mi SE of Deer Valley Rd. and Cotton Ln.	750	639	0.85
71500	McMicken Dam @ Bell Rd.	9/8/2016	Bell Road at Perryville Rd. alignment	30	24	0.80
71300	McMicken Floodway	5/19/1992	1/2 mile north of Grand Ave. and Deer Valley Rd.	587	492	0.84
71000	Sauceda Wash	2/28/1990	6 mi. SSW of Gila Bend on SR 85	607	527	0.87
70700	Gila River @ 116th Ave.	1/26/1989	1/4 mi. NNW of 115th Ave. & Baseline Rd.	732	616	0.84
70500	South Mountain Fan	6/9/1993	Alignments of Ray Rd. & 35th Ave.	565	481	0.85
70200	Ahwatukee	3/4/1996	1/4 mi. SSW of Warner Rd. & 44th St.	559	471	0.84
7000	Missouri Ave. @ 16th St.	1/17/1991	SW corner of Missouri Ave. & 16th St.	735	598	0.81
70000	Pecos Basin	1/6/2009	1/4 mi. SW of I-10 & Loop 202	234	208	0.89
69000	South Mtn. Park HQ	5/1/1997	Alignments of Elliot Rd. & 7th Ave.	646	568	0.88
68900	Dobbins Rd. @ 19th Ave.	9/15/2016	1/4 mi. NW of 19th Ave. @ Dobbins Rd.	28	24	0.86
68500	South Mountain Park	10/1/1982	Alignments of Elliot Rd. & 24th St.	918	770	0.84
68200	Guadalupe FRS	6/29/1989	1/4 mi. SSW of Baseline Rd. & I-10	843	738	0.88

Station No	Station Name	Data Begins:	Location	Number of Rainfall Events Observed	Number of Rainfall Events less than 0.5 inch	Ratio of rainfall events less than 0.5 inch
6800	Camelback Rd. @ 24th Ave.	10/8/2015	24th Ave. north of Camelback Road	52	44	0.85
67800	Laveen Basin	11/7/2006	Southern & 43rd Avenues	268	235	0.88
67500	ASU South	7/14/1995	1/4 mi. NNE of Broadway Rd. & Mill Ave.	597	502	0.84
67300	Salt River @ Priest Dr.	9/21/1995	Salt River bridge at Priest Dr.	554	476	0.86
6700	Maryland Ave. @ 27th Ave.	12/22/1994	27th Ave. 1/2 mi. N of Bethany Home Rd.	594	505	0.85
67000	Salt River @ 40th St.	3/22/1996	South side of Salt River @ 40th St.	491	432	0.88
66800	Roeser Rd. @ 23rd Ave.	10/1/2015	23rd Ave. @ Roeser Rd.	56	51	0.91
66700	Roeser Rd. @ 2nd St.	2/12/1991	1/2 mi. SSE of Broadway Rd. & Central Ave.	637	544	0.85
66500	Cesar Chavez Park	8/15/1990	1/2 mi. SW of 35th Ave. & Baseline Rd.	679	588	0.87
66200	Skunk Creek near New River	6/28/2001	Skunk Creek at Fig Springs Rd., 3.5 miles east of New River	527	414	0.79
66000	Cline Creek	8/1/1981	4 miles east of New River	1242	982	0.79
65900	Sonoran Wash	10/13/2015	1.75 miles east of Loop 303 @ I-17	67	60	0.90
65800	Skunk Creek at I-17	11/7/1989	I-17 at Jomax Rd.	769	626	0.81
65700	Skunk Creek @ Carefree Hwy.	8/18/2015	Carefree Hwy., 0.7 mi. E of I-17	65	51	0.78
65500	Fig Springs	11/14/2001	3.5 miles east of New River	530	413	0.78
65300	Upper Cline Creek	11/21/2001	8 miles east of New River	545	441	0.81
6500	City of Glendale	7/6/1989	Grand Ave. & 63rd Ave.	717	606	0.85
65000	Adobe Dam	10/25/1982	1/4 mi. South of Deer Valley Road & 43rd Avenue	922	744	0.81
64700	Skunk Tank Wash	3/2/2006	0.2 mi. S of 7th Ave. & Desert Hills Dr.	327	270	0.83
64200	Tat Momolikot Dam	1/29/1998	19 mi. SW of Casa Grande	493	445	0.90
64000	Greene Wash @ SR 84	3/16/1994	10 mi. W of SR 93 & SR 84	572	497	0.87
63800	Santa Cruz River @ SR 84	3/16/1994	3 mi. W of SR 93 on SR 84	594	526	0.89
63500	Saguaro Lake	1/24/2000	MCSO yard, NW corner of the lake	559	444	0.79
63300	Whitlow Ranch Dam	1/8/1998	5 mi. NE of Florence Junction	652	526	0.81
63000	Cooks Mesa	3/21/1984	10 miles east of Black Canyon City	1460	1119	0.77
62700	New River Fire	7/20/2005	5 miles northeast of New River	407	308	0.76

Station No	Station Name	Data Begins:	Location	Number of Rainfall Events Observed	Number of Rainfall Events less than 0.5 inch	Ratio of rainfall events less than 0.5 inch
62500	New River Landfill	4/29/1993	4 mi. ENE of New Waddell Dam	664	542	0.82
62300	Sunup Ranch	6/10/1981	1 mi. SSW of New River	1148	901	0.78
6200	Buckeye Rd. @ 75th Ave.	8/1/1996	1/4 mi. N of Buckeye Rd. & 75th Ave.	487	418	0.86
62000	New River Dam	5/31/1986	1/2 mi. NE of Jomax Rd. and 83rd Ave.	809	660	0.82
61700	New River @ Bell Rd.	4/4/1990	Bell Road at 83rd Ave.	714	598	0.84
61500	New River @ Glendale Ave.	3/21/1990	On Glendale 1/2 mile east of 99th Ave.	690	596	0.86
61200	Reata Pass Dam	8/26/1993	1/2 mi. S of Dynamite Blvd. & 112th St.	777	616	0.79
61000	Rawhide Wash	7/22/1999	1/3 mi. W of Pima Rd. on Dynamite Blvd.	542	427	0.79
60800	Pima Rd. @ Jomax Rd.	5/6/1993	1/8 mi. NW of Pima Rd. & Jomax Rd.	745	600	0.81
60500	Pinnacle Peak Vista	4/21/1998	1/2 mi. SSE of Deer Valley Rd. & Pima Rd.	553	466	0.84
60300	Pima Rd. @ Union Hills Dr.	10/22/1997	1/4 mi. W of Pima Rd. & Union Hills Dr.	582	495	0.85
6000	Maryvale Municipal Golf Course	8/17/1989	1/4 mi. N of Indian School Rd. & 59th Ave.	755	645	0.85
60000	Reata Pass Wash	5/15/2001	1.6 mi. E of Pima Rd. on Pinnacle Peak Rd.	477	395	0.83
59700	Aztec Park	2/9/1998	Near Thunderbird & Frank Lloyd Wright	553	462	0.84
59500	IBW @ Shea Blvd.	6/9/1998	Shea Blvd. @ 52nd St.	505	436	0.86
59200	Berneil Wash	7/30/1998	Doubletree & Invergordon	503	431	0.86
59000	Lake Margherite	11/25/1997	1/4 mi. W of Doubletree & Hayden Roads	575	492	0.86
58800	Lost Dog Wash	7/13/1990	1/2 mi. NNW of Shea Blvd. & 128th St.	797	660	0.83
58600	CAP Reach11 Dike # 2	7/19/2016	0.4 miles NW of Bell Rd. & 64th St.	37	33	0.89
58300	IBW @ Sweetwater Ave.	12/27/1990	1/2 mi. E of 32nd St. & Sweetwater Ave.	702	584	0.83
58000	Tatum Basin Inflow	6/3/1994	Shea Blvd. @ 40th St.	583	485	0.83
57700	Thunderbird Academy	1/1/1982	1/4 mi. ESE of Thunderbird and Scottsdale	1016	863	0.85
57500	Granite Reef Wash	6/26/2007	On McDowell Rd. just E of Granite Reef Rd.	263	227	0.86
56800	IBW Interceptor Channel	9/28/1983	1/4 mi. SW of Pima Rd. & Indian Bend Rd.	909	762	0.84
56500	IBW @ Indian School Rd.	11/26/1997	Indian School Rd. @ Hayden Rd.	500	421	0.84
56300	IBW @ Indian Bend Rd.	3/25/1992	On IBW just S of Indian School Rd.	731	596	0.82

Station No	Station Name	Data Begins:	Location	Number of Rainfall Events Observed	Number of Rainfall Events less than 0.5 inch	Ratio of rainfall events less than 0.5 inch
56000	Osborn Rd. @ 64th St.	10/22/1997	Osborn Rd. @ 64th St.	504	436	0.87
55700	IBW @ McKellips Rd.	7/15/1985	On IBW 1/4 mi. S of McKellips Rd.	828	679	0.82
55500	Upper Martinez Creek	2/26/2002	3.3 mi. NE of Congress	526	412	0.78
55200	Antelope Creek	7/9/2003	6.5 mi. NNW of Wickenburg	451	353	0.78
5500	Salt River @ 67th Ave.	4/23/1998	67th Ave. at Roeser St. N of Salt River	437	379	0.87
55000	Bucks Well	12/11/2002	5.5 mi. NW of Congress	483	377	0.78
54500	Wilhoit	9/24/1981	10 miles SSW of Prescott	1771	1454	0.82
54300	Hassayampa R. @ Wagoner Rd.	12/19/1983	6 mi. ESE of Kirkland Junction	1389	1141	0.82
54000	Minnehaha	6/16/1981	11 miles E of Wagoner	1791	1402	0.78
53700	O'Brien Gulch	9/1/1981	11 miles NE of Wickenburg	1335	1047	0.78
53500	Hassayampa River @ Box Canyon	11/17/1983	6 miles N of Wickenburg	1079	905	0.84
53200	Burton Tank	3/19/2002	3 miles SSW of Congress	496	386	0.78
53000	Casandro Dam	8/15/1996	1.1 mi. W of the US60 / US93 junction	600	479	0.80
52800	Wickenburg Airport	8/3/1994	4.5 mi. W of the US60 / US93 junction	664	529	0.80
52500	Powder House Wash	5/18/1995	1/2 mi. NE of Constellation Rd. & US 60	616	502	0.81
52300	Constellation Road	8/3/1994	1.4 mi. NE of the US60 / US93 junction	682	555	0.81
52000	Casandro Wash	7/12/1994	2 mi. W of the US60 / US93 junction	689	546	0.79
51700	Flying E Wash	7/12/1994	3 mi. W of the US60 / US93 junction	686	546	0.80
51500	Flying E Tank	5/9/1995	6.3 mi. WSW of the US89 / US93 junction	648	518	0.80
51200	Hartman Wash	7/6/1994	6.3 mi. W of the US60 / US93 junction	701	564	0.80
51000	Black Mountain	7/6/1994	9 mi. W of the US60 / US93 junction	690	561	0.81
50800	Sols Wash near Matthe	8/4/1995	2 mile N of Wickenburg Airport	648	535	0.83
50500	Black Hill	6/15/1995	2.3 mi. WSW of the US93 / US89 junction	666	533	0.80
50300	Sols Tank	7/25/1995	6.3 mi. WNW of the US93/US89 junction	703	555	0.79
5000	Thomas Rd. @ 48th St.	1/30/1991	Thomas Rd. @ 48th St.	722	615	0.85
50000	Sols Wash Tributary @ US 93	5/2/1995	3.2 mi. NW of the US 93 / US 89 junction	694	556	0.80

Station No	Station Name	Data Begins:	Location	Number of Rainfall Events Observed	Number of Rainfall Events less than 0.5 inch	Ratio of rainfall events less than 0.5 inch
49700	Congress	6/16/1994	Junction of US 89 and SR 71	761	604	0.79
49500	Martinez Creek	11/23/1994	1 mi. E of the US93/US89 junction	676	560	0.83
49200	Mid-Martinez Creek	4/27/1995	4.5 mi. SE of Congress	732	584	0.80
49000	Stanton	6/16/1994	6.5 mi. E of Congress	871	696	0.80
48800	Buckeye FRS # 3	11/23/1992	1/4 mi. NE of I-10 & Watson Rd.	547	461	0.84
48500	Daggs Wash	11/8/2007	9.5 miles SW of Circle City	254	208	0.82
48300	Sun Valley Park @ Northern Ave.	8/2/2005	Northern Ave. @ Sun Valley Parkway	266	224	0.84
47700	Sols Wash @ SR 71	9/24/1981	1 mi. west of SR 71 & US 93	1178	925	0.79
47500	Box Wash	3/11/2003	9 mile SW of Wickenburg	386	302	0.78
4700	Old Crosscut Canal @ McDowell Rd.	7/27/1994	S of McDowell Rd. @ SR 143	601	518	0.86
47000	Vulture Mine Road	10/14/1981	3 mi. SW of the US60/US93 intersection	1094	893	0.82
46800	Twin Peaks	3/27/2003	6 miles SW of Wickenburg	368	287	0.78
46500	Sunnycove FRS	8/11/1986	1 mi. SW of the US 60/93 junction	865	698	0.81
46300	Belmont Mountains	12/16/2002	4.8 miles SW of the Wickenburg / Aguila Roads intersection	368	297	0.81
46000	Sunset FRS	5/11/1989	3/4 mi. WSW of the US 60/93 intersection	782	636	0.81
45700	Hassayampa River @ US 60	3/14/1994	Old US 60 bridge over Hassayampa R.	702	569	0.81
45200	Morristown	5/13/1992	US 60/93 10 mi. SE of Wickenburg	729	583	0.80
4500	Papago Park	8/15/1990	1/4 mi. N of McDowell Rd. & 52nd St.	738	646	0.88
45000	Jackrabbit Wash	9/14/1982	Intersection of Wickengurg and Aguila Roads	919	763	0.83
44800	Hassayampa Landfill	4/15/1993	2 mi. NW of Hassayampa	484	405	0.84
44500	Buckeye FRS #2	11/11/1992	Alignments of Yuma and Miller Roads	570	478	0.84
44000	Buckeye FRS #1	7/26/1983	Hassayampa R. @ I-10	789	664	0.84
43700	Dead Horse Wash	11/1/2000	Near Aguila Rd., 14 mi. SE of Aguila	419	348	0.83
4300	Phoenix Zoo Dam # 3	4/25/2016	1/2 mile NE of Galvin Pkwy & Van Buren St.	34	30	0.88
43000	Maricopa Mountains	4/21/2005	11 mi. ENE of Gila Bend on SR 238	255	209	0.82
42800	Rainbow Wash	11/6/2000	9 mi. S of Buckeye on SR 85	339	285	0.84

APPENDIX

Station No	Station Name	Data Begins:	Location	Number of Rainfall Events Observed	Number of Rainfall Events less than 0.5 inch	Ratio of rainfall events less than 0.5 inch
42500	Gila Bend Landfill	4/7/1993	3 mi. N of US 80 & I-8	494	428	0.87
42300	Magma FRS	10/27/1988	7 mi. NNW of Florence	835	711	0.85
4200	Perry Park	8/22/1990	1/8 mi. S of Thomas Rd. & 32nd St.	773	665	0.86
42000	Gila River @ Olberg	4/12/1995	3 mi. ENE of Sacaton	586	523	0.89
41700	Gila River @ Maricopa Rd.	4/6/1995	Maricopa Rd. & Gila River bridge	524	455	0.87
41500	Gila Bend Mountains	6/1/1988	16 mi. NW of Painted Rock Dam	596	517	0.87
41200	4th of July Wash	3/14/2002	21 mi. W of Old US80 on Agua Caliente Rd.	312	254	0.81
41000	Copper Wash	2/20/2001	15 mi. N of Agua Caliente	304	246	0.81
40500	Bender Wash	1/12/1982	9 mi. E of Gila Bend on I-8	875	755	0.86
40300	Sand Tank Wash	7/21/1983	9 mi. SSE of Gila Bend	831	704	0.85
4000	Thomas Rd. @ 16th St.	1/17/1991	Thomas Rd. @ 16th St.	701	601	0.86
40000	Sand Tank Wash @ I-8	6/28/2001	I-8 bridge south of Gila Bend	316	271	0.86
39700	Salt River Landfill	1/30/1998	1/4 mi. N of Beeline Hwy. at Gilbert Rd.	529	433	0.82
39500	Salt River @ Val Vista Dr.	4/13/2011	1/2 mi. W of Val Vista at the Salt R.	161	134	0.83
39200	Weekes Wash @ Baseline Rd.	5/27/2008	Baseline Rd. @ Royal Palm Ln.	286	240	0.84
39000	Kings Ranch	9/13/1981	7 mi. ESE of Apache Junction	1139	926	0.81
38800	Bulldog Canyon	7/11/2007	2 mi. NW of McDowell & Tomahawk Roads	354	273	0.77
38500	Florence Junction	8/1/1982	4.5 mi. NW of Florence Junction	1137	914	0.80
38300	Wolverine Pass	7/12/2007	1/4 mi. N of McDowell & Tomahawk	330	265	0.80
3800	Grand Ave. @ 27th Ave.	10/11/1996	Near 28th Ave. & Grand Ave.	496	425	0.86
38000	Queen Cr. @ CAP Canal	1/14/1999	Queen Creek at CAP Canal	484	394	0.81
37700	Queen Cr. @ Rittenhouse Rd.	9/14/1993	1/3 mi. SE of Signal Butte & Chandler Heights	629	512	0.81
37500	Powerline Floodway	2/13/2008	Alignments of Ray & Ellsworth Roads	264	229	0.87
37300	Carney Springs	8/16/2016	6.2 miles NE of Peralta Rd. @ US 60	39	32	0.82
37200	Rittenhouse FRS	9/27/1988	Alignments of Goldfield & Germann Roads	819	693	0.85
37100	Peralta Road	8/16/2016	3.4 miles NE of Peralta Rd. @ US 60	42	33	0.79

Station No	Station Name	Data Begins:	Location	Number of Rainfall Events Observed	Number of Rainfall Events less than 0.5 inch	Ratio of rainfall events less than 0.5 inch
37000	Vineyard FRS	11/2/1983	Alignments of Tomahawk & Williams Field	992	827	0.83
36900	US 60 @ Gold Canyon	5/11/2016	US 60 at Superstition Mountain Dr.	43	33	0.77
36500	Apache Trail	4/14/1993	1/3 mi. NE of Broadway & Idaho Roads	712	581	0.82
36300	Sonoqui Wash near Hawes Rd.	4/23/1993	1/2 mi. SW of Ocotillo & Ellsworth Roads	580	481	0.83
36000	Queen Creek Road	5/1/1982	1/4 mi. NE of Queen Creek Rd. & Ellsworth	998	839	0.84
35700	Guadalupe Channel	8/7/1998	1/4 mi. E of Power Rd. and Guadalupe Rd.	510	433	0.85
35200	E. Maricopa Floodway @ Arizona Ave.	5/10/1989	SR 587 bridge 3 miles S of Riggs Rd.	745	640	0.86
3500	Jackson St. @ 7th Ave.	1/29/1991	County Building, 7th Ave. & Jackson St.	642	541	0.84
35000	Elliot Rd. @ Hawes Rd.	6/26/2001	NE corner of Elliot Rd. at Hawes Rd.	412	343	0.83
34800	EMF @ Queen Creek Rd.	1/18/1989	1/3 mi. W of Queen Creek Rd. and Higley	713	622	0.87
34500	Williams Field Road	7/3/2001	1/4 mi. N of Williams Field Rd. & Meridian	446	376	0.84
34300	E. Maricopa Floodway @ Broadway Rd.	8/10/1989	1/2 mi. SSE of Broadway & Higley Roads	741	621	0.84
34000	Falcon Field	10/1/1995	1/4 mi. NE of McKellips & Greenfield Rds.	588	504	0.86
33700	EMF below Powerline Floodway	4/15/2014	1/4 mi. SE of Ray Rd. & Power Rd.	93	82	0.88
33500	McDowell Rd. @ Meridian Rd.	4/23/2006	125 yards E of McDowell & Meridian Rds.	359	293	0.82
33200	McDowell Rd. @ Hawes Rd.	4/13/2006	100 yards W of McDowell & Hawes Roads	333	266	0.80
3300	Durango Complex	6/23/1980	27th Ave. & Durango St.	966	815	0.84
33000	Crossroads Park	12/18/1995	1/2 mi. NW of Ray Rd. & Greenfield Rd.	552	483	0.88
32800	Freestone Basin	12/19/1995	1/2 mi. SSE of Guadalupe & Lindsay Roads	565	495	0.88
32500	Chandler Airport	1/26/2006	1/4 mi. south of Queen Creek & McQueen	297	257	0.87
32300	Mesa Tower	7/19/1989	1/4 mi. NW of McQueen Rd. & Baseline Rd.	763	651	0.85
32000	Chandler Blvd. @ Arizona Ave.	7/25/1996	1/4 mi. W of Chandler Blvd. and Arizona Ave.	563	485	0.86
31700	Carriage Lane Park	3/26/1991	1/2 mi. S of Price & Guadalupe Roads	686	591	0.86
31500	Price Drain @ Loop 202	2/13/2001	Loop 202 at Loop 101	446	375	0.84
31200	Mountain View Park	3/21/1991	1/2 mi. N of University Dr. & Lindsay Rd.	708	589	0.83
31000	Fitch Park	3/27/1991	1/2 mi. N of University Dr. & Center St.	704	585	0.83

APPENDIX

Station No	Station Name	Data Begins:	Location	Number of Rainfall Events Observed	Number of Rainfall Events less than 0.5 inch	Ratio of rainfall events less than 0.5 inch
30500	Joshua Tree	3/5/2002	4.5 mi. W of the US93 / SR71 junction	463	357	0.77
30300	Wood Tank	11/20/2002	8 miles NE of Aguila	417	338	0.81
3000	GateWay Community College	12/16/2003	40th St. & Van Buren St.	346	294	0.85
30000	Ritter Dam	11/21/2002	9 miles NE of Aguila	414	326	0.79
29700	Centennial Divide	8/21/2001	7 mi. W of the US60 / US93 junction	454	368	0.81
29500	Smith Peak	5/1/1980	13 mi. NW of Aguila	1186	996	0.84
29400	Alamo Road	11/19/2015	8 miles north of Wenden	54	47	0.87
29200	Centennial Wash	11/19/1981	19 miles W of Wickenburg	1020	855	0.84
29000	Centennial Wash near Aguila	6/5/2001	5 mi. NNE of the US 60/SR 71 junction	446	361	0.81
28800	Gladden	8/27/1982	US 60 at Gladden, 34 mi. W of Wickenburg	922	781	0.85
28500	Outlaw Hill	5/13/2002	S of US 60; 14 mi. E of Aguila	449	356	0.79
28300	Aguila VFD	9/19/2001	1/4 mi. SE of US 60 & Eagle Eye Rd.	417	353	0.85
28000	Narrows Damsite	9/1/1994	5 miles SE of Salome	489	409	0.84
27700	Upper Grass Wash	11/1/2002	7 miles east of Aguila	398	322	0.81
27500	Centennial Wash @ Wenden	9/2/1998	5.5 mi. NE of Salome on US 60 bridge	442	372	0.84
27000	Tiger Wash	9/15/1999	10 mi. N of Eagle Eye Rd. @ Salome Hwy.	424	344	0.81
26800	Tiger Wash Fan	9/21/1994	1 mi. W of Eagle Eye Rd. and 4 mi. N of Salome Highway	503	421	0.84
26500	Four Mile Wash	7/5/2001	Alignments of 371st Ave. & Glendale Ave.	360	302	0.84
26300	Upper Tiger Wash	11/1/1981	11 mi. S of Aguila off Eagle Eye Rd.	972	789	0.81
26000	Harquahala FRS	9/15/1993	10 mi. WNW of Tonopah	445	376	0.84
25700	Centennial Levee	3/7/1984	2 mi. S of I-10 & 4 mi. E of the western County boundary	696	582	0.84
25500	Winters Wash	7/11/2000	1 mi. N of Indian School & 403rd Ave.	385	321	0.83
25200	Saddleback FRS	12/16/1988	7 miles WSW of Tonopah	541	465	0.86
25000	Delaney Wash	12/20/1999	3 miles SSW of Tonopah	377	312	0.83
24700	Centennial Railroad	2/9/1990	8 mi. NW of Old US 80 at the Gila River	649	561	0.86
24500	Webb Mountain	5/22/2002	4 mi. W of Agua Caliente Rd. & Old US 80	335	270	0.81

Station No	Station Name	Data Begins:	Location	Number of Rainfall Events Observed	Number of Rainfall Events less than 0.5 inch	Ratio of rainfall events less than 0.5 inch
24300	Baseline Rd. @ 547th Ave.	5/24/2000	SW corner of Baseline and 547th Ave.	368	308	0.84
24000	Buckeye Rd. @ 547th Ave.	6/13/2000	Buckeye Rd. at 547th Ave.	341	279	0.82
23700	Cruff Wash	5/14/2002	6 mi. W of Agua Caliente Rd. @ Old US 80	332	267	0.80
23500	Eagle Eye Road @ CAP	6/17/2003	1.5 mi. S of Salome Hwy on Eagle Eye Rd.	287	243	0.85
23200	G&F Woolsey Peak	6/25/2003	8 miles SW of Gillespie Dam	309	252	0.82
23000	Sugarloaf Mountain	5/27/2004	16 mi. NW of Tonopah	328	271	0.83
22800	Centennial Trib. @ Dobbins Rd.	10/1/2012	7.5 mi. WSW of Palo Verde NGS	111	99	0.89
22000	New River Mesa	3/3/2009	11 mi. N of Cave Creek	328	256	0.78
21800	Seven Springs Wash	3/12/2002	11 mi. NE of Cave Creek	660	504	0.76
21500	Seven Springs	11/12/1981	15 mi. NNE of Cave Creek	1682	1336	0.79
21000	Carefree Ranch	7/15/1985	2.5 mi. NE of SkyRanch Airport	1108	883	0.80
20700	Cave Creek @ Spur Cross Rd.	6/16/1993	3.5 mi. N of Cave Creek	825	655	0.79
20600	Galloway Wash @ Galloway Rd.	8/16/2016	Galloway Rd. 1/4 mile N of Cave Creek Rd.	43	36	0.84
20200	Cave Creek Landfill	4/23/1993	1/2 mi. E of Carefree Hwy. & 40th St.	672	545	0.81
2000	Mt. Ord	10/28/1982	4 mi. E of Sunflower (and lots higher!)	1893	1574	0.83
20000	Stagecoach Wash	6/13/2001	1/2 mi. S of Cave Creek Rd. & Pima Rd.	526	416	0.79
19500	Cave Buttes Dam	1/25/1984	1/4 mi. N of Happy Valley Rd. & 16th St.	820	717	0.87
19300	Desert Hills Wash	3/2/2006	Joy Ranch Rd. at 16th St.	341	278	0.82
1900	Thompson Peak	7/27/1989	120th St. and Bell Rd. alignments	874	741	0.85
19000	Cave Creek	5/29/2003	1 mi. W of Cave Creek Town Hall	479	382	0.80
18700	Desert Mountain School	7/19/2006	1/4 mi. SE of Cloud Rd. & 7th Ave.	305	252	0.83
18500	Buckeye Rd. @ SR 85	9/20/2000	1/4 mi. E of Buckeye Rd. @ SR 85	346	304	0.88
18200	I-10 @ 355th Ave.	9/7/2001	3 mi. WNW of Hassayampa R. @ I-10	348	291	0.84
1800	White Tank Peak	4/1/1981	13 mi. N of Buckeye	1025	848	0.83
17800	Dewey	11/1/1982	5 mi. E of Dewey off Orme Ranch Rd.	1574	1313	0.83

APPENDIX

Station No	Station Name	Data Begins:	Location	Number of Rainfall Events Observed	Number of Rainfall Events less than 0.5 inch	Ratio of rainfall events less than 0.5 inch
17500	I-17 @ SR 169	11/11/1987	West of Interstate 17 at State Route 169 (Cherry Rd.)	1356	1122	0.83
17300	Arizona Hunt Club	4/1/1981	5 mi. NNW of Cordes Junction	1504	1227	0.82
1700	Towers Mountain	5/1/1992	3 miles NW of Crown King	1630	1312	0.80
17000	Horner Mountain Ranch	4/1/1981	11 mi. ENE of Cordes Junction	1586	1303	0.82
16700	Horseshoe Ranch	5/1/1981	10 mi. SE of Cordes Junction	1440	1140	0.79
16500	Sunset Point	7/11/1981	Sunset Point Rest Area on I-17, 10 mi. N of Black Canyon City	1474	1165	0.79
1600	Yarnell Hill	7/13/1981	1 mile E of Yarnell	1547	1206	0.78
16000	Horsethief Basin	11/24/1986	At HB Lookout, 6 mi. SE of Crown King	1747	1430	0.82
15800	Columbia Hill	7/27/1981	5 mi. NNW of Castle Hot Springs	1292	970	0.75
15500	Garfias Mountain Ranch	4/14/1981	6 mi. WSW of Castle Hot Springs	1313	1012	0.77
15300	Lake Pleasant North	4/24/2001	North end of Lake Pleasant	454	364	0.80
1500	Harquahala Mountain	2/10/1994	36 miles WSW of Wickenburg	789	623	0.79
15000	Lake Pleasant	11/13/2008	South end of Lake Pleasant	254	207	0.81
14700	Agua Fria R. @ Grand Ave.	4/27/1994	Grand Ave. bridge at Agua Fria River	576	497	0.86
14500	El Mirage Drain	2/16/2006	½ mile S of Pinnacle Peak and El Mirage	279	243	0.87
14200	Deer Valley Airport	1/23/1991	1/2 mi. N of Deer Valley Rd. and 7th Ave.	777	633	0.81
13800	ACDC @ 67th Ave.	6/7/1990	67th Ave. bridge at Arizona Canal	731	605	0.83
13500	Phoenix West Park	11/29/2001	Peoria Ave. at 7th Ave.	390	330	0.85
13300	Phoenix Basin # 7	10/17/1996	1/4 mi. SW of Thunderbird Rd. & 7th St.	530	445	0.84
1300	Mt. Oatman	4/1/1981	8 mi. WSW of Painted Rock Dam	804	674	0.84
12700	Phoenix Dam # 99	7/7/2009	32nd St. & SR 51	198	170	0.86
12500	Greenway @ 32nd Ave.	1/31/1991	1/4 mi. E of Greenway Rd. & 35th Ave.	702	587	0.84
1200	Humboldt Mountain	7/14/1981	13 mi. NE of Cave Creek	1585	1325	0.84
12000	ACDC @ Cave Creek	3/11/1997	Mountain View Rd. near 23rd Ave.	539	467	0.87
11800	Cave Creek @ Cactus Rd.	7/13/1991	1/4 mi. ENE of I-17 & Cactus Rd.	713	606	0.85

Station No	Station Name	Data Begins:	Location	Number of Rainfall Events Observed	Number of Rainfall Events less than 0.5 inch	Ratio of rainfall events less than 0.5 inch
11500	Phoenix Basin # 3	12/18/2001	Cave Creek Rd. @ 16th St.	376	317	0.84
11300	ACDC @ 43rd Ave.	11/14/1990	1/4 mi. NW of Peoria & 43rd Aves.	735	620	0.84
11000	10th St. Wash Basin # 1	10/23/1996	1/4 mi. SW of Peoria Ave. & Cave Creek Rd.	507	436	0.86
10500	ACDC @ 14th St.	2/9/1994	1/2 mi. N of Glendale Ave. & 14th St.	592	493	0.83
1000	Mt. Union	8/16/1982	10 miles SSE of Prescott	2519	2052	0.81
10000	ACDC @ 36th St.	2/24/1994	1/2 mi. N of 36th St. & Camelback Rd.	615	528	0.86

APPENDIX B: RAINFALL TABLES

Underground Storage Volume and Percolation Rates for Green Infrastructure
4-foot wide x 10-foot long storage area.

Width (ft)	Depth of reservoir layer (ft)	Length (ft)	Design Porosity (% Voids)	Infiltration Rate		cf/hr/sf	cf/hr	hrs	LID Storage Volume for Standard Design (cf)	Note
				i						
				(in/hr)	(in/min)					
4	2	10	0.25	0.02	0.00033	0.002	0.07	300.00	20.00	Must be connected to another drainage facility
4	2	10	0.25	0.04	0.00067	0.003	0.13	150.00	20.00	Must be connected to another drainage facility
4	2	10	0.25	0.06	0.00100	0.005	0.20	100.00	20.00	Must be connected to another drainage facility
4	2	10	0.25	0.08	0.00133	0.007	0.27	75.00	20.00	Must be connected to another drainage facility
4	2	10	0.25	0.10	0.00167	0.008	0.33	60.00	20.00	Must be connected to another drainage facility
4	2	10	0.25	0.15	0.00250	0.013	0.50	40.00	20.00	Must be connected to another drainage facility
4	2	10	0.25	0.20	0.00333	0.017	0.67	30.00	20.00	
4	2	10	0.25	0.25	0.00417	0.021	0.83	24.00	20.00	
4	2	10	0.25	0.30	0.00500	0.025	1.00	20.00	20.00	
4	2	10	0.25	0.40	0.00667	0.033	1.33	15.00	20.00	
4	2	10	0.25	0.50	0.00833	0.042	1.67	12.00	20.00	
4	2	10	0.25	0.60	0.01000	0.050	2.00	10.00	20.00	
4	2	10	0.25	0.70	0.01167	0.058	2.33	8.57	20.00	
4	2	10	0.25	0.80	0.01333	0.067	2.67	7.50	20.00	
4	2	10	0.25	1.00	0.01667	0.083	3.33	6.00	20.00	
4	2	10	0.25	1.50	0.02500	0.125	5.00	4.00	20.00	
4	2	10	0.25	2.00	0.03333	0.167	6.67	3.00	20.00	
4	2	10	0.25	2.50	0.04167	0.208	8.33	2.40	20.00	
4	2	10	0.25	3.00	0.05000	0.250	10.00	2.00	20.00	

**Underground Storage Volume and Percolation Rates for Green Infrastructure
4-foot wide x 10-foot long storage area.**

Width (ft)	Depth of reservoir layer (ft)	Length (ft)	Design Porosity (% Voids)	Infiltration Rate		cf/hr/sf	cf/hr	hrs	LID Storage Volume for Standard Design (cf)	Note
				i						
				(in/hr)	(in/min)					
4	4	10	0.25	0.02	0.00033	0.002	0.07	600.00	40.00	Must be connected to another drainage facility
4	4	10	0.25	0.04	0.00067	0.003	0.13	300.00	40.00	Must be connected to another drainage facility
4	4	10	0.25	0.06	0.00100	0.005	0.20	200.00	40.00	Must be connected to another drainage facility
4	4	10	0.25	0.08	0.00133	0.007	0.27	150.00	40.00	Must be connected to another drainage facility
4	4	10	0.25	0.10	0.00167	0.008	0.33	120.00	40.00	Must be connected to another drainage facility
4	4	10	0.25	0.15	0.00250	0.013	0.50	80.00	40.00	Must be connected to another drainage facility
4	4	10	0.25	0.20	0.00333	0.017	0.67	60.00	40.00	Must be connected to another drainage facility
4	4	10	0.25	0.25	0.00417	0.021	0.83	48.00	40.00	Must be connected to another drainage facility
4	4	10	0.25	0.30	0.00500	0.025	1.00	40.00	40.00	Must be connected to another drainage facility
4	4	10	0.25	0.40	0.00667	0.033	1.33	30.00	40.00	
4	4	10	0.25	0.50	0.00833	0.042	1.67	24.00	40.00	
4	4	10	0.25	0.60	0.01000	0.050	2.00	20.00	40.00	
4	4	10	0.25	0.70	0.01167	0.058	2.33	17.14	40.00	
4	4	10	0.25	0.80	0.01333	0.067	2.67	15.00	40.00	
4	4	10	0.25	1.00	0.01667	0.083	3.33	12.00	40.00	
4	4	10	0.25	1.50	0.02500	0.125	5.00	8.00	40.00	
4	4	10	0.25	2.00	0.03333	0.167	6.67	6.00	40.00	
4	4	10	0.25	2.50	0.04167	0.208	8.33	4.80	40.00	
4	4	10	0.25	3.00	0.05000	0.250	10.00	4.00	40.00	

Underground Storage Volume and Percolation Rates for Green Infrastructure
4-foot wide x 10-foot long storage area.

Width (ft)	Depth of reservoir layer (ft)	Length (ft)	Design Porosity (% Voids)	Infiltration Rate		cf/hr/sf	cf/hr	hrs	LID Storage Volume for Standard Design (cf)	Note
				i						
				(in/hr)	(in/min)					
4	6	10	0.25	0.02	0.00033	0.002	0.07	900.00	60.00	Must be connected to another drainage facility
4	6	10	0.25	0.04	0.00067	0.003	0.13	450.00	60.00	Must be connected to another drainage facility
4	6	10	0.25	0.06	0.00100	0.005	0.20	300.00	60.00	Must be connected to another drainage facility
4	6	10	0.25	0.08	0.00133	0.007	0.27	225.00	60.00	Must be connected to another drainage facility
4	6	10	0.25	0.10	0.00167	0.008	0.33	180.00	60.00	Must be connected to another drainage facility
4	6	10	0.25	0.15	0.00250	0.013	0.50	120.00	60.00	Must be connected to another drainage facility
4	6	10	0.25	0.20	0.00333	0.017	0.67	90.00	60.00	Must be connected to another drainage facility
4	6	10	0.25	0.25	0.00417	0.021	0.83	72.00	60.00	Must be connected to another drainage facility
4	6	10	0.25	0.30	0.00500	0.025	1.00	60.00	60.00	Must be connected to another drainage facility
4	6	10	0.25	0.40	0.00667	0.033	1.33	45.00	60.00	Must be connected to another drainage facility
4	6	10	0.25	0.50	0.00833	0.042	1.67	36.00	60.00	
4	6	10	0.25	0.60	0.01000	0.050	2.00	30.00	60.00	
4	6	10	0.25	0.70	0.01167	0.058	2.33	25.71	60.00	
4	6	10	0.25	0.80	0.01333	0.067	2.67	22.50	60.00	
4	6	10	0.25	1.00	0.01667	0.083	3.33	18.00	60.00	
4	6	10	0.25	1.50	0.02500	0.125	5.00	12.00	60.00	
4	6	10	0.25	2.00	0.03333	0.167	6.67	9.00	60.00	
4	6	10	0.25	2.50	0.04167	0.208	8.33	7.20	60.00	
4	6	10	0.25	3.00	0.05000	0.250	10.00	6.00	60.00	

**Underground Storage Volume and Percolation Rates for Green Infrastructure
4-foot wide x 10-foot long storage area.**

Width (ft)	Depth of reservoir layer (ft)	Length (ft)	Design Porosity (% Voids)	Infiltration Rate		cf/hr/sf	cf/hr	hrs	LID Storage Volume for Standard Design (cf)	Note
				i						
				(in/hr)	(in/min)					
4	8	10	0.25	0.02	0.00033	0.002	0.07	1200.00	80.00	Must be connected to another drainage facility
4	8	10	0.25	0.04	0.00067	0.003	0.13	600.00	80.00	Must be connected to another drainage facility
4	8	10	0.25	0.06	0.00100	0.005	0.20	400.00	80.00	Must be connected to another drainage facility
4	8	10	0.25	0.08	0.00133	0.007	0.27	300.00	80.00	Must be connected to another drainage facility
4	8	10	0.25	0.10	0.00167	0.008	0.33	240.00	80.00	Must be connected to another drainage facility
4	8	10	0.25	0.15	0.00250	0.013	0.50	160.00	80.00	Must be connected to another drainage facility
4	8	10	0.25	0.20	0.00333	0.017	0.67	120.00	80.00	Must be connected to another drainage facility
4	8	10	0.25	0.25	0.00417	0.021	0.83	96.00	80.00	Must be connected to another drainage facility
4	8	10	0.25	0.30	0.00500	0.025	1.00	80.00	80.00	Must be connected to another drainage facility
4	8	10	0.25	0.40	0.00667	0.033	1.33	60.00	80.00	Must be connected to another drainage facility
4	8	10	0.25	0.50	0.00833	0.042	1.67	48.00	80.00	Must be connected to another drainage facility
4	8	10	0.25	0.60	0.01000	0.050	2.00	40.00	80.00	Must be connected to another drainage facility
4	8	10	0.25	0.70	0.01167	0.058	2.33	34.29	80.00	
4	8	10	0.25	0.80	0.01333	0.067	2.67	30.00	80.00	
4	8	10	0.25	1.00	0.01667	0.083	3.33	24.00	80.00	
4	8	10	0.25	1.50	0.02500	0.125	5.00	16.00	80.00	
4	8	10	0.25	2.00	0.03333	0.167	6.67	12.00	80.00	
4	8	10	0.25	2.50	0.04167	0.208	8.33	9.60	80.00	
4	8	10	0.25	3.00	0.05000	0.250	10.00	8.00	80.00	

Underground Storage Volume and Percolation Rates for Green Infrastructure
5-foot wide x 10-foot long storage area.

Width (ft)	Depth of reservoir layer (ft)	Length (ft)	Design Porosity (% Voids)	Infiltration Rate		cf/hr/sf	cf/hr	hrs	LID Storage Volume for Standard Design (cf)	Note
				i						
				(in/hr)	(in/min)					
5	2	10	0.25	0.02	0.00033	0.002	0.08	300.00	25.00	Must be connected to another drainage facility
5	2	10	0.25	0.04	0.00067	0.003	0.17	150.00	25.00	Must be connected to another drainage facility
5	2	10	0.25	0.06	0.00100	0.005	0.25	100.00	25.00	Must be connected to another drainage facility
5	2	10	0.25	0.08	0.00133	0.007	0.33	75.00	25.00	Must be connected to another drainage facility
5	2	10	0.25	0.10	0.00167	0.008	0.42	60.00	25.00	Must be connected to another drainage facility
5	2	10	0.25	0.15	0.00250	0.013	0.63	40.00	25.00	Must be connected to another drainage facility
5	2	10	0.25	0.20	0.00333	0.017	0.83	30.00	25.00	
5	2	10	0.25	0.25	0.00417	0.021	1.04	24.00	25.00	
5	2	10	0.25	0.30	0.00500	0.025	1.25	20.00	25.00	
5	2	10	0.25	0.40	0.00667	0.033	1.67	15.00	25.00	
5	2	10	0.25	0.50	0.00833	0.042	2.08	12.00	25.00	
5	2	10	0.25	0.60	0.01000	0.050	2.50	10.00	25.00	
5	2	10	0.25	0.70	0.01167	0.058	2.92	8.57	25.00	
5	2	10	0.25	0.80	0.01333	0.067	3.33	7.50	25.00	
5	2	10	0.25	1.00	0.01667	0.083	4.17	6.00	25.00	
5	2	10	0.25	1.50	0.02500	0.125	6.25	4.00	25.00	
5	2	10	0.25	2.00	0.03333	0.167	8.33	3.00	25.00	
5	2	10	0.25	2.50	0.04167	0.208	10.42	2.40	25.00	
4	8	10	0.25	3.00	0.05000	0.250	10.00	8.00	80.00	

**Underground Storage Volume and Percolation Rates for Green Infrastructure
5-foot wide x 10-foot long storage area.**

Width (ft)	Depth of reservoir layer (ft)	Length (ft)	Design Porosity (% Voids)	Infiltration Rate		cf/hr/sf	cf/hr	hrs	LID Storage Volume for Standard Design (cf)	Note
				i						
				(in/hr)	(in/min)					
5	4	10	0.25	0.02	0.00033	0.002	0.08	600.00	50.00	Must be connected to another drainage facility
5	4	10	0.25	0.04	0.00067	0.003	0.17	300.00	50.00	Must be connected to another drainage facility
5	4	10	0.25	0.06	0.00100	0.005	0.25	200.00	50.00	Must be connected to another drainage facility
5	4	10	0.25	0.08	0.00133	0.007	0.33	150.00	50.00	Must be connected to another drainage facility
5	4	10	0.25	0.10	0.00167	0.008	0.42	120.00	50.00	Must be connected to another drainage facility
5	4	10	0.25	0.15	0.00250	0.013	0.63	80.00	50.00	Must be connected to another drainage facility
5	4	10	0.25	0.20	0.00333	0.017	0.83	60.00	50.00	Must be connected to another drainage facility
5	4	10	0.25	0.25	0.00417	0.021	1.04	48.00	50.00	Must be connected to another drainage facility
5	4	10	0.25	0.30	0.00500	0.025	1.25	40.00	50.00	Must be connected to another drainage facility
5	4	10	0.25	0.40	0.00667	0.033	1.67	30.00	50.00	
5	4	10	0.25	0.50	0.00833	0.042	2.08	24.00	50.00	
5	4	10	0.25	0.60	0.01000	0.050	2.50	20.00	50.00	
5	4	10	0.25	0.70	0.01167	0.058	2.92	17.14	50.00	
5	4	10	0.25	0.80	0.01333	0.067	3.33	15.00	50.00	
5	4	10	0.25	1.00	0.01667	0.083	4.17	12.00	50.00	
5	4	10	0.25	1.50	0.02500	0.125	6.25	8.00	50.00	
5	4	10	0.25	2.00	0.03333	0.167	8.33	6.00	50.00	
5	4	10	0.25	2.50	0.04167	0.208	10.42	4.80	50.00	
5	4	10	0.25	3.00	0.05000	0.250	12.50	4.00	50.00	

Underground Storage Volume and Percolation Rates for Green Infrastructure
5-foot wide x 10-foot long storage area.

Width (ft)	Depth of reservoir layer (ft)	Length (ft)	Design Porosity (% Voids)	Infiltration Rate		cf/hr/sf	cf/hr	hrs	LID Storage Volume for Standard Design (cf)	Note
				i						
				(in/hr)	(in/min)					
5	6	10	0.25	0.02	0.00033	0.002	0.08	900.00	75.00	Must be connected to another drainage facility
5	6	10	0.25	0.04	0.00067	0.003	0.17	450.00	75.00	Must be connected to another drainage facility
5	6	10	0.25	0.06	0.00100	0.005	0.25	300.00	75.00	Must be connected to another drainage facility
5	6	10	0.25	0.08	0.00133	0.007	0.33	225.00	75.00	Must be connected to another drainage facility
5	6	10	0.25	0.10	0.00167	0.008	0.42	180.00	75.00	Must be connected to another drainage facility
5	6	10	0.25	0.15	0.00250	0.013	0.63	120.00	75.00	Must be connected to another drainage facility
5	6	10	0.25	0.20	0.00333	0.017	0.83	90.00	75.00	Must be connected to another drainage facility
5	6	10	0.25	0.25	0.00417	0.021	1.04	72.00	75.00	Must be connected to another drainage facility
5	6	10	0.25	0.30	0.00500	0.025	1.25	60.00	75.00	Must be connected to another drainage facility
5	6	10	0.25	0.40	0.00667	0.033	1.67	45.00	75.00	Must be connected to another drainage facility
5	6	10	0.25	0.50	0.00833	0.042	2.08	36.00	75.00	Must be connected to another drainage facility
5	6	10	0.25	0.60	0.01000	0.050	2.50	30.00	75.00	
5	6	10	0.25	0.70	0.01167	0.058	2.92	25.71	75.00	
5	6	10	0.25	0.80	0.01333	0.067	3.33	22.50	75.00	
5	6	10	0.25	1.00	0.01667	0.083	4.17	18.00	75.00	
5	6	10	0.25	1.50	0.02500	0.125	6.25	12.00	75.00	
5	6	10	0.25	2.00	0.03333	0.167	8.33	9.00	75.00	
5	6	10	0.25	2.50	0.04167	0.208	10.42	7.20	75.00	
5	6	10	0.25	3.00	0.05000	0.250	12.50	6.00	75.00	

Underground Storage Volume and Percolation Rates for Green Infrastructure
5-foot wide x 10-foot long storage area.

Width (ft)	Depth of reservoir layer (ft)	Length (ft)	Design Porosity (% Voids)	Infiltration Rate		cf/hr/sf	cf/hr	hrs	LID Storage Volume for Standard Design (cf)	Note
				i						
				(in/hr)	(in/min)					
5	8	10	0.25	0.02	0.00033	0.002	0.08	1200.00	100.00	Must be connected to another drainage facility
5	8	10	0.25	0.04	0.00067	0.003	0.17	600.00	100.00	Must be connected to another drainage facility
5	8	10	0.25	0.06	0.00100	0.005	0.25	400.00	100.00	Must be connected to another drainage facility
5	8	10	0.25	0.08	0.00133	0.007	0.33	300.00	100.00	Must be connected to another drainage facility
5	8	10	0.25	0.10	0.00167	0.008	0.42	240.00	100.00	Must be connected to another drainage facility
5	8	10	0.25	0.15	0.00250	0.013	0.63	160.00	100.00	Must be connected to another drainage facility
5	8	10	0.25	0.20	0.00333	0.017	0.83	120.00	100.00	Must be connected to another drainage facility
5	8	10	0.25	0.25	0.00417	0.021	1.04	96.00	100.00	Must be connected to another drainage facility
5	8	10	0.25	0.30	0.00500	0.025	1.25	80.00	100.00	Must be connected to another drainage facility
5	8	10	0.25	0.40	0.00667	0.033	1.67	60.00	100.00	Must be connected to another drainage facility
5	8	10	0.25	0.50	0.00833	0.042	2.08	48.00	100.00	Must be connected to another drainage facility
5	8	10	0.25	0.60	0.01000	0.050	2.50	40.00	100.00	Must be connected to another drainage facility
5	8	10	0.25	0.70	0.01167	0.058	2.92	34.29	100.00	
5	8	10	0.25	0.80	0.01333	0.067	3.33	30.00	100.00	
5	8	10	0.25	1.00	0.01667	0.083	4.17	24.00	100.00	
5	8	10	0.25	1.50	0.02500	0.125	6.25	16.00	100.00	
5	8	10	0.25	2.00	0.03333	0.167	8.33	12.00	100.00	
5	8	10	0.25	2.50	0.04167	0.208	10.42	9.60	100.00	
5	8	10	0.25	3.00	0.05000	0.250	12.50	8.00	100.00	

Underground Storage Volume and Percolation Rates for Green Infrastructure
6-foot wide x 10-foot long storage area.

Width (ft)	Depth of reservoir layer (ft)	Length (ft)	Design Porosity (% Voids)	Infiltration Rate		cf/hr/sf	cf/hr	hrs	LID Storage Volume for Standard Design (cf)	Note
				i						
				(in/hr)	(in/min)					
6	2	10	0.25	0.02	0.00033	0.002	0.10	300.00	30.00	Must be connected to another drainage facility
6	2	10	0.25	0.04	0.00067	0.003	0.20	150.00	30.00	Must be connected to another drainage facility
6	2	10	0.25	0.06	0.00100	0.005	0.30	100.00	30.00	Must be connected to another drainage facility
6	2	10	0.25	0.08	0.00133	0.007	0.40	75.00	30.00	Must be connected to another drainage facility
6	2	10	0.25	0.10	0.00167	0.008	0.50	60.00	30.00	
6	2	10	0.25	0.15	0.00250	0.013	0.75	40.00	30.00	
6	2	10	0.25	0.20	0.00333	0.017	1.00	30.00	30.00	
6	2	10	0.25	0.25	0.00417	0.021	1.25	24.00	30.00	
6	2	10	0.25	0.30	0.00500	0.025	1.50	20.00	30.00	
6	2	10	0.25	0.40	0.00667	0.033	2.00	15.00	30.00	
6	2	10	0.25	0.50	0.00833	0.042	2.50	12.00	30.00	
6	2	10	0.25	0.60	0.01000	0.050	3.00	10.00	30.00	
6	2	10	0.25	0.70	0.01167	0.058	3.50	8.57	30.00	
6	2	10	0.25	0.80	0.01333	0.067	4.00	7.50	30.00	
6	2	10	0.25	1.00	0.01667	0.083	5.00	6.00	30.00	
6	2	10	0.25	1.50	0.02500	0.125	7.50	4.00	30.00	
6	2	10	0.25	2.00	0.03333	0.167	10.00	3.00	30.00	
6	2	10	0.25	2.50	0.04167	0.208	12.50	2.40	30.00	
6	2	10	0.25	3.00	0.05000	0.250	15.00	2.00	30.00	

**Underground Storage Volume and Percolation Rates for Green Infrastructure
6-foot wide x 10-foot long storage area.**

Width (ft)	Depth of reservoir layer (ft)	Length (ft)	Design Porosity (% Voids)	Infiltration Rate		cf/hr/sf	cf/hr	hrs	LID Storage Volume for Standard Design (cf)	Note
				i						
				(in/hr)	(in/min)					
6	4	10	0.25	0.02	0.00033	0.002	0.10	600.00	60.00	Must be connected to another drainage facility
6	4	10	0.25	0.04	0.00067	0.003	0.20	300.00	60.00	Must be connected to another drainage facility
6	4	10	0.25	0.06	0.00100	0.005	0.30	200.00	60.00	Must be connected to another drainage facility
6	4	10	0.25	0.08	0.00133	0.007	0.40	150.00	60.00	Must be connected to another drainage facility
6	4	10	0.25	0.10	0.00167	0.008	0.50	120.00	60.00	Must be connected to another drainage facility
6	4	10	0.25	0.15	0.00250	0.013	0.75	80.00	60.00	Must be connected to another drainage facility
6	4	10	0.25	0.20	0.00333	0.017	1.00	60.00	60.00	
6	4	10	0.25	0.25	0.00417	0.021	1.25	48.00	60.00	Must be connected to another drainage facility
6	4	10	0.25	0.30	0.00500	0.025	1.50	40.00	60.00	Must be connected to another drainage facility
6	4	10	0.25	0.40	0.00667	0.033	2.00	30.00	60.00	
6	4	10	0.25	0.50	0.00833	0.042	2.50	24.00	60.00	
6	4	10	0.25	0.60	0.01000	0.050	3.00	20.00	60.00	
6	4	10	0.25	0.70	0.01167	0.058	3.50	17.14	60.00	
6	4	10	0.25	0.80	0.01333	0.067	4.00	15.00	60.00	
6	4	10	0.25	1.00	0.01667	0.083	5.00	12.00	60.00	
6	4	10	0.25	1.50	0.02500	0.125	7.50	8.00	60.00	
6	4	10	0.25	2.00	0.03333	0.167	10.00	6.00	60.00	
6	4	10	0.25	2.50	0.04167	0.208	12.50	4.80	60.00	
6	4	10	0.25	3.00	0.05000	0.250	15.00	4.00	60.00	

Underground Storage Volume and Percolation Rates for Green Infrastructure
6-foot wide x 10-foot long storage area.

Width (ft)	Depth of reservoir layer (ft)	Length (ft)	Design Porosity (% Voids)	Infiltration Rate		cf/hr/sf	cf/hr	hrs	LID Storage Volume for Standard Design (cf)	Note
				i						
				(in/hr)	(in/min)					
6	6	10	0.25	0.02	0.00033	0.002	0.10	900.00	90.00	Must be connected to another drainage facility
6	6	10	0.25	0.04	0.00067	0.003	0.20	450.00	90.00	Must be connected to another drainage facility
6	6	10	0.25	0.06	0.00100	0.005	0.30	300.00	90.00	Must be connected to another drainage facility
6	6	10	0.25	0.08	0.00133	0.007	0.40	225.00	90.00	Must be connected to another drainage facility
6	6	10	0.25	0.10	0.00167	0.008	0.50	180.00	90.00	Must be connected to another drainage facility
6	6	10	0.25	0.15	0.00250	0.013	0.75	120.00	90.00	Must be connected to another drainage facility
6	6	10	0.25	0.20	0.00333	0.017	1.00	90.00	90.00	Must be connected to another drainage facility
6	6	10	0.25	0.25	0.00417	0.021	1.25	72.00	90.00	Must be connected to another drainage facility
6	6	10	0.25	0.30	0.00500	0.025	1.50	60.00	90.00	Must be connected to another drainage facility
6	6	10	0.25	0.40	0.00667	0.033	2.00	45.00	90.00	Must be connected to another drainage facility
6	6	10	0.25	0.50	0.00833	0.042	2.50	36.00	90.00	
6	6	10	0.25	0.60	0.01000	0.050	3.00	30.00	90.00	
6	6	10	0.25	0.70	0.01167	0.058	3.50	25.71	90.00	
6	6	10	0.25	0.80	0.01333	0.067	4.00	22.50	90.00	
6	6	10	0.25	1.00	0.01667	0.083	5.00	18.00	90.00	
6	6	10	0.25	1.50	0.02500	0.125	7.50	12.00	90.00	
6	6	10	0.25	2.00	0.03333	0.167	10.00	9.00	90.00	
6	6	10	0.25	2.50	0.04167	0.208	12.50	7.20	90.00	
6	6	10	0.25	3.00	0.05000	0.250	15.00	6.00	90.00	

**Underground Storage Volume and Percolation Rates for Green Infrastructure
6-foot wide x 10-foot long storage area.**

Width (ft)	Depth of reservoir layer (ft)	Length (ft)	Design Porosity (% Voids)	Infiltration Rate		cf/hr/sf	cf/hr	hrs	LID Storage Volume for Standard Design (cf)	Note
				i						
				(in/hr)	(in/min)					
6	8	10	0.25	0.02	0.00033	0.002	0.10	1200.00	120.00	Must be connected to another drainage facility
6	8	10	0.25	0.04	0.00067	0.003	0.20	600.00	120.00	Must be connected to another drainage facility
6	8	10	0.25	0.06	0.00100	0.005	0.30	400.00	120.00	Must be connected to another drainage facility
6	8	10	0.25	0.08	0.00133	0.007	0.40	300.00	120.00	Must be connected to another drainage facility
6	8	10	0.25	0.10	0.00167	0.008	0.50	240.00	120.00	Must be connected to another drainage facility
6	8	10	0.25	0.15	0.00250	0.013	0.75	160.00	120.00	Must be connected to another drainage facility
6	8	10	0.25	0.20	0.00333	0.017	1.00	120.00	120.00	Must be connected to another drainage facility
6	8	10	0.25	0.25	0.00417	0.021	1.25	96.00	120.00	Must be connected to another drainage facility
6	8	10	0.25	0.30	0.00500	0.025	1.50	80.00	120.00	Must be connected to another drainage facility
6	8	10	0.25	0.40	0.00667	0.033	2.00	60.00	120.00	Must be connected to another drainage facility
6	8	10	0.25	0.50	0.00833	0.042	2.50	48.00	120.00	Must be connected to another drainage facility
6	8	10	0.25	0.60	0.01000	0.050	3.00	40.00	120.00	Must be connected to another drainage facility
6	8	10	0.25	0.70	0.01167	0.058	3.50	34.29	120.00	
6	8	10	0.25	0.80	0.01333	0.067	4.00	30.00	120.00	
6	8	10	0.25	1.00	0.01667	0.083	5.00	24.00	120.00	
6	8	10	0.25	1.50	0.02500	0.125	7.50	16.00	120.00	
6	8	10	0.25	2.00	0.03333	0.167	10.00	12.00	120.00	
6	8	10	0.25	2.50	0.04167	0.208	12.50	9.60	120.00	
6	8	10	0.25	3.00	0.05000	0.250	15.00	8.00	120.00	

Underground Storage Volume and Percolation Rates for Green Infrastructure
8-foot wide x 10-foot long storage area.

Width (ft)	Depth of reservoir layer (ft)	Length (ft)	Design Porosity (% Voids)	Infiltration Rate		cf/hr/sf	cf/hr	hrs	LID Storage Volume for Standard Design (cf)	Note
				i						
				(in/hr)	(in/min)					
8	2	10	0.25	0.02	0.00033	0.002	0.13	300.00	40.00	Must be connected to another drainage facility
8	2	10	0.25	0.04	0.00067	0.003	0.27	150.00	40.00	Must be connected to another drainage facility
8	2	10	0.25	0.06	0.00100	0.005	0.40	100.00	40.00	Must be connected to another drainage facility
8	2	10	0.25	0.08	0.00133	0.007	0.53	75.00	40.00	Must be connected to another drainage facility
8	2	10	0.25	0.10	0.00167	0.008	0.67	60.00	40.00	Must be connected to another drainage facility
8	2	10	0.25	0.15	0.00250	0.013	1.00	40.00	40.00	Must be connected to another drainage facility
8	2	10	0.25	0.20	0.00333	0.017	1.33	30.00	40.00	
8	2	10	0.25	0.25	0.00417	0.021	1.67	24.00	40.00	
8	2	10	0.25	0.30	0.00500	0.025	2.00	20.00	40.00	
8	2	10	0.25	0.40	0.00667	0.033	2.67	15.00	40.00	
8	2	10	0.25	0.50	0.00833	0.042	3.33	12.00	40.00	
8	2	10	0.25	0.60	0.01000	0.050	4.00	10.00	40.00	
8	2	10	0.25	0.70	0.01167	0.058	4.67	8.57	40.00	
8	2	10	0.25	0.80	0.01333	0.067	5.33	7.50	40.00	
8	2	10	0.25	1.00	0.01667	0.083	6.67	6.00	40.00	
8	2	10	0.25	1.50	0.02500	0.125	10.00	4.00	40.00	
8	2	10	0.25	2.00	0.03333	0.167	13.33	3.00	40.00	
8	2	10	0.25	2.50	0.04167	0.208	16.67	2.40	40.00	
8	2	10	0.25	3.00	0.05000	0.250	20.00	2.00	40.00	

**Underground Storage Volume and Percolation Rates for Green Infrastructure
8-foot wide x 10-foot long storage area.**

Width (ft)	Depth of reservoir layer (ft)	Length (ft)	Design Porosity (% Voids)	Infiltration Rate		cf/hr/sf	cf/hr	hrs	LID Storage Volume for Standard Design (cf)	Note
				i						
				(in/hr)	(in/min)					
8	4	10	0.25	0.02	0.00033	0.002	0.13	600.00	80.00	Must be connected to another drainage facility
8	4	10	0.25	0.04	0.00067	0.003	0.27	300.00	80.00	Must be connected to another drainage facility
8	4	10	0.25	0.06	0.00100	0.005	0.40	200.00	80.00	Must be connected to another drainage facility
8	4	10	0.25	0.08	0.00133	0.007	0.53	150.00	80.00	Must be connected to another drainage facility
8	4	10	0.25	0.10	0.00167	0.008	0.67	120.00	80.00	Must be connected to another drainage facility
8	4	10	0.25	0.15	0.00250	0.013	1.00	80.00	80.00	Must be connected to another drainage facility
8	4	10	0.25	0.20	0.00333	0.017	1.33	60.00	80.00	Must be connected to another drainage facility
8	4	10	0.25	0.25	0.00417	0.021	1.67	48.00	80.00	Must be connected to another drainage facility
8	4	10	0.25	0.30	0.00500	0.025	2.00	40.00	80.00	Must be connected to another drainage facility
8	4	10	0.25	0.40	0.00667	0.033	2.67	30.00	80.00	
8	4	10	0.25	0.50	0.00833	0.042	3.33	24.00	80.00	
8	4	10	0.25	0.60	0.01000	0.050	4.00	20.00	80.00	
8	4	10	0.25	0.70	0.01167	0.058	4.67	17.14	80.00	
8	4	10	0.25	0.80	0.01333	0.067	5.33	15.00	80.00	
8	4	10	0.25	1.00	0.01667	0.083	6.67	12.00	80.00	
8	4	10	0.25	1.50	0.02500	0.125	10.00	8.00	80.00	
8	4	10	0.25	2.00	0.03333	0.167	13.33	6.00	80.00	
8	4	10	0.25	2.50	0.04167	0.208	16.67	4.80	80.00	
8	4	10	0.25	3.00	0.05000	0.250	20.00	4.00	80.00	

Underground Storage Volume and Percolation Rates for Green Infrastructure
8-foot wide x 10-foot long storage area.

Width (ft)	Depth of reservoir layer (ft)	Length (ft)	Design Porosity (% Voids)	Infiltration Rate		cf/hr/sf	cf/hr	hrs	LID Storage Volume for Standard Design (cf)	Note
				i						
				(in/hr)	(in/min)					
8	6	10	0.25	0.02	0.00033	0.002	0.13	900.00	120.00	Must be connected to another drainage facility
8	6	10	0.25	0.04	0.00067	0.003	0.27	450.00	120.00	Must be connected to another drainage facility
8	6	10	0.25	0.06	0.00100	0.005	0.40	300.00	120.00	Must be connected to another drainage facility
8	6	10	0.25	0.08	0.00133	0.007	0.53	225.00	120.00	Must be connected to another drainage facility
8	6	10	0.25	0.10	0.00167	0.008	0.67	180.00	120.00	Must be connected to another drainage facility
8	6	10	0.25	0.15	0.00250	0.013	1.00	120.00	120.00	Must be connected to another drainage facility
8	6	10	0.25	0.20	0.00333	0.017	1.33	90.00	120.00	Must be connected to another drainage facility
8	6	10	0.25	0.25	0.00417	0.021	1.67	72.00	120.00	Must be connected to another drainage facility
8	6	10	0.25	0.30	0.00500	0.025	2.00	60.00	120.00	Must be connected to another drainage facility
8	6	10	0.25	0.40	0.00667	0.033	2.67	45.00	120.00	Must be connected to another drainage facility
8	6	10	0.25	0.50	0.00833	0.042	3.33	36.00	120.00	
8	6	10	0.25	0.60	0.01000	0.050	4.00	30.00	120.00	
8	6	10	0.25	0.70	0.01167	0.058	4.67	25.71	120.00	
8	6	10	0.25	0.80	0.01333	0.067	5.33	22.50	120.00	
8	6	10	0.25	1.00	0.01667	0.083	6.67	18.00	120.00	
8	6	10	0.25	1.50	0.02500	0.125	10.00	12.00	120.00	
8	6	10	0.25	2.00	0.03333	0.167	13.33	9.00	120.00	
8	6	10	0.25	2.50	0.04167	0.208	16.67	7.20	120.00	
8	6	10	0.25	3.00	0.05000	0.250	20.00	6.00	120.00	

**Underground Storage Volume and Percolation Rates for Green Infrastructure
8-foot wide x 10-foot long storage area.**

Width (ft)	Depth of reservoir layer (ft)	Length (ft)	Design Porosity (% Voids)	Infiltration Rate		cf/hr/sf	cf/hr	hrs	LID Storage Volume for Standard Design (cf)	Note
				i						
				(in/hr)	(in/min)					
8	8	10	0.25	0.02	0.00033	0.002	0.13	1200.00	160.00	Must be connected to another drainage facility
8	8	10	0.25	0.04	0.00067	0.003	0.27	600.00	160.00	Must be connected to another drainage facility
8	8	10	0.25	0.06	0.00100	0.005	0.40	400.00	160.00	Must be connected to another drainage facility
8	8	10	0.25	0.08	0.00133	0.007	0.53	300.00	160.00	Must be connected to another drainage facility
8	8	10	0.25	0.10	0.00167	0.008	0.67	240.00	160.00	Must be connected to another drainage facility
8	8	10	0.25	0.15	0.00250	0.013	1.00	160.00	160.00	Must be connected to another drainage facility
8	8	10	0.25	0.20	0.00333	0.017	1.33	120.00	160.00	Must be connected to another drainage facility
8	8	10	0.25	0.25	0.00417	0.021	1.67	96.00	160.00	Must be connected to another drainage facility
8	8	10	0.25	0.30	0.00500	0.025	2.00	80.00	160.00	Must be connected to another drainage facility
8	8	10	0.25	0.40	0.00667	0.033	2.67	60.00	160.00	Must be connected to another drainage facility
8	8	10	0.25	0.50	0.00833	0.042	3.33	48.00	160.00	Must be connected to another drainage facility
8	8	10	0.25	0.60	0.01000	0.050	4.00	40.00	160.00	Must be connected to another drainage facility
8	8	10	0.25	0.70	0.01167	0.058	4.67	34.29	160.00	
8	8	10	0.25	0.80	0.01333	0.067	5.33	30.00	160.00	
8	8	10	0.25	1.00	0.01667	0.083	6.67	24.00	160.00	
8	8	10	0.25	1.50	0.02500	0.125	10.00	16.00	160.00	
8	8	10	0.25	2.00	0.03333	0.167	13.33	12.00	160.00	
8	8	10	0.25	2.50	0.04167	0.208	16.67	9.60	160.00	
8	8	10	0.25	3.00	0.05000	0.250	20.00	8.00	160.00	

Underground Storage Volume and Percolation Rates for Green Infrastructure
10-foot wide x 10-foot long storage area.

Width (ft)	Depth of reservoir layer (ft)	Length (ft)	Design Porosity (% Voids)	Infiltration Rate		cf/hr/sf	cf/hr	hrs	LID Storage Volume for Standard Design (cf)	Note
				i						
				(in/hr)	(in/min)					
10	2	10	0.25	0.02	0.00033	0.002	0.17	300.00	50.00	Must be connected to another drainage facility
10	2	10	0.25	0.04	0.00067	0.003	0.33	150.00	50.00	Must be connected to another drainage facility
10	2	10	0.25	0.06	0.00100	0.005	0.50	100.00	50.00	Must be connected to another drainage facility
10	2	10	0.25	0.08	0.00133	0.007	0.67	75.00	50.00	Must be connected to another drainage facility
10	2	10	0.25	0.10	0.00167	0.008	0.83	60.00	50.00	Must be connected to another drainage facility
10	2	10	0.25	0.15	0.00250	0.013	1.25	40.00	50.00	Must be connected to another drainage facility
10	2	10	0.25	0.20	0.00333	0.017	1.67	30.00	50.00	
10	2	10	0.25	0.25	0.00417	0.021	2.08	24.00	50.00	
10	2	10	0.25	0.30	0.00500	0.025	2.50	20.00	50.00	
10	2	10	0.25	0.40	0.00667	0.033	3.33	15.00	50.00	
10	2	10	0.25	0.50	0.00833	0.042	4.17	12.00	50.00	
10	2	10	0.25	0.60	0.01000	0.050	5.00	10.00	50.00	
10	2	10	0.25	0.70	0.01167	0.058	5.83	8.57	50.00	
10	2	10	0.25	0.80	0.01333	0.067	6.67	7.50	50.00	
10	2	10	0.25	1.00	0.01667	0.083	8.33	6.00	50.00	
10	2	10	0.25	1.50	0.02500	0.125	12.50	4.00	50.00	
10	2	10	0.25	2.00	0.03333	0.167	16.67	3.00	50.00	
10	2	10	0.25	2.50	0.04167	0.208	20.83	2.40	50.00	
10	2	10	0.25	3.00	0.05000	0.250	25.00	2.00	50.00	

Underground Storage Volume and Percolation Rates for Green Infrastructure
10-foot wide x 10-foot long storage area.

Width (ft)	Depth of reservoir layer (ft)	Length (ft)	Design Porosity (% Voids)	Infiltration Rate		cf/hr/sf	cf/hr	hrs	LID Storage Volume for Standard Design (cf)	Note
				i						
				(in/hr)	(in/min)					
10	4	10	0.25	0.02	0.00033	0.002	0.17	600.00	100.00	Must be connected to another drainage facility
10	4	10	0.25	0.04	0.00067	0.003	0.33	300.00	100.00	Must be connected to another drainage facility
10	4	10	0.25	0.06	0.00100	0.005	0.50	200.00	100.00	Must be connected to another drainage facility
10	4	10	0.25	0.08	0.00133	0.007	0.67	150.00	100.00	Must be connected to another drainage facility
10	4	10	0.25	0.10	0.00167	0.008	0.83	120.00	100.00	Must be connected to another drainage facility
10	4	10	0.25	0.15	0.00250	0.013	1.25	80.00	100.00	Must be connected to another drainage facility
10	4	10	0.25	0.20	0.00333	0.017	1.67	60.00	100.00	Must be connected to another drainage facility
10	4	10	0.25	0.25	0.00417	0.021	2.08	48.00	100.00	Must be connected to another drainage facility
10	4	10	0.25	0.30	0.00500	0.025	2.50	40.00	100.00	Must be connected to another drainage facility
10	4	10	0.25	0.40	0.00667	0.033	3.33	30.00	100.00	
10	4	10	0.25	0.50	0.00833	0.042	4.17	24.00	100.00	
10	4	10	0.25	0.60	0.01000	0.050	5.00	20.00	100.00	
10	4	10	0.25	0.70	0.01167	0.058	5.83	17.14	100.00	
10	4	10	0.25	0.80	0.01333	0.067	6.67	15.00	100.00	
10	4	10	0.25	1.00	0.01667	0.083	8.33	12.00	100.00	
10	4	10	0.25	1.50	0.02500	0.125	12.50	8.00	100.00	
10	4	10	0.25	2.00	0.03333	0.167	16.67	6.00	100.00	
10	4	10	0.25	2.50	0.04167	0.208	20.83	4.80	100.00	
10	4	10	0.25	3.00	0.05000	0.250	25.00	4.00	100.00	

Underground Storage Volume and Percolation Rates for Green Infrastructure
10-foot wide x 10-foot long storage area.

Width (ft)	Depth of reservoir layer (ft)	Length (ft)	Design Porosity (% Voids)	Infiltration Rate		cf/hr/sf	cf/hr	hrs	LID Storage Volume for Standard Design (cf)	Note
				i						
				(in/hr)	(in/min)					
10	6	10	0.25	0.02	0.00033	0.002	0.17	900.00	150.00	Must be connected to another drainage facility
10	6	10	0.25	0.04	0.00067	0.003	0.33	450.00	150.00	Must be connected to another drainage facility
10	6	10	0.25	0.06	0.00100	0.005	0.50	300.00	150.00	Must be connected to another drainage facility
10	6	10	0.25	0.08	0.00133	0.007	0.67	225.00	150.00	Must be connected to another drainage facility
10	6	10	0.25	0.10	0.00167	0.008	0.83	180.00	150.00	Must be connected to another drainage facility
10	6	10	0.25	0.15	0.00250	0.013	1.25	120.00	150.00	Must be connected to another drainage facility
10	6	10	0.25	0.20	0.00333	0.017	1.67	90.00	150.00	Must be connected to another drainage facility
10	6	10	0.25	0.25	0.00417	0.021	2.08	72.00	150.00	Must be connected to another drainage facility
10	6	10	0.25	0.30	0.00500	0.025	2.50	60.00	150.00	Must be connected to another drainage facility
10	6	10	0.25	0.40	0.00667	0.033	3.33	45.00	150.00	Must be connected to another drainage facility
10	6	10	0.25	0.50	0.00833	0.042	4.17	36.00	150.00	
10	6	10	0.25	0.60	0.01000	0.050	5.00	30.00	150.00	
10	6	10	0.25	0.70	0.01167	0.058	5.83	25.71	150.00	
10	6	10	0.25	0.80	0.01333	0.067	6.67	22.50	150.00	
10	6	10	0.25	1.00	0.01667	0.083	8.33	18.00	150.00	
10	6	10	0.25	1.50	0.02500	0.125	12.50	12.00	150.00	
10	6	10	0.25	2.00	0.03333	0.167	16.67	9.00	150.00	
10	6	10	0.25	2.50	0.04167	0.208	20.83	7.20	150.00	
10	6	10	0.25	3.00	0.05000	0.250	25.00	6.00	150.00	

**Underground Storage Volume and Percolation Rates for Green Infrastructure
10-foot wide x 10-foot long storage area**

Width (ft)	Depth of reservoir layer (ft)	Length (ft)	Design Porosity (% Voids)	Infiltration Rate		cf/hr/sf	cf/hr	hrs	LID Storage Volume for Standard Design (cf)	Note
				i						
				(in/hr)	(in/min)					
10	8	10	0.25	0.02	0.00033	0.002	0.17	1200.00	200.00	Must be connected to another drainage facility
10	8	10	0.25	0.04	0.00067	0.003	0.33	600.00	200.00	Must be connected to another drainage facility
10	8	10	0.25	0.06	0.00100	0.005	0.50	400.00	200.00	Must be connected to another drainage facility
10	8	10	0.25	0.08	0.00133	0.007	0.67	300.00	200.00	Must be connected to another drainage facility
10	8	10	0.25	0.10	0.00167	0.008	0.83	240.00	200.00	Must be connected to another drainage facility
10	8	10	0.25	0.15	0.00250	0.013	1.25	160.00	200.00	Must be connected to another drainage facility
10	8	10	0.25	0.20	0.00333	0.017	1.67	120.00	200.00	Must be connected to another drainage facility
10	8	10	0.25	0.25	0.00417	0.021	2.08	96.00	200.00	Must be connected to another drainage facility
10	8	10	0.25	0.30	0.00500	0.025	2.50	80.00	200.00	Must be connected to another drainage facility
10	8	10	0.25	0.40	0.00667	0.033	3.33	60.00	200.00	Must be connected to another drainage facility
10	8	10	0.25	0.50	0.00833	0.042	4.17	48.00	200.00	Must be connected to another drainage facility
10	8	10	0.25	0.60	0.01000	0.050	5.00	40.00	200.00	Must be connected to another drainage facility
10	8	10	0.25	0.70	0.01167	0.058	5.83	34.29	200.00	
10	8	10	0.25	0.80	0.01333	0.067	6.67	30.00	200.00	
10	8	10	0.25	1.00	0.01667	0.083	8.33	24.00	200.00	
10	8	10	0.25	1.50	0.02500	0.125	12.50	16.00	200.00	
10	8	10	0.25	2.00	0.03333	0.167	16.67	12.00	200.00	
10	8	10	0.25	2.50	0.04167	0.208	20.83	9.60	200.00	
10	8	10	0.25	3.00	0.05000	0.250	25.00	8.00	200.00	

Rainfall Gage Table

Gage No	Number of Rainfall Events	Number of Rainfalls Less Than 0.5 inches	Ratio
1000	12541	9555	0.76
1200	1585	1325	0.84
1300	804	674	0.84
1500	789	623	0.79
1600	1547	1206	0.78
1700	1630	1312	0.80
1800	1025	848	0.83
1900	874	741	0.85
2000	1893	1574	0.83
3000	346	294	0.85

APPENDIX C: ADDITIONAL PLANT LISTS

Arizona Municipal Water Users Association – Landscape Plants for the Arizona Desert

<http://www.amwua.org/plants/>

Arizona Department of Forestry and Fire Management

<https://dffm.az.gov/forestry-community-forestry/urban-community-forestry/tree-care>

Arizona Department Water Resources Low Water Use Drought Tolerate Plant List for the Phoenix Active Management Area

http://infoshare.azwater.gov/docushare/dsweb/Get/Document-10087/Phoenix_AMA_LWUPL_3MP.pdf

Maricopa County Air Quality Trees & Air Quality List

<http://cleanairmakemore.com/wp-content/uploads/2018/08/Trees-and-Air-Quality-in-Maricopa-County.pdf>